

HP Archive

This vintage Hewlett Packard document was
preserved and distributed by

[www. hparchive.com](http://www.hparchive.com)

Please visit us on the web !

On-line curator: Tony Gerbic

INSTRUCTION AND OPERATING MANUAL
FOR

MODEL 710B

POWER SUPPLY

526

Serial ~~295~~ and Above

HEWLETT-PACKARD COMPANY
395 PAGE MILL ROAD, PALO ALTO, CALIFORNIA, U.S.A.

CAUTION

VOLTAGES WHICH ARE DANGEROUS TO LIFE ARE PRESENT
AT THE TERMINALS AND WITHIN THIS INSTRUMENT.

CAUTION

IF THIS INSTRUMENT IS EQUIPPED WITH 6L6 METAL TUBES
A DANGEROUS VOLTAGE MAY BE PRESENT BETWEEN THE
6L6 METAL TUBE SHIELDS AND THE CHASSIS.

General Description

Model 710B Power Supply is an excellent source of direct current power for laboratory and production use. The voltage output is continuously variable between 100 and 360 volts and is practically independent of either line voltage and applied load for any setting. The noise and hum level is very low for any condition of operation.

An alternating current output of 6.3 volts, center tapped, which will supply a maximum of 5 amperes is included in the power supply for supplying the filaments of tubes.

This power supply may be used to power low level amplifier, constant frequency oscillators, and any other equipment requiring a power supply of high stability and low noise level.

Parts Substitutions

Difficulties in procuring some of the parts used in this instrument may cause the electrical or physical values to deviate from those shown in this instruction manual. These substitutions have been made so as not to impair the performance of this instrument. Whenever replacement of any of these parts is necessary, either the substitute value or the original value may be used.

INSTRUCTIONS

MODEL 710B

POWER SUPPLY

Specifications

Regulated Output Ratings:

Voltage: 100 to 360 volts DC.

Current: 0 to 75 MA.

Maximum Output Ratings:

Current: 100 MA.

Filament Supply: 6.3 volts AC C.T. at 5A.

Regulation:

Approximately 1% for operating conditions within the Regulated Output Ratings and for line voltage variations of 105 to 125 volts /210 to 250 volts.

Noise and Hum:

Total noise and hum is less than .005 volts for operating conditions within regulated Output Ratings.

Required Power Source:

Voltage: 105 to 125 volts/210 to 250 volts.

Frequency: 50 to 60 cps.

Wattage: 90 watts maximum.

Overall Dimensions:

8-3/4" high x 7-3/4" wide x 11-5/8" deep.

Weight:

15 pounds.

Operating Instructions

Inspection--

This instrument has been thoroughly tested and inspected before being shipped and is ready for use when received.

After the instrument is unpacked, it should be inspected for damage received in transit. If any shipping damage is found, follow the procedure outlined in the "Claim for Damage in Shipment" page at the back of this instruction book.

Controls and Terminals --

DC ON - This switch controls the direct current supplied to the DC binding posts and indicator lamp which is lighted while there is voltage on these binding posts.

AC ON - This switch controls the power supplied to the instrument from the power line.

VOLTAGE CONTROL - This variable resistor varies the direct current output voltage.

FUSE .25 AMP - The fuseholder, located on the control panel, contains a .25 ampere cartridge fuse. The fuse may be replaced by unscrewing the fuseholder cap and inserting a new fuse.

FUSE 1.6 AMP - The fuseholder, located on the control panel, contains a 1.6 ampere cartridge fuse. The fuse may be replaced by unscrewing the fuseholder cap and inserting a new fuse. Whenever the instrument is operated from a 230 V power line, an .8 ampere fuse should be used. Replacement fuses for this instrument must be of the "Slo-blo" type as specified in the Replaceable Parts List.

+DC-, GND - These three binding posts are the DC output terminals and the chassis ground terminal.

CT, 6.3V - These three binding posts are connected directly to the 6.3V secondary of the power transformer. The CT terminal is connected to the center tap of this secondary.

Power Cable - The power cable consists of three conductors. Two of these conductors carry power to the instrument while the third conductor (green wire) is connected to the instrument chassis. The third wire projects from the cable near the plug end of the cable and may be connected to a ground when it is desirable to have a grounded instrument chassis.

Operation --

CAUTION - AVOID ELECTRIC SHOCK BY TURNING THE DC SWITCH TO THE OFF POSITION BEFORE MAKING ANY CONNECTIONS.

Connect the output terminals of the Model 710B to the load and connect the power cable to a 105-125 volts supply. Turn the toggle switch to DC ON, AC ON, and allow the instrument to warm-up for about two minutes. Adjust the VOLTAGE CONTROL for the desired voltage.

The Model 710B may be operated with either terminal of the DC output grounded. Any one of the three 6.3 terminals may be ground.

The instrument may be operated with the DC output ungrounded. This usually results in a slightly higher hum level but this may be corrected by reversing the power cable plug or by connecting a .05 mf capacitor from either the +DC or -DC terminal to the GND terminal.

Maintenance

CAUTION - Voltages which are DANGEROUS TO LIFE are present within this instrument. Disconnect the instrument from the power line whenever the cover or bottom plate is removed.

Cover and Bottom Plate Removal--

Remove the cover by unscrewing the ten screws located along the top and rear edges of the cover. The bottom plate can be removed by unscrewing four screws, one in each corner of the plate.

Tube Replacement --

Any tube in this instrument may be replaced with a new tube having RMA standard characteristics, without impairing the operation of the instrument. Tubes with abnormal characteristics will usually cause poor regulation.

Voltage Control Adjustment --

If the VOLTAGE CONTROL shifts so that it does not give a voltage range of from 100 to 360 volts, adjustment of R23 and R24 will be necessary.

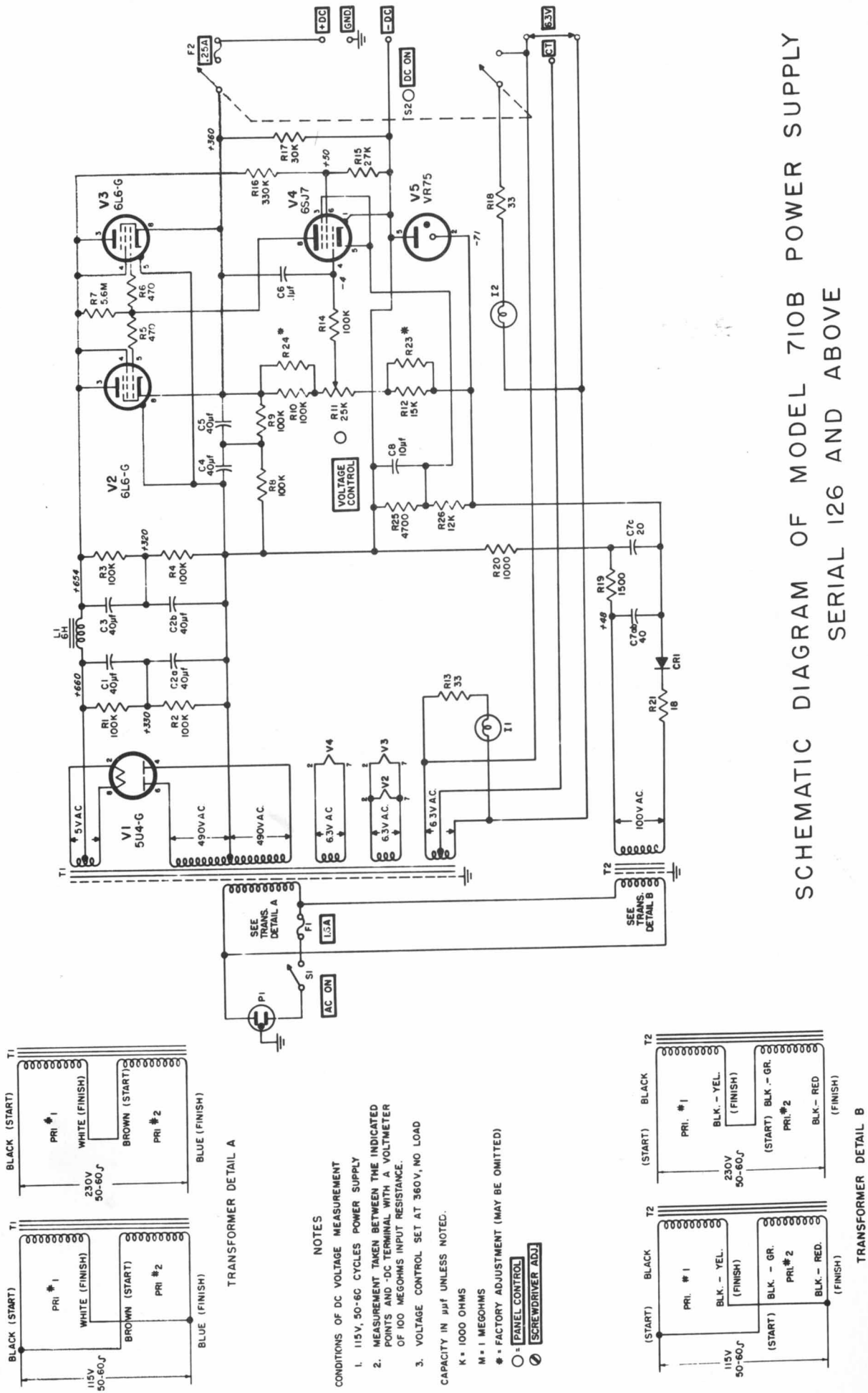

SCHEMATIC DIAGRAM OF MODEL 710B POWER SUPPLY
SERIAL 126 AND ABOVE

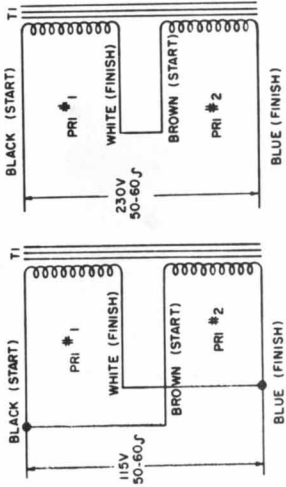

TRANSFORMER DETAIL A

NOTES

1. CONDITIONS OF DC VOLTAGE MEASUREMENT
2. MEASUREMENT TAKEN BETWEEN THE INDICATED POINTS AND -DC TERMINAL WITH A VOLTMETER OF 100 MEGOHMS INPUT RESISTANCE.
3. VOLTAGE CONTROL SET AT 360V, NO LOAD

CAPACITY IN μF UNLESS NOTED.

K = 1000 OHMS

M = 1 MEGOHMS

* = FACTORY ADJUSTMENT (MAY BE OMITTED)

○ = PANEL CONTROL

⊙ = SCREWDRIVER ADJ.

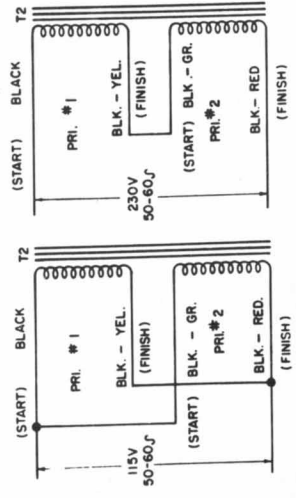

TRANSFORMER DETAIL B

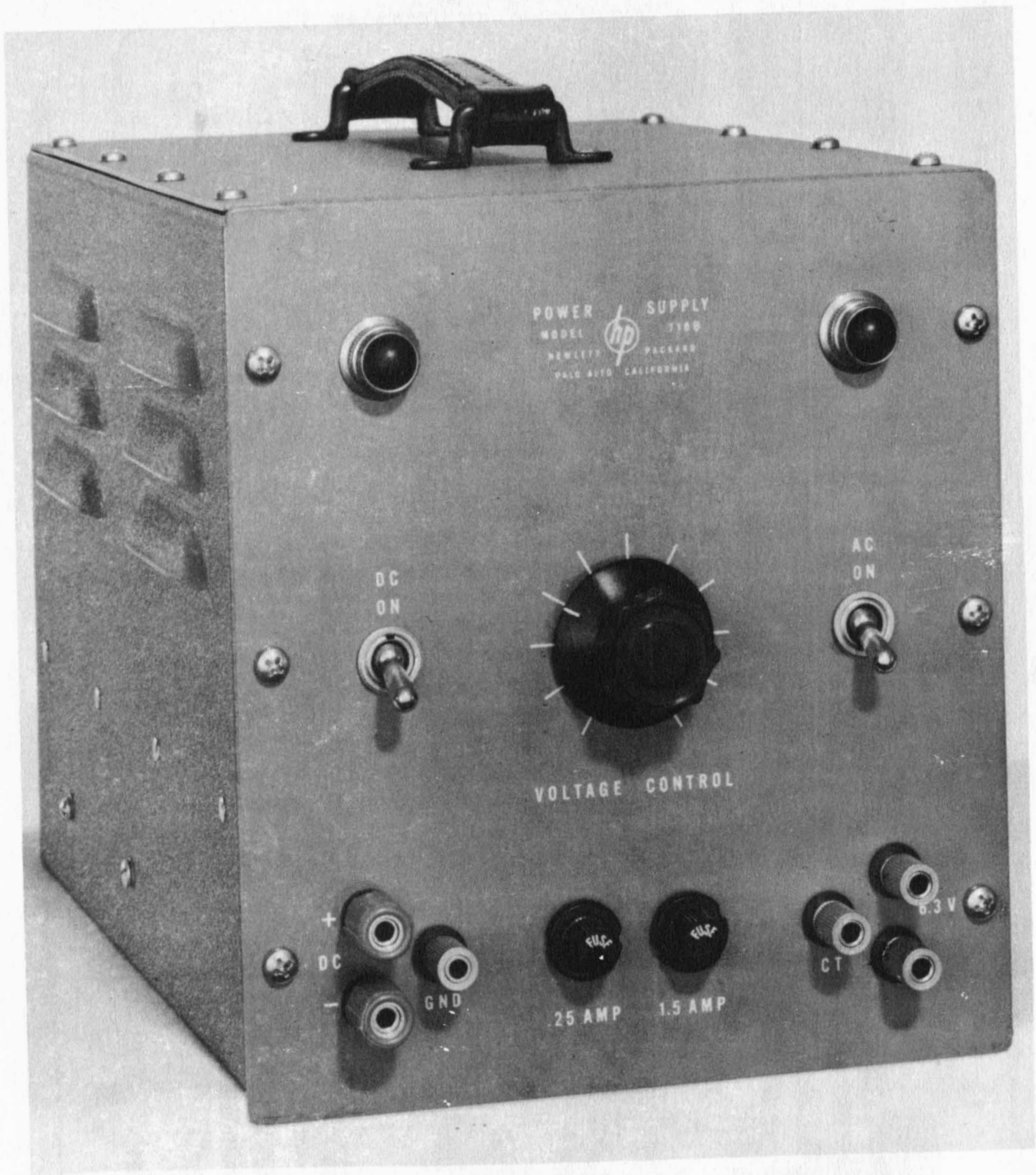

POWER SUPPLY
MODEL 7100
NEWLETT PACCAARD
PALO ALTO CALIFORNIA

DC
ON

AC
ON

VOLTAGE CONTROL

+
DC
-
GND

25 AMP 1.5 AMP

CT 6.3 V

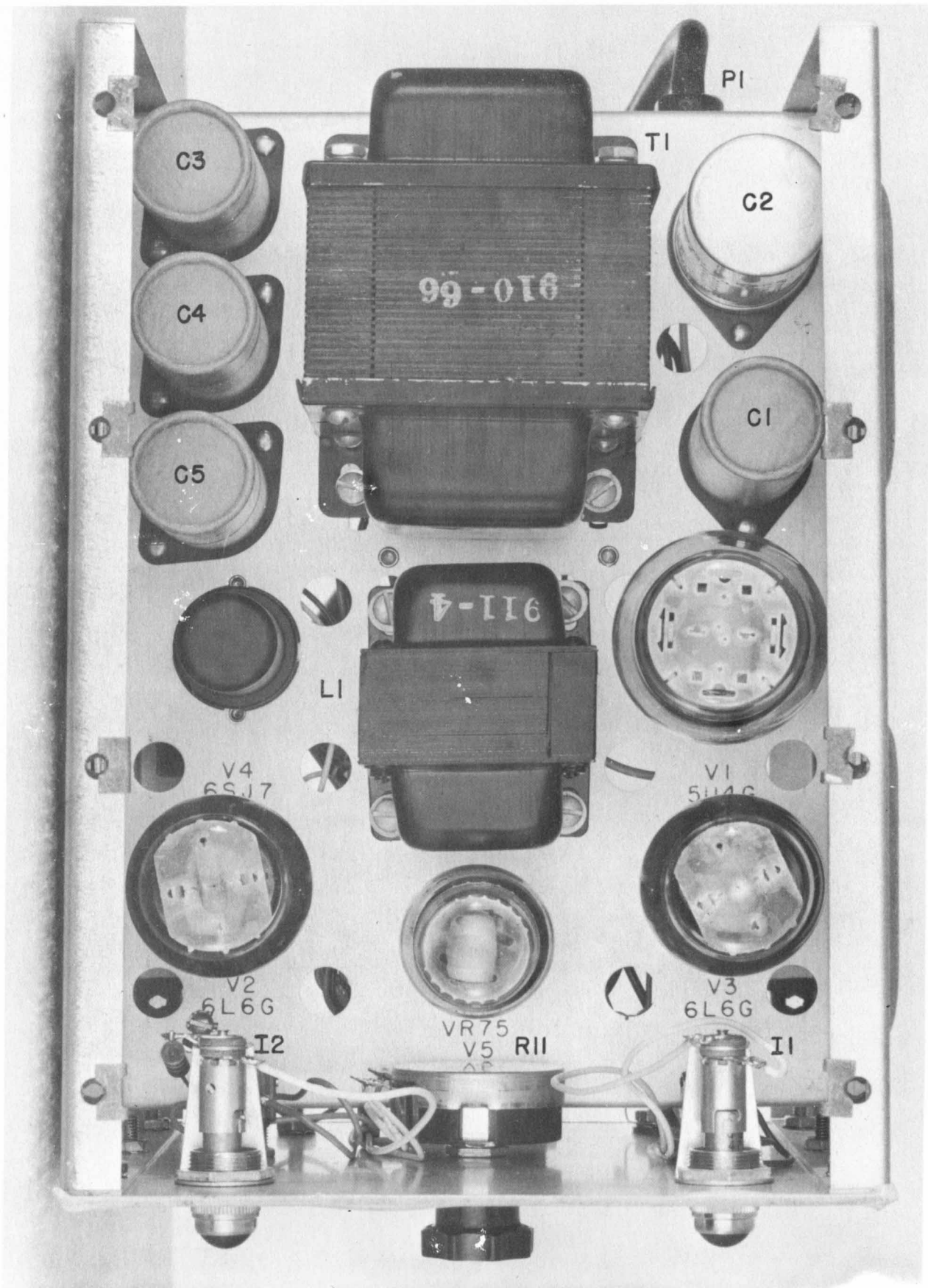

Model 710B Top View Cover Removed

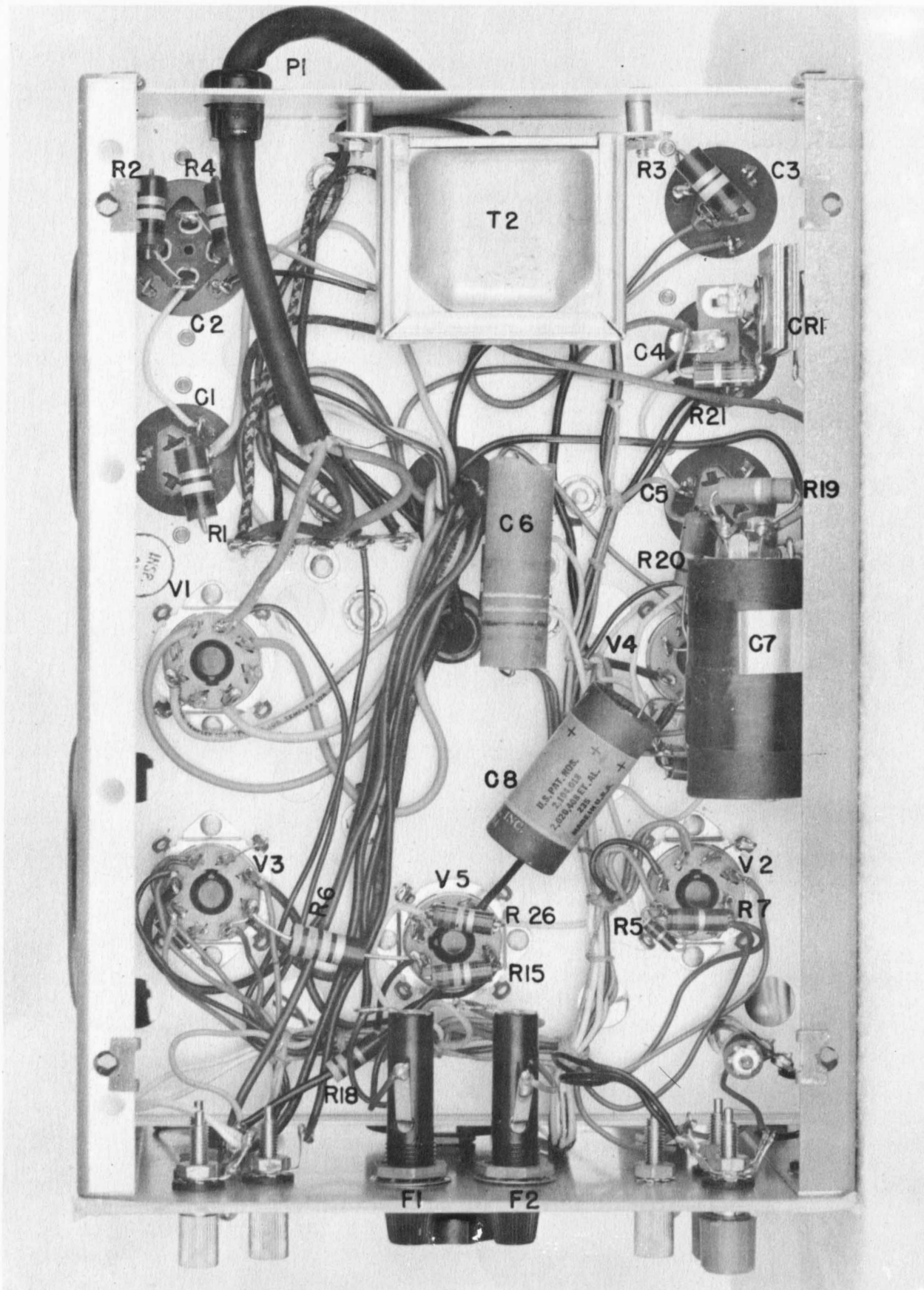

Model 710B Bottom View Bottom Plate Removed

TABLE OF REPLACEABLE PARTS

Circuit Ref.	Description	-hp- Stock No.	Mfr. * & Mfrs. Designation
C1, C3, C4, C5	Capacitor: fixed, electrolytic, 40 μ f, 450 vdcw	18-40	A AEF-1"x3"
C2 ab	Capacitor: fixed, electrolytic, 40 μ f, 450 vdcw	18-42	X FPQ-444
C6	Capacitor: fixed, paper, .1 μ f, 600 vdcw	16-1	A Type P688
C7 abc	Capacitor: fixed, electrolytic, 10, 10, 40 μ f, 150 vdcw	18-8	HP
C8	Capacitor: fixed, electrolytic, 10 μ f, 450 vdcw	18-10	X WB 72
R1, R2, R3, R4	Resistor: fixed, composition, 100,000 ohms, \pm 10%, 2W	25-100K	B HB 1041
R5, R6	Resistor: fixed, composition, 470 ohms, \pm 10%, 1/2W	23-470	B EB 4711
R7	Resistor: fixed, composition, 5.6 megohms, \pm 10%, 1W	24-5.6M	B GB 5651
R8, R9, R14	Resistor: fixed, composition, 100,000 ohms, \pm 10%, 1W	24-100K	B GB 1041
R10	Resistor: fixed, composition, 100,000 ohms, \pm 10%, 2W	25-100K	B HB 1041
R11	Resistor: variable, wirewound, 25,000 ohms, linear taper	210-10	I Type 58
R12	Resistor: fixed, composition, 15,000 ohms, \pm 10%, 1W	24-15K	B GB 1531
R13, R18	Resistor: fixed, composition, 33 ohms, \pm 10%, 1W	24-33	B GB 3301
R15	Resistor: fixed, composition, 27,000 ohms, \pm 10%, 1W	24-27K	B GB 2731
R16	Resistor: fixed, composition, 330,000 ohms, \pm 10%, 2W	25-330K	B HB 3341

*See "List of Manufacturers Code Letters For Replaceable Parts Table."

710B 9/19/52 Serial 126 to

TABLE OF REPLACEABLE PARTS

Circuit Ref.	Description	-hp- Stock No.	Mfr. * & Mfrs. Designation
R17, R22	Resistor: fixed, wirewound, 30,000 ohms, ±10%, 10 W	26-12	S Type 1-3/4E
R19	Resistor: fixed, composition, 1000 ohms, ±10%, 1 W	24-1000	B GB 1021
R20	Resistor: fixed, composition, 1500 ohms, ±10%, 1 W	24-1500	B GB 1521
R21	Resistor: fixed, composition, 18 ohms, ±10%, 1 W	24-18	B GB 1801
R23, R24	Resistor: factory adjustment		
R25	Resistor: fixed, composition, 4700 ohms, ±10%, 1 W	24-4700	B GB 4721
R26	Resistor: fixed, composition, 12,000 ohms, ±10%, 1 W	24-12K	B GB 1231
CR1	Rectifier:	212-60	M, #402D-3452A
F1	Fuse: 1.6A, withstands 200% overload for 25 sec. (115 volt operation)	211-15	E, MDL 1.6
F1	Fuse: .8A, withstands 200% overload for 25 sec. (230 volt operation)	--	E, MDL .8
F2	Fuse: .25A	211-6	T, #312.250
I1, I2	Lamp:	211-47	O, #47
	Knob: 1-1/2" diam.	37-11	HP
L1	Reactor: 6 H @ 125 MA; 240 ohms	911-47	HP
S1	Switch: toggle	310-11	D, 20994-HW
S2	Switch: toggle	310-21	D, 20902
T1	Transformer:	910-66	HP
T2	Transformer:	910-70	HP
	Binding Post:	312-3	HP
	Binding Post Cap Insulator:	M-58	HP
P1	Power Cable:	812-56	HP
	Fuseholder:	312-8	T, 342001

710B 10/7/53 Serial 295 to

*See "List of Manufacturers Code Letters For Replaceable Parts Table."

TABLE OF REPLACEABLE PARTS

Circuit Ref.	Description	-hp- Stock No.	Mfr. * & Mfrs. Designation
V1	Tube: 5U4G	212-5U4G	ZZ
V2	Tube: 6L6G	212-6L6G	ZZ
V3	Tube: 6L6G	212-6L6G	ZZ
V4	Tube: 6SJ7	212-6SJ7	ZZ
V5	Tube: VR75	212-VR75	ZZ

710B 9/19/52 Serial 126 to

*See "List of Manufacturers Code Letters For Replaceable Parts Table."

LIST OF MANUFACTURERS CODE LETTERS
FOR REPLACEABLE PARTS TABLE

<u>Code Letter</u>	<u>Manufacturer</u>
A	Aerovox Corp.
B	Allen-Bradley Co.
C	Amperite Co.
D	Arrow, Hart and Hegeman
E	Bussman Manufacturing Co.
F	Carborundum Co.
G	Centralab
H	Cinch Manufacturing Co.
I	Clarostat Manufacturing Co.
J	Cornell Dubilier Electric Co.
K	Electrical Reactance Co.
L	Erie Resistor Corp.
M	Federal Telephone and Radio Corp.
N	General Electric Co.
O	General Electric Supply Corp.
P	Girard-Hopkins
HP	Hewlett-Packard
Q	Industrial Products Co.
R	International Resistance Co.
S	Lectrohms, Inc.
T	Littelfuse, Inc.
U	Maguire Industries, Inc.
V	Micamold Radio Corp.
W	Oak Mfg. Co.
X	P. R. Mallory Co., Inc.
Y	Radio Corp. of America
Z	Sangamo Electric Co.
AA	Sarkes Tarzian
BB	Signal Indicator Co.
CC	Sprague Electric Co.
DD	Stackpole Carbon Co.
EE	Sylvania Electric Products, Inc.
FF	Western Electric Co.
GG	Wilkor Products, Inc.
HH	Amphenol
II	Dial Light Co. of America
JJ	Leecraft Manufacturing Co.
ZZ	Any tube having RMA standard characteristics

CLAIM FOR DAMAGE IN SHIPMENT

The instrument should be tested as soon as it is received. If it fails to operate properly, or is damaged in any way, a claim should be filed with the carrier. A full report of the damage should be obtained by the claim agent, and this report should be forwarded to us. We will then advise you of the disposition to be made of the equipment and arrange for repair or replacement. Include model number, type number and serial number when referring to this instrument for any reason.

WARRANTY

Hewlett-Packard Company warrants each instrument manufactured by them to be free from defects in material and workmanship. Our liability under this warranty is limited to servicing or adjusting any instrument returned to the factory for that purpose and to replace any defective parts thereof (except tubes, fuses and batteries). This warranty is effective for one year after delivery to the original purchaser when the instrument is returned, transportation charges prepaid by the original purchaser, and which upon our examination is disclosed to our satisfaction to be defective. If the fault has been caused by misuse or abnormal conditions of operation, repairs will be billed at cost. In this case, an estimate will be submitted before the work is started.

If any fault develops, the following steps should be taken:

1. Notify us, giving full details of the difficulty, and include the model number, type number and serial number. On receipt of this information, we will give you service instruction or shipping data.
2. On receipt of shipping instruction, forward the instrument prepaid, and repairs will be made at the factory. If requested, an estimate of the charges will be made before the work begins provided the instrument is not covered by the warranty.

SHIPPING

All shipments of Hewlett-Packard instruments should be made via Railway Express. The instruments should be packed in a wooden box and surrounded by two to three inches of excelsior or similar shock-absorbing material.

DO NOT HESITATE TO CALL ON US

HEWLETT-PACKARD COMPANY

Laboratory Instruments for Speed and Accuracy

395 PAGE MILL ROAD



PALO ALTO, CALIFORNIA