

HP Archive

This vintage Hewlett Packard document was preserved
and distributed by

[www. hparchive.com](http://www.hparchive.com)

Please visit us on the web.

For free distribution only!

Thanks to on-line curator: Bernhard Voss for supplying
and scanning this vintage document.

SIGNAL ANALYZER

5480A

**THIS MANUAL COVERS A
SPECIAL MODIFICATION
OF THE INSTRUMENT.
SEE INSIDE COVER**

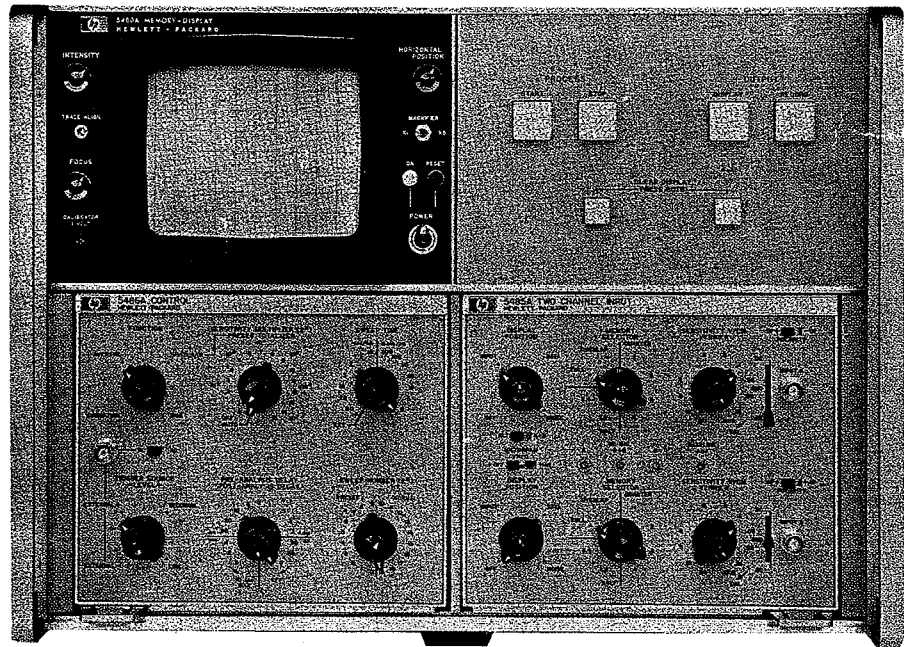

HEWLETT  PACKARD



MANUAL CHANGES

MODEL 5480A
 SIGNAL ANALYZER
 All Serials
 Manual Printed: NOV 1968

MAKE ALL CORRECTIONS IN THIS MANUAL ACCORDING TO ERRATA BELOW, THEN CHECK THE FOLLOWING TABLE FOR YOUR INSTRUMENT SERIAL PREFIX (3 DIGITS) OR SERIAL NUMBER (8 DIGITS) AND MAKE ANY LISTED CHANGE(S) IN THE MANUAL.

► NEW ITEM.

SERIAL PREFIX OR NUMBER	MAKE MANUAL CHANGES	SERIAL PREFIX OR NUMBER	MAKE MANUAL CHANGES

ADDENDA

The following information describes:

- I) The 5487A Four Channel Input Plug-in
- II) Option 01 (Variance Option), available for either 5485A or 5487A Input Plug-ins.

I. 5487A FOUR CHANNEL INPUT PLUG-IN.

1-1. INTRODUCTION.

1-2. The Hewlett-Packard Model 5487A Four Channel Input Plug-in enables the HP 5480A Signal Analyzer System to process and display up to four channels of information instead of only two, as is the case with the 5485A Two Channel Input Plug-in. In most respects, operation and nomenclature of this plug-in is the same as that for the 5485A described in the 5480A Operating Manual. Table 1 of this addendum lists specifications that are different from those listed in Table 1-1 of the 5480A Operating Manual when using the 5487A Plug-in.

1-3. OPERATION.

1-4. The following control differences between the 5487A and 5485A Plug-Ins should be noted:

a. MEMORY in 5487A selects portion of memory to be used for storage, display, or processing. Memory is divided into four quarters; MEMORY switch controls which plug-in channel is connected to which memory quarter. Table 2 of this addendum lists memory section-vs-plug-in channel allocations. FULL memory provides 1000-point resolution for any one channel; HALF memory provides 500-point resolution for any one channel; QUARTER memory provides 250-point resolution for any one channel.

b. DISPLAY in 5487A selects CRT display for all channels turned on (see Table 2 of this addendum). INPUT displays sampled input signals. DATA displays averaged signal, MCS, or histogram. NOISE displays difference between INPUT and averaged signal (DATA).

c. ON/OFF switches, plus MEMORY switch and some internal logic determine which channels will be processed or displayed. See Table 2 of this addendum for details. At least one channel must be turned on or there will be no processing or display.

1-5. To operate in any function (AVERAGE, SUMMATION, HISTOGRAM, or MCS), the instructions given for the Signal Analyzer System using the 5485A can be used with only slight changes required by the 5487A.

1-6. MAINTENANCE.

1-7. Maintenance is the same as that for the System using the 5485A. There are only two front-panel adjustments. BASELINE is made as described in the manual, DC BALANCE is made as described for any one channel of the 5485A (adjust for minimal offset).

May 27, 1969

ADDENDA
(Cont'd)

Table 1. Specifications (5480A Signal Analyzer System with 5487A Input Plug-in).

This table lists only those specifications for the 5480A Signal Analyzer System that are different when the 5485A Two Channel Input Plug-In is replaced with the 5487A Four Channel Input Plug-In. Specifications are listed in the order in which they are listed in Table 1-3 of the 5480A Operating Manual.

AVERAGING:

1. CALIBRATED AVERAGING MODE:

Input Characteristics (for 5487A Four Channel Input Plug-in):

Bandwidth: dc (2 Hz ac coupled) to 25 Hz.

Sensitivity: 50 mV/cm to 20 V/cm in 1, 2, 5 sequence, 3% accuracy.

Polarity Inversion: not available.

A+B: not available.

ALT: not available

Overlap Display: not available.

Display: For all channels that are on, operator may select CRT display of waveform as it is averaged, noise as it is removed from signal, or input signal after sampling.

Input Priorities: Channel A takes precedence over B, B takes precedence over C, C takes precedence over D.

Input Sampling Sequence: ABCDADCDA... .

Variance: Variance output can be ordered as 5487A Option 01. Variance option provides a square of the noise signal as an output.

Table 2. MEMORY SECTION VS PLUG-IN CHANNEL

MEMORY switch selects whether any one Plug-in channel will be connected to one (QUARTER), two (HALF), or four (FULL) quarters of memory.

FULL

All four memory quarters are connected to the highest priority channel that is turned "ON". Channel A has highest priority, followed, in order, by B, C, and D.

FULL MEMORY

connected to this channel when
channel is "ON".....

Unless

A
B
C
D

Channel A is ON
Channel A or B is ON
Channel A, B, or C is ON

HALF

Memory quarters are connected to Plug-In Channels as shown in chart below.

NOTES:

1. Numbers indicate identification numbers for the two memory quarters connected to a channel when that channel is ON.
2. ON/OFF indicates that all memory quarters are taken by higher-priority channels, and it makes no difference whether this channel is ON or OFF.
3. OFF indicates that this channel must be OFF to have this condition.

A	B	C	D
1, 2	OFF	OFF	OFF
OFF	3, 4	OFF	OFF
OFF	OFF	1, 2	OFF
OFF	OFF	OFF	3, 4
*1, 2	3, 4	ON/OFF	ON/OFF
1, 2	OFF	3, 4	ON/OFF
1, 2	OFF	OFF	3, 4
OFF	3, 4	1, 2	ON/OFF
OFF	3, 4	OFF	1, 2
OFF	OFF	1, 2	3, 4

*Recommended usage for two-channel operation.

ADDENDA
(Cont'd)

Table 2. MEMORY SECTION VS PLUG-IN CHANNEL (CONT'D)

QUARTER

Each memory quarter is connected to a specified Plug-in channel when that channel is ON. There is no change in quarter allocation when a channel is OFF.

- Channel A always gets quarter 1
- Channel B always gets quarter 2
- Channel C always gets quarter 3
- Channel D always gets quarter 4

II. OPTION 01 (VARIANCE OPTION).

2-1. DESCRIPTION.

This Option, available for both the 5485A and the 5487A Input Plug-Ins, enables use of the 5480A VARIANCE OUTPUT signal to check validity of the averaged signal. The Option may be ordered installed and tested at the factory, or it may be installed in the field. Field installation consists of replacing the Switching Logic B Assembly (05485-60010) with Switching Logic B Assembly (05485-60020); no wiring changes are required.

As the input waveform is processed, its average pattern is stored in the Signal Analyzer's memory. The Variance Option compares the input signal against this pattern, and its trace represents differences between the two. The variance trace can be used to identify points in the averaged waveform where there is additional activity other than that added simply by random noise. If the variance trace is a straight line, then the averaged waveform is the result of a single repetitive input which was time-locked to the synchronizing pulse (except for the special case where the absolute deviation of the spurious input from the average is the same at all points on the waveform).

If the leading or trailing edge of a pulse or square wave is jittering (or appears to be jittering due to a jittering trigger signal), the variance trace will not be a straight line (thus indicating that there was something in the signal besides noise and data). If the input signal waveform changes, the variance will not be a straight line, but will have a shape of its own, reflecting the signal change. The variance trace is also useful for detecting when a signal is not present during the entire analysis interval, by showing the difference between the stored averaged signal and the missing input signal. All that would happen to the averaged signal trace is that its amplitude would shrink slightly (depending on number of sweeps that had been averaged).

2-2. OPERATION.

To operate the variance option, connect 5480A rear-panel VARIANCE OUTPUT connector through a BNC-to-BNC cable to the 5485A or 5487A front-panel connector for any unused channel; use this channel to display the variance output; set DISPLAY for this channel to DATA; set MEMORY SELECTOR to any unused QUARTER or HALF. Each point in the variance output corresponds to the point immediately preceding it in the averaged signal waveform.

OPERATING AND SERVICE MANUAL

MODIFICATIONS

SPECIFICATION E07-5480A

SIGNAL ANALYZER

Specification E07-5480A consists of a Specification H07-5480A Signal Analyzer with a Specification H07-5485A Two Channel Input plug-in and a Specification H07-5486A Control plug-in.

Specification H07-5485A Two Channel Input plug-in is modified to allow external selection of input polarity with a switch added on the rear of the E07-5480A.

Specification H07-5486A Control plug-in is modified to provide a special mode of operation permitting the record of the number of sweeps performed to be erased when the DISPLAY indicator lights. A SPECIAL-NORMAL switch added on the rear of the E07-5480A provides selection between this special mode and standard instrument operation.

OPERATION

The purpose of this modification is to permit the analyzer to reduce noise that is synchronous with the trigger signal. After summing for 2^N sweeps (as determined by SWEEP NUMBER (2^N) switch) the signal may be cut off - leaving the input lead attached. Input polarity is then reversed (by switching at added BNC) and START button is depressed, initiating summation over an additional 2^N sweeps. Because of reversed input polarity, noise synchronous with the trigger signal will be subtracted from the stored data.

SCALING

1. SUMMATION MODE/AUTO SCALING: When DISPLAY indicator lights, CRT display is scaled as if 2^0 sweeps were summed. When START button is depressed, scaling

SCALING (Continued)

resumes as if memory were reset to zero. Actual memory data is unchanged.

2. **SUMMATION MODE (NOT AUTO SCALING):** CRT display is scaled according to SENSITIVITY MULTIPLIER (2^N) switch setting. Actual memory data is unchanged.
3. **AVERAGE MODE:** Scaling is unaffected. However, each time START button is depressed the averaging process begins again. On the first sweep the old data is replaced by the new input, as if the CLEAR DISPLAY buttons had been pressed.

In all other respects this instrument is electrically identical to the standard instrument. Therefore, information in the Operating and Service Manual for the standard instrument also applies to this special instrument.

Encl: 5480A
5485A, H07-5485A
5486A, H07-5486A

bpl/30469

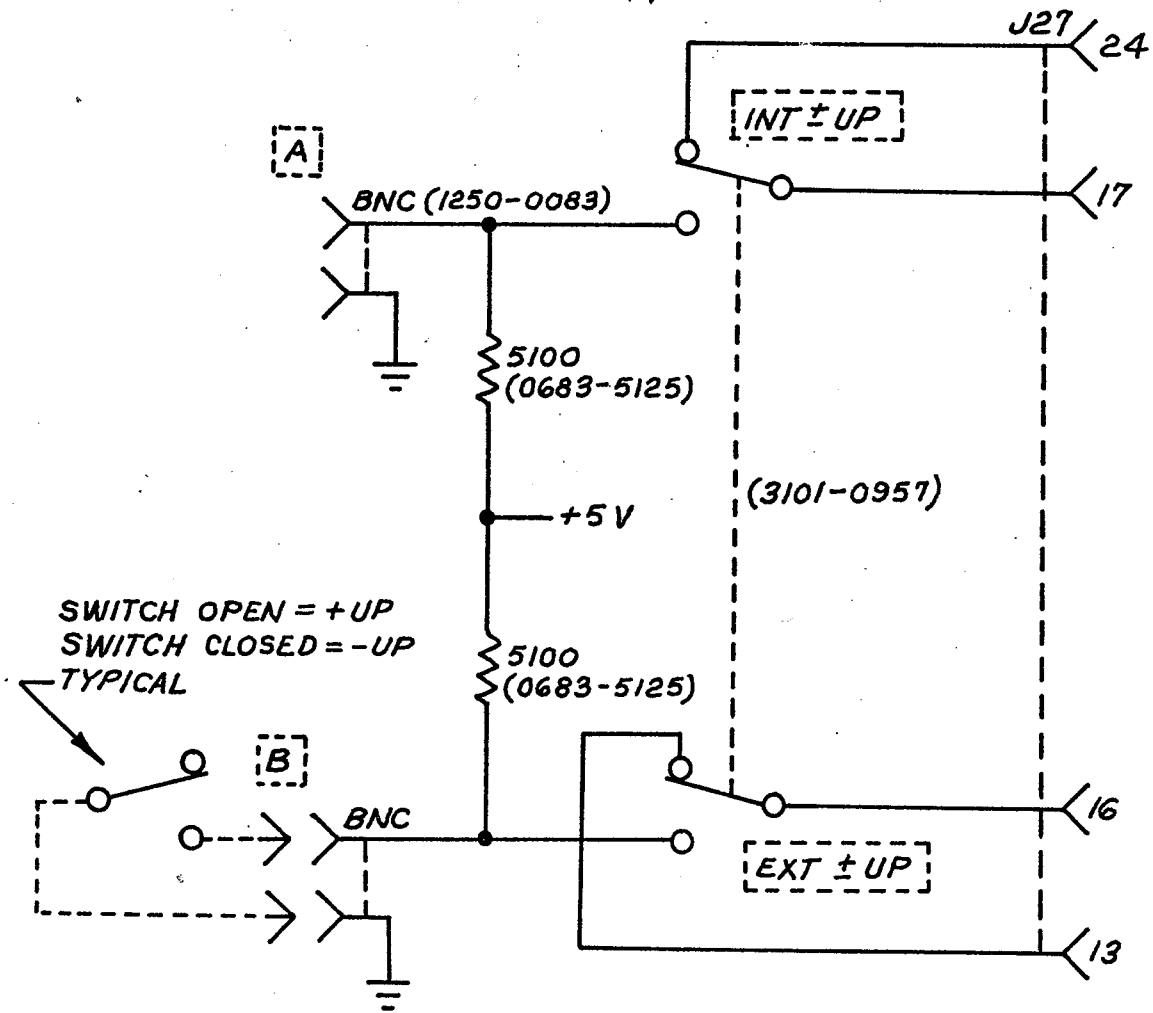

ADDED REAR-PANEL SWITCH
AND BNC CONNECTORS

00000-8-21

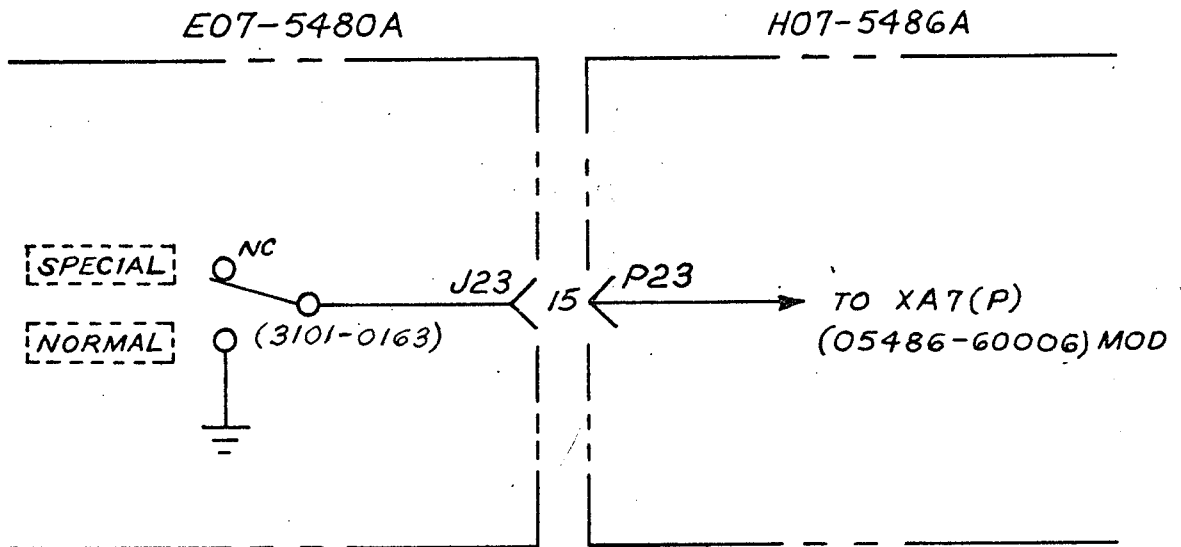

SPECIAL - NORMAL SWITCH WIRING

12-B-00000

ADDED INT ± UP - EXT ± UP
SWITCH and A and B CONNECTORS

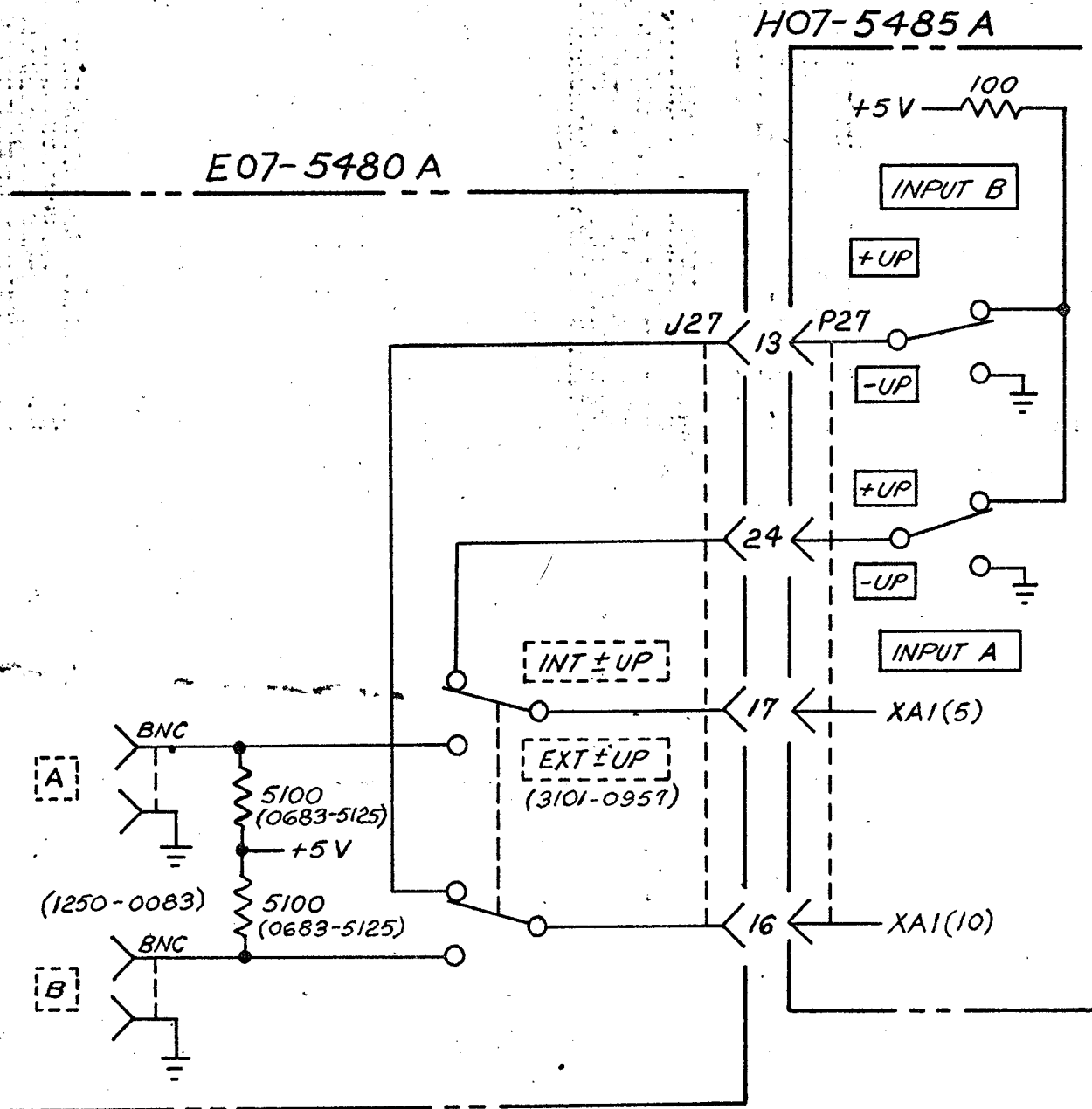

12-B-00000

OPERATING AND SERVICE MANUAL

MODIFICATIONS

SPECIFICATION H07-5485A

TWO CHANNEL INPUT PLUG-IN

Specification H07-5485A is a standard Model 5485A Two Channel input plug-in, electrically modified to provide external selection of input polarity \pm UP.

A switch, INT \pm UP and EXT \pm UP, and two BNC connectors, A and B, are added at the rear of the Model 5480A mainframe. Wiring of switch and connectors is shown in attached schematic diagram. When the switch is in INT \pm UP, the H07-5485A front-panel \pm UP POLARITY switches for INPUT A and INPUT B operate as in the standard instrument. When added switch is in EXT \pm UP, with no contact closure at BNC's the instrument will operate in the + UP mode. Contact closure across the BNC's will cause instrument to operate in - UP mode. External polarity switching may also be done by voltage level shifting from an IC package. Level requirements at rear-panel BNC's A and B are:

- a. For the + UP mode: $> +2.4V$ (5 V maximum),
or open circuit.
- b. For the - UP mode: $< +0.8V$ (zero V minimum),
or short circuit across BNC.

In all other respects this instrument is electrically identical to the standard instrument. Therefore, information in the Operating and Service Manual for the standard instrument also applies to this special instrument.

Encl: 5485A

bpl/30269

ADDED INT ± UP - EXT ± UP
SWITCH and A and B CONNECTORS

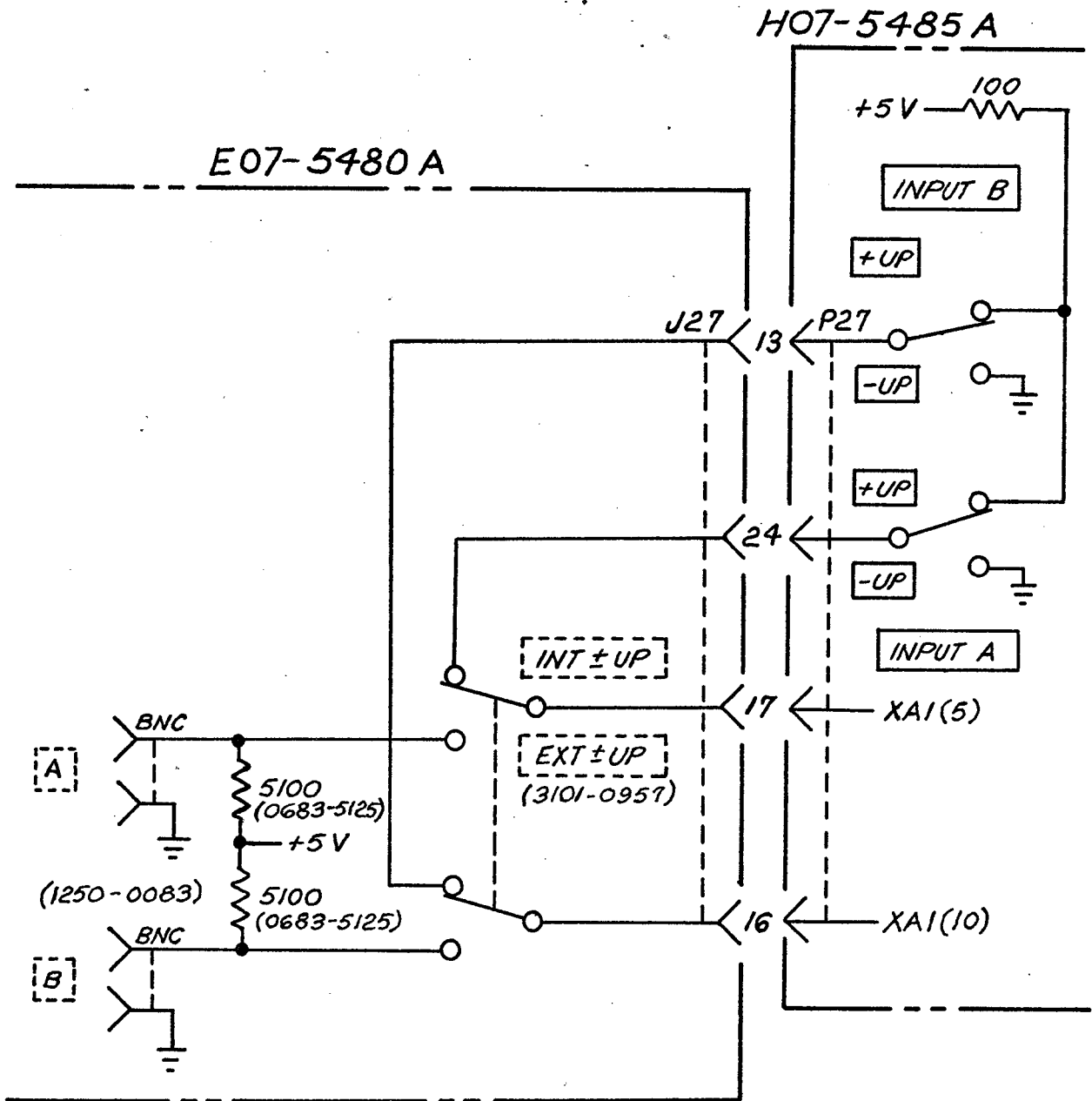

12-B-00000





OPERATING AND SERVICE MANUAL

MODIFICATIONS

SPECIFICATION H07-5486A

CONTROL PLUG-IN

Specification H07-5486A is a standard  Model 5486A Control Plug-in electrically modified so that when DISPLAY indicator lights the record of the number of sweeps performed is erased.

Logic A assembly A7,  Part No. 05486-60006, is replaced with circuit board 05486-60006 (MOD). The modification consists of adding IC50 to the standard circuit board. Wiring of modified circuit board is shown in attached schematic diagram. A connection is brought out from IC50 (4) to an added switch marked SPECIAL - NORMAL on the rear of the main frame of the E07-5480A. When switch is in SPECIAL sweep numbers are erased when DISPLAY indicator lights. With switch in NORMAL operation of instrument is standard.

In all other respects this instrument is electrically identical to the standard instrument. Therefore, information in the Operating and Service Manual for the standard instrument also applies to this special instrument.

Encl: 5486A

bpl/30469

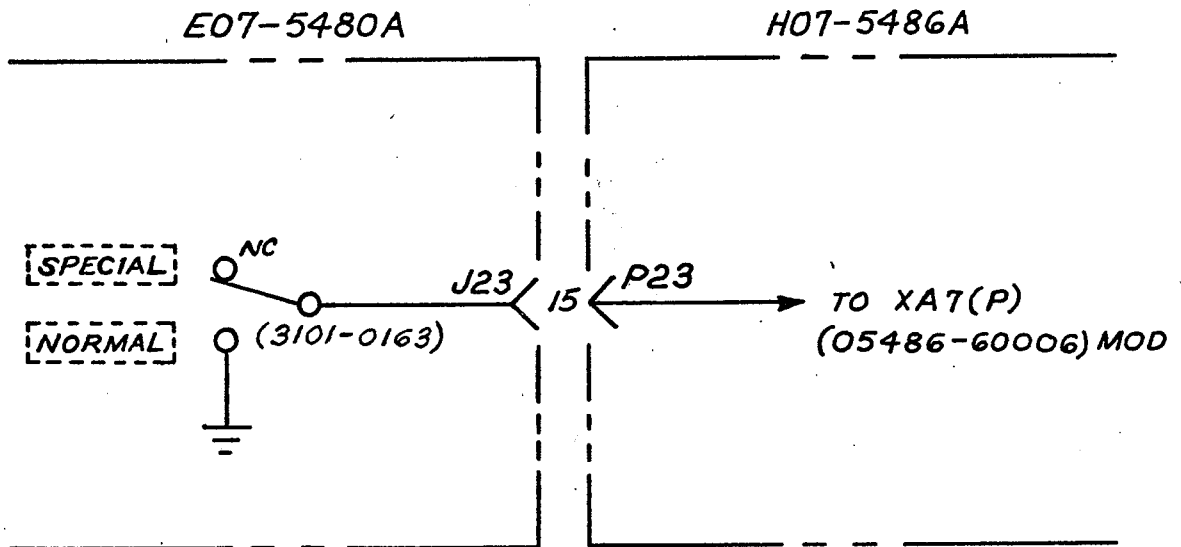

SPECIAL - NORMAL SWITCH WIRING

12-B-00000

A7 LOGIC A ASSEMBLY (05486-60006) (MOD)

NOTES

1. REFERENCE DESIGNATIONS WITHIN THIS ASSEMBLY ARE ABBREVIATED. ADD ASSEMBLY NUMBER TO ABBREVIATION FOR COMPLETE DESCRIPTION.
2. UNLESS OTHERWISE INDICATED: CAPACITANCE IN PICOFARADS;

REFERENCE DESIGNATIONS

A7
C1,2
IC2-14,
16-20,50
R1

COMPONENT LOCATOR

16	17	18	19	20
11	12	13	14	15
6	7	8	9	10
1	2	3	4	5

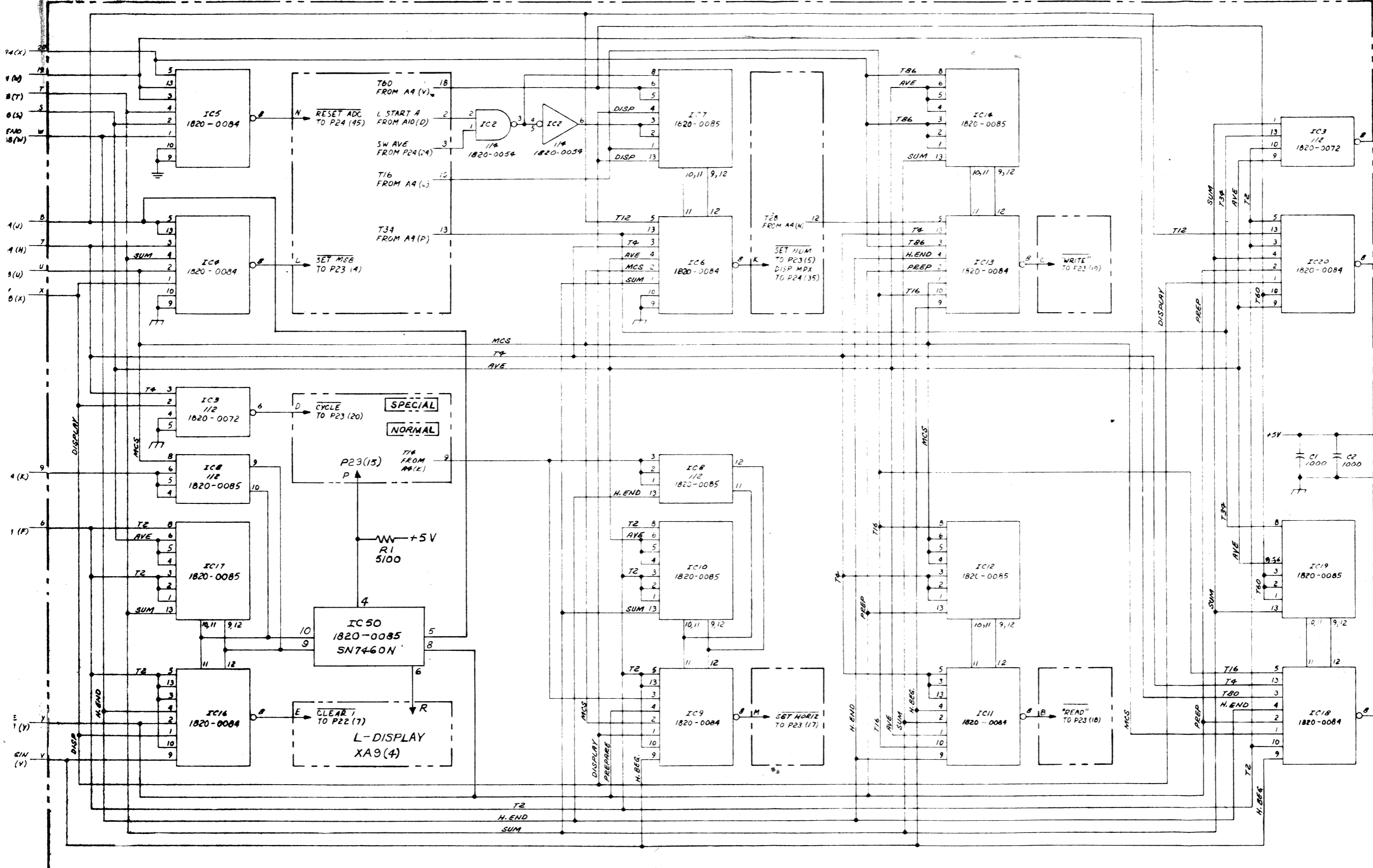

COPYRIGHT 1969 BY HEWLETT-PACKARD COMPANY 05486-6

SPECIFICATION H07-5486A LOGIC ASSY A7 (05486-60006) MOD

CERTIFICATION

The Hewlett-Packard Company certifies that this instrument was thoroughly tested and inspected and found to meet its published specifications when it was shipped from the factory. The Hewlett-Packard Company further certifies that its calibration measurements are traceable to the U.S. National Bureau of Standards to the extent allowed by the Bureau's calibration facility.

WARRANTY AND ASSISTANCE

All Hewlett-Packard products are warranted against defects in materials and workmanship. This warranty applies for one year from the date of delivery, or, in the case of certain major components listed in the operating manual, for the specified period. We will repair or replace products which prove to be defective during the warranty period provided they are returned to Hewlett-Packard. No other warranty is expressed or implied. We are not liable for consequential damages.

Service contracts or customer assistance agreements are available for Hewlett-Packard products that require maintenance and repair on-site.

For any assistance, contact your nearest Hewlett-Packard Sales and Service Office. Addresses are provided at the back of this manual.

SIGNAL ANALYZER

5480A

WITH 5485A and 5486A PLUG-INS

ALL SERIALS

This manual applies directly to all standard Hewlett-Packard Model 5480A Signal Analyzer systems using the Model 5485A Two Channel Input and Model 5486A Control plug-ins. See INSTRUMENT IDENTIFICATION, Paragraph 1-5.

SPECIAL INSTRUMENTS

The information required to relate this manual to special modifications is supplied on special insert sheets. If this information is missing, contact any HP Sales and Service office, giving full specification number, instrument name, and serial number.

Copyright HEWLETT-PACKARD COMPANY 1968
1501 PAGE MILL ROAD, PALO ALTO, CALIFORNIA, U.S.A.

02810-1

Printed: NOV 1968

HEWLETT  PACKARD

MANUAL CONTENT AND ORGANIZATION

This is a system operating manual only. Service information is contained in a separate set of manuals. Operating and service information is divided among the manuals as follows:

OPERATING MANUAL:

- General system information
- Packaging information
- System installation information
- Incoming inspection check
- Operating information

SERVICE MANUAL - VOLUME I:

- System block diagrams, includes principles of operation
- Adjustment procedures
- Troubleshooting procedures
- Adjustment and test point locations and waveforms

SERVICE MANUAL - VOLUME II AND HIGHER:

Each of these manuals is for one instrument in the Signal Analyzer system, and contains the following information:

- General information about that instrument
- Wiring and schematic drawings and/or lists
- Component locators for assemblies
- Assembly function descriptions
- Parts lists

MANUAL AND MANUAL CHANGES (ORDERING INFORMATION)

This manual provides operating information for all Hewlett-Packard Model 5480A Signal Analyzer systems including Model 5485A Two Channel Input and Model 5486A Control plug-ins. Manual changes required for special instruments will be detailed in special change sheets included with manuals for those systems. If information is missing, it may be obtained by contacting nearest Hewlett-Packard Sales and Service office listed at back of this manual. When requesting information or additional manuals for your system, be sure to include complete Model or Specification number, instrument name, and serial number. (For serial number information, see Paragraph 1-5.)

TABLE OF CONTENTS

Section	Page
I GENERAL INFORMATION	1-1
1-1. Introduction	1-1
1-5. Instrument Identification	1-1
1-6. Model Number and Name	1-1
1-8. Serial Numbers	1-1
1-10. Efficiency	1-1
II INSTALLATION	2-0
2-1. Unpacking and Inspection	2-0
2-2. General	2-0
2-4. CRT Warranty	2-0
2-6. Mounting	2-0
2-8. Storage and Shipment	2-0
2-9. Packaging	2-0
2-11. Environment	2-0
2-13. Connections	2-0
III OPERATION	3-1
3-1. Basic Concept	3-1
IV MAINTENANCE	4-0
4-1. Scheduling	4-0
4-3. Lubrication	4-0
4-5. Operator Adjustments	4-0
4-12. Cleaning	4-1
4-15. Calibration and Adjustment Procedure	4-1

LIST OF TABLES

1-1. Equipment Furnished	1-1
1-2. HP Equipment Available	1-1
1-3. Specifications	1-2
2-1. Input/Output Connectors	2-1
2-2. Incoming Inspection Check	2-6

LIST OF FIGURES

1-1. 5480A Signal Analyzer System	1-0
2-1. Rack Mounting	2-0
2-2. Connection of Sampling Oscilloscope to Extend Frequency Range	2-1
2-3. Connection of X-Y Display, Recorder, or Oscilloscope	2-1
3-1. Time to PRESET (Nomograph)	3-1
3-2. Pre-Analysis and Post-Analysis Delays	3-1
3-3. Memory-Display Unit (5480A)	3-2
3-4. Control Plug-in (5486A)	3-4
3-5. Two Channel Input Plug-in (5485A)	3-6
3-6. Setup and Turn-on	3-7
3-7. Average	3-8
3-8. Summation	3-10
3-9. Histograms	3-12
3-10. MCS (Multichannel Scaling)	3-13

Figure 1-1. 5480A Signal Analyzer System

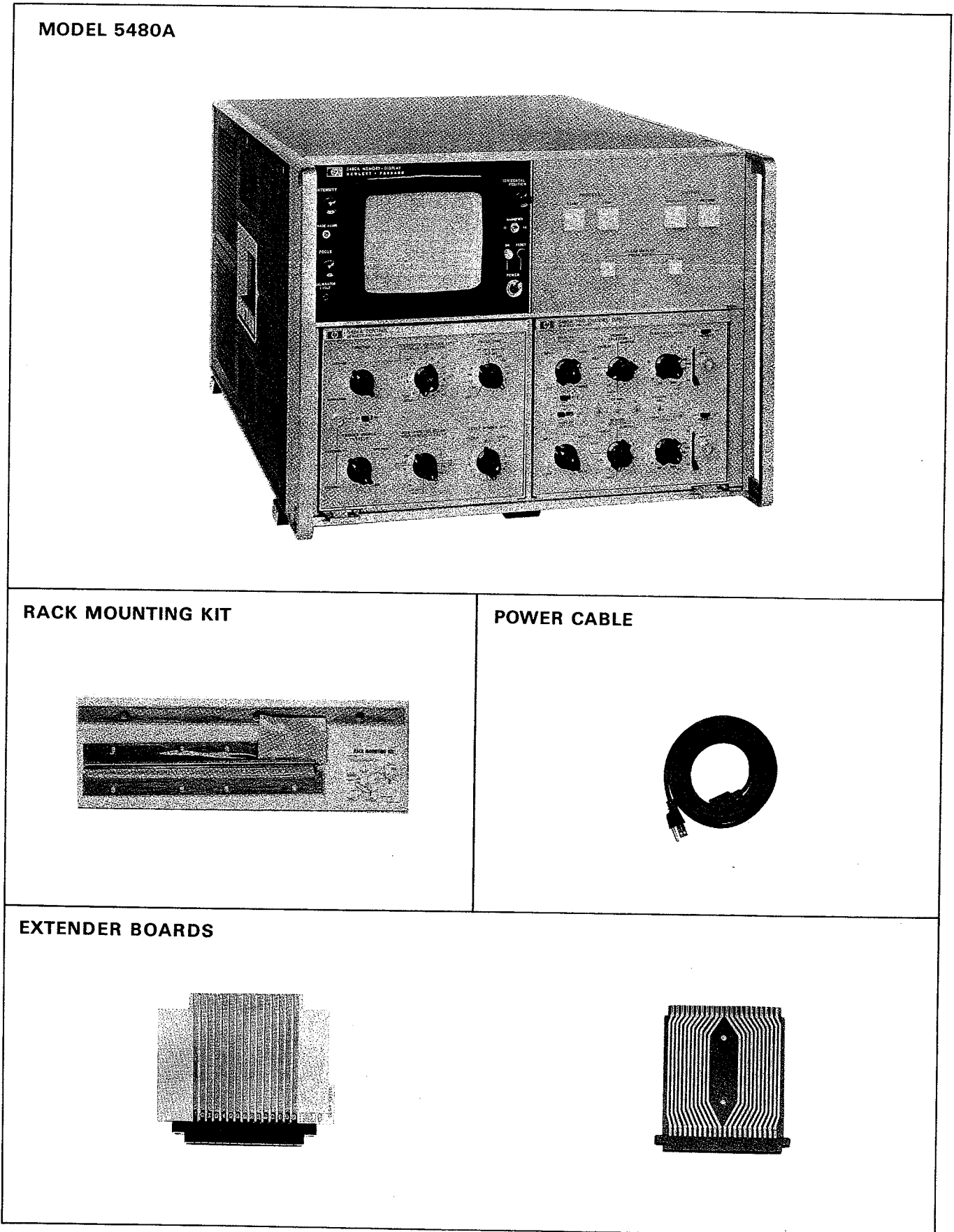

SECTION I GENERAL INFORMATION

1-1. INTRODUCTION

1-2. The Hewlett-Packard Model 5480A Signal Analyzer system is best described as an oscilloscope for looking at signals that are buried in noise. The 5480A can improve the signal-to-noise ratio of a waveform by as much as 1000 times (60 dB). Operating in real time, "on line", the 5480A enables the operator to see results while an experiment is in progress, even though its input signal may be so obscured by noise that raw data seem to contain little useful information.

1-3. Only three requirements must be placed on a system to enable use of the 5480A Signal Analyzer System:

a. The signal waveform must be repetitive (not necessarily periodic).

b. A sync pulse must be available to signal the beginning of each repetition. In some cases a sync pulse can be derived from a frequency synthesizer.

c. The highest frequency component of the input signal must be less than 50 kHz. However, this limit can be extended using a sampling oscilloscope (see Section III).

1-4. The 5480A Signal Analyzer (main frame) contains the Display, Memory, Main Frame Logic, Switching Logic, and Power Supply sections of the system. System functions are controlled by the left-hand plug-in, and input signals are handled by the right-hand plug-in.

1-5. INSTRUMENT IDENTIFICATION

1-6. Model Number and Name

1-7. Each unit in the Signal Analyzer is identified by Model number and name as a separate instrument; these are:

- Model 5480A Memory/Display (main frame unit)
- Model 5485A Two Channel Input (analog plug-in unit)
- Model 5486A Control (logic plug-in unit)

The Model 5480A Signal Analyzer System consists of the main frame unit and one logic plug-in and one analog plug-in; when using this Model number be sure to specify whether you are referring to the whole Signal Analyzer System or just to the Memory/Display unit.

1-8. Serial Numbers

1-9. Each unit in the Model 5480A Signal Analyzer system is identified by a two-section, eight-digit (000-00000) serial number located on rear panel of unit. The five-digit portion of the serial number is unique to each instrument; the three-digit portion is used to document changes. Include the complete serial number, Model number, and instrument name in correspondence about any unit in your Signal Analyzer.

Table 1-1. Equipment Furnished

Power Cord	HP Part No. 8120-0078
Rack Mounting Kit	HP Part No. 5060-0779

Table 1-2. HP Equipment Available

I/O Coupler (interfaces between Signal Analyzer and Computer, Digital Recorder, Tape Punch, Teleprinter, Tape Reader)	5495A
Computer	2114A, 2115A, 2116A
Digital Recorder	5050A, 562A
Tape Punch	2753A
Teleprinter	2752A
Tape Reader	2737A
Oscilloscope	120B
X-Y Display	1300A
X-Y Recorder	7004/with plug-ins
Point Plotter	
Sampling Oscilloscope (for increased frequency response)	140A with plug-ins, see Figure 2-2

1-10. EFFICIENCY

1-11. Efficiency in signal averaging is a measure of the time it takes to obtain a specified signal-to-noise ratio improvement; as efficiency increases, required time decreases. By adding a low-pass filter in series with the Signal Analyzer input, averaging time can be reduced since high-frequency noise can be removed by filtering instead of by averaging. In many situations, the system of which the Signal Analyzer is a part contains an amplifier which is bandlimited to suit the experiment. The upper cutoff frequency of the amplifier will in many applications provide sufficient filtering so that an added filter will not be required.

1-12. Cutoff frequency of the low-pass filter used to improve efficiency of the Signal Analyzer system depends on SWEEP TIME setting and the number of points to be used to represent the sharpest rise time of the input signal under study. The user will rarely choose to study a waveform with a rise time of fewer than five points.

EXAMPLE: SWEEP TIME is 100 msec/cm.

a. One 10 cm sweep takes 1 sec to complete. Since each sweep consists of 1000 points, each point represents 1 msec, and a rise time spanning 5 points in the display is 5 msec.

b. To convert rise time to frequency, divide rise time into ".35", frequency = .35/rise time. In this example, this becomes: cutoff frequency (highest displayed frequency) = .35/5 msec = 70 Hz. A low-pass filter at the Signal Analyzer input should pass this frequency and cut off all higher frequencies.

Table 1-3. Specifications

<p>AVERAGING: 3 methods. Up to 60 dB signal-to-noise ratio improvement.</p>	<p>Sweep Time: 1 msec/cm through 50 sec/cm in 1, 2, 5 steps</p>
<p>1. CALIBRATED AVERAGING MODE: Averager performs a true calibrated average. Waveform amplitudes are read directly from the CRT in volts/cm without normalizing.</p>	<p>Horizontal Magnifier: Expands horizontal axis by factor of 5.</p>
<p>Input Characteristics: (for 5485A 2 Channel Input plug-in):</p>	<p>External Time Base: Up to 20 kHz allows sweep times from 5 msec/cm to infinity.</p>
<p>Bandwidth: dc to 50 kHz</p>	<p>Sweep Number: Number of sweeps to be averaged may be preselected from 1 through 2^{19} (524,288) in powers of 2.</p>
<p>Sensitivity: 5 mV/cm to 20 V/cm in 1, 2, 5 steps.</p>	<p>dB Improvement: dB of signal-to-noise ratio improvement from 0 dB to 57 dB in 3 dB increments can be selected using sweep number control. Improvement approaches 60 dB with 2^{19} sweep number, normal (weighted average).</p>
<p>Input Impedance: 1 MΩ</p>	<p>Memory Selection: Operator may select any quarter, either half, or full memory (1000 points).</p>
<p>Maximum Input: 600V peak, ac coupled; dc coupled, 150V at 5 mV/cm, increasing to 350V at 20 V/cm.</p>	<p>Overlap Display: Two waveforms may be stored, while two more are processed; then all four displayed simultaneously for comparison.</p>
<p>Polarity Inversion: +UP or -UP selectable</p>	<p>Display: Operator may select CRT display of waveform as it is averaged, noise as it is removed from signal, or input signal after sampling.</p>
<p>A + B: Adds Channel B input to Channel A input and sum is fed through Channel A. Polarity of either channel may be inverted to give difference (A - B).</p>	<p>2. WEIGHTED AVERAGING: Averager is able to follow a slowly changing waveform by averaging only the most recent repetitions. Essentially the averager forgets old data in favor of the new. All specifications are identical with Calibrated Averaging.</p>
<p>ALT: Processes and displays both channels simultaneously.</p>	<p>3. SUMMATION MODE: In this mode the averager adds successive repetitions of the noise waveform, resulting in an uncalibrated display which is proportional to the averaged signal.</p>
<p>Resolution: 1000 points (or 500 or 250 by front-panel selector).</p>	<p>Sensitivity Multiplier: Manual adjustment allows scaling vertical up or down in power of two increments up to 64 counts/cm.</p>
<p>Sampling Rate: 2 samples/sec through 100,000 samples/sec in 1, 2, 5 steps.</p>	<p>Automatic Scaling: Provides automatic scaling down of vertical in power-of-two increments to keep display on screen.</p>
<p>Sample Time: 1.2 μsec</p>	<p>Stable Baseline: Always represents 0 volts.</p>
<p>ADC Clock Rate: 20 MHz</p>	<p>All other specifications are identical with Calibrated Averaging, except Weighted Averaging is not possible.</p>
<p>ADC Resolution: 9 bits from 50 sec/cm through 5 msec/cm; 7 bits at 2 msec/cm; 5 bits at 1 msec/cm.</p>	<p>HISTOGRAM MODE: Averager displays a probability versus frequency (or time interval) plot. The number of incoming pulses in a set gate time determines the memory location into which a count is placed. After several gate times, a distribution results.</p>
<p>ADC System Noise: < 1% from 50 sec/cm through 2 msec/cm and < 3% at 1 msec/cm (however, this noise is random and will be averaged out).</p>	<p>Input Characteristics: Bandwidth: dc to 5 MHz Sensitivity: 100 mV Input Impedance: 1 MΩ shunted by 30 pF</p>
<p>Triggering:</p>	
<p>External:</p>	
<p>Slope: + or - selectable</p>	
<p>Amplitude: >100 mV (<10 msec rise time).</p>	
<p>Trigger level is adjustable.</p>	
<p>Maximum Input: 170 volts peak</p>	
<p>Input Impedance: 1 MΩ shunted by 30 pF</p>	
<p>Internal: Sweep is triggered by internally generated pulse occurring at end of each sweep. This free-running mode is used to control experiment.</p>	
<p>Line: Sweep is triggered by line frequency.</p>	

Table 1-3. Specifications Cont'd.

Frequency Ranges: 100 Hz/cm through 10 MHz/cm in 1, 2, 5 steps.

Time Interval Ranges: 50 sec/cm through 1 msec/cm in 1, 2, 5 steps.

Preset Totalizer: If desired, operator may preset number of values to be histogrammed from 10^2 through 10^7 in powers of 10.

Sensitivity Multiplier: Expands vertical to 64 counts/cm in power-of-two increments.

MULTICHANNEL SCALING (MCS) MODE: Averager displays a plot of frequency versus time. The averager sweeps through memory remaining at each location for the set gate time. The number of counts placed in each location is determined by the number of incoming pulses occurring during the gate time.

Pulse Requirements:

Amplitude: >2V (20V max)

Maximum Repetition Rate: 1 MHz

Minimum Pulse Width: 500 ns

Pulse Pair Resolution: 500 ns

Input Impedance: 3 kΩ minimum

Dwell Time Per Channel: 10 μsec through 0.5 sec in 1, 2, 5 steps (external time base: 50 μsec to infinity).

Sweep Modes: Sawtooth or triangular sweep. External time base input allows any desired sweep shape.

Triggering: External triggering is possible on sawtooth sweep.

OUTPUTS

Analog:

X-Y Recorder:

X: 0 to +10V sweep ramp; 0.2% linearity

Y: -4 to +4V; output is proportional to CRT display (0.5V output per cm deflection); 0.2% linearity.

NOTE: These X and Y signals will drive other devices such as scopes, or NMR systems.

Pen Lift Signal: +5V = pen up; 0V = pen down

Z-Axis: +5 volt blanking pulses for scope (can be used to gate noise output).

Point Plotter: (typically Moseley 7004A)

Seek: +10V, >50 μsec pulse to tell point plotter to seek a null.

Plot: >+2V, 200 nsec pulse accepted from point plotter indicating plot is complete.

X-Y signals are same as above.

Sweep Voltage: 0 to +1 volt sweep ramp; conveniently adjusted by changing resistors to give output ramp going from 0V to any value between 0 to +10V.

Sync: "Pos" provides +12V, >0.5 μsec pulse at end of each sweep (plus post-analysis delay); "Neg" provides same except -12V.

Sampling Pulses: Pulses go from +5 volts to Ground and return to +5V once each time the input is sampled.

Pulse Width: 100 ns

Noise: Train of voltage pulses whose amplitude equals difference between input and average; amplitude is proportional to CRT display of noise (1/2V per cm deflection). (This signal can be gated with Z-axis output.)

Digital: Four 50-pin connectors interface the averager, through the 5495A I/O Coupler, to computers, teleprinters, tape readers, and printers. A direct interface to all HP computers is available.

PRE-ANALYSIS DELAY: Provides calibrated delay between triggering signal and start of sweep. Delay range 20 nsec to 0.5 sec in 1, 2, 5 steps, plus no delay.

DISPLAY: 8 x 10 cm rectangular display CRT with internal graticule. 500 kHz bandwidth. 10-bit horizontal and vertical resolution of digital display. 1, 2, or 4 trace display depending on input channels used and memory sectioning. Independent vertical position and gain adjust for each channel. Vertical expander permits selection of suitable 10-bit vertical display.

BACK PANEL CONNECTION: Complete access to analog and stored digital information. Also provides for remote control. Convenient interface with other equipment.

GENERAL

Power: 115/230V, 50-60 Hz, 175W.

Dimensions: (5480A)

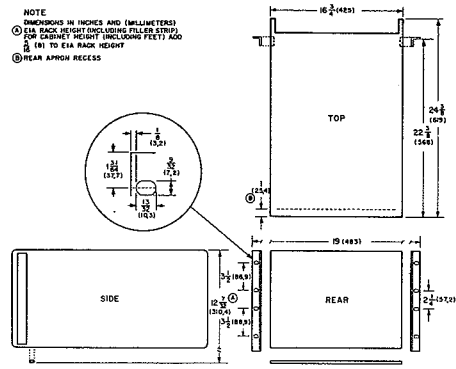

Weight: Net, 76 lb (34,5 kg) including HP 5485A and HP 5486A plug-ins.

SECTION II INSTALLATION

2-1. UNPACKING AND INSPECTION

2-2. General

2-3. If shipping carton is damaged, ask that carrier's agent be present when instrument is unpacked. Inspect instrument for damage (scratches, dents, broken knobs, etc.). If instrument is damaged or fails to operate (see Incoming Inspection Check, Table 2-2), notify carrier and nearest Hewlett-Packard Sales and Service office immediately. Sales and Service offices are listed at back of this manual. Retain shipping carton and padding material for carrier's inspection. Sales office will arrange for repair or replacement of your instrument without waiting for claim against carrier to be settled.

2-4. CRT Warranty

2-5. The 5480A and its plug-ins are certified and warranted as stated on inside front cover of this manual. The CRT, however, is covered by a warranty separate from the rest of the instrument. The CRT warranty and warranty claim forms are located at rear of this manual. Should CRT fail within time specified on warranty, return CRT with warranty form completed.

2-6. MOUNTING

2-7. The 5480A is shipped with logic and analog plug-ins installed, and is ready for bench operation when power and signal connections are made. Additional parts necessary for rack mounting are packaged with the system. Rack installation should allow a free flow of cooling air. To convert the Signal Analyzer for rack installation, refer to Figure 2-1 and proceed as follows:

Figure 2-1. Rack Mounting

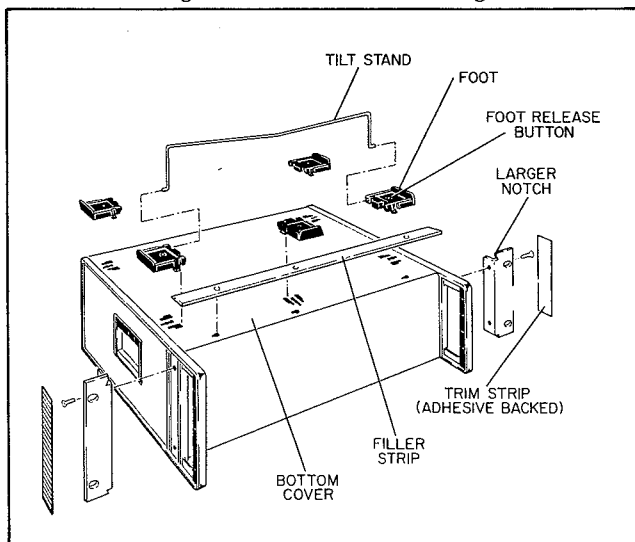

- a. Remove tilt stand.
- b. Remove feet (press the foot-release button, slide foot toward center of instrument, and lift off).
- c. Remove adhesive-backed trim strips at front end of sides.
- d. Attach filler strip along bottom edge of front panel.
- e. Attach flanges to front end of sides where trim strips were removed (larger corner notch of flange is toward bottom of instrument). The Signal Analyzer is now ready to mount in a standard rack.

2-8. STORAGE AND SHIPMENT

2-9. Packaging

2-10. To protect valuable electronic equipment during storage or shipment, always use the best packaging methods available. Your Hewlett-Packard Sales and Service office can provide packaging material such as that used for original factory packaging. Contract packaging companies in many cities can provide dependable custom packaging on short notice. Here are two recommended packaging methods:

- a. RUBBERIZED HAIR. Cover painted surfaces of instrument with protective wrapping paper. Pack instrument securely in strong corrugated container (350 lb/sq. in. bursting test) with 2-inch rubberized hair pads placed along all surfaces of instrument. Insert fillers between pads and container to ensure a snug fit.
- b. EXCELSIOR. Cover painted surfaces of instrument with protective wrapping paper. Pack instrument in strong corrugated container (350 lb/sq. in. bursting test) with a layer of excelsior about 6 inches thick packed firmly against all surfaces of instrument.

2-11. Environment

2-12. Conditions during storage and shipment should normally be limited as follows:

- a. Maximum altitude: 15K feet (4,5 km).
- b. Maximum temperature: +149°F (+65°C).
- c. Minimum temperature: -4°F (-20°C).

2-13. CONNECTIONS

2-14. Table 2-1 lists connections between Signal Analyzer units and external equipment. Internal Signal Analyzer connections are not listed here. Figures 2-2 and 2-3 show how to connect a sampling oscilloscope to increase frequency response and how to connect an X-Y Recorder, Point Plotter, or X-Y Display unit, for remote display or permanent record from the Signal Analyzer.

Figure 2-2. Connection of Sampling Oscilloscope to Extend Frequency Range

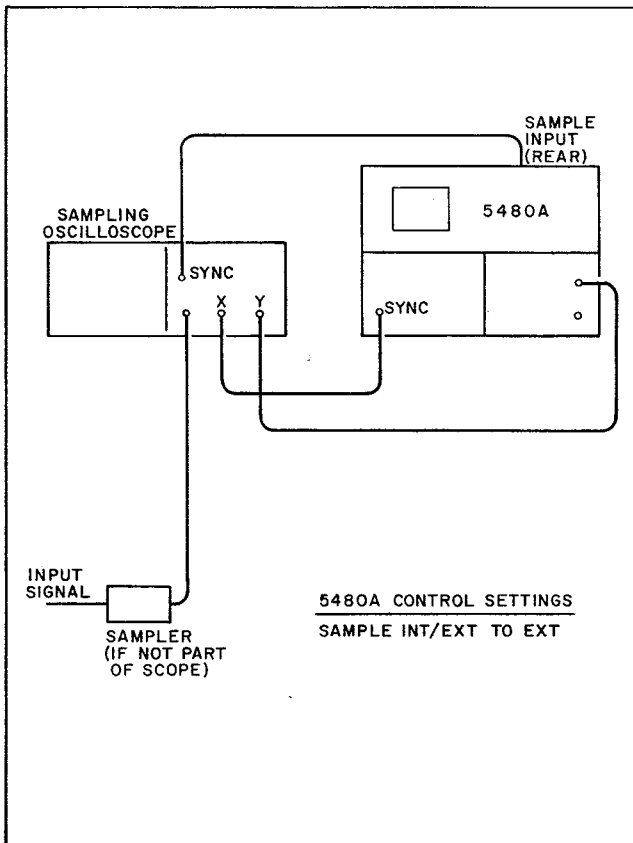

Figure 2-3. Connection of X-Y Display, Recorder, or Oscilloscope

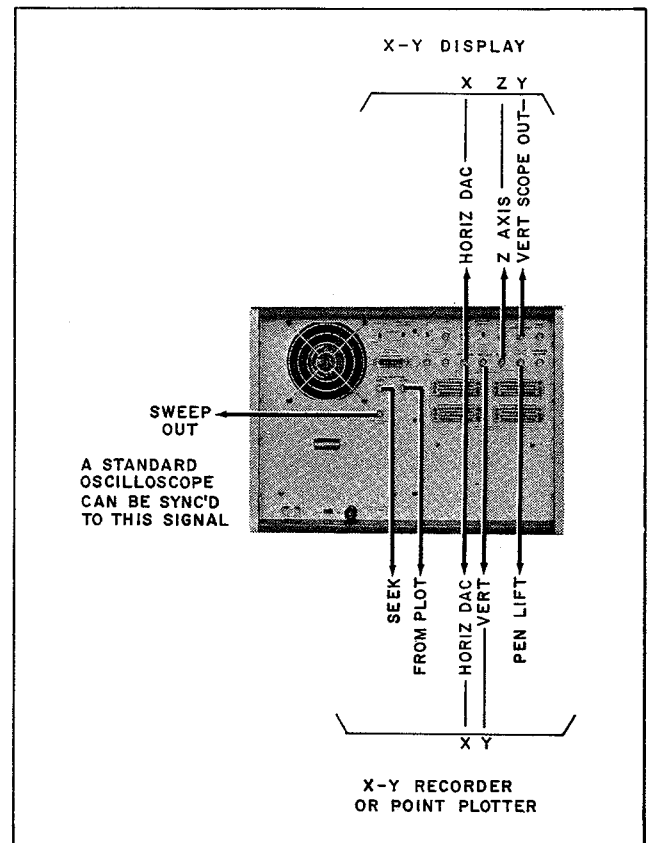

Table 2-1. Input/Output Connectors

A. MATING CONNECTORS		
Instrument Connector		Mating Connector
Reference Designator	Type (HP Part No.)	Type (HP Part No.)
J4-14, 19, 29-32	BNC Female	Standard BNC Male
J15-18	Body: Winchester MRAC 50S6 (1251-1921) Pin, female, 2-wire: Winchester 100-1016S (1251-1911) Pin, female, 1-wire: Winchester 100-1022S (1251-1909) Mtg. screws (set): Winchester J602 (1251-1911)	Body: Winchester MRAC 50P8 Pin, male: Winchester 100-1022P (1251-1908) Hood: Winchester 45-50H33/ES69 (1251-1922) Shell: Winchester XMRE 50-1000 (1251-1924) Mating Cable: (05495-60038)
J20	Connector: Power, 3-pin male (1251-0148)	Power cord (8120-0078)
A1J1	Connector: banana, female (1251-0463)	Connector: banana, male

Table 2-1. Input/Output Connectors Cont'd.

B. CONNECTOR WIRING

Connector	Signal Name	Signal Description
J4	SAMPLE INPUT	Frequency: < 20 kHz pulses, L = 0 V or more negative, H = +2 V or more positive.
J5	SAMPLE OUTPUT	Sample pulses, 1000 pulses per sweep. L = +0.4 V or more negative, H = +2.5 V or more positive.
J6	NOISE OUTPUT	Train of voltage pulses whose amplitude equals difference between INPUT and AVERAGE. Amplitude is proportional to CRT display of NOISE (0.5 V per cm of deflection). Can be gated with Z-AXIS OUTPUT.
J7	NEG SYNCH OUTPUT	Negative pulse at start of each sweep (before PRE-ANALYSIS DELAY). Level: -12 V; Width: > 0.5 μ sec.
J8	POS SYNCH OUTPUT	Positive pulse at start of each sweep (before PRE-ANALYSIS DELAY). Level: +12 V; Width: > 0.5 μ sec.
J9	HORIZ DAC OUTPUT	Sweep ramp. 0 V to +10 V; 0.2% linearity.
J10	VERT DAC OUTPUT	-4 V to +4 V, proportional to CRT display (0.5 V per cm deflection); 0.2% linearity.
J11	Z AXIS OUTPUT	+5 V blanking pulses (can be used to gate NOISE OUTPUT).
J12	EXTERNAL DATA INPUT	
J12(1-12)	Not used	
J12(13-24)	Not used	
J13	POINT PLOTTER SEEK	Positive pulse tells Point Plotter to seek a null. Level: +10 V; Width: > 50 μ sec.
J14	POINT PLOTTER PLOT	Positive pulse from Point Plotter indicates plot is complete. Level: > +2 V; Width: 200 nsec.

J15-J18, SYSTEM LOGIC INTERCONNECTION

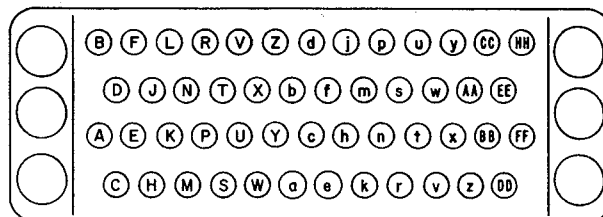

J15-J18 NOTES:

- | | |
|----------------------------------------------|-------------------------------------------------|
| H = +2.5 V or more positive voltage level | N = negative pulse, 200 nsec wide (H to L to H) |
| L = +0.4 V or more negative voltage level | P = positive pulse, 200 nsec wide (L to H to L) |
| A = voltage step from L to H (positive step) | LE = trigger (clock) on leading edge of pulse |
| B = voltage step from H to L (negative step) | TE = trigger (clock) on trailing edge of pulse |

Table 2-1. Input/Output Connectors Cont'd.

Connector	Signal Name	Description*	Connector	Signal Name	Description *
J15 SYSTEM LOGIC INTERCONNECTION A			J15(EE)	Not used	
J15(A)	Not used		J15(FF)	GRD	
J15(B)	Not used		J15(HH)	GRD	
J15(C)	CYCLE	N, LE	J16 SYSTEM LOGIC INTERCONNECTION B		
J15(D)	EN SHIFT IN	N, LE	J16(A)	EN SHIFT LEFT	N, LE
J15(E)	SET VERT	L = TRUE	J16(B)	EN SHIFT RIGHT	N, LE
J15(F)	CLEAR 1	L = TRUE	J16(C)	ENABLE COUNT	N, LE
J15(H)	SHIFT 1	N, LE	J16(D)	EN SHIFT IN	N, LE
J15(J)	Not used		J16(E)	EN OPEN LOOP	N, LE
J15(K)	Not used		J16(F)	CLEAR 1	L = TRUE
J15(L)	Not used		J16(H)	SHIFT 1	N, LE
J15(M)	EXT AR 0	L = TRUE	J16(J)	EN C UP A	N, TE
J15(N)	SHIFT PAR A	N, LE	J16(K)	EN C DN A	N, TE
J15(P)	EN C UP 20 MHz	L = TRUE	J16(L)	EN SHIFT RT PAR	N, LE
J15(R)	EN C DN 20 MHz	L = TRUE	J16(M)	EN COUNT PAR	N, LE
J15(S)	EXT AR 1	L = TRUE	J16(N)	SHIFT PAR A	N, LE
J15(T)	CLEAR PAR A	N, LE	J16(P)	ADVANCE PAR +1	N, TE
J15(U)	SET DAR		J16(R)	ADVANCE PAR -1	N, TE
J15(V)	SET HORIZ	N, LE	J16(S)	EN DAR TO PAR	N, LE
J15(W)	EXT AR 2	L = TRUE	J16(T)	CLEAR PAR A	N, LE
J15(X)	READ	N, LE	J16(U)	SET DAR	
J15(Y)	WRITE	N, LE	J16(V)	SET HORIZ	N, LE
J15(Z)	Not used		J16(W)	MOD HOLD	N, TE
J15(a)	EXT AR 3	L = TRUE	J16(X)	READ	N, LE
J15(b)	EN SHIFT IN PAR		J16(Y)	WRITE	N, LE
J15(c)	EXT PREP	N, LE	J16(Z)	AR 9	Output, L = TRUE
J15(d)	EXT AVE	N, LE	J16(a)	PAR 0	Output, L = TRUE
J15(e)	EXT AR 4	L = TRUE	J16(b)	SHIFT RT PAR C	L = TRUE
J15(f)	Not used		J16(c)	SAAR 0	L = TRUE
J15(h)	SET L DISPLAY	Output, N, LE	J16(d)	SBAR 0	L = TRUE
J15(j)	START ADC	Output, L = TRUE	J16(e)	SBAR 1	L = TRUE
J15(k)	EXT AR 5	L = TRUE	J16(f)	SAAR 1	L = TRUE
J15(m)	Not used		J16(h)	AR 0	Output, L = TRUE
J15(n)	CS ATTACHED	L = TRUE	J16(j)	AR 1	Output, L = TRUE
J15(p)	L STOP	Output, L = TRUE	J16(k)	MAIN SRQ	L = TRUE
J15(r)	EXT AR 6	L = TRUE	J16(m)	SUB SRQ	L = TRUE
J15(s)	Not used		J16(n)	MBSL	Output; L = TRUE
J15(t)	Not used		J16(p)	OUTPUT MPX	Output, L = TRUE
J15(u)	Not used		J16(r)	L DISPLAY	Output, L = TRUE
J15(v)	EXT AR 7	L = TRUE			
J15(w)	Not used				
J15(x)	Not used				
J15(y)	Not used				
J15(z)	EXT AR 8	L = TRUE			
J15(AA)	ENABLE PAR TO HOLD				
J15(BB)	Not used				
J15(CC)	Not used				
J15(DD)	EXT AR 9	L = TRUE			

* SEE J15-J18 NOTES.

Table 2-1. Input/Output Connectors Cont'd.

Connector	Signal Name	Description*	Connector	Signal Name	Description*
J16(s)	CHANNEL COMMAND	L = TRUE	Y	<u>EXT AC 5</u> AC 5	L = TRUE Output,
J16(t)	+5 volts	Output	Z		H = TRUE
J16(u)	<u>SAAR 2</u>	L = TRUE	a	<u>EXT AC 17</u>	L = TRUE
J16(v)	<u>SAAR 3</u>	L = TRUE	b	AC 17	Output,
J16(w)	ADVANCE PAR +4	L = TRUE			H = TRUE
J16(x)	ADVANCE PAR +2	L = TRUE	c	<u>EXT AC 6</u>	L = TRUE
J16(y)	INTENSITY MOD	L = TRUE	d	AC 6	Output,
J16(z)	START PBM	L = TRUE			H = TRUE
J16(AA)	ENABLE PAR TO HOLD		e	<u>EXT AC 18</u>	L = TRUE
J16(BB)	STOP PBM	L = TRUE	f	AC 18	Output,
					H = TRUE
J16(CC)	DISPLAY PBM	L = TRUE	h	<u>EXT AC 7</u>	L = TRUE
J16(DD)	RECORD PBM	L = TRUE	j	AC 7	Output,
J16(EE)	CLEAR DISPLAY	L = TRUE			H = TRUE
J16(FF)	GRD		k	<u>EXT AC 19</u>	L = TRUE
J16(HH)	GRD		m	AC 19	Output,
					H = TRUE
			n	<u>EXT AC 8</u>	L = TRUE
			p	AC 8	Output,
					H = TRUE
			r	<u>EXT AC 20</u>	L = TRUE
			s	AC 20	Output,
					L = TRUE
			t	<u>EXT AC 9</u>	L = TRUE
			u	AC 9	Output,
					H = TRUE
			v	<u>EXT AC 21</u>	L = TRUE
			w	AC 21	Output,
					H = TRUE
			x	<u>EXT AC 10</u>	L = TRUE
			y	AC 10	Output,
					H = TRUE
			z	<u>EXT AC 22</u>	L = TRUE
			AA	AC 22	Output,
					H = TRUE
			BB	<u>EXT AC 11</u>	L = TRUE
			CC	AC 11	Output,
					H = TRUE
			DD	<u>EXT AC 23</u>	L = TRUE
			EE	AC 23	Output,
					H = TRUE
			FF	GRD	
			HH	GRD	
<p>J17, J18 SYSTEM INTERCONNECTION C1, C2. These connectors are wired in parallel. Signal appears at indicated pin of either connector.</p>					
A	<u>EXT AC 0</u>	L = TRUE			
B	AC 0	Output,			
		H = TRUE			
C	<u>EXT AC 12</u>	L = TRUE			
D	AC 12	Output,			
		H = TRUE			
E	<u>EXT AC 1</u>	L = TRUE			
F	AC 1	Output,			
		H = TRUE			
H	<u>EXT AC 13</u>	L = TRUE			
J	AC 13	Output,			
		H = TRUE			
K	<u>EXT AC 2</u>	L = TRUE			
L	AC 2	Output,			
		H = TRUE			
M	<u>EXT AC 14</u>	L = TRUE			
N	AC 14	Output,			
		H = TRUE			
P	<u>EXT AC 3</u>	L = TRUE			
R	AC 3	Output,			
		H = TRUE			
S	<u>EXT AC 15</u>	L = TRUE			
T	AC 15	Output,			
		H = TRUE			
U	<u>EXT AC 4</u>	L = TRUE			
V	AC 4	Output,			
		H = TRUE			
W	<u>EXT AC 16</u>	L = TRUE			
X	AC 16	Output,			
		H = TRUE			

* SEE J15-J18 NOTES.

Table 2-1. Input/Output Connectors Cont'd.

Connector	Signal Name	Signal Description
J19	SWEEP VOLTAGE OUTPUT	Sweep ramp, 0 V to +1 V (0 V to any value < +10 V obtainable by changing internal resistor).
J20	AC POWER	AC power input 115 or 230 V.
J29	VERTICAL SCOPE OUTPUT	-5 V to +5 V, proportional to CRT display. Analog Plug-in (API) POSITION control determines dc offset of this signal.
J30	PEN LIFT CONTROL	Output, +5 V = Pen UP; 0 V = Pen DOWN
J31	MCS INPUT	Signal input for MCS FUNCTION. Pulses; amplitude between 2 V and 20 V; max rep rate 1 MHz; min width 500 nsec; pulse pair resolution 500 nsec; input impedance 3 K ohms minimum.
J32	VARIANCE OUTPUT	Square of noise signal available only when variance option installed in API (5485A Option 01).
A1J1	CALIBRATOR	Square wave, 1 V p-p. Frequency depends on LPI SWEEP TIME setting.

Table 2-2. Incoming Inspection Check

This table lists equipment and methods required to perform an incoming inspection check of the Model 5480A Signal Analyzer. Before beginning the check, refer to Section III of this manual for a discussion of operating controls for the 5480A Memory/Display unit and its two plug-ins.

This table is organized in three sections:

- A. Test equipment required, with recommended Hewlett-Packard instruments listed.
- B. Procedure, describing tests.
- C. Test record, which provides a place to record the results of each test. The test record may be kept as a reference against which later performance checks can be compared.

A. TEST EQUIPMENT REQUIRED

Type/Characteristics	Recommended HP Instrument (other equipment may be used, if it has required characteristics)
Electronic Counter	Model 5221B
Voltage Standard	
DC: Output voltage range +20 mV to +20 V	Model 740B or 741B
AC: Output voltage range 0.5 V to 20 V peak-to-peak	Model 745A
	(Note: Model 738AR Voltmeter Calibrator may be used. Model 738BR Voltmeter Calibrator may be used, except change test voltages that are multiples of "2" to multiples of "1.5".)
Oscilloscope	Model 180A with
Vertical Sensitivity: 5 V/cm	Model 1801A Dual Channel Vertical Amplifier
Sweep Speeds: 1 μ sec/cm to 100 msec/cm	and Model 1820 Time Base plug-ins
Intensity modulation capability	
Pulse Generator	Model 222A
Repetition rate 1K to 1M	
Pulse width 0.5 μ sec	
Positive polarity	
Amplitude 2V	
Strip Chart Recorder	Model 680

B. PROCEDURE

1. Before turn-on, set Signal Analyzer System controls as follows:

FUNCTION to AVERAGE	MAGNIFIER to X1
TRIGGER SOURCE to INTERNAL	SCALE CAL to OFF
PRE-ANALYSIS DELAY to "0"	SAMPLE to INT
POST-ANALYSIS DELAY to OFF	DISPLAY INTERLACE to IN
SWEEP NUMBER to "0"	SAWTOOTH/TRIANGLE to SAWTOOTH
PRESET/NORMAL to NORMAL	A DISPLAY to DATA
SWEEP TIME to 1 sec/cm	B DISPLAY to DATA
SENSITIVITY MULTIPLIER to AUTO	A MEMORY SELECTOR to HALF 3, 4
PRESET TOTALIZER to OFF	

Table 2-2. Incoming Inspection Check Cont'd.

B. PROCEDURE Cont'd.

1. Set controls as follows (Cont'd):
 - B MEMORY SELECTOR to HALF 1,2
 - A+B/ALT to ALT
 - HISTOGRAM to OFF
 - A SENSITIVITY to .005 V/CM
 - B SENSITIVITY to .005 V/CM
 - A SENSITIVITY VERNIER to CAL
 - B SENSITIVITY VERNIER to CAL
 - A POLARITY to UP+
 - B POLARITY to UP+
 - A AC/GND/DC to GND
 - B AC/GND/DC to GND
2. Check for correct line fuse and line voltage switch setting (see item 16, Figure 3-3), then connect Signal Analyzer System to ac line and turn on POWER.
 - Observe that:
 - POWER lamp is lighted
 - RESET lamp is off
 - PROCESS STOP pushbutton is lighted
3. Press both CLEAR DISPLAY pushbuttons. Observe that OUTPUT DISPLAY pushbutton lights, and two traces appear on CRT.
4. Adjust A POSITION. Observe that one trace moves across entire vertical range of CRT graticule.
5. Adjust B POSITION. Observe that other trace moves across entire range of CRT graticule.
6. Set Channel A trace on top graticule line. Set Channel B trace on bottom graticule line. Observe trace widths. Adjust FOCUS for best traces. Traces should be less than 0.2 cm wide.
7. Switch MAGNIFIER to X5. Observe that each trace has approximately 10 dots per cm.
8. Adjust HORIZONTAL POSITION. Observe both ends of traces as position control is moved from one extreme to the other.
9. Switch Channel A MEMORY SELECTOR to QUARTERS 1, 2, 3, and 4. Observe that Channel A trace has approximately 5 dots per cm for each quarter.
10. Switch Channel A DISPLAY to OFF. Switch Channel B MEMORY SELECTOR to QUARTERS 1, 2, 3, and 4. Observe that Channel B trace has approximately 5 dots per cm for each quarter. Channel A trace should not be present.
11. Set controls as follows:
 - A DISPLAY to DATA
 - A MEMORY SELECTOR to FULL
 - B MEMORY SELECTOR to FULL
 - MAGNIFIER to X1
 - A+B/ALT to A+B
 - Press both CLEAR DISPLAY buttons
 - Press PROCESS START pushbutton

Observe trace. If trace contains a moving offset, adjust DC BAL A+B to minimize offset. To check adjustment, press both CLEAR DISPLAY pushbuttons, then PROCESS START pushbutton; observe moving offset, and repeat adjustment if necessary.
12. Press both CLEAR DISPLAY pushbuttons, then PROCESS START. Switch Channel A POLARITY alternately between UP+ and -UP. Observe trace. Offsets associated with polarity switching should be less than 0.2 cm.

Table 2-2. Incoming Inspection Check Cont'd.

B. PROCEDURE Cont'd.

13. Press both CLEAR DISPLAY pushbuttons, then PROCESS START. Switch Channel B POLARITY alternately between UP+ and -UP. Observe trace. Offsets associated with polarity switching should be less than 0.2 cm.
14. Switch A+B/ALT to ALT. Press both CLEAR DISPLAY pushbuttons, then PROCESS START. Observe trace. If trace contains a moving offset, adjust Channel A DC BAL for minimum offset. To check adjustment, press both CLEAR DISPLAY pushbuttons, then PROCESS START pushbutton; observe moving offset, and repeat adjustment if necessary.
15. Switch Channel A DISPLAY to OFF. Press both CLEAR DISPLAY pushbuttons, then PROCESS START. Observe trace. If trace contains a moving offset, adjust Channel B DC BAL for minimum offset. To check adjustment, press both CLEAR DISPLAY pushbuttons, then PROCESS START pushbutton; observe moving offset, and repeat adjustment if necessary.
16. Press OUTPUT DISPLAY. Switch SENSITIVITY MULTIPLIER to "0", then in sequence through 1, 2, 3, 4, 5, 6, 7, etc. Observe trace. There should be no change switching between AUTO and "0". As SENSITIVITY MULTIPLIER is stepped to each higher-numbered position, vertical spacing between dots of trace doubles.
17. Set controls as follows:
 SENSITIVITY MULTIPLIER to AUTO
 SWEEP TIME to 10 msec/cm
 INTERLACE DISPLAY to OUT
 Press PROCESS START

Observe trace. Trace should flicker.
18. Switch SWEEP TIME through each position from 10 msec/cm to 50 sec/cm. Observe trace. With each successive switch position, trace should flicker at a slower rate until display is a dot slowly moving across CRT.
19. Switch SWEEP TIME to 1 msec/cm. Set PRE-ANALYSIS DELAY to 0.5 sec. Observe trace. Flicker rate should be about two times per second.
20. Switch PRE-ANALYSIS DELAY to 0.2 sec, 0.1 sec, 50 msec, and 20 msec. Observe trace. Flicker rate should increase as PRE-ANALYSIS DELAY decreases.
21. Switch PRE-ANALYSIS DELAY to 10 msec and 5 msec. Observe trace. Trace should brighten at each of these PRE-ANALYSIS times.
22. Set PRE-ANALYSIS DELAY to "0". Set POST-ANALYSIS DELAY to any position out of "OFF". Observe trace. Flicker rate depends on setting of POST-ANALYSIS DELAY.
23. Switch TRIGGER SOURCE to LINE. Observe trace. Flicker rate depends on POST-ANALYSIS DELAY setting.
24. Set controls as follows:
 POST-ANALYSIS DELAY to OFF
 SWEEP NUMBER to "0"
 PRESET/NORMAL to NORMAL
 Press PROCESS START pushbutton

Connect a BNC-BNC cable between Electronic Counter INPUT and 5480A rear-panel NEG SYNCH OUTPUT.

Set Electronic Counter as follows:
 GATE to OPEN
 SAMPLE RATE to mid-range
 TRIGGER LEVEL for uniform counting rate.

Table 2-2. Incoming Inspection Check Cont'd.

B. PROCEDURE Cont'd.

24. Continued.

Switch SWEEP NUMBER to PRESET.
Press both CLEAR DISPLAY pushbuttons
Reset Electronic Counter
Press PROCESS START button

Observe 5480A and Electronic Counter. Signal Analyzer should provide one sweep, and OUTPUT DISPLAY button should light. Electronic Counter should indicate "1" sweep.

25. Perform the following procedure for SWEEP NUMBER settings indicated:

Set SWEEP NUMBER switch as indicated.
Reset Electronic Counter
Press PROCESS START button
Allow Signal Analyzer to sweep until OUTPUT DISPLAY lamp lights.

Observe Electronic Counter display. Number of sweeps should correspond to selected SWEEP NUMBER as shown in table below.

SWEEP NUMBER	Number of sweeps
1	2
2	4
3	8
4	16
5	32
6	64
7	128
8	256
9	512
10	1024

Disconnect Electronic Counter from 5480A.

26. Connect equipment as shown in setup diagram below.

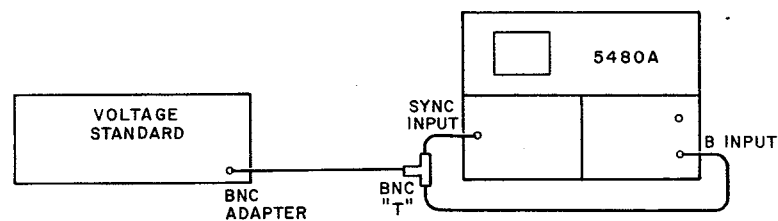

Center Channel B trace
Switch Channel B AC/GND/DC to DC
Set Voltmeter Calibrator for +20 mV dc output
Observe trace. At 5 mV/cm, trace should move to within 0.2 cm of top graticule line.

27. Switch Channel B POLARITY to -UP. Observe trace. Trace should move to within 0.2 cm of bottom graticule line.

Table 2-2. Incoming Inspection Check Cont'd.

B. PROCEDURE Cont'd.

28. Switch Channel B SENSITIVITY to .01 V/CM, .02 V/CM, and .05 V/CM. Observe trace. Displacement from center should correspond to SENSITIVITY setting as shown in chart below, within 0.2 cm.

SENSITIVITY (V/CM)	Trace is _____ cm below center (± 0.2 cm)
.01	2 cm
.02	1 cm
.05	0.4 cm

29. Change control settings as follows:

Voltage Standard to provide 400 Hz at 0.5 V peak-to-peak
Channel B SENSITIVITY to 0.1 V/CM
TRIGGER SOURCE to EXTERNAL +
Adjust TRIGGER SOURCE LEVEL for stable triggering

Observe trace. Pattern should be stable sine wave, 5 ± 0.2 cm in height.

30. Adjust Channel B SENSITIVITY VERNIER. Observe trace. Vernier should reduce height of displayed signal to less than 2 cm when turned fully CCW. Set B SENSITIVITY VERNIER to CAL.

31. Switch Channel B SENSITIVITY and Voltmeter Calibrator output as indicated in table below. Observe trace. Display size at each setting should be within 0.2 cm of size indicated in table.

DC Voltage Standard Output	SENSITIVITY (V/CM)	Display Size (cm)
0.5V	0.2	2.5
0.5V	0.5	1
1V	1	1
2V	2	1
5V	5	1
10V	10	1
20V	20	1

32. Switch Channel A DISPLAY to DATA and repeat steps 26 through 31 for Channel A.

33. Switch PRE-ANALYSIS DELAY to 20 μ s, 50 μ s, .1 ms, .2 ms, .5 ms, 1 ms, and 2 ms. Observe trace. Initial phase of displayed sine wave should change as switch settings are changed.

34. Switch TRIGGER SOURCE to EXTERNAL. Observe trace. Phase of displayed sine wave should reverse.

35. Set controls as follows:

PRE-ANALYSIS DELAY to "0"
SWEEP TIME to 5 msec/cm
FUNCTION to SUMMATION
SWEEP NUMBER to "4"
PRESET/NORMAL to PRESET
Press both CLEAR DISPLAY pushbuttons
Press PROCESS START button

Observe trace. Sine wave pattern should grow, divide by 2, grow, divide by 2, for a total of four divisions by 2.

36. Switch SENSITIVITY MULTIPLIER to 10. Observe trace. Sine wave displayed should be 0.5 ± 0.2 cm in amplitude.

Table 2-2. Incoming Inspection Check Cont'd.

B. PROCEDURE Cont'd.

37. Switch SENSITIVITY MULTIPLIER to 11, 12, 13, 14, 15. Observe trace. Amplitude of displayed sine wave should double with each successive switch position. Note: there may be a small amount of overflow on position 15. Overflow causes displayed pattern to appear folded-over at top or bottom.
38. Set controls as follows:
SENSITIVITY MULTIPLIER to AUTO
SWEEP NUMBER to 19
Channel A DISPLAY to INPUT
Press both CLEAR DISPLAY pushbuttons
Press PROCESS START button
- Observe trace. Should be flickering sine wave.
39. Switch Channel A DISPLAY to NOISE. Observe trace. Should be flickering sine wave, same as in step 38.
40. Switch SWEEP TIME to 10 msec/cm. Observe trace. Flicker is half rate of step 39.
41. Set controls as follows:
FUNCTION to AVERAGE
Channel A SENSITIVITY to 0.5 V/CM
Channel A DISPLAY to DATA
SWEEP TIME to 2 msec/cm
Channel A SENSITIVITY VERNIER to fully CCW
Press both CLEAR DISPLAY pushbuttons
Press PROCESS START button
- Observe trace. Should be clipped sine wave with no "rain". "Rain" is many dots moving randomly up or down in the CRT display.
42. For the remaining checks of this procedure, an external oscilloscope is used to observe Signal Analyzer output waveforms. Initially, the oscilloscope controls should be set as follows:
Time/cm to 1 μ sec/cm
Vertical sensitivity to 5 V/CM
AC/DC coupling to DC
SYNC to internal
43. Connect oscilloscope to 5480A rear-panel POS SYNCH OUTPUT.
Set 5486A TRIGGER SOURCE to INT
Press both CLEAR DISPLAY pushbuttons
Press PROCESS START button
- Observe oscilloscope. Display should be positive-going pulse as shown in waveform A.
44. Disconnect oscilloscope from POS SYNCH OUTPUT and connect to NEG SYNCH OUTPUT. Observe oscilloscope. Display should be negative-going pulse as shown in waveform B.
45. Disconnect oscilloscope from NEG SYNCH OUTPUT and connect to SAMPLE OUTPUT. Observe oscilloscope. Display should be negative-going pulse as shown in waveform C.
46. Disconnect oscilloscope from SAMPLE OUTPUT and connect to Z AXIS OUTPUT. Observe oscilloscope. Display should be negative-going pulse as shown in waveform D.

Table 2-2. Incoming Inspection Check Cont'd.

B. PROCEDURE Cont'd.

OSCILLOGRAMS

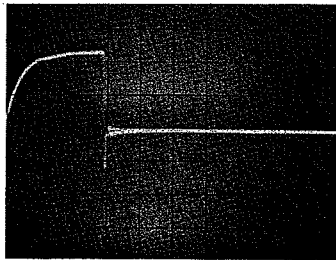

1. $V = 5V/cm$
 $H = 0.5 \mu sec/cm$
0V = vertical centerline

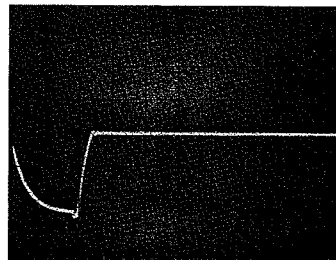

2. $V = 5V/cm$
 $H = 0.5 \mu sec/cm$
0V = vertical centerline

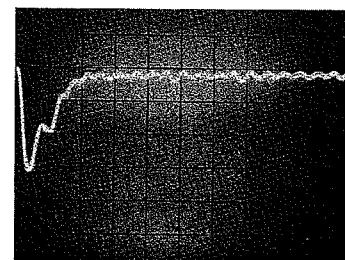

3. $V = 2V/cm$
 $H = 0.1 \mu sec/cm$
0V = vertical centerline

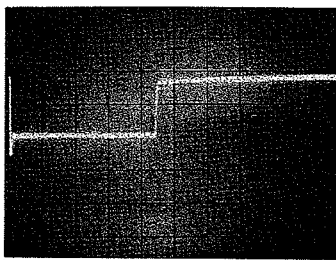

4. $V = 2V/cm$
 $H = 1 \mu sec/cm$
0V = vertical centerline

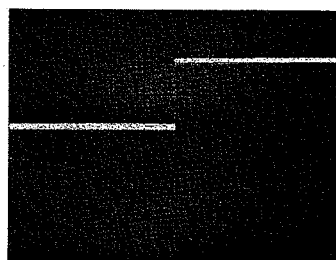

5. $V = 2V/cm$
 $H = 2 msec/cm$
0V = vertical centerline

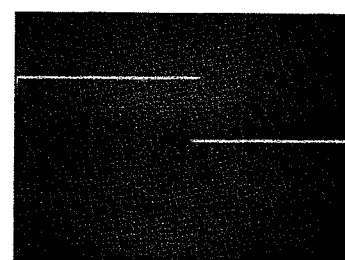

6. $V = 5V/cm$
 $H = 20 \mu sec/cm$
0V = vertical centerline

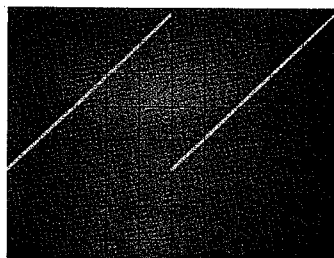

7. $V = 1V/cm$
 $H = 1 sec/cm$
0V = 1 cm below vertical centerline

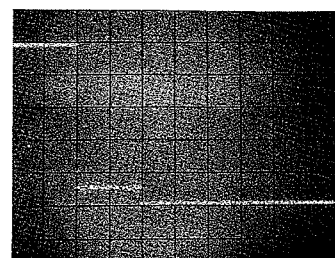

8. $V = 20 kHz/cm$
 $H = 10 sec/cm$
0 counts = baseline
SENSITIVITY MULTIPLIER set to 9

47. Disconnect oscilloscope from Z AXIS OUTPUT and connect to PEN LIFT CONTROL.

Change oscilloscope time/cm to 5 msec/cm
Press both CLEAR DISPLAY buttons
Press OUTPUT RECORD button, repeat as many times as desired.

Observe oscilloscope. Display should be negative-going pulse as shown in waveform E. Pulse occurs each time OUTPUT RECORD button is pressed.

48. Disconnect oscilloscope from PEN LIFT CONTROL and connect to POINT PLOTTER SEEK.

Change oscilloscope time/cm to 20 $\mu sec/cm$
Change 5480A SWEEP TIME to 100 msec/cm
Press OUTPUT RECORD button. Repeat as necessary.

Observe oscilloscope. Positive pulse occurs during time OUTPUT RECORD button is lighted. OUTPUT RECORD stays lighted for about 1 second (10 times SWEEP TIME setting). Pulse should resemble one shown in waveform F. Disconnect oscilloscope from POINT PLOTTER SEEK output.

Table 2-2. Incoming Inspection Check Cont'd.

B. PROCEDURE Cont'd.

49. Connect Pulse Generator OUTPUT to POINT PLOTTER PLOT input. Set Pulse Generator controls as follows:

REP RATE to 1K-10K	PULSE WIDTH VERNIER to fully CCW
REP RATE VERNIER to fully CCW	PULSE POLARITY to "+"
PULSE DELAY to less than 0.1	PULSE AMPLITUDE to 2V
PULSE WIDTH to 0.5-5	PULSE AMPLITUDE VERNIER fully CCW

Set 5480A controls as follows:

SAMPLE INT/EXT to EXT
SWEEP TIME to EXT
Push OUTPUT RECORD button

Observe 5480A CRT. Dot moves across CRT. PROCESS STOP button lights about 1 to 2 seconds after OUTPUT RECORD button is pressed. Disconnect Pulse Generator from POINT PLOTTER PLOT input.

50. Connect Pulse Generator to SAMPLE INPUT. Press both CLEAR DISPLAY pushbuttons. Press PROCESS START button. Observe CRT. Dot sweeps across CRT in about 1 to 2 seconds. Disconnect Pulse Generator from SAMPLE INPUT.
51. Connect Pulse Generator to MCS INPUT. Change Pulse Generator REP RATE to 100K-1M. Set 5480A controls as follows:

SAMPLE INT/EXT to EXT
SWEEP TIME to 1 sec/cm
FUNCTION to MCS
SENSITIVITY MULTIPLIER to 7
Press both CLEAR DISPLAY pushbuttons
Press PROCESS START button

After about 1 second, change Pulse Generator REP RATE to 10K-100K. After about 1 more second, push PROCESS STOP. Press DISPLAY. Observe CRT. Disregard scattered points. If two-step picture, similar to one shown in waveform G, appears, MCS works. Disconnect all signal leads from 5480A rear-panel.

52. Connect oscilloscope as shown in picture below.

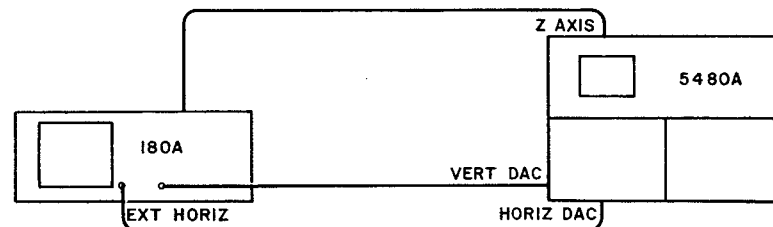

Set oscilloscope controls as follows:

DISPLAY to EXT CAL
Vertical Sensitivity to 0.5 V/cm
Adjust Horizontal and Vertical position controls as necessary for on-screen display.

Observe waveforms on Signal Analyzer and oscilloscope. They should be similar. Adjust Horizontal and Vertical gain sensitivities to give same Horizontal and Vertical deflections on oscilloscope as on Signal Analyzer. Oscilloscope trace should be twice as wide as Signal Analyzer trace. NOTE: Be sure oscilloscope intensity control is not turned up so high that it overrides Z axis input voltage.

Table 2-2. Incoming Inspection Check Cont'd.

B. PROCEDURE Cont'd.

53. Disconnect oscilloscope from VERTICAL DAC OUTPUT and connect to VERTICAL SCOPE OUTPUT. Adjust Signal Analyzer Vertical POSITION control. Observe oscilloscope trace. Trace should move up and down as Signal Analyzer trace moves up and down.

54. Set controls as follows:
 - FUNCTION to HISTOGRAM
 - HISTOGRAM to TIME
 - SWEEP TIME to 1 msec/cm
 - SENSITIVITY MULTIPLIER to 15
 - Press both CLEAR DISPLAY pushbuttons
 - Press PROCESS START buttonObserve 5480A CRT. One to three dots should rise out of baseline approximately 2.5 cm from left-hand side.

55. Switch HISTOGRAM to FREQ, and SWEEP TIME to 5 sec/cm. Press both CLEAR DISPLAY pushbuttons. Press PROCESS START button. Observe 5480A CRT. One to three dots will slowly rise about 0.2 cm from left-hand end of baseline.

56. Connect Strip Chart Recorder to 5480A SWEEP VOLTAGE OUTPUT. Set recorder as follows:
 - RANGE to 1V
 - DCN to DOWN
 - Division to "8"
 - Min/Hr to Min
 - Zero pen while holding 5480A OUTPUT RECORD button in.Set Signal Analyzer controls as follows:
 - INTERLACE DISPLAY to OUT
 - PRESET/NORMAL to NORMAL
 - Press PROCESS STARTObserve strip chart recording. Should show a ramp as in picture H.

Table 2-2. Incoming Inspection Check Cont'd.

C. TEST RECORD

HP Model 5480A Signal Analyzer System Tests performed by _____
 HP Model 5480A Memory/Display Serial No. _____ - _____ Other ID _____ Date _____
 HP Model 5485A Dual Channel Input Serial No. _____ - _____ Other ID _____
 HP Model 5486A Control Serial No. _____ - _____ Other ID _____

Step*	Description	Test Result
* Step refers to number in part B, PROCEDURE		
1.	Initial Control Settings	
2.	Turn-on	POWER lamp _____ RESET lamp _____ PROCESS STOP button _____
3.	CLEAR DISPLAY	OUTPUT DISPLAY button _____ CRT Display _____
4.	Channel A POSITION	One trace moves _____
5.	Channel B POSITION	Other trace moves _____
6.	Trace widths	Less than 0.2 cm _____
7.	MAGNIFIER to X5	10 dots/cm A _____ B _____
8.	HORIZONTAL POSITION	See both ends of trace _____
9.	Channel A MEMORY SELECTOR	QUARTER 1 _____ 2 _____ 3 _____ 4 _____
10.	Channel B MEMORY SELECTOR	QUARTER 1 _____ 2 _____ 3 _____ 4 _____
11.	DC BAL A+B	Minimal offset _____
12.	Channel A POLARITY reversal	Minimal offset _____
13.	Channel B POLARITY reversal	Minimal offset _____
14.	DC BAL A	Minimal offset _____
15.	DC BAL B	Minimal offset _____
16.	SENSITIVITY MULTIPLIER	No change in size switching between AUTO and "0" _____

Table 2-2. Incoming Inspection Check Cont'd.

C. TEST RECORD Cont'd.		
16.	SENSITIVITY MULTIPLIER Cont'd.	Vertical spacing between dots changes by factor of 2 when switching between following positions 0-1 _____ 10-11 _____ 1-2 _____ 11-12 _____ 2-3 _____ 12-13 _____ 3-4 _____ 13-14 _____ 4-5 _____ 14-15 _____ 5-6 _____ 15-16 _____ 6-7 _____ 16-17 _____ 7-8 _____ 17-18 _____ 8-9 _____ 18-19 _____ 9-10 _____
17.	INTERLACE DISPLAY OUT	Trace flickers _____
18.	Increase SWEEP TIME	Observe CRT
19.	PRE-ANALYSIS DELAY 0.5 sec	Trace flicker about twice/second _____
20.	PRE-ANALYSIS DELAY 0.2 sec, 0.1 sec, 50 msec, 20 msec	Flicker rate increases _____
21.	PRE-ANALYSIS DELAY 10 ms, 5 msec	Trace brightens _____
22.	POST-ANALYSIS DELAY	Flicker rate depends on control setting _____
23.	TRIGGER SOURCE to LINE	Flicker rate depends on POST-ANALYSIS DELAY setting.
24.	SWEEP NUMBER counter	N = 0, count = 1 _____
25.	SWEEP NUMBER counter	N = 1, count = _____ N = 2, count = _____ N = 3, count = _____ N = 4, count = _____ N = 5, count = _____ N = 6, count = _____ N = 7, count = _____ N = 8, count = _____ N = 9, count = _____ N = 10, count = _____
26.	Channel B attenuator calibration	.005 V/CM _____
27.	Reverse polarity	Trace moves to bottom of CRT _____
28.	Channel B attenuator calibration	.01 V/CM _____ .02 V/CM _____ .05 V/CM _____
29.	Channel B attenuator calibration	.1 V/CM _____
30.	Channel B SENSITIVITY VERNIER	Max CCW _____

Table 2-2. Incoming Inspection Check Cont'd.

C. TEST RECORD Cont'd.		
31.	Channel B attenuator calibration	.2 V/CM _____ .5 V/CM _____ 1 V/CM _____ 2 V/CM _____ 5 V/CM _____ 10 V/CM _____ 20 V/CM _____
32.	Channel A attenuator calibration	.005 V/CM _____
	Reverse polarity	Trace moves to bottom of CRT _____
	Channel A attenuator calibration	.01 V/CM _____ .02 V/CM _____ .05 V/CM _____ .1 V/CM _____
	Channel A SENSITIVITY	Max CCW _____
	Channel A attenuator calibration	.2 V/CM _____ .5 V/CM _____ 1 V/CM _____ 2 V/CM _____ 5 V/CM _____ 10 V/CM _____ 20 V/CM _____
33.	PRE-ANALYSIS DELAY	20 μ sec _____ 50 μ sec _____ .1 msec _____ .2 msec _____ .5 msec _____ 1 msec _____ 2 msec _____
34.	Reverse TRIGGER SOURCE EXTERNAL polarity	Initial phase of displayed sine wave reverses _____
35.	AUTO scaling in SUMMATION mode	Pattern grows, divides by 2, grows, divides, etc. _____
36.	SENSITIVITY MULTIPLIER to 10	Trace is sine wave _____
37.	SENSITIVITY MULTIPLIER to 11-15	Amplitude of sine wave changes by a factor of 2 when switching between following positions 10-11 _____ 11-12 _____ 12-13 _____ 13-14 _____ 14-15 _____
38.	Channel A DISPLAY to INPUT	Trace flickers _____
39.	Channel A DISPLAY to NOISE	Trace flickers _____
40.	Change SWEEP TIME to 10 msec	Flicker rate is half that of steps 38 and 39 _____

Table 2-2. Incoming Inspection Check Cont'd.

C. TEST RECORD Cont'd.		
41.	Memory overload in AVERAGE	Display is clipped sine wave with no "rain" _____
42.	Connect oscilloscope	
43.	POS SYNCH OUTPUT	Amplitude _____ Width at base _____ Baseline _____
44.	NEG SYNCH OUTPUT	Amplitude _____ Width at base _____ Baseline _____
45.	SAMPLE OUTPUT	Amplitude _____ Width at base _____ Baseline _____
46.	Z AXIS OUTPUT	Amplitude _____ Width at base _____ Baseline _____
47.	PEN LIFT CONTROL	Amplitude _____ Width at base _____ Baseline _____
48.	POINT PLOTTER SEEK	Amplitude _____ Width at base _____ Baseline _____
49.	POINT PLOTTER PLOT	Dot on CRT _____ PROCESS STOP lights _____
50.	SAMPLE INPUT	Dot on CRT _____
51.	MCS INPUT	Two-step waveform _____
52.	External oscilloscope	VERTICAL DAC _____ HORIZ DAC _____ Z AXIS _____
53.	External oscilloscope	VERTICAL SCOPE OUTPUT _____
54.	TIME HISTOGRAM	Dot 2.5 cm from left side of trace _____
55.	FREQUENCY HISTOGRAM	Dot 0.2 cm from left side of trace _____
56.	SWEEP VOLTAGE OUTPUT	Ramp height _____ Ramp linearity _____

SECTION III OPERATION

3-1. BASIC CONCEPT

3-2. The similarity of the 5480A Signal Analyzer System to a standard oscilloscope is apparent from some of the control names (POSITION, TRIGGER SOURCE/LEVEL, SENSITIVITY V/CM, SWEEP TIME). The 5480A is basically an oscilloscope for looking at noisy signals, and can provide up to 60 dB of improvement in signal-to-noise ratio. Further descriptions of the Signal Analyzer system are given in Figure 3-3 thru 3-5. Operating instructions for each mode are given in Figures 3-6 thru 3-10. Special operating instructions (for increasing frequency range, use with auxiliary equipment, etc, are given in Figures 2-2 and 2-3).

3-3. Figure 3-1 enables estimation of experiment length from the time PROCESS START button is pressed, until OUTPUT DISPLAY pushbutton lights at end of experiment. The chart does not include any allowance for 5480A "dead time", so actual experiment length may be up to 100 per cent longer than estimated. Any PRE-ANALYSIS DELAY or POST-ANALYSIS DELAY should be added to SWEEP TIME line and included in overall experiment length.

Figure 3-1. Time to PRESET (Nomograph)

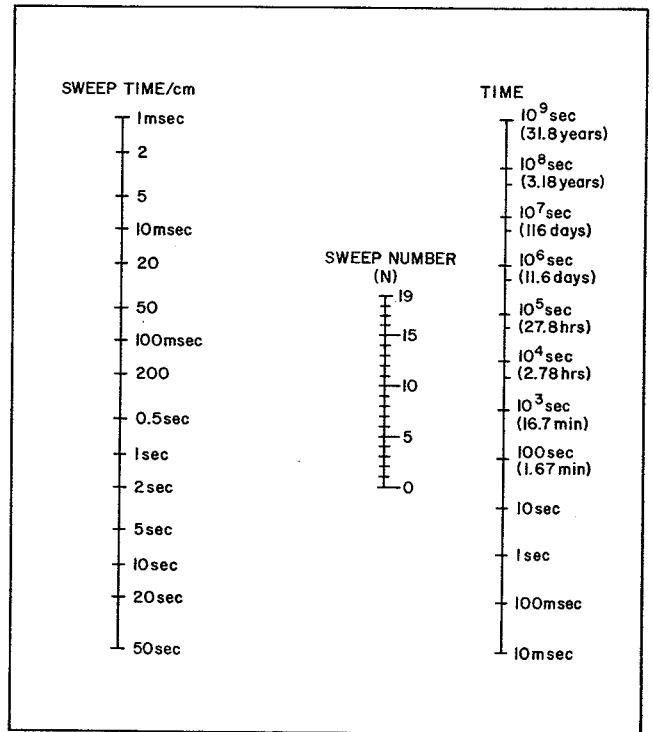

Figure 3-2. Pre-Analysis and Post-Analysis Delays

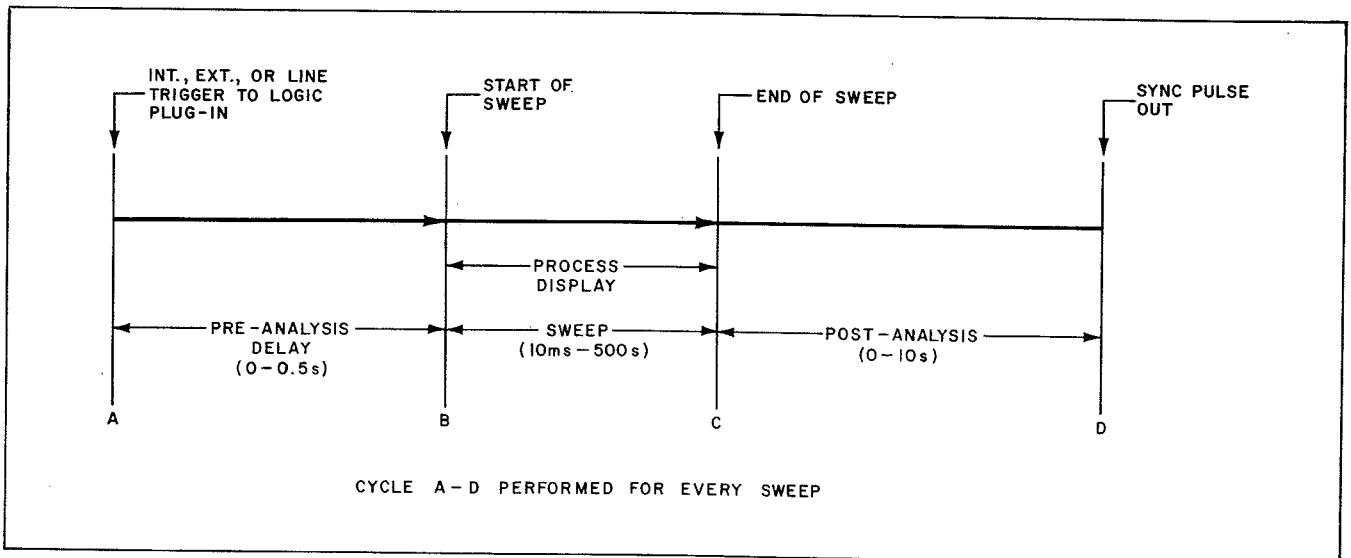
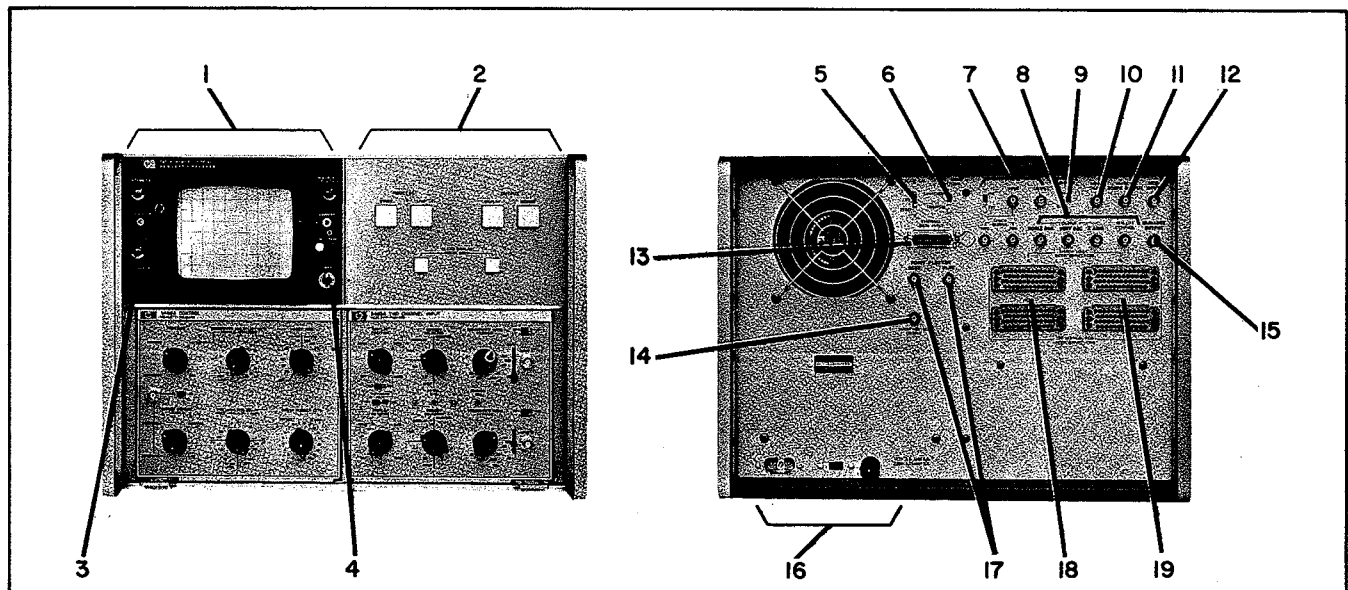

Figure 3-3. Memory-Display Unit (5480A)



DESCRIPTION: Provides memory, logic, power supply and display output for Signal Analyzer System.

CONTROLS, CONNECTORS, INDICATORS:

FRONT PANEL:

1. DISPLAY:

CRT: Provides visual output from 5480A. See Figures 3-7 thru 3-10 for interpretation of display.

INTENSITY: Adjusts CRT trace intensity. Prevent CRT phosphor burns by keeping intensity as low as possible while maintaining good trace visibility.

TRACE ALIGN: Rotates trace for alignment with graticule.

FOCUS: Adjusts CRT focus. Set for smallest spot size.

MAGNIFIER: Expands horizontal display scale by factor of 5 (in X5) to provide increased resolution.

2. MEMORY

PROCESS and OUTPUT controls are pushbutton switches containing indicator lamps. Lighted button indicates Memory activity in progress.

PROCESS START: Enables signal processing by Memory. Processing begins at first sync pulse after pushbutton is pressed. If pressed while STOP or DISPLAY button is lighted, processing resumes at next sync pulse. Button remains lighted during signal processing.

PROCESS STOP: Stops signal processing by Memory. No CRT display.

OUTPUT DISPLAY: Causes Memory contents to be displayed on CRT. Stops signal processing if pressed while START button is lighted.

OUTPUT RECORD: When signal processing is stopped, causes 5480A to step through Memory contents once at rate selected by SWEEP TIME control. Memory contents are provided in analog form at rear panel OUTPUT connectors (item 8). Output signal can be recorded by X-Y recorder at rate which recorder pen can follow. (A PEN LIFT signal is also provided at rear panel.)

CLEAR DISPLAY: Two pushbutton switches must be pressed simultaneously to erase Memory contents being displayed on CRT. Use of two buttons prevents accidental erasure of Memory contents.

3. CALIBRATOR: Female banana connector. One-volt peak-to-peak square wave. Output frequency depends on SWEEP TIME to maintain the same number of cycles on CRT display regardless of SWEEP TIME.

4. POWER

Switch controls ac power to 5480A.

White ON lamp lights whenever ac power is applied.

Red RESET lamp lights to indicate that ac power has been interrupted. Memory contents are protected against ac interruption, but processing cannot continue until the interruption has been acknowledged by resetting the 5480A by turning ac power off for about one second, then on again.

Figure 3-3. Memory-Display Unit (5480A) Cont'd.

REAR PANEL:

5. **SCALE CAL:** Provides means for calibrating an X-Y recorder connected at OUTPUT connectors (item 8). When analog plug-in DISPLAY control is set to DATA, SCALE CAL operates as follows:
 - In FULL, a dot appears at upper right corner of CRT.
 - In ZERO, a dot appears at lower left corner of CRT.
 - In OFF, 5480A operates normally.
6. **HORIZ SWEEP WAVEFORM:** Allows operator to select SAWTOOTH or TRIANGLE sweep voltage. In SAWTOOTH, Memory is stepped from 0 (left) to 1000 (right) linearly, jumps back to 0 (left) and steps linearly to 1000 (right) again. In triangle, Memory is stepped from 0 (left) to 1000 (right) linearly, then from 1000 (right) to 0 (left) linearly, then 0 (left) to 1000 (right), etc.

SAWTOOTH gives continual left-to-right sweeps while TRIANGLE gives alternate left-to-right and right-to-left sweeps (steps through Memory).
7. **SAMPLE:**

INT/EXT Switch: In INT, 5480A uses internal 100 kHz time base to establish sampling rate. In EXT, 5480A uses signal applied at SAMPLE INPUT connector to establish sampling rate.

SAMPLE OUTPUT connector. Female BNC. One-thousand logic level sample pulses per sweep. Output available from either internal or external sweeps.

SAMPLE INPUT connector. Female BNC. Signal applied here establishes sampling rate when INT/EXT switch set to EXT. Signal frequency must be less than 20 kHz and levels must vary from 0V or more negative to +2V or more positive.
8. **OUTPUT:** Female BNC connectors. Provides necessary analog outputs for driving X-Y recorder, point plotter, oscilloscope, or other analog device.

HORIZ DAC provides 0V to +10V ramp, proportional to each Memory address.

VERT DAC provides -5V to +5V, proportional to vertical display.

Z AXIS provides 2V logic-level signal for oscilloscope blanking.

PEN LIFT CONTROL provides logic level signal to drop X-Y recorder pen at start of sweep and lift pen at end of sweep.
9. **INTERLACE DISPLAY:** Controls display sweep.

When set to IN, display address register sweeps memory and CRT continuously at 1 msec/cm, providing continuous flicker-free display, regardless of Logic Plug-in SWEEP TIME setting.

When SWEEP VOLTAGE OUTPUT (item 14) is being used, set INTERLACE DISPLAY to OUT. This will make SWEEP VOLTAGE OUTPUT a single ramp for each triggering sync pulse.
10. **NOISE OUTPUT:** Female BNC connector. Provides noise being removed from data signal. Voltage level is correct for that point during time CRT is unblanked (Z AXIS OUTPUT pulse).
11. **VERT SCOPE OUTPUT:** Female BNC connector. Provides -5V to +5V ac signal (proportional to amplitude of displayed signal) riding on a dc offset voltage that is proportional to setting of Analog Plug-in Vertical POSITION control.
12. **MCS INPUT:** Female BNC connector. Signal input for MCS (multichannel scaling) made (see Figure 3-10).
13. **EXTERNAL DATA INPUT:** 24-pin connector. Inputs parallel data inputs from Analog Plug-in connector.
14. **SWEEP VOLTAGE OUTPUT:** Female BNC connector. Provides sawtooth (0V to +1V) signal synchronized with analyzer sweep. Set INTERLACE DISPLAY to OUT when using this connector.
15. **VARIANCE OUTPUT:** Female BNC connector. Provides square of noise only (variance of input signal) when variance option is installed. By observing this output on an unused 5480A input channel, operator can tell if average waveform is made up of more than one input signal locked to the input sync frequency.
16. **POWER**

Connector accepts flat-connector end of HP Part No. 8120-0078 power cord.

115/230 slide switch allows operation from either 115V or 230V ac lines. Use a narrow-blade screwdriver to slide switch so numbers indicating operating line voltage are exposed. Be sure correct fuse is installed: For 115V, use 2.5A slow-blow, HP Part No. 2110-0015. For 230V, use 1.25A slow-blow, HP Part No. 2110-0021.
17. **POINT PLOTTER:** Female BNC connectors.

SEEK supplies signal telling point plotter to plot a point.

PLOT receives signal from plotter, indicating point has been plotted.

Point plotter X and Y inputs come from HORIZ DAC and VERT DAC OUTPUTs, respectively. Logic Plug-in SWEEP TIME switch (see Figure 3-5) must be set to EXT.
18. **SYSTEM LOGIC INTERCONNECTION** for Correlation Synchronizer (not currently available).
19. **SYSTEM LOGIC INTERCONNECTION** for I/O (Input/Output) Coupler, HP Model 5495A. The I/O coupler provides for interface connections between the Model 5480A and computer, teletype, printer, tape reader, or tape punch.

Figure 3-4. Control Plug-in (5486A)

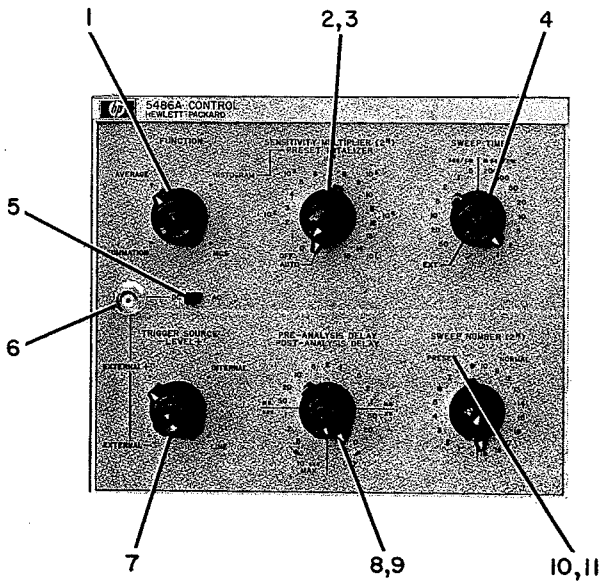

DESCRIPTION: Selects FUNCTION of Signal Analyzer System. Controls system rate, pre- and post-analysis delays, and amount of processing for each analysis.

CONTROLS, CONNECTORS:

1. FUNCTION:

SUMMATION: Causes successive repetitions of input signal to be added, keeping a "running total". Vertical display is not calibrated (see Figure 3-8).

AVERAGE: Keeps "calibrated average" of successive input signal repetitions. Provides continuous calibrated display (see Figure 3-7).

HISTOGRAM: Creates plot of number-of-occurrences (probability) on vertical axis versus frequency or period on horizontal axis. Input signal is applied at input connector (item 6).

MCS: Creates plot of frequency on vertical axis versus time on horizontal axis. Input signal is applied through MCS INPUT connector (item 12, Figure 3-3).

N	2^N
0	1
1	2
2	4
3	8
4	16
5	32
6	64
7	128
8	256
9	512
10	1024
11	2048
12	4096
13	8192
14	16384
15	32768
16	65536
17	131072
18	262144
19	524288

2. SENSITIVITY MULTIPLIER (2^N): Multiplies vertical display size by 2^N . Dial is calibrated in N, thus as control is turned clock-wise each position doubles display size. In AUTO, vertical display is automatically calibrated in terms of V/cm on the input attenuator setting when signal was being processed.

3. PRESET TOTALIZER. When FUNCTION set to HISTOGRAM, specifies total number of samples to be histogrammed. In OFF, histograms continue until manually stopped by pressing OUTPUT DISPLAY or PROCESS STOP pushbutton.

4. SWEEP TIME: Determines rate at which address register steps through Memory, (processing rate). In EXT, input signal connected through SAMPLE INPUT connector (see item 7, Figure 3-3) is converted to a train of sampling pulses; nearly any periodic waveform may be used for this application.

In Frequency HISTOGRAM mode, SWEEP TIME control calibrates Horizontal axis (Figure 3-9).

Figure 3-4. Control Plug-in (5486A) Cont'd.

5. AC/DC: Selects ac coupling or dc coupling of input sync signals in SUMMATION and AVERAGE mode.
6. Input connector: Female BNC. Sync input for SUMMATION and AVERAGE mode; signal input for HISTOGRAM mode. See Figure 3-7 through Figure 3-10.
7. TRIGGER SOURCE/LEVEL: Operates in SUMMATION, AVERAGE, and HISTOGRAM modes only.
- TRIGGER SOURCE selects triggering signal from: INTERNAL, uses sync signal generated at end of each sweep (5480A is free-running). LINE, uses signal derived from power line frequency. EXTERNAL + or -, uses signal at BNC connector (item 6); derives sync pulse from positive or negative signal slope.
8. PRE-ANALYSIS DELAY: Provides calibrated 20 μ sec to 0.5 sec delay between input sync signal and start of sweep. Conserves memory and increases resolution by eliminating unnecessary front portion of data waveform display (see Figure 3-2).
9. POST-ANALYSIS DELAY: Provides uncalibrated zero to 10 second delay of output sync pulse occurring at end of every sweep. If this sync output is used to start each repetition of an experiment, start of experiment will be delayed by this amount (see Figure 3-2).
10. SWEEP NUMBER (2^N): Selects number of sweeps or repetitions to be averaged. Dial is calibrated in N, number of sweeps is 2^N (for example, SWEEP NUMBER 3 causes 8 sweeps to be averaged). Signal-to-noise ratio improvement in dB is approximately 3N. For example, where N is 3, dB improvement is 9 dB.
11. PRESET/NORMAL:
- PRESET (AVERAGE): 5480A averages number of sweeps selected by SWEEP NUMBER, stops and DISPLAYs result (see Figure 3-7). This is stable averaging.*
- NORMAL (AVERAGE): 5480A averages number of sweeps selected by SWEEP NUMBER, and continues averaging with this number of sweeps defining the weighting time constant until stopped manually. This is weighted averaging. (See Figure 3-7.)
- PRESET (SUMMATION): 5480A adds number of sweeps selected by SWEEP NUMBER control, stops and DISPLAYs result (see Figure 3-8).*
- NORMAL (SUMMATION): 5480A adds inputs until manually stopped (see Figure 3-8). The AUTO scaling feature of SENSITIVITY MULTIPLIER ceases operation in NORMAL mode during SUMMATION after SWEEP NUMBER has been reached.
- * NOTE: In PRESET (AVERAGE) or PRESET (SUMMATION), and SWEEP NUMBER is 19, 5480A will stop and DISPLAY result after 2^{18} sweeps.

Figure 3-5. Two Channel Input Plug-in (5485A)

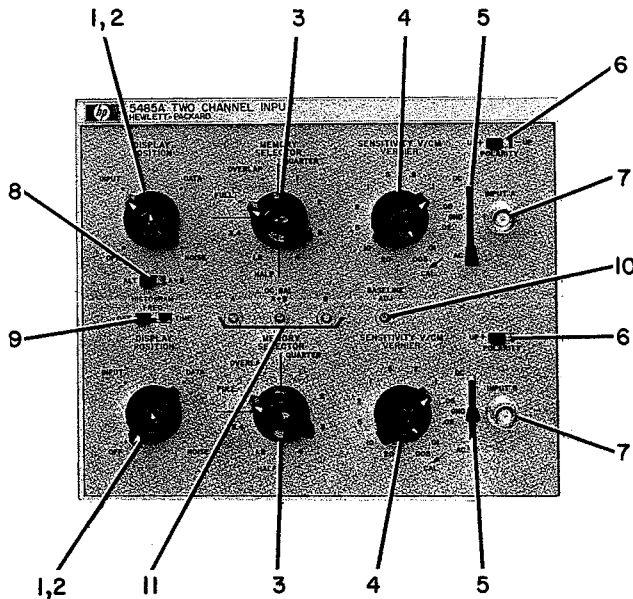

DESCRIPTION: Accepts one or two channels of input data to be presented as vertical portion of Signal Analyzer display.

CONTROLS, CONNECTORS:

1. **DISPLAY:** Selects CRT display for its channel. INPUT displays raw, unprocessed input signal. DATA displays averaged signal, MCS, or histogram. NOISE displays difference between INPUT and averaged signal. OFF turns channel off (see item 3).
2. **POSITION:** Adjusts vertical position of its channel on CRT display.
3. **MEMORY SELECTOR:** Selects portion of Memory to be used for storage, display, or processing. Memory is divided into four quarters. Operator may select memory portions for either channel as follows:
 QUARTER 1
 QUARTER 2
 QUARTER 3
 QUARTER 4
 HALF (QUARTERS 1 and 2)
 HALF (QUARTERS 3 and 4)
 FULL (QUARTERS 1, 2, 3, and 4)

In OVERLAP all four quarter sections are displayed simultaneously as separate traces.

When MEMORY SELECTOR controls are set to cause both channels to be connected to same Memory quarter, A rules. For example, if MEMORY SELECTOR A is set to FULL, no quarter is left for B; or, if MEMORY SELECTOR A is set to QUARTER 1, and MEMORY SELECTOR B set to FULL, Channel A gets QUARTER 1, and Channel B gets QUARTERS 2, 3, and 4.

4. **SENSITIVITY/VERNIER:**

SENSITIVITY: Attenuates input signal and provides calibration of vertical display axis from 5 mV/cm to 20 V/cm.

VERNIER: Provides continuous, uncalibrated attenuation of vertical display axis. Does not affect input signal amplitude stored in memory.

5. **DC/GND/AC:** Switches from dc coupling, grounding, or ac coupling of input. In GND, input connector is open-circuited, and input to amplifier is grounded to provide a zero reference.

6. **UP+/-UP:** Inverts input signal, allowing waveform to be displayed with positive voltage above baseline (UP+) or below baseline (-UP).

7. **INPUT:** Female BNC connector. Input for AVERAGE or SUMMATION functions (see Figure 3-7 and Figure 3-8).

8. **ALT/A+B:** In ALT, two channels operate separately. In A + B, signal at INPUT B is added to signal at INPUT A and sum is fed through Channel A only. Difference between two signals can be averaged by setting one channel to UP+ and other to -UP.

9. **HISTOGRAM FREQ/TIME:** If Logic Plug-in FUNCTION is set to HISTOGRAM, FREQ displays a frequency histogram (use above 1 kHz), or TIME displays a period (time) histogram (use below 1 kHz). See Figure 3-9.

10. **BASELINE ADJ:** Adjusts baseline to prevent baseline drift during summation.

11. **DC BAL controls:** Compensates for small dc offsets in the input circuits so dc input will be stored as "0" in the memory.

Figure 3-6. Setup and Turn-on

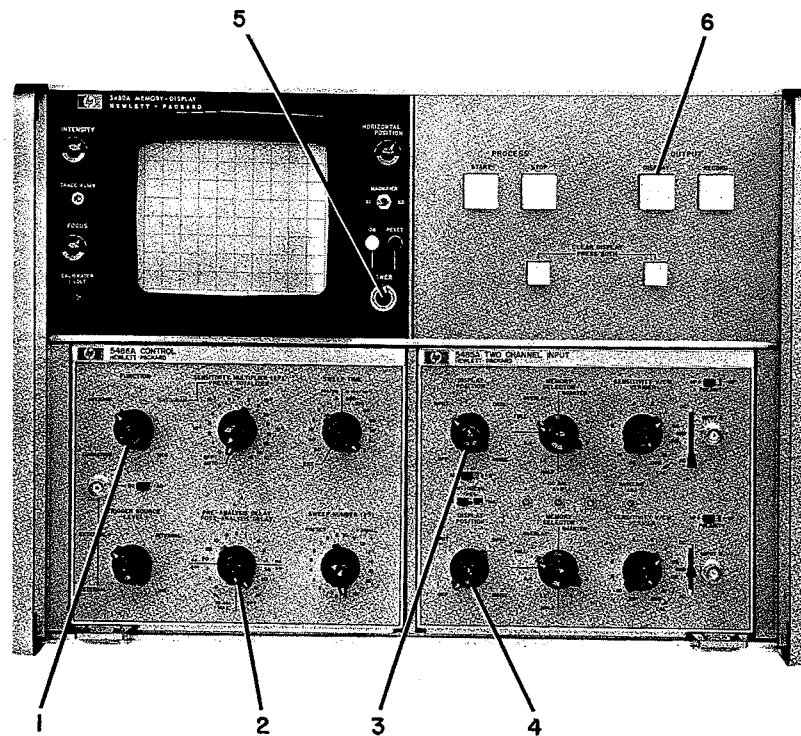
**SETUP:**

Connect input signals and any auxiliary equipment to Signal Analyzer System. Input/output signal specifications and typical setups are given in Section II.

Set 115/230-volt slide switch (see item 16, Figure 3-3) so numbers indicating line voltage to be used are exposed. Install correct fuse for this line voltage (use 2.5A slow-blow for 115V; 1.25A slow-blow for 230V).

Connect Signal Analyzer to ac line.

NOTE: Operating instructions and indications below are for standard Signal Analyzer Systems with no auxiliary equipment connected to J15, J16, J17, or J18. Operating instructions for systems with connections to these connectors are contained in manuals for the auxiliary equipment.

Set controls as listed below:

1. FUNCTION to AVERAGE.
2. PRE-ANALYSIS DELAY and POST-ANALYSIS DELAY to "0" and OFF, respectively.
3. Channel A DISPLAY to DATA.
4. Channel B DISPLAY to OFF.

TURN-ON:

5. Turn on ac power. POWER switch (item 5) is near lower right corner of CRT. At turn-on, the white ON and PROCESS STOP switch lamps will light. There will be no CRT display.
6. Press OUTPUT DISPLAY pushbutton. Button will light, and display appear on CRT. Observe CRT display for each of the following Channel A DISPLAY switch positions: FULL; HALF 3, 4; HALF 1, 2; QUARTER 1; QUARTER 2; QUARTER 3, QUARTER 4. Display for each setting represents what was in that portion of memory when Signal Analyzer was turned off. If memory section being displayed is not important, erase it by pressing both CLEAR DISPLAY pushbuttons simultaneously; and quarter or half of the memory can be erased independently of other memory sections.

SELECT OPERATING MODE:

Operating mode is selected by FUNCTION switch (item 1). AVERAGE (see Figure 3-7), SUMMATION (see Figure 3-8), HISTOGRAM (see Figure 3-9), and MULTICHANNEL SCALING (MCS) (see Figure 3-10).

Figure 3-7. Average

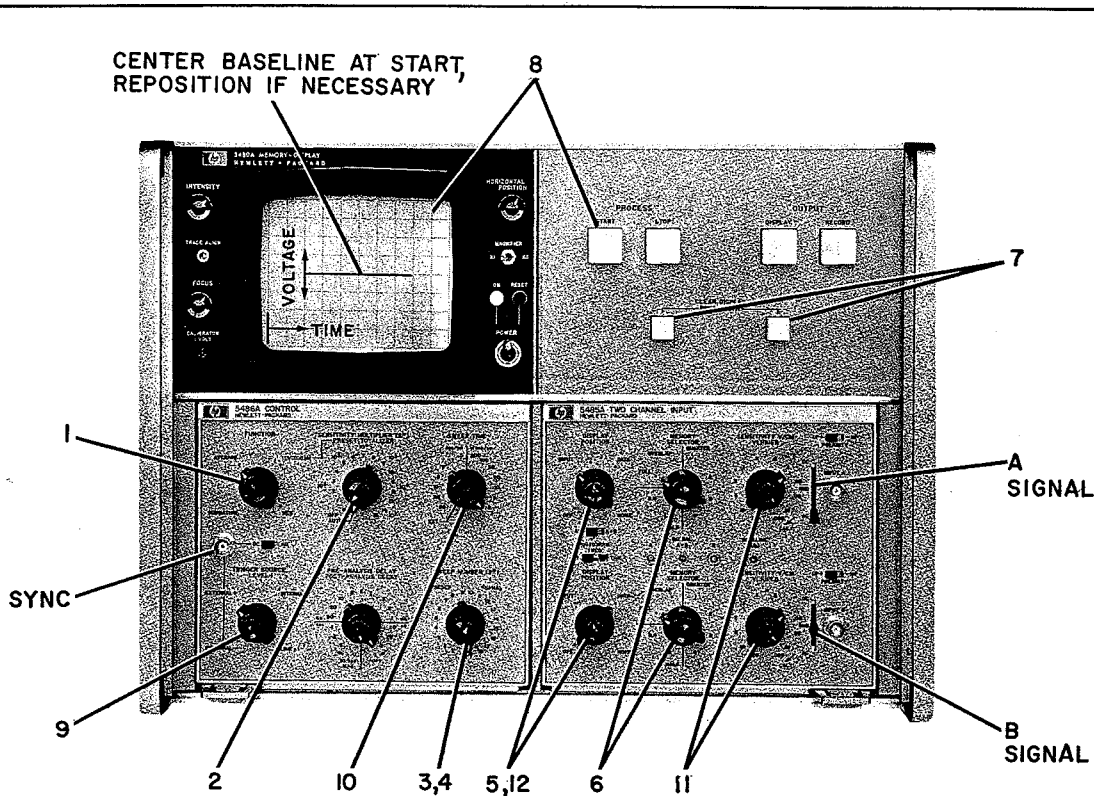

DESCRIPTION: Analyzer performs either weighted or calibrated average. Display resembles oscilloscope presentation of input signal, with noise averaged out. Up to 60 dB of signal-to-noise ratio improvement can be obtained. Vertical display is calibrated in V/cm, noisy signal appears at full value and noise is gradually removed, leaving only signal.

Perform SETUP and TURN-ON procedure described in Figure 3-6.

CONTROL SETTINGS

1. FUNCTION to AVERAGE.
2. SENSITIVITY MULTIPLIER fully CCW.
3. SWEEP NUMBER to about 6.
4. PRESET/NORMAL to NORMAL.
5. Channel A and Channel B DISPLAY to DATA (or OFF, if Channel is not used).
6. Channel A and Channel B MEMORY SELECTOR. As desired.
 - a. Larger memory sections provide more signal resolution.
 - b. A processed signal can be stored in one memory section while processing is done in another section.

- c. If MEMORY SELECTOR controls are set to feed A and B to same quarter section of memory, A overcomes B.
- d. Signal processing occurs only
 - 1) In memory sections selected by MEMORY SELECTOR switches,
 - 2) when PROCESS START button is lighted,
 - 3) and sync signal is received by Logic plug-in.

7. Clear display by simultaneously pressing both CLEAR DISPLAY buttons. OUTPUT DISPLAY button will light, and CRT will display a horizontal line.
8. Press PROCESS START pushbutton. Button will light, and OUTPUT DISPLAY light will go out. Display will show signal processing.
9. If necessary, select TRIGGER SOURCE and adjust LEVEL to initiate processing. Ordinarily, best triggering is obtained using an external triggering source having the same frequency as noisy signal to be observed.
10. Adjust SWEEP TIME for best display of input signal. Press both CLEAR DISPLAY buttons and PROCESS START button each time SWEEP TIME is changed.

Figure 3-7. Average Cont'd.

11. Adjust VERTICAL SENSITIVITY for each displayed input channel to provide best CRT display of input signal.
12. Use POSITION controls to separate or center signals vertically.

The above procedure provides a means for obtaining a rough measurement of signal amplitude and frequency, and positioning display. Information below enables refinement of measurement.

SIGNAL-TO-NOISE RATIO IMPROVEMENT VS RESPONSE TO INPUT SIGNAL CHANGES

Signal-to-noise ratio improvement can be determined approximately by SWEEP NUMBER setting, and can be expressed in dB as 3N, where N is SWEEP NUMBER. For example, where N is 10, signal-to-noise ratio improvement is 30 dB (after 2^N, or 1024 sweeps).

Higher SWEEP NUMBER settings result in greater signal-to-noise ratio improvement.

Lower SWEEP NUMBER settings enable faster response to input signal changes or changes in Signal Analyzer control settings when PRESET/NORMAL switch is on NORMAL.

NOTE: To prevent invalid readings, the following SWEEP NUMBER and SWEEP TIME combinations should not be used:

SWEEP TIME	SWEEP NUMBER
1 msec/cm	19 (PRESET) see NOTE under NORMAL VS PRESET
2 msec/cm	19, 18
5 msec/cm or slower	19, 18, 17, 16

This SWEEP NUMBER limitation (except 1 msec/cm) is directly related to the 5-, 7-, or 9-bit resolution of the Analog-to-Digital Converter (depending on SWEEP TIME). If input signals are so noisy that 2¹⁵ sweeps are not sufficient (2¹⁷ sweeps at 2 msec/cm), the modification below may be made to the 5485A Dual Channel Input plug-in; the modification restricts resolution to 5 bits for all SWEEP TIMES.

Modification to 5485A for decreased resolution:

1. Remove connecting wires from XA3(2) and XA3(3).
2. Tape ends of wires removed in step 1.
3. Ground pins XA3(2) and XA3(3) by connecting them to XA3(17).

NORMAL VS PRESET

NORMAL: Signal Analyzer averages all sweeps until it completes 2^N sweeps. After this number of sweeps is completed, averaging process continues, except that previous information is weighted exponentially with a time constant equal to the time required to take 2^N sweeps. Averaging continues until PROCESS STOP (no CRT display) or OUTPUT DISPLAY push-button is pressed.

PRESET: Signal Analyzer averages all sweeps until it completes 2^N sweeps. * After this number of sweeps is completed, averaging process stops and Analyzer automatically switches to OUTPUT DISPLAY. Note that the value of 2^N increases very rapidly (see table in Figure 3-5), and large values of 2^N can result in very long experiment times. A nomograph (Figure 3-1) is provided to enable approximations of experiment length from PROCESS START to OUTPUT DISPLAY. As with NORMAL, averaging process can be stopped at any time by pressing PROCESS STOP or OUTPUT DISPLAY button.

CRT DISPLAY

Signal is displayed full-scale and noise is reduced with each sweep.

Vertical calibration for displayed channel is determined by SENSITIVITY V/CM control.

Horizontal calibration is determined by SWEEP TIME and X1/X5 switch.

In OUTPUT DISPLAY, vertical display can be expanded by changing setting of SENSITIVITY MULTIPLIER.

VERNIER of displayed channel provides for uncalibrated reduction in display size (does not affect input SENSITIVITY).

For PRE-ANALYSIS DELAY and POST-ANALYSIS DELAY information, see Figure 3-2.

*NOTE: Except for N = 19. In PRESET, N = 19 and N = 18 are same, 5480A sweeps for 2¹⁸ sweeps, then DISPLAYs result.

Figure 3-8. Summation

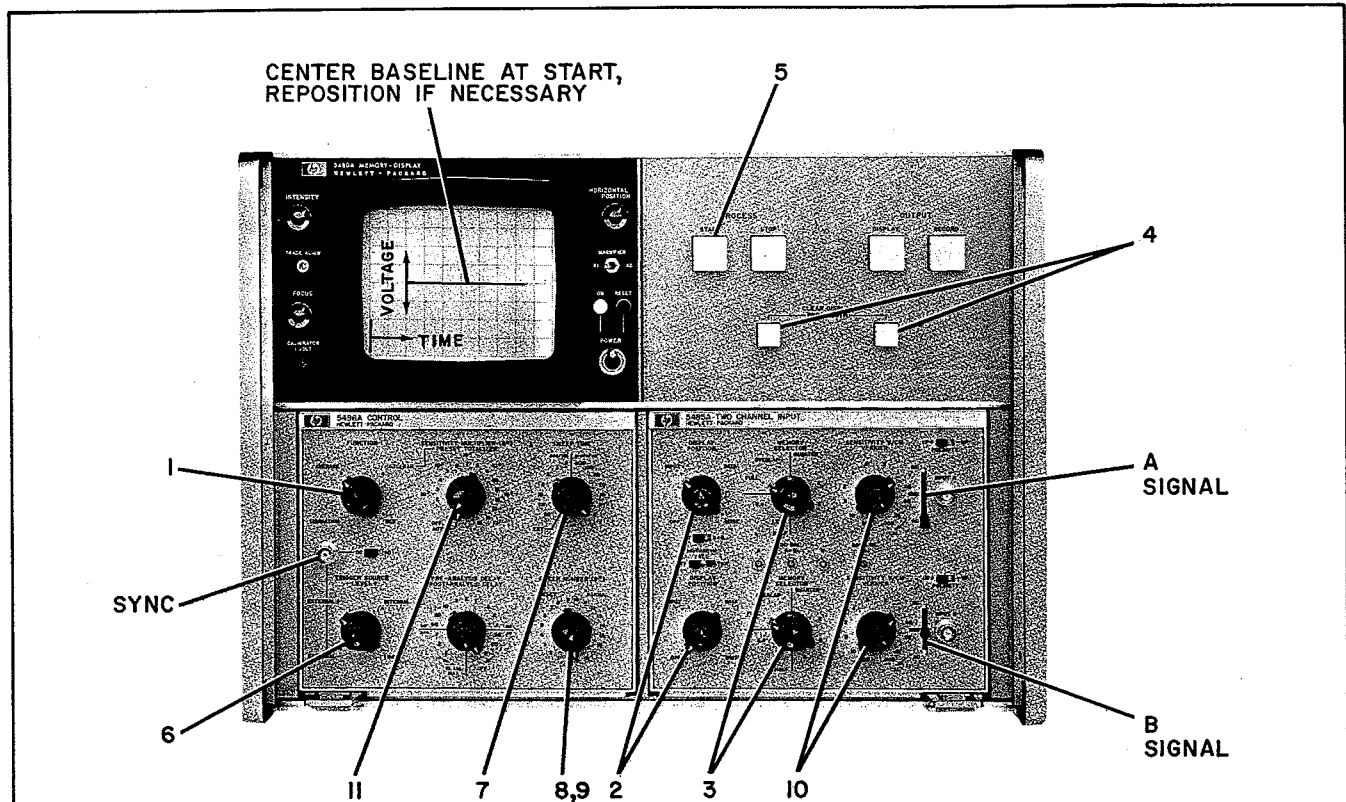

DESCRIPTION: Analyzer adds successive repetitions of noisy input waveform, resulting in an uncalibrated display which is proportional to averaged signal. Display resembles oscilloscope presentation of input signal, growing with each successive sweep; display can be halved automatically when it reaches some predetermined size, to keep it on screen.

Perform **SETUP** and **TURN-ON** procedure described in Figure 3-6.

CONTROL SETTINGS

1. **FUNCTION** to **SUMMATION**.
2. Channel A and Channel B **DISPLAY** to **DATA** (or to **OFF**, if channel is not used).
3. Channel A and Channel B **MEMORY SELECTOR**. As desired.
 - a. Larger memory sections provide more signal resolution.
 - b. A processed signal can be stored in one memory section while processing is done in another section.
 - c. If **MEMORY SELECTOR** controls are set to feed A and B to same quarter section of memory, A overcomes B.

- d. Signal processing only occurs:
 - 1) In memory sections selected by **MEMORY SELECTORS**.
 - 2) When **PROCESS START** button is lighted.
 - 3) When sync signal is received by Logic plug-in.

4. Clear display by simultaneously pressing both **CLEAR DISPLAY** buttons. **OUTPUT DISPLAY** button will light, and **CRT** will display a horizontal line.
5. Press **PROCESS START** pushbutton. Button will light, and **OUTPUT DISPLAY** light will go out. Display will show signal processing.
6. If necessary, select **TRIGGER SOURCE** and adjust **LEVEL** to begin processing. Ordinarily, best triggering is obtained using an external triggering source having same frequency as noisy signal to be observed.
7. Adjust **SWEEP TIME** for best display of input signal. Press both **CLEAR DISPLAY** buttons and **PROCESS START** button each time **SWEEP TIME** is changed.
8. **SWEEP NUMBER** to 19.
9. **PRESET/NORMAL** to **PRESET**.

Figure 3-8. Summation Cont'd.

CRT DISPLAY

Signal starts at zero amplitude and grows with each sweep as Signal Analyzer totalizes input sweeps. Rate of vertical presentation growth depends on settings of SENSITIVITY for each displayed channel and SENSITIVITY MULTIPLIER. To keep growing display on-screen, SENSITIVITY MULTIPLIER setting is decreased manually or automatically, as described below.

Vertical display is not calibrated.

Horizontal display is calibrated by SWEEP TIME and X1/X5 settings.

SENSITIVITY MULTIPLIER

Controls vertical display size.

When set to AUTO (and SWEEP NUMBER set to 19):

1. Vertical display is cut in half at end of every 2^N (first, second, fourth, eighth, etc) sweep.
2. Display continues growing at half of previous rate until it is again cut in half.
3. Unless SUMMATION process is stopped (by pressing PROCESS STOP or OUTPUT DISPLAY pushbutton), vertical display is divided in half through the $N = 15$ sweep; after $N = 15$, display keeps growing.

NOTES:

1. SENSITIVITY MULTIPLIER and SWEEP NUMBER switches interact, most noticeably at low SWEEP NUMBER settings. When SENSITIVITY MULTIPLIER is set to AUTO, display is cut in half every 2^N sweeps until N is same number set by SWEEP NUMBER switch. From this time on, no additional AUTO scaling is provided, CRT display grows and must be manually scaled using "N" SENSITIVITY MULTIPLIER SETTINGS.
2. SENSITIVITY MULTIPLIER can be set to any N number from 1 to 15. If setting is changed during a sweep, display size will change at end of that sweep.
3. SENSITIVITY MULTIPLIER can be switched from AUTO to any N number and back to AUTO, and will resume AUTO scaling without loss of count of sweeps.
4. To prevent invalid readings, the following SWEEP NUMBER and SWEEP TIME combinations should

not be used when SENSITIVITY MULTIPLIER is in AUTO:

SWEEP TIME	SWEEP NUMBER
1 msec/cm	19 (PRESET) see NOTE under NORMAL VS PRESET
2 msec/cm	19, 18
5 msec/cm or slower	19, 18, 17, 16

This SWEEP NUMBER limitation (except 1 msec/cm) is directly related to the 5-, 7-, or 9-bit resolution of the Analog-to-Digital Converter (depending on SWEEP TIME). If input signals are so noisy that 2^{15} sweeps are not sufficient (2^{17} sweeps at 2 msec/cm), the modification below may be made to the 5485A Dual Channel Input plug-in; the modification restricts resolution to 5 bits for all SWEEP TIMES.

Modification to 5485A for decreased resolution:

- a. Remove connecting wires from XA3(2) and XA3(3).
 - b. Tape ends of wires removed in step 1.
 - c. Ground pins XA3(2) and XA3(3) by connecting them to XA3(17).
5. If power is lost following summation, and instrument is in DISPLAY, automatic scaling associated with AUTO may be lost and display will not be calibrated. (This happens because the AUTO scaling factor is stored in an active register.) Display calibration can be regained, however, by setting SENSITIVITY MULTIPLIER to: $24 - (\text{SWEEP NUMBER} + \text{number of bits})$.
- number of bits = 5 in 1 msec/cm SWEEP TIME
 = 7 in 2 msec/cm SWEEP TIME
 = 9 in 5 msec/cm or slower SWEEP TIMES.

EXAMPLE: SWEEP NUMBER is 6, SWEEP TIME is 10 msec/cm. Set SENSITIVITY MULTIPLIER to $24 - (6 + 9)$ or 9.

NORMAL VS PRESET

NORMAL: Set SWEEP NUMBER to 19. Analyzer totalizes until manually stopped by pressing PROCESS STOP or OUTPUT DISPLAY pushbutton. AUTO scaling feature of SENSITIVITY MULTIPLIER ceases operation in NORMAL mode during SUMMATION after SWEEP NUMBER has been reached.

PRESET: Set SWEEP NUMBER to number of sweeps to be totalized. Signal Analyzer will totalize this number of sweeps*, stop processing, and display result.

*NOTE: Except for $N = 19$. In PRESET, $N = 19$ and $N = 18$ are same, 5480A sweeps for 2^{18} sweeps, then DISPLAYs result.

Figure 3-9. Histograms

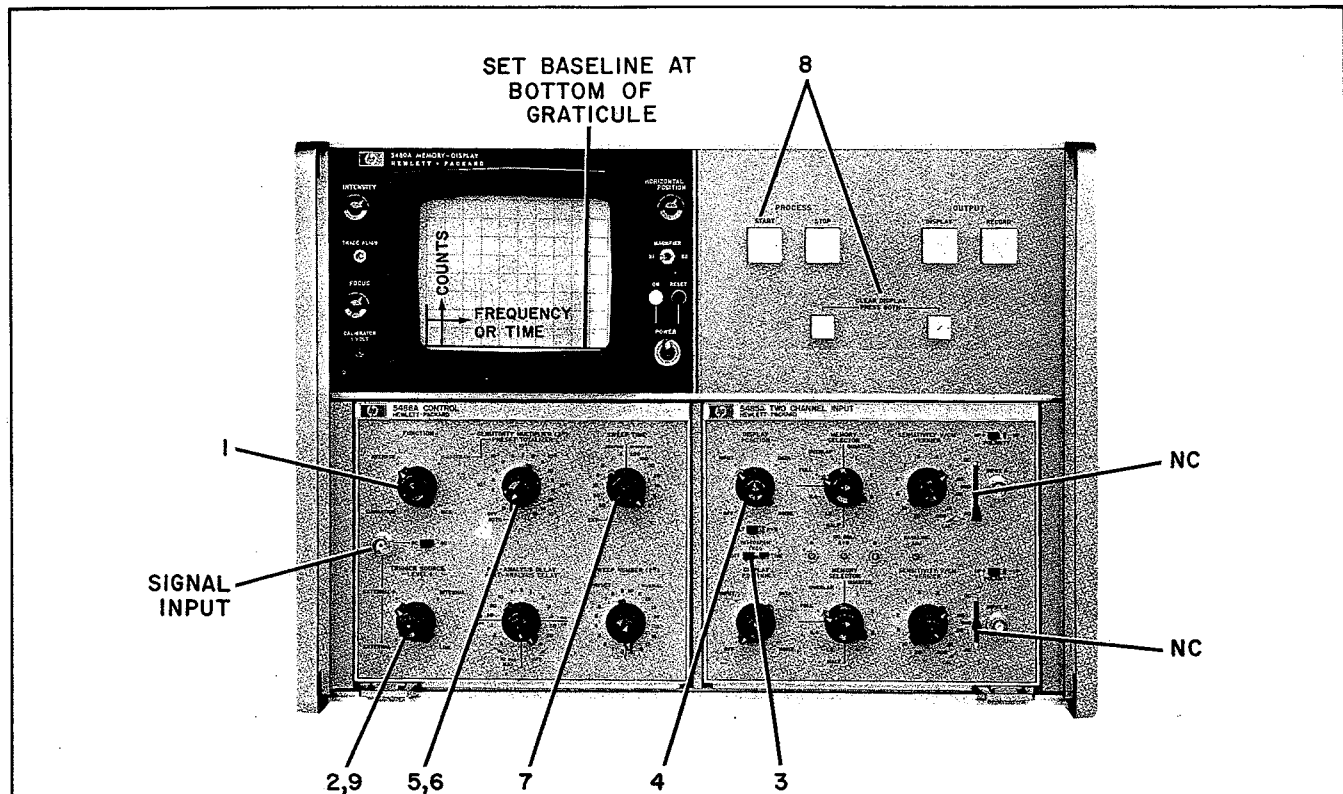

DESCRIPTION: Analyzer displays a probability-versus-frequency (or time interval) plot. Number of incoming pulses during a set gate time determines memory location into which a count is placed. After several gate times, a distribution results.

Perform **SETUP** and **TURN-ON** procedure described in Figure 3-6.

CONTROL SETTINGS

1. **FUNCTION** to HISTOGRAM
2. **TRIGGER SOURCE** to either **EXTERNAL** position
3. **HISTOGRAM** to:
FREQ for input signals between 1 kHz and 1 MHz
TIME for input signals below 1 kHz
4. Channel A **DISPLAY** to DATA
5. **SENSITIVITY MULTIPLIER** to 15
6. **PRESET TOTALIZER** to OFF, or to number of events to be accumulated.
7. **SWEEP TIME** to 1 msec/cm
8. Press both **CLEAR DISPLAY** buttons, then **PROCESS START**.
9. Adjust **TRIGGER LEVEL**, if necessary, to enable triggering.

CRT DISPLAY

SWEEP TIME may be adjusted for best display.

Horizontal baseline calibration is as follows:

For **TIME HISTOGRAMS**, read calibration directly from **SWEEP TIME** setting.

For **FREQ HISTOGRAMS**, convert **SWEEP TIME** to frequency/cm, using chart below:

SWEEP TIME Setting	Display Calibration	Max Input Frequency	Usable Horiz Range
1 msec/cm	10 MHz/cm	1 MHz	0.1 cm
2 msec/cm	5 MHz/cm	1 MHz	0.2 cm
5 msec/cm	2 MHz/cm	1 MHz	0.5 cm
10 msec/cm	1 MHz/cm	1 MHz	1.0 cm
20 msec/cm	500 kHz/cm	1 MHz	2.0 cm
50 msec/cm	200 kHz/cm	1 MHz	5.0 cm
100 msec/cm	100 kHz/cm	1 MHz	10.0 cm
200 msec/cm	50 kHz/cm	500 kHz*	10.0 cm
.5 sec/cm	20 kHz/cm	200 kHz*	10.0 cm
1 sec/cm	10 kHz/cm	100 kHz*	10.0 cm
2 sec/cm	5 kHz/cm	50 kHz*	10.0 cm
5 sec/cm	2 kHz/cm	20 kHz*	10.0 cm
10 sec/cm	1 kHz/cm**	10 kHz*	10.0 cm

* Maximum frequency that can be displayed.

** For frequencies below 1 kHz, use **TIME HISTOGRAM** mode.

Figure 3-10. MCS (Multichannel Scaling)

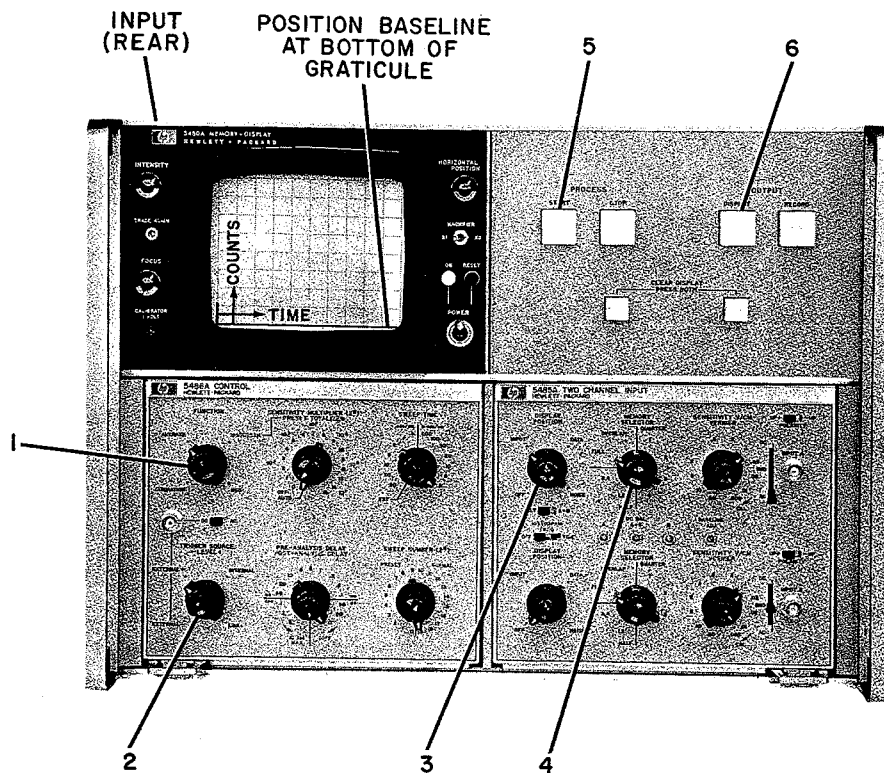

DESCRIPTION: Analyzer displays a plot of frequency-versus-time. Analyzer sweeps through its memory, remaining at each location for a set gate time. Number of counts placed in each location is determined by number of input pulses during gate time for that location.

Perform **SETUP** and **TURN-ON** procedure described in Figure 3-6.

CONTROL SETTINGS

1. **FUNCTION** to **MCS**
2. **TRIGGER SOURCE** to **INTERNAL**
3. **Channel A DISPLAY** to **DATA**. There is no Channel B display.
4. **Channel A MEMORY SELECTOR** to **FULL**.
5. Press **PROCESS START** button.
6. After about 10 seconds press **OUTPUT DISPLAY** button.

CRT DISPLAY

During MCS processing, CRT display is only a dot moving across screen at rate determined by **SWEEP TIME** control. When **OUTPUT DISPLAY** is pressed, display will appear.

Display represents number of counts received at each horizontal position as memory is stepped through all 1000 positions. This represents a "window" between 10 msec and 500 sec (8.34 min) wide, determined by **SWEEP TIME** setting.

If MCS display is not satisfactory, try a different **SWEEP TIME** setting. Be sure to clear display when changing **SWEEP TIMES**.

Vertical display is not calibrated.

Horizontal display is calibrated by **SWEEP TIME**. Either the **HORIZ DAC** or **SWEEP OUTPUT** voltage (available at rear-panel connectors) may be used to control MCS input source, to relate input signal frequency to horizontal channel being scaled, instead of the more usual time variation.

SECTION IV MAINTENANCE

4-1. SCHEDULING

4-2. Preventive maintenance scheduling depends, partly, on the system with which the 5480A Signal Analyzer System is used. The maintenance intervals below are intended to serve as a guide to maintenance scheduling.

- a. DAILY: Operator adjustments (Paragraph 4-5).
- b. MONTHLY: Perform Incoming Inspection Check, Table 2-2. (Time: approximately one hour.)
- c. EVERY THREE MONTHS:
 - 1) Clean all assemblies (see Paragraph 4-12). (Time: approximately one hour.)
 - 2) Perform Incoming Inspection Check, Table 2-2. (Time: approximately one hour.)
- d. EVERY SIX MONTHS:
 - 1) Clean all assemblies (see Paragraph 4-12). (Time: approximately one hour.)
 - 2) Perform complete Calibration and Adjustment procedure (see 5480A Service Manual, Volume I). (Time: approximately two hours.)
 - 3) Perform Incoming Inspection Check, Table 2-2. (Time: approximately one hour.)

4-3. LUBRICATION

4-4. The Models 5480A, 5485A, and 5486A require no lubrication.

4-5. OPERATOR ADJUSTMENTS

4-6. The procedures below should be performed only if necessary. Adjustments are for DC BAL and BASE-LINE of 5485A plug-in.

- 4-7. Set Signal Analyzer controls as follows:
- FUNCTION to AVERAGE
 - TRIGGER SOURCE to INTERNAL
 - PRE-ANALYSIS DELAY to "0"
 - POST-ANALYSIS DELAY to OFF
 - SWEEP NUMBER to "0"
 - PRESET/NORMAL to NORMAL
 - SWEEP TIME to 1 sec/cm
 - SENSITIVITY MULTIPLIER to AUTO
 - PRESET TOTALIZER to OFF
 - MAGNIFIER to X1
 - SCALE CAL to OFF
 - SAMPLE to INT
 - SAWTOOTH/TRIANGLE to SAWTOOTH
 - DISPLAY INTERLACE to IN
 - A DISPLAY to DATA
 - B DISPLAY to DATA

- A MEMORY SELECTOR to FULL
- B MEMORY SELECTOR to FULL
- A+B/ALT to ALT
- HISTOGRAM to OFF
- A SENSITIVITY to .005 V/CM
- B SENSITIVITY to .005 V/CM
- A SENSITIVITY VERNIER to CAL
- B SENSITIVITY VERNIER to CAL
- A POLARITY to UP+
- B POLARITY to UP+
- A AC/GND/DC to GND
- B AC/GND/DC to GND
- POWER switch up (POWER ON)

- 4-8. DC BAL A+B.
- a. Set Signal Analyzer controls as in Paragraph 4-4.
 - b. Set A+B/ALT to A+B.
 - c. Press both CLEAR DISPLAY pushbuttons.
 - d. Press PROCESS START.
 - e. Observe moving discontinuity on CRT trace.
 - f. Adjust DC BAL A+B to minimize discontinuity; discontinuity should be less than 0.2 cm.
 - g. Check adjustment by repeating steps c, d, and e.
- 4-9. DC BAL A.
- a. Set Signal Analyzer controls as in Paragraph 4-4.
 - b. Set A+B/ALT to ALT.
 - c. Press both CLEAR DISPLAY pushbuttons.
 - d. Press PROCESS START.
 - e. Observe moving discontinuity on CRT trace.
 - f. Adjust DC BAL A to minimize discontinuity; discontinuity should be less than 0.2 cm.
 - g. Check adjustment by repeating steps c, d, and e.
- 4-10. DC BAL B.
- a. Set Signal Analyzer controls as in Paragraph 4-4.
 - b. Set Channel A DISPLAY to OFF.
 - c. Set A+B/ALT to ALT.
 - d. Press both CLEAR DISPLAY pushbuttons.
 - e. Press PROCESS START.
 - f. Observe moving discontinuity on CRT trace.
 - g. Adjust DC BAL B to minimize discontinuity; discontinuity should be less than 0.2 cm.
 - h. Check adjustment by repeating steps d, e, and f.

4-11. BASELINE.

- a. Set Signal Analyzer controls as in Paragraph 4-4.
- b. Set FUNCTION to SUMMATION.
- c. Press both CLEAR DISPLAY pushbuttons.
- d. Press PROCESS START.
- e. Observe moving discontinuity on CRT trace.
- f. Adjust BASELINE ADJ to minimize discontinuity.

NOTE: If bipolar signals are going to be summed, it may be desirable to purposely offset the SUMMATION baseline so cumulative zero crossing errors will not be present in summed waveform.

4-12. CLEANING

4-13. Remove dust and dirt from all assemblies, especially power supplies and memory section. Check printed circuit board contacts for tarnish and/or corrosion. Clean assemblies more often than recommended interval, if Signal Analyzer System is used in a dirty or dusty area.

4-14. For access to internal assemblies, remove instrument top and bottom covers. The five sections of the Model 5480A are located within the instrument as follows:

- a. Display section: Upper left-hand, front.
- b. Main Frame logic section: Lower left-hand, rear.
- c. Memory section: Upper right-hand, front, on swing-out deck. To swing deck, loosen locking screws located at front of deck and lift front of deck.
- d. Switch logic section: Upper right-hand, front, just below front of memory deck.
- e. Power supply section: Lower right-hand, rear.

**4-15. CALIBRATION AND
ADJUSTMENT PROCEDURE**

4-16. Calibration and Adjustment procedure for the Signal Analyzer system is in 5480A Service Manual, Volume I.

CATHODE RAY TUBE WARRANTY

The cathode ray tube (CRT) supplied in the Hewlett-Packard 5480A, and replacement CRTs purchased from HP, are guaranteed by the Hewlett-Packard Company against electrical failure for a period of one year from date of sale. Broken tubes or tubes with burned phosphor are not included under this guarantee. If the CRT is broken when received, a claim should be made with the responsible carrier.

Your nearest Hewlett-Packard Sales and Service office (listed at rear of instrument manual) maintains a stock of replacement tubes and will assist in processing the warranty claim.

In order to ensure credit for a CRT under the warranty period, the reverse side of this sheet should be filled out completely and returned with the defective tube to the nearest HP Sales and Service office. To avoid damage to the tube while in shipment, carefully follow the shipping instructions listed on the reverse side of this sheet; credit is not allowed on broken tubes.

CRT WARRANTY CLAIM

SHIPPING INSTRUCTIONS

1. Carefully wrap the tube in 1/4 inch thick cotton batting or other soft padding material.
2. Wrap the above in heavy kraft paper.
3. Pack wrapped tube in a rigid container which is at least 4 inches larger than the tube in each dimension.
4. Surround the tube with at least 4 inches of packed excelsior or similar shock absorbing material; be sure the packing is tight all around the tube.

FROM: _____ DATE _____

NAME _____

COMPANY _____

ADDRESS _____

For additional information, contact:

NAME _____

COMPANY _____

ADDRESS _____

1. HP INSTRUMENT a) MODEL _____

b) SERIAL NO. _____

2. CRT a) TYPE (on bulb) _____

b) SERIAL NO. (on CRT base) _____

3. Is defective tube original? YES _____ NO _____

4. Date purchased (if available) _____

5. Describe nature and/or symptoms of trouble. _____

6. Describe operation conditions prior to and at time of failure. (Please estimate CRT "on-time" since purchase.) _____

HEWLETT · PACKARD

ELECTRONIC INSTRUMENTATION SALES AND SERVICE

EUROPE, AFRICA, ASIA, AUSTRALIA

EUROPE

<p>AUSTRIA Unifabor GmbH Wissenschaftliche Instrumente Rummelhardtgasse 6/3 P.O. Box 33 Vienna IX/71 Tel: 42 61 81 Cable: LABORINSTRUMENT Vienna</p> <p>BELGIUM Hewlett-Packard Benelux S.A. 348 Boulevard du Souverain Brussels 16 Tel: 72 22 40 Cable: PALOBEN Brussels Telex: 23 494</p> <p>DENMARK Hewlett-Packard A/S Egerang Langebjerg 6 2850 Naerum Tel: 01 80 40 40 Cable: HEWPACK AS Telex: 65 40</p> <p>FINLAND Hewlett-Packard Oy Gyldenitie 3 Helsinki 20 Tel: 67 35 38 Cable: HEWPACKOY-Helsinki Telex: 12-1563</p>	<p>FRANCE Hewlett-Packard France 150 Boulevard Massena 75 Paris 13e Tel: 707 97 19 Cable: HEWPACK Paris Telex: 25048</p> <p>Hewlett-Packard France 4 Quai des Etroits 69 Lyon 5e Tel: 42-63-45</p> <p>GERMANY Hewlett-Packard Vertriebs-GmbH Lietzenburger Strasse 30 1 Berlin W 30 Tel: 24 86 36 Telex: 18 34 05</p> <p>Hewlett-Packard Vertriebs-GmbH Herrenberger Strasse 110 703 Böblingen, Württemberg Tel: 07031-6671 Cable: HEPAAG Böblingen Telex: 72 65 739</p> <p>Hewlett-Packard Vertriebs-GmbH Achenbachstrasse 15 4 Düsseldorf 1 Tel: 68 52 58/59 Telex: 65 86 533</p> <p>Hewlett-Packard Vertriebs-GmbH Kurfürstenstrasse 95 6 Frankfurt 50 Tel: 52 00 36 Cable: HEWPACKSA Frankfurt Telex: 41 32 49</p>	<p>Hewlett-Packard Vertriebs-GmbH Belm Strohhause 26 2 Hamburg 1 Tel: 24 05 51/52 Cable: HEWPACKSA Hamburg Telex: 21 53 32</p> <p>Hewlett-Packard Vertriebs-GmbH Reginfriedstrasse 13 8 Munich 9 Tel: 69 51 21/22 Cable: HEWPACKSA Munich Telex: 52 49 85</p> <p>GREECE Kostas Karayannis 18, Ermou Street Athens 126 Tel: 230 301 Cable: RAKAR Athens Telex: 5962</p> <p>IRELAND Hewlett-Packard Ltd. 224 Bath Road Slough, Bucks, England Tel: Slough 33341 Cable: HEWPIE Slough Telex: 84413</p> <p>ITALY Hewlett-Packard Italiana S.p.A. Viale Lunigiana 46 20125 Milan Tel: 69 15 84 Cable: HEWPACKIT Milan Telex: 32046</p>	<p>Hewlett-Packard Italiana S.p.A. Palazzo Italia Piazza Marconi 25 00144 Rome - Eur Tel: 591 2544 Cable: HEWPACKIT Rome Telex: 61514</p> <p>NETHERLANDS Hewlett-Packard Benelux, N.V. de Boelelaan 1043 Amsterdam, Z.2 Tel: 42 77 77 Cable: PALOBEN Amsterdam Telex: 13 216</p> <p>NORWAY Hewlett-Packard Norge A/S Nesveien 13 Oslo Tel: 53 83 60 Cable: HEWPACK Oslo Telex: 6621</p> <p>PORTUGAL Teletra Rua Rodrigo da Fonseca 103 P.O. Box 2531 Lisboa 1 Tel: 68 60 72 Cable: TELETRA Lisbon Telex: 1598</p> <p>SPAIN Ataio Ingenieros Urgei, 259 Barcelona, 11 Tel: 230-69-88</p> <p>Ataio Ingenieros Enrique Larreta 12 Madrid, 16 Tel: 235 43 44 Cable: TELEATAIO Madrid Telex: 2 72 49</p> <p>SWEDEN HP Instrument AB Hagakergatan 7 Mölnådal Tel: 031 - 27 68 00</p> <p>HP Instrument AB Svetsarsvägen 7 Solna 1 Tel: 98 12 50 Cable: MEASUREMENTS Stockholm Telex: 10721</p> <p>SWITZERLAND HEWPAK AG Zürcherstrasse 20 8952 Schlieren Zürich Tel: (051) 98 18 21 Cable: HEWPACKAG Zurich Telex: 53933</p> <p>HEWPAK A.G. 54 Route des Acacias 1211 Geneva 24 Tel: 43 79 29 Telex: 2 24 86</p> <p>TURKEY Telekom Engineering Bureau P.O. Box 376 - Galata Istanbul Tel: 49 40 40 Cable: TELEMATIK Istanbul</p> <p>UNITED KINGDOM Hewlett-Packard Ltd. 224 Bath Road Slough, Bucks Tel: Slough 33341 Cable: HEWPIE Slough Telex: 84413</p> <p>YUGOSLAVIA Belram S.A. 83 avenue des Mimosas Brussels 15, Belgium Tel: 34 33 32, 34 26 19 Cable: BELRAMEL Brussels Telex: 21790</p> <p>FOR AREAS NOT LISTED, CONTACT: Hewlett-Packard S.A. 54 Route des Acacias 1211 Geneva, Switzerland Tel: (022) 42 81 50 Cable: HEWPACKSA Geneva Telex: 2.24.86</p>
---------------------------------------------------------------------------------------------------------------------------------------------------------------------------------------------------------------------------------------------------------------------------------------------------------------------------------------------------------------------------------------------------------------------------------------------------------------------------------------------------------------------------------------------------------------------------------------------------------------------------------------------------------------------------	------------------------------------------------------------------------------------------------------------------------------------------------------------------------------------------------------------------------------------------------------------------------------------------------------------------------------------------------------------------------------------------------------------------------------------------------------------------------------------------------------------------------------------------------------------------------------------------------------------------------------------------------------------------------------------------------------------------------------------------------------------------------------------------------------------------------------------------------------	------------------------------------------------------------------------------------------------------------------------------------------------------------------------------------------------------------------------------------------------------------------------------------------------------------------------------------------------------------------------------------------------------------------------------------------------------------------------------------------------------------------------------------------------------------------------------------------------------------------------------------------------------------------------------------------------------------------------------------------------------------------------	----------------------------------------------------------------------------------------------------------------------------------------------------------------------------------------------------------------------------------------------------------------------------------------------------------------------------------------------------------------------------------------------------------------------------------------------------------------------------------------------------------------------------------------------------------------------------------------------------------------------------------------------------------------------------------------------------------------------------------------------------------------------------------------------------------------------------------------------------------------------------------------------------------------------------------------------------------------------------------------------------------------------------------------------------------------------------------------------------------------------------------------------------------------------------------------------------------------------------------------------------------------------------------------------------------------------------------------------------------------------------------------------------------------------------------------------------------------------------------------------------------------------------------------------------------------------------------------------------------------------------------------------------------------------------------------------------------------------------------------------------------------------------------------------------------------------------------------------------------------------------------------------------------------------------------------------------------------------------------------------------------------------------------------------------------------------

AFRICA, ASIA, AUSTRALIA

<p>ANGOLA Teletra Box 6487 Luanda Cable: TELETRA Luanda</p> <p>AUSTRALIA Hewlett-Packard Australia Pty. Ltd. 22-26 Weir Street Glen Iris, 3146 Victoria Tel: 20.1371 (4 lines) Cable: HEWPARD Melbourne Telex: 31024</p> <p>Hewlett-Packard Australia Pty. Ltd. 61 Alexander Street Crows Nest 2065 New South Wales Tel: 43.7866 Cable: HEWPARD Sydney</p> <p>Hewlett-Packard Australia Pty. Ltd. 97 Churchill Road Prospect 5082 South Australia Tel: 65.2366 Cable: HEWPARD Adelaide</p> <p>CEYLON United Electricals Ltd. P.O. Box 681 Yahala Building Staples Street Colombo 2 Tel: 5996 Cable: HOTPOINT Colombo</p> <p>CYPRUS Kypriacs 16-19D Hommer Avenue P.O. Box 752 Nicosia Tel: 6282-75628 Cable: HE-I-NAMI</p>	<p>ETHIOPIA African Salespower & Agency Private Ltd., Co. P. O. Box 718 58/59 Cunningham St. Addis Ababa Tel: 12285 Cable: ASACO Addisababa</p> <p>HONG KONG Schmidt & Co. (Hong Kong) Ltd. P.O. Box 297 1511, Prince's Building 10, Chater Road Hong Kong Tel: 240168, 232735 Cable: SCHMIDTCO Hong Kong</p> <p>INDIA The Scientific Instrument Co., Ltd. 6, Tej Bahadur Sapru Road Allahabad 1 Tel: 2451 Cable: SICO Allahbad</p> <p>The Scientific Instrument Co., Ltd. 240, Dr. Dadabhai Naoroji Road Bombay 1 Tel: 26-2642 Cable: SICO Bombay</p> <p>The Scientific Instrument Co., Ltd. 11, Esplanade East Calcutta 1 Tel: 23-4129 Cable: SICO Calcutta</p> <p>The Scientific Instrument Co., Ltd. 50, Mount Road Madras 2 Tel: 86339 Cable: SICO Madras</p> <p>The Scientific Instrument Co., Ltd. B-7, Ajmeri Gate Extn. New Delhi 1 Tel: 27-1053 Cable: SICO New Delhi</p>	<p>IRAN Telecom, Ltd. P. O. Box 1812 240 Kh. Saba Shomali Teheran Tel: 43850, 48111 Cable: BASCOM Teheran</p> <p>ISRAEL Electronics & Engineering Div. of Motorola Israel Ltd. 16, Kremenski Street Tel-Aviv Tel: 35021 (4 lines) Cable: BASTEL Tel-Aviv Telex: Bastel TV 033-569</p> <p>JAPAN Yokogawa-Hewlett-Packard Ltd. Nisei Ibaragi Bldg. 2-2-8 Kasuga Ibaragi-Shi Osaka Tel: 0726-23-1641</p> <p>Yokogawa-Hewlett-Packard Ltd. Ito Building No. 59, Kotori-cho Nakamura-ku, Nagoya City Tel: 551-0215</p> <p>Yokogawa-Hewlett-Packard Ltd. Ohashi Building No. 59, I-chome, Yoyogi Shibuya-ku, Tokyo Tel: 370-2281 Telex: YIHPMARKET TOK 23-724</p>	<p>KENYA R. J. Tilbury Ltd. P. O. Box 2754 Suite 517/518 Hotel Ambassador Nairobi Tel: 25670, 26803, 68206, 58196 Cable: ARJAYTEE Nairobi</p> <p>KOREA American Trading Co., Korea, Ltd. P.O. Box 1103 Dae Kyung Bldg. 170 Sejung Ro Chongro Ku Seoul Tel: 75-5841 Cable: AMTRACO Seoul</p> <p>LEBANON Constantin E. Macridis Clemenceau Street Clemenceau Center Beirut Tel: 202846 Cable: ELECTRONUCLEAR Beirut</p> <p>MALAYSIA MECOMB Malaysia Ltd. 2 Lorong 13/6A Section 13 Petaling Jaya, Selangor Cable: MECOMB Kuala Lumpur</p> <p>NEW ZEALAND Hewlett-Packard (N.Z.) Ltd. 32-34 Kent Terrace Wellington, N.Z. Tel: 56-409 Cable: HEWPACK Wellington</p> <p>PAKISTAN (EAST) Mushko & Company, Ltd. 31, Jinnah Avenue Dacca Tel: 80058 Cable: NEWDEAL Dacca</p>	<p>PAKISTAN (WEST) Mushko & Company, Ltd. Oosman Chambers Victoria Road Karachi 3 Tel: 51027, 52927 Cable: COOPERATOR Karachi</p> <p>SINGAPORE Mechanical and Combustion Engineering Company Ltd. 9, Jalan Kilang Singapore, 3 Tel: 642361-3 Cable: MECOMB Singapore</p> <p>SOUTH AFRICA F. H. Flanzer & Co. (Pty.), Ltd. Hill House 43 Somerset Rd. Cape Town Tel: 2-9711 Cable: AUTOPHONE Cape Town Telex: 7038CT</p> <p>F. H. Flanzer & Co. (Pty.), Ltd. 607 Pharmacy House 80 Jorissen Street Bramfontein, Johannesburg Tel: 724-4172 Telex: 0026 JHB</p> <p>TAIWAN Hwa Sheng Electronic Co., Ltd. P. O. Box 1558 21 Nanking West Road Taipei Tel: 46076, 45936, 48661 Cable: VICTRONIX Taipei</p> <p>TANZANIA R. J. Tilbury Ltd. P.O. Box 2754 Suite 517/518 Hotel Ambassador Nairobi Tel: 25670, 26803, 68206, 58196 Cable: ARJAYTEE Nairobi</p>	<p>THAILAND The International Engineering Co., Ltd. P. O. Box 39 614 Sukhumvit Road Bangkok Tel: 910722 Cable: GYSOM Bangkok</p> <p>UGANDA R. J. Tilbury Ltd. P.O. Box 2754 Suite 517/518 Hotel Ambassador Nairobi Tel: 25670, 26803, 68206, 58196 Cable: ARJAYTEE Nairobi</p> <p>VIETNAM Landis Brothers and Company, Inc. P.O. Box H-3 216 Hien-Vuong Saigon Tel: 20.805 Cable: LANBROCOMP Saigon</p> <p>ZAMBIA R. J. Tilbury (Zambia) Ltd. P.O. Box 2792 Lusaka Zambia, Central Africa</p> <p>FOR AREAS NOT LISTED, CONTACT: Hewlett-Packard Export Marketing 3200 Hillview Ave. Palo Alto, California 94304 Tel: (415) 326-7000 TWX: 910-373-1267 Cable: HEWPACK Palo Alto Telex: 034-8461</p>
------------------------------------------------------------------------------------------------------------------------------------------------------------------------------------------------------------------------------------------------------------------------------------------------------------------------------------------------------------------------------------------------------------------------------------------------------------------------------------------------------------------------------------------------------------------------------------------------------------------------------------------------------------------------------------------------------------------------------------------------------------------------------------------------------------------------------------------------------------------------------------------------------------	--------------------------------------------------------------------------------------------------------------------------------------------------------------------------------------------------------------------------------------------------------------------------------------------------------------------------------------------------------------------------------------------------------------------------------------------------------------------------------------------------------------------------------------------------------------------------------------------------------------------------------------------------------------------------------------------------------------------------------------------------------------------------------------------------------------------------------------------------------------------------------------------------------------------------------------------------------------------------------------------------------------------------------------------------------------------------	------------------------------------------------------------------------------------------------------------------------------------------------------------------------------------------------------------------------------------------------------------------------------------------------------------------------------------------------------------------------------------------------------------------------------------------------------------------------------------------------------------------------------------------------------------------------------------------------------------------------------------------------------------------------------------------------------------------------------------------------------------------------------------------------------	----------------------------------------------------------------------------------------------------------------------------------------------------------------------------------------------------------------------------------------------------------------------------------------------------------------------------------------------------------------------------------------------------------------------------------------------------------------------------------------------------------------------------------------------------------------------------------------------------------------------------------------------------------------------------------------------------------------------------------------------------------------------------------------------------------------------------------------------------------------------------------------------------------------------------------------------------------------------	-----------------------------------------------------------------------------------------------------------------------------------------------------------------------------------------------------------------------------------------------------------------------------------------------------------------------------------------------------------------------------------------------------------------------------------------------------------------------------------------------------------------------------------------------------------------------------------------------------------------------------------------------------------------------------------------------------------------------------------------------------------------------------------------------------------------------------------------------------------------------------------------------------------------------------------------------------------------------------------------------------------------------------------------------------------	---------------------------------------------------------------------------------------------------------------------------------------------------------------------------------------------------------------------------------------------------------------------------------------------------------------------------------------------------------------------------------------------------------------------------------------------------------------------------------------------------------------------------------------------------------------------------------------------------------------------------------------------------------------------------------------------------------------------------------------------------------------------------------------------------------------------------------------------------------------------------

