

HP Archive

This vintage Hewlett Packard document was preserved
and distributed by

[www. hparchive.com](http://www.hparchive.com)

Please visit us on the web !

On-line curator: Glenn Robb

This document is for FREE distribution only!

INSTRUCTION AND OPERATING MANUAL
FOR

MODEL 415A
STANDING WAVE INDICATOR

Serial 2852 and above

Copyright 1954 by Hewlett-Packard Company.
The information contained in this booklet
is intended for the operation and main-
tenance of Hewlett-Packard equipment
and is not to be used otherwise or repro-
duced without the written consent of the
Hewlett-Packard Company.

Hewlett-Packard Company
295 Page Mill Road
Palo Alto, California

General Description

The Model 415A Standing Wave Indicator is designed for use with Hewlett-Packard slotted lines and detector mounts.

The Standing Wave Indicator consists of an amplifier and rectifier type voltmeter. The amplifier is frequency selective and has an extremely low noise level. The output of the amplifier is measured with a square-law calibrated voltmeter. A 60 db attenuator adjustable in 10 db steps provides a calibrated range of 70 db. A gain control is provided for adjusting the meter to a convenient level.

The instrument may be operated with either a crystal or bolometer detector. A bias supply within the instrument makes it possible to use either a high or low current bolometer.

Specifications

Frequency --

1,000 cycles/sec. $\pm 2\%$

Sensitivity -

.3 microvolts input produces full scale meter deflection.

Noise Level --

Equivalent noise referred to input less than .04 microvolts.

Amplifier Q --

20 \pm 5

Calibration --

For use with square law detector. Meter indicates VSWR and DB.

Range --

70 db input attenuator provides 60 db attenuation in 10 db steps.
Accuracy \pm .1 db per 10 db step.

Gain Control --

Adjusts meter to convenient level. Range approximately 30 db.

Input --

- a. 200 ohms bias provided for 8.75 ma. bolometer or 1/100 ampere instrument fuse; or 4.5 ma. low current bolometer.
- b. 200 ohms for crystal rectifier.
- c. 75,000 ohms for crystal rectifier for use as a null indicator.

Accessories Furnished -

	<u>Quantity</u>	<u>Length</u>	<u>Type</u>	<u>Termination</u>
Input Cable	1	44"	RG55/U	UG88/U Connector one end, other end open
Meter Cable	1	26"	Two Cord Ripcord	Telephone plug one end, other end open

Power Supply Rating --

Voltage	115/230 volts $\pm 10\%$
Frequency	50/60 cycles/sec.
Wattage	60 watts

Overall Dimensions

Cabinet Model	12-1/2" wide x 9 3/4" high x 10-1/4" deep
Rack Model	19" wide x 8 3/4" high x 10-1/4" deep Panel size - 19" wide x 8 3/4" high Depth behind panel - 9-1/4"

Weight --

Cabinet Model	17 lbs. including accessories
Rack Model	20 lbs. including accessories

Operating Instructions

Inspection --

This instrument has been thoroughly tested and inspected before being shipped from the factory. After the instrument is unpacked, it should be carefully checked for damage received in transit. If any shipping damage is found, follow the procedure outlined in the "Claim for Damage in Shipment" section on the last page of this instruction book.

Control and Terminals --

CRYSTAL - BOLOMETER - 75,000 Ω - This switch is provided so that the input circuit constants may be readily changed to match the characteristics of the crystal or bolometer connected to the input of the instrument. The input character is obtained at each switch position as described below:

CRYSTAL - Provides 200 ohms input impedance for use with a crystal rectifier.

BOLOMETER - Provides 200 ohms input impedance for use with a bolometer or 1/100 ampere instrument fuse. Also provides bias for the bolometer or instrument fuse.

CURRENT - This jack is provided so that a milliammeter may be inserted in the bias circuit to measure the current flowing through the bolometer or instrument fuse. A two conductor cable with a telephone plug on one end is supplied with the instrument for connecting a milliammeter to the instrument.

INPUT This BNC type connector is the input terminal of the instrument. An input cable consisting of a UG88/U connector on one end of a RC55/U cable is provided for connecting the instrument to the crystal or bolometer.

SWR - DB This control is a three section voltage divider with one divider in the grid circuit of each of the first three amplifier tubes. It attenuates the signal in 10 db steps to a maximum attenuation of 60 db.

HIGH LOW This toggle switch, located on the top of the chassis deck, is provided so that a bias current of either 8.75 ma. or 4.5 ma. may be supplied to the bolometer in use.

GAIN - This variable resistor controls the signal voltage applied to the fourth amplifier stage and therefore, the output of the amplifier.

FUSE - The fuseholder, located on the control panel, contains a 1 ampere cartridge fuse. To replace the fuse, unscrew the fuseholder cap and remove the blown fuse. Insert a new fuse of the same type and replace the fuseholder cap. For 230 volt operation this fuse should have a 1/2 ampere rating. Replacement fuses should be of the "Slo-Blo" type as specified in the Table of Replaceable Parts in this instruction manual.

ON - This switch controls the power supplied to the instrument from the power line. The red indicator lamp, on the control panel, lights when the power switch is turned on.

Operation --

Note: This instrument is shipped from the factory with the power transformer primaries connected for 115 volt operation. If operation from a 230 volt power source is desired, connect the transformer primaries as shown on the schematic diagram in this instruction manual.

The procedure for operating the instrument is as follows:

Connect the instrument to the power line and the input cable to the INPUT terminal. Allow the instrument to reach operating temperature.

Crystal Detector

1. Connect the crystal rectifier to the input cable. Set the CRYSTAL--75,000 μ switch to the CRYSTAL position.
2. Set the SWR-DB and GAIN control so that a readable meter indication is obtained. Vary the modulation frequency to obtain a peak meter indication. This insures that the modulation frequency is tuned to the frequency of the filter in the Model 415A.
3. Adjust the GAIN and attenuator controls for the desired meter indication and perform the measurements as described in the instruction book of the slotted line or other equipment in use.

Bolometer

1. Connect the bolometer to the outer end of the input cable. Connect a milliammeter to the meter cable supplied with the instrument and insert the telephone plug in the CURRENT jack. Set the HIGH - LOW switch for the range of current required by the bolometer. A variable resistance may be connected in series with the milliammeter if it is necessary to control the current through the bolometer.
2. Set the CRYSTAL - 75,000 Ω switch to bolometer and repeat steps 2 and 3 of the crystal operation procedure.

Null Detector

1. Connect the INPUT cable to the bridge circuit. Set the CRYSTAL - 75,000 Ω switch to the 75,000 ohms position.
2. Adjust the frequency supplied to the bridge circuit so that a maximum deflection is produced on the Model 415A meter. Adjust the GAIN and attenuator control to obtain a readable indication.
3. As the bridge approaches balance, the gain of the Model 415A should be increased to obtain an accurate null point.

It should be remembered when making measurements with the Model 415A that the instrument is calibrated for use with a square law detector. If the voltage applied to the instrument has a linear relationship or is derived from a linear detector, the calibration of the Model 415A will be incorrect.

For example, if the instrument is fed by a square law detector and this detector is supplied from a signal generator, the db scale on the Model 415A and on the signal generator will check as the voltage is increased or decreased. However, if the Model 415A is supplied directly from the signal generator, the reading of the Model 415A will change 5 db when a 10 db change is made in the output of the signal generator.

Circuit Description

The Model 415A Standing Wave Indicator consists of a frequency selective amplifier feeding a full-wave rectifier type voltmeter, a voltage regulator circuit, and a power supply.

The input circuit is arranged so that its characteristics may be changed to match various detectors. The CRYSTAL position of the CRYSTAL - BOLOMETER - 75,000 Ω switch connects an external crystal detector to the primary of the input transformer T2. The BOLOMETER switch position connects an external bolometer between the chassis and one end of the input transformer primary winding. The other end of the winding is connected to the bias voltage obtained from the voltage across the current regulator tube V7. A filter and voltage

divider network are connected between the transformer and tube V7 to eliminate undesirable voltages in the input to the amplifier and in conjunction with the HIGH - LOW switch to provide either a high or low current through the external bolometer. The 75,000 Ω position of the switch eliminates the input transformer and connects the INPUT terminal through capacitor C25 to the grid of tube V1A.

Tubes V1AB, V2AB, V3AB form a linear amplifier which is made frequency selective by a resistance capacity filter in an negative feed back circuit.

Tubes V1AB and V2A amplify the signal. However, each tube has a voltage divider in its grid circuit to control the gain of the amplifier. The switches for these dividers are mechanically connected to form the SWR-DB control. The attenuator is designed to attenuate in steps of 20 db. However, due to the square law calibration of the instrument each step is designated as a 10 db change.

A resistance capacity filter (R47-R49, C22-C24) in the grid circuit of tube V2A removes the 60 cycle component from the signal.

After being amplified by the first three stages, the signal is supplied to the grid of tube V2B through the voltage divider R16 (GAIN) which has a range of approximately 30 db.

The frequency selection function of the amplifier is performed by tube V2B and its associated resistance capacity filter network (R33-R35, C12-C14). The signal from the plate of tube V2B fed through the filter network to the grid of tube V2B. The filter prevents the 1000 cycle voltage from being applied to the grid of V2B. However, any other frequencies in the signal are greatly attenuated by the negative feed-back. The amount of negative feed-back is controlled by the capacity across the cathode resistor of tube V2B. The effect of this capacity is controlled by the variable resistor R22.

The 1000 cycle voltage from V2B is amplified by tube V3AB and applied to the meter circuit. The crystal rectifiers CR1, CR2 change the 1000 cycle voltage to direct current which is indicated by the milliammeter M. While this meter is average reading, the meter is calibrated in terms of the voltage derived from a square law detector.

The power supply and electronic voltage regulator are conventional.

Maintenance

Cover and Bottom Plate Removal --

Remove the four screws which fasten the cover to the chassis. Remove the cover by sliding it to the rear.

The bottom plate is removed by unscrewing the four screws which fasten the plate to the chassis.

Tube Replacement --

Any tube in the Model 415A may be replaced with a tube having RETMA standard characteristics. However, select a non-microphonic tube when replacing tube V1. A microphonic tube in this position will affect the accuracy of the instrument. When tube V2AB is replaced the Q of the instrument should be measured and adjusted if necessary.

All the tubes are accessible when the cover is removed. The location of the tubes is shown in Figure 2.

Adjustment of Regulated Power Supply Voltage Level --

The procedure for performing this adjustment is as follows:

Auxiliary Test Equipment Required:

Variable auto-transformer or other equipment for supplying 102V and 128V to the Model 415A, Hewlett-Packard Model 410B voltmeter or other high resistance DC voltmeter.

1. Connect the Model 415A to the auto-transformer. Turn the power switch to ON, and allow a few minutes for warm-up.
2. Connect the DC voltmeter between pin 8 of tube V5 and the chassis. Measure the DC voltage. This voltage should be 240 volts at 115V line voltage. Check the DC voltage at 102V and 128V line voltage. If the voltage is 240 volts over the line voltage range then the voltage regulator is properly adjusted.
3. If the DC voltage does not stay at the same level over the 102V to 128V line voltage range, then replacement of one or more of the regulator tubes V5, V6, or V7 will be necessary.
4. If the voltage is not 240 volts, then adjust R44 (See Fig. 4) so as to obtain this voltage. Check at 102V and 128V line voltage.

Adjustment of Hum Balance Control --

The procedure for balancing out the hum voltage is as follows:

Auxiliary Test Equipment Required:

Audio oscillator capable of supplying .1 volt at 1,000 cycles/sec. to the input of the Model 415A.

Vacuum tube voltmeter suitable for measuring oscillator output voltage. Hewlett-Packard Models 400A, 400B, 400C, 400D, 410A, or 410B.

1. Turn the power switch to ON. Set the CRYSTAL BOLOMETER - 75,000 switch to the CRYSTAL position. Set the SWR-DB switch to the 0 position. Turn the GAIN control to nearly maximum.
2. Connect the oscillator to the INPUT terminal of the instrument. Adjust the oscillator to filter frequency and .1 volt output. Re-adjust the oscillator frequency for maximum deflection of the Model 415A meter. Set the GAIN control so that the meter pointer coincides with the nearest db mark.
3. Disconnect oscillator from the Model 415A. Short circuit the INPUT terminals of the Standing Wave Indicator. Set the SWR-DB switch to the 60 db position. Adjust the variable resistor R39 for minimum meter indication.

Adjustment of Audio Filter Q

The following procedure for adjusting the audio filter to the desired Q may also be used when a different frequency filter is installed in the instrument.

Auxiliary Test Equipment Required:

Hewlett-Packard Model 200I oscillator.

1. Turn the power switch to ON. Set the CRYSTAL BOLOMETER - 75,000 switch to the CRYSTAL position. Set the SWR-DB switch to the 0 position. Turn the GAIN control to maximum.
2. Connect the oscillator to the INPUT terminal of the instrument. Adjust the oscillator to the filter frequency and set the output so that the Model 415A meter indicates exactly 0 db. Note the resonant frequency of the filter.
3. Increase the oscillator frequency about 100 cycles and then reduce the frequency until the meter indicates 1.5 db. Note the frequency at this point. Continue to lower the frequency until the meter again indicates 1.5 db. Note the frequency at this point. Subtract the frequency obtained at the second 1.5 db point from the frequency at the first 1.5 db point. This is the bandwidth. Then Q is equal to the resonant frequency of the filter divided by the bandwidth.

Example:

First 1.5 db point frequency	=	1025 cycles/sec.
Second 1.5 db point frequency	=	980 cycles/sec.
Resonant frequency of filter	=	1000 cycles/sec.

$$\frac{1025}{980} \text{ cycles/sec. bandwidth}$$

$$Q = \frac{1000}{45} = 22.2$$

4. If the Q is not within the specified limits then adjust R22 (See Fig. 2) slightly and repeat steps 2 and 3. Repeat the measurements and adjustment until the Q is satisfactory.

Trouble Shooting --

The following information is designed to be of assistance in trouble shooting a defective instrument.

<u>Symptoms</u>	<u>Possible Cause</u>	<u>Test Procedure</u>	<u>Remedies</u>
Instrument NOT operating, pilot light NOT on.	Line fuse blown due to defective fuse, power line surge, or overload in power supply section of the instrument.	Replace fuse, if this fuse blows remove V4, and again replace the fuse. If this fuse blows it is an indication of: 1. Short circuit in wiring associated with power transformer T1. 2. Short circuit in filament wiring. 3. Defective power transformer. If fuse does not blow when V4 is removed, it indicates: 1. Defective rectifier tube V4. 2. Short circuit in direct current wiring. 3. Defective filter capacitor.	1. Locate and clear short circuit. 2. Locate and clear short circuit. 3. Replace power transformer. 1. Replace tube V4. 2. Locate and clear short circuit. 3. Locate and replace defective capacitor.
Instrument NOT operating, pilot ON.	Defective tube. Short circuit in capacitors C1A, C1B, C1C, or the coupling capacitor C3, C6, C9, C11, C16, C18.	Check the rectifier tube V4 first.	Replace defective tube. See "Tube Replacement" in the Maintenance Section. Replace defective capacitor.

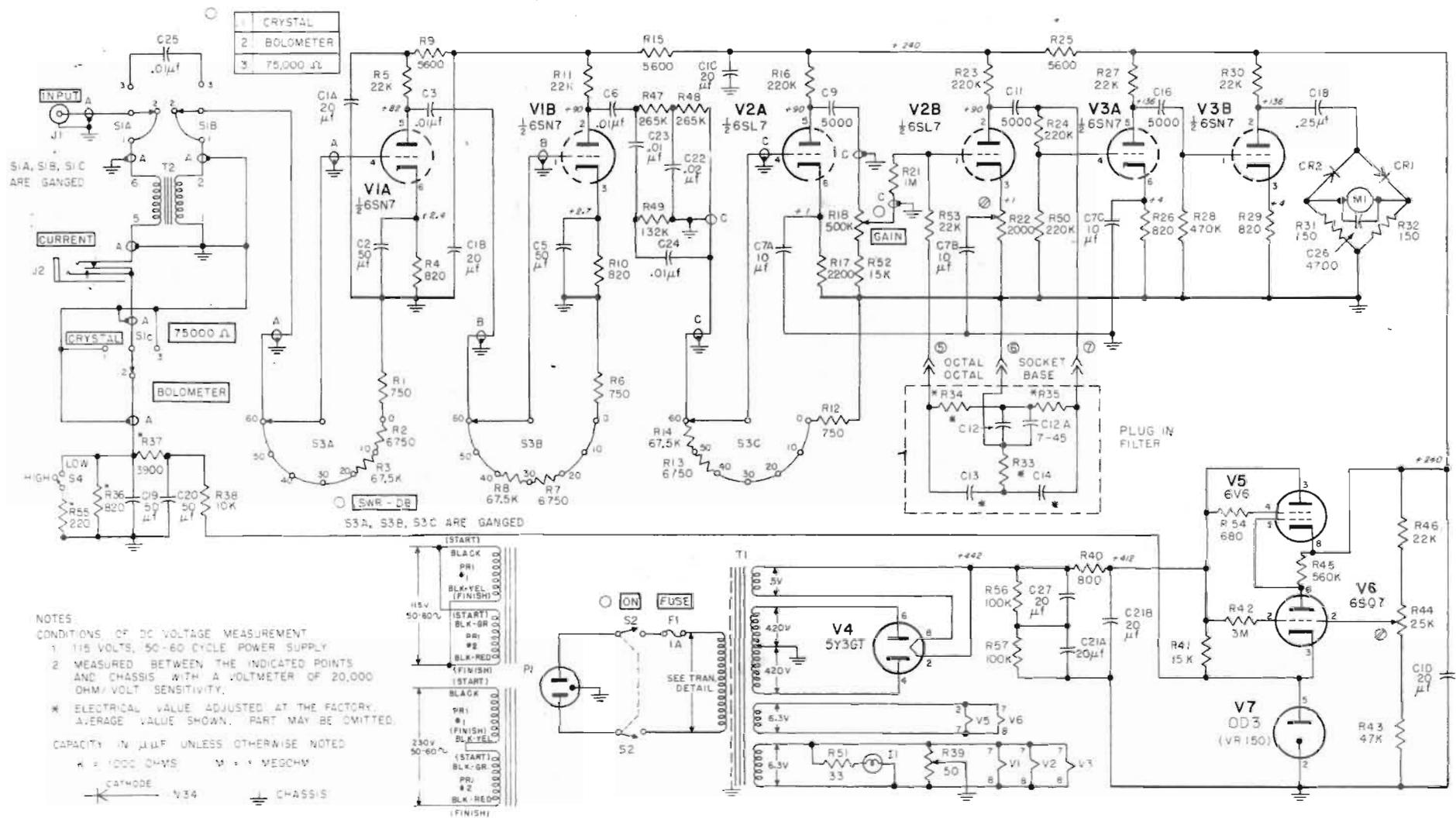

SCHMATIC DIAGRAM OF MODEL 415A
SERIAL 2852 & ABOVE

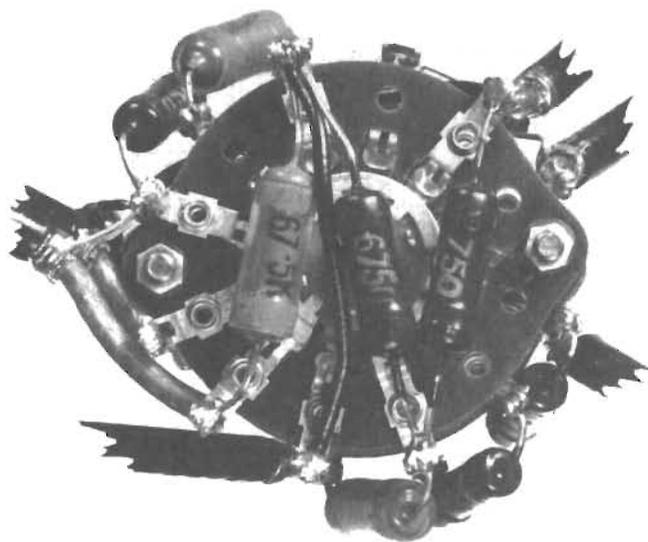
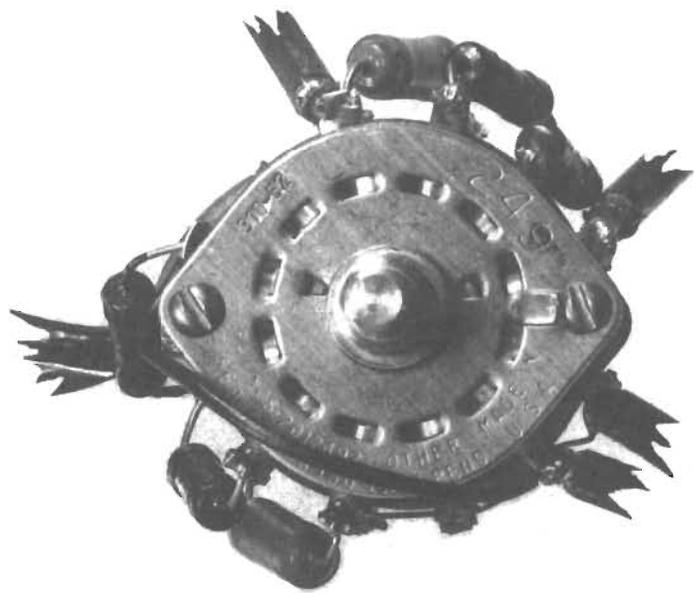

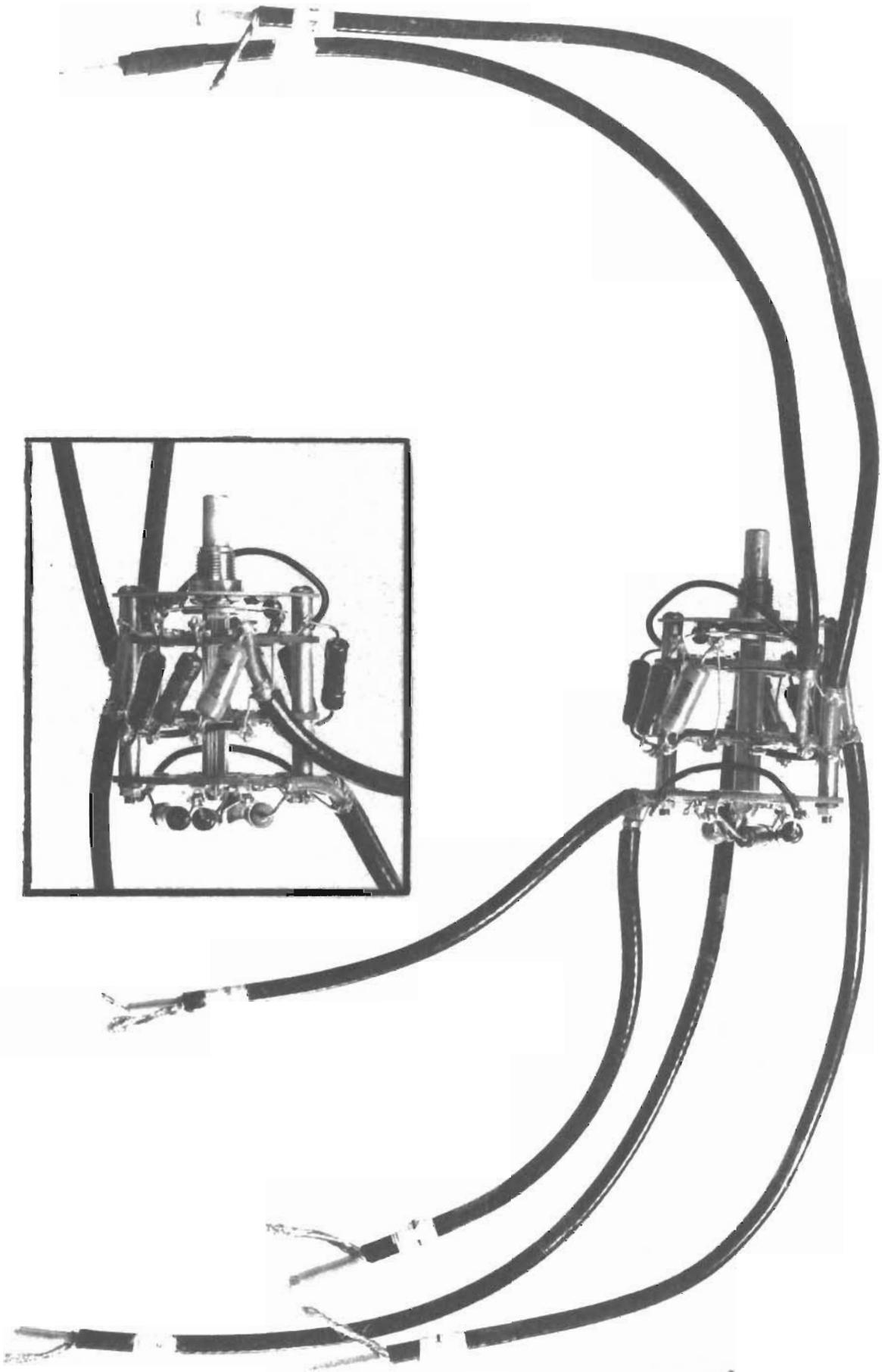

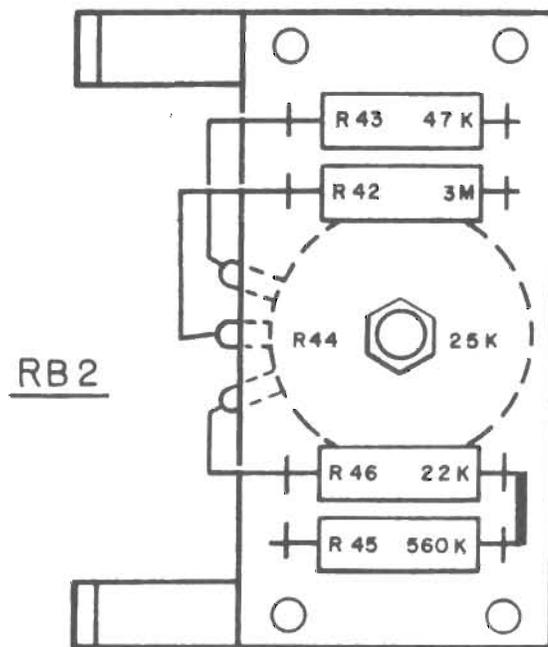
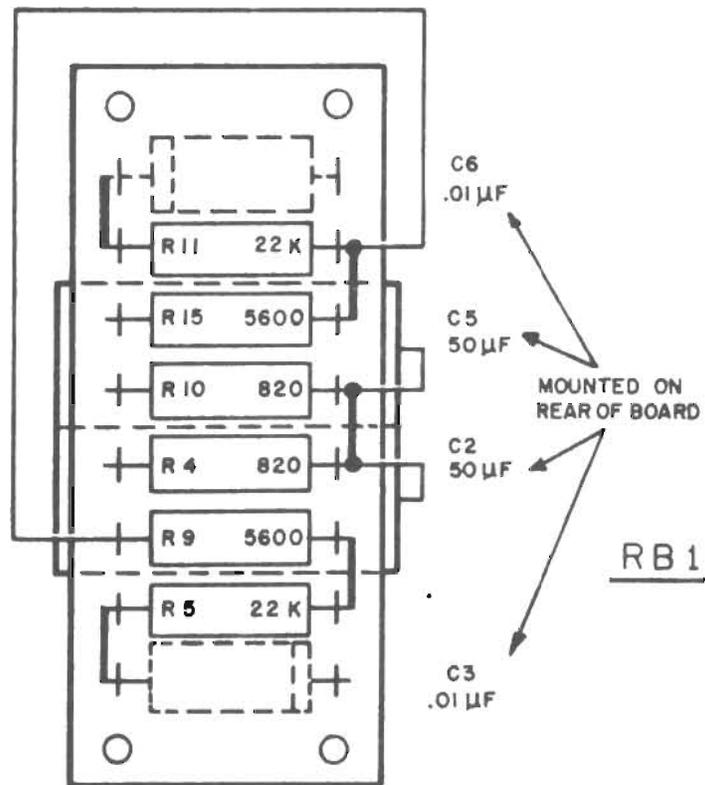

Figure 4. Model 415A Resistor Board Detail

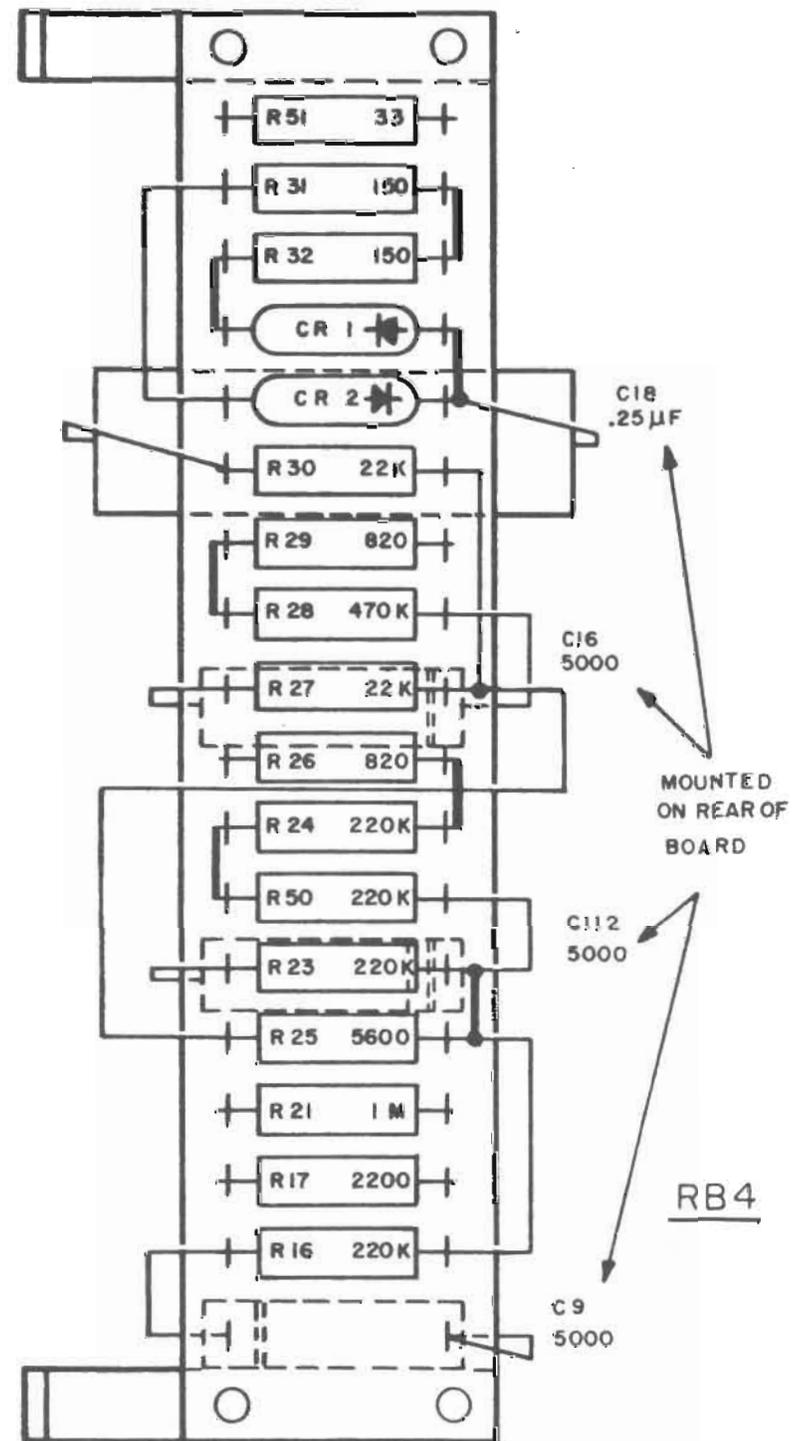
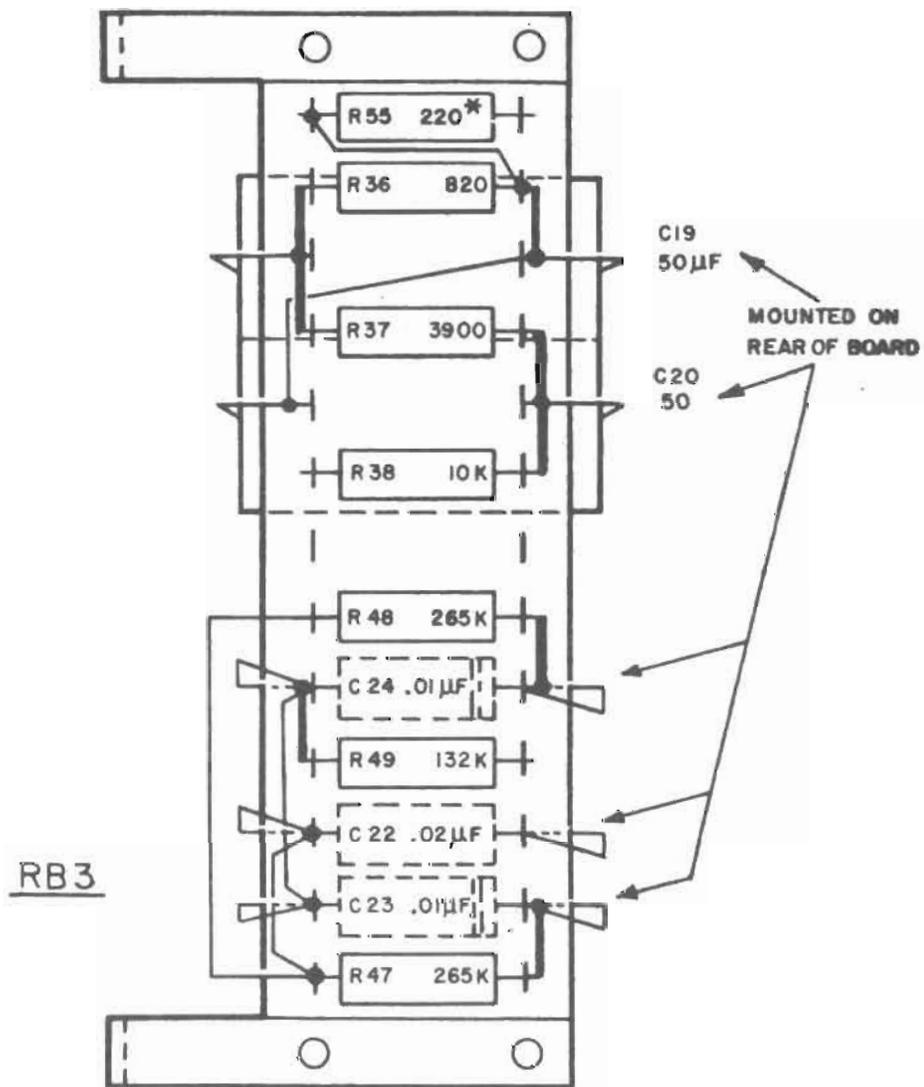

Figure 5. Model 415A Resistor Board Detail

TABLE OF REPLACEABLE PARTS

Circuit Ref.	Description	-hp- Stock No.	Mfr. * & Mfrs. Designation
C1A, B, C, D	Capacitor: fixed, electrolytic, 20, 20, 20, 20 μ f, 450 vdcw	18-42	X EP-444
C2	Capacitor: fixed, electrolytic, 50 μ f, +200%, -10%, 50 vdcw	18-50	A PRS-EP
C3	Capacitor: fixed, paper, .01 μ f, \pm 10%, 600 vdcw	16-11	A Type P688
C4	This circuit reference not assigned		
C5	Capacitor: fixed, electrolytic, 50 μ f, +200%, -10%, 50 vdcw	18-50	A PRS-EP
C6	Capacitor: fixed, paper, .01 μ f, \pm 10%, 600 vdcw	16-11	A Type P688
C7A, F, C	Capacitor: fixed, electrolytic, 10, 10, 10 μ f, 450 vdcw	18-31	X FPT-389
C8	This circuit reference not assigned		
C9	Capacitor: fixed, paper, 5000 μ f, \pm 10%, 600 vdcw	16-25	CC 73P47296
C10	This circuit reference not assigned		
C11	Capacitor: fixed, paper, 5000 μ f, \pm 10%, 600 vdcw	16-25	CC 73P47296
C12	Capacitor: Part of audio filter		
C12A	Capacitor: Part of audio filter		
C13	Capacitor: Part of audio filter		
C14	Capacitor: Part of audio filter		
C15	This circuit reference not assigned		
C16	Capacitor: fixed, paper, 5000 μ f, \pm 10%, 600 vdcw	16-25	CC 73P47296
C17	This circuit reference not assigned		
C18	Capacitor: fixed, paper, .25 μ f, \pm 10%, 400 vdcw	16-48	A P488
C19	Capacitor: fixed, electrolytic, 50 μ f, +200%, -10%, 50 vdcw	18-50	A PRS-EP
C20	Capacitor: fixed, electrolytic, 50 μ f, +200%, -10%, 50 vdcw	18-50	A PRS-EP

*See "List of Manufacturers Code Letters For Replaceable Parts Table."

TABLE OF REPLACEABLE PARTS

Circuit Ref.	Description	-hp- Stock No.	Mfr. * & Mfrs. Designation
R9	Resistor: fixed, composition, 5,600 ohms, $\pm 10\%$, 1 W	24-5600	B GB 5621
R10	Resistor: fixed, composition, 820 ohms, $\pm 10\%$, 1/2 W	23-820	B EB 8211
R11	Resistor: fixed, composition, 22,000 ohms, $\pm 10\%$, 1 W	24-22K	B GB 2231
R12	Resistor: fixed, composition, 750 ohms, Part of Input Atten # 41A-34		
R13	Resistor: fixed, composition, 6750 ohms, Part of Input Atten. # 41A-34		
R14	Resistor: fixed, composition, 67,500 ohms, Part of Input Atten. # 41A-34		
R15	Resistor: fixed, composition, 5,600 ohms, $\pm 10\%$, 1 W	24-5600	B GB 5621
R16	Resistor: fixed, composition, 220,000 ohms, $\pm 10\%$, W	23-220K	B EB 2241
R17	Resistor: fixed, composition, 2,200 ohms, $\pm 10\%$, 1/2 W	23-2200	B EB 2221
R18	Resistor: variable, composition, 500,000 ohms, linear taper	210-59	HP
R19, R20	These circuit references not assigned		
R21	Resistor: fixed, composition, 1 megohm, $\pm 10\%$, 1/2 W	23-1M	B EB 1051
R22	Resistor: variable, composition, 2,000 ohms,	210-14	
R23	Resistor: fixed, composition, 220,000 ohms, $\pm 10\%$, 1/2 W	23-220K	B EB 2241
R24	Resistor: fixed, composition, 220,000 ohms, $\pm 10\%$, 1/2 W	23-220K	B EB 2241
R25	Resistor: fixed, composition, 5,600 ohms, $\pm 10\%$, 1 W	24-5600	B GB 5621
R26	Resistor: fixed, composition, 820 ohms, $\pm 10\%$, 1/2 W	23-820	B EB 8211

*See "List of Manufacturers Code Letters For Replaceable Parts Table."

TABLE OF REPLACEABLE PARTS

Circuit Ref.	Description	-hp- Stock No.	Mfr. * & Mfrs. Designation
C21A,B	Capacitor: fixed, electrolytic, 20,20 μ f, 450 vdcw	18-22	A AEF-1"X3"
C22	Capacitor: fixed, paper, .02 μ f, $\pm 10\%$, 600 vdcw	16-12	CC 73P22396
C23	Capacitor: fixed, paper, .01 μ f, $\pm 10\%$, 600 vdcw	16-11	A Type P688
C24	Capacitor: fixed, paper, .01 μ f, $\pm 10\%$, 600 vdcw	16-11	A Type P688
C25	Capacitor: fixed, paper, .01 μ f, $\pm 10\%$, 600 vdcw, Part of Crystal Bolometer Switch and Cable Assembly.	16-11	A Type P688
C26	Capacitor: fixed, mica, 4700 μ f, $\pm 10\%$, 500 vdcw	14-44	Z C-1247
C27	Capacitor: fixed, electrolytic, 20 μ f, 450 vdcw	18-20	X FPS-144
R1	Resistor: fixed, composition, 750 ohms, Part of Input Atten. #41A-34		
R2	Resistor: fixed, composition, 6750 ohms, Part of Input Atten. # 41A-34		
R3	Resistor: fixed, composition, 67,500 ohms, Part of Input Atten. # 41A-34		
R4	Resistor: fixed, composition, 820 ohms, $\pm 10\%$, 1/2 W	23-820	B EB 8211
R5	Resistor: fixed, composition, 22,000 ohms, $\pm 10\%$, 1 W	24-22K	B GB 2231
R6	Resistor: fixed, composition, 750 ohms, Part of Input Atten. # 41A-34		
R7	Resistor: fixed, composition, 6750 ohms, Part of Input Atten. # 41A-34		
R8	Resistor: fixed, composition, 67,500 ohms, Part of Input Atten. # 41A-34		

*See "List of Manufacturers Code Letters For Replaceable Parts Table."

TABLE OF REPLACEABLE PARTS

Circuit Ref.	Description	-hp- Stock No.	Mfr. * & Mfrs. Designation
R27	Resistor: fixed, composition, 22,000 ohms, $\pm 10\%$, 1 W	24-22K	B GB 2231
R28	Resistor: fixed, composition, 470,000 ohms, $\pm 10\%$, 1/2 W	23-470K	B EB 4741
R29	Resistor: fixed, composition, 820 ohms, $\pm 10\%$, 1/2 W	23-820	B EB 8211
R30	Resistor: fixed, composition, 22 000 ohms, $\pm 10\%$, 1 W	24-22K	B GB 2231
R31	Resistor: fixed, composition, 150 ohms, $\pm 10\%$, 1/2 W	23 150	B EB 1511
R32	Resistor: fixed, composition, 150 ohms, $\pm 10\%$, 1/2 W	23-150	B EB 1511
R33	Resistor: Part of Audio Filter Electrical value adjusted at factory		
R34	Resistor: Part of Audio Filter Electrical value adjusted at factory		
R35	Resistor: Part of Audio Filter Electrical value adjusted at factory		
R36	Resistor: fixed, composition, 820 ohms, $\pm 10\%$, 1 W Electrical value adjusted at factory	24-820	B GB 8211
R37	Resistor: fixed, composition, 3,900 ohms, $\pm 10\%$, 1 W Electrical value adjusted at factory	24 3900	B GB 3921
R38	Resistor: fixed, composition, 10,000 ohms, $\pm 10\%$, 2 W	25-10K	B HB 1031
R39	Resistor: variable wirewound, 50 ohms, linear taper	210-2	HP
R40	Resistor: fixed, wirewound, 800 ohms, $\pm 10\%$, 10 W	26-6	S Type 1-3/4 E
R41	Resistor: fixed, wirewound, 15,000 ohms,	26 25	
R42	Resistor: fixed, composition, 3 megohms, $\pm 5\%$, 1/2 W	23 3M 5	B EB 3055
R43	Resistor: fixed, composition, 47,000 ohms, $\pm 10\%$, 1 W	24-47K	B GB 4731

*See "List of Manufacturers Code Letters For Replaceable Parts Table."

TABLE OF REPLACEABLE PARTS

Circuit Ref.	Description	-hp- Stock No.	Mfr. * & Mfrs. Designation
R44	Resistor: variable, 25,000 ohms, linear taper	210-11	HP
R45	Resistor: fixed, composition, 560,000 ohms, $\pm 10\%$, 1 W	24-560K	B GB 5641
R46	Resistor: fixed, composition, 22,000 ohms, $\pm 10\%$, 1 W	24-22K	B GB 2231
R47	Resistor: fixed, composition, 265,000 ohms, $\pm 1\%$, 1 W	31-265K	HP
R48	Resistor: fixed, composition, 265,000 ohms, $\pm 1\%$, 1 W	31-265K	HP
R49	Resistor: fixed, composition, 132,000 ohms, $\pm 1\%$, 1 W	31-132	HP
R50	Resistor: fixed, composition, 220,000 ohms, $\pm 10\%$, 1/2 W	23-220K	B EB 2241
R51	Resistor: fixed, composition, 33 ohms, $\pm 10\%$, 1 W	24-33	B GB 3301
R52	Resistor: fixed, composition, 15,000 ohms, $\pm 10\%$, 1 W	24-15K	B GB 1531
R53	Resistor: fixed, composition, 22,000 ohms, $\pm 10\%$, 1/2 W	23-22K	B EB 2231
R54	Resistor: fixed, composition, 680 ohms, $\pm 10\%$, 1 W	24-680	B GB 6811
R55	Resistor: fixed, composition, 220 ohms, $\pm 10\%$, 1 W Electrical value adjusted at factory	24-220	B GB 2211
R56	Resistor: fixed, composition, 100,000 ohms, $\pm 10\%$, 1 W	24-100K	B GB 1041
R57	Resistor: fixed, composition, 100,000 ohms, $\pm 10\%$, 1 W	24-100K	B GB 1041
J1	Connector: UG-185/U	125-UG185/ U	
F1	Fuse: A, 3 AG type	211-18	
	Fuseholder:	140-16	
	External Input Cable:	41A-16G	HP
	Indicator Light Assembly:	145-2	BB #807BS
	Input Attenuator:	41A-34	HP

*See "List of Manufacturers Code Letters For Replaceable Parts Table."

LIST OF CODE LETTERS USED IN TABLE OF REPLACEABLE PARTS TO DESIGNATE THE MANUFACTURERS

CODE LETTER	MANUFACTURER	ADDRESS	CODE LETTER	MANUFACTURER	ADDRESS
A	Aerovox Corp.	New Bedford, Mass.	AK	Hammerlund Mfg. Co., Inc.	New York 1, N. Y.
B	Allen-Bradley Co.	Milwaukee 4, Wis.	AL	Industrial Condenser Corp.	Chicago 18, Ill.
C	Amperite Co.	New York, N. Y.	AM	Insuline Corp. of America	Manchester, N. H.
D	Arrow, Hart & Hegeman	Hartford, Conn.	AN	Jennings Radio Mfg. Corp.	San Jose, Calif.
E	Bussman Manufacturing Co.	St. Louis, Mo.	AO	E. F. Johnson Co.	Waseca, Minn.
F	Carborundum Co.	Niagara Falls, N. Y.	AP	Lenz Electric Mfg. Co.	Chicago 47, Ill.
G	Centralab	Milwaukee 1, Wis.	AQ	Micro-Switch	Freeport, Ill.
H	Cinch-Jones Mfg. Co.	Chicago 24, Ill.	AR	Mechanical Industries Prod. Co.	Akron 8, Ohio
HP	Hewlett-Packard Co.	Palo Alto, Calif.	AS	Model Eng. & Mfg., Inc.	Huntington, Ind.
I	Clarostat Mfg. Co.	Dover, N. H.	AT	The Muter Co.	Chicago 5, Ill.
J	Cornell Dubilier Elec. Co.	South Plainfield, N. J.	AU	Ohmite Mfg. Co.	Skokie, Ill.
K	Hi-Q Division of Aerovox	Olean, N. Y.	AY	Resistance Products Co.	Harrisburg, Pa.
L	Erie Resistor Corp.	Erie 6, Pa.	AW	Radio Condenser Co.	Camden 3, N. J.
M	Fed. Telephone & Radio Corp.	Clifton, N. J.	AX	Shallcross Manufacturing Co.	Collingdale, Pa.
N	General Electric Co.	Schenectady 5, N. Y.	AY	Solar Manufacturing Co.	Los Angeles 58, Calif.
O	General Electric Supply Corp.	San Francisco, Calif.	AZ	Sealectro Corp.	New Rochelle, N. Y.
P	Girard-Hopkins	Oakland, Calif.	BA	Spencer Thermostat	Attleboro, Mass.
Q	Industrial Products Co.	Danbury, Conn.	BC	Stevens Manufacturing Co.	Mansfield, Ohio
R	International Resistance Co.	Philadelphia 8, Pa.	BD	Torrington Manufacturing Co.	Van Nuys, Calif.
S	Lectrohm Inc.	Chicago 20, Ill.	BE	Vector Electronic Co.	Los Angeles 65, Calif.
T	Littlefuse Inc.	Des Plaines, Ill.	BF	Weston Electrical Inst. Corp.	Newark 5, N. J.
U	Maguire Industries Inc.	Greenwich, Conn.	BG	Advance Electric & Relay Co.	Burbank, Calif.
V	Micamold Radio Corp.	Brooklyn 37, N. Y.	BH	E. I. DuPont	San Francisco, Calif.
W	Oak Manufacturing Co.	Chicago 10, Ill.	BI	Electronics Tube Corp.	Philadelphia 18, Pa.
X	P. R. Mallory Co., Inc.	Indianapolis, Ind.	BJ	Aircraft Radio Corp.	Boonton, N. J.
Y	Radio Corp. of America	Harrison, N. J.	BK	Allied Control Co., Inc.	New York 21, N. Y.
Z	Sangamo Electric Co.	Marion, Ill.	BL	Augat Brothers, Inc.	Attleboro, Mass.
AA	Sarkes Tarzian	Bloomington, Ind.	BM	Carter Radio Division	Chicago, Ill.
BB	Signal Indicator Co.	Brooklyn 37, N. Y.	BN	CBS Hytron Radio & Electric	Danvers, Mass.
CC	Sprague Electric Co.	North Adams, Mass.	BO	Chicago Telephone Supply	Elkhart, Ind.
DD	Stackpole Carbon Co.	St. Marys, Pa.	BP	Henry L. Crowley Co., Inc.	West Orange, N. J.
EE	Sylvania Electric Products Co.	Warren, Pa.	BQ	Curtiss-Wright Corp.	Carlstadt, N. J.
FF	Western Electric Co.	New York 5, N. Y.	BR	Allen B. Dumont Labs	Clifton, N. J.
GG	Wilkor Products, Inc.	Cleveland, Ohio	BS	Excel Transformer Co.	Oakland, Calif.
HH	Amphenol	Chicago 50, Ill.	BT	General Radio Co.	Cambridge 39, Mass.
II	Dial Light Co. of America	Brooklyn 37, N. Y.	BU	Hughes Aircraft Co.	Culver City, Calif.
JJ	Leecraft Manufacturing Co.	New York, N. Y.	BV	International Rectifier Corp.	El Segundo, Calif.
KK	Switchcraft, Inc.	Chicago 22, Ill.	BW	James Knights Co.	Sandwich, Ill.
LL	Gremar Manufacturing Co.	Wakefield, Mass.	BX	Mueller Electric Co.	Cleveland, Ohio
MM	Corad Corp.	Redwood City, Calif.	BY	Precision Thermometer & Inst. Co.	Philadelphia 30, Pa.
NN	Electra Manufacturing Co.	Kansas City, Mo.	BZ	Radio Essentials Inc.	Mt. Vernon, N. Y.
OO	Acro Manufacturing Co.	Columbus 16, Ohio	CA	Raytheon Manufacturing Co.	Newton, Mass.
PP	Alliance Manufacturing Co.	Alliance, Ohio	CB	Tung-Sol Lamp Works, Inc.	Newark 4, N. J.
QQ	Arco Electronics, Inc.	New York 13, N. Y.	CD	Varian Associates	Palo Alto, Calif.
RR	Astron Corp.	East Newark, N. J.	CE	Victory Engineering Corp.	Union, N. J.
SS	Axel Brothers Inc.	Long Island City, N. Y.	CF	Weckesser Co.	Chicago 39, Ill.
TT	Belden Manufacturing Co.	Chicago 44, Ill.	CG	Wilco Corporation	Indianapolis, Ind.
UU	Bird Electronics Corp.	Cleveland 14, Ohio	CH	Winchester Electronics, Inc.	Santa Monica, Calif.
VV	Barber Colman Co.	Rockford, Ill.	CI	Malco Tool & Die	Los Angeles 42, Calif.
WW	Bud Radio Inc.	Cleveland 3, Ohio	CJ	Oxford Electric Corp.	Chicago 15, Ill.
XX	Allen D. Cardwell Mfg. Co.	Plainville, Conn.	CK	Camloc-Fastener Corp.	Paramus, N. J.
YY	Cinema Engineering Co.	Burbank, Calif.	CL	George K. Garrett	Philadelphia 34, Pa.
ZZ	Any brand tube meeting RETMA standards.		CM	Union Switch & Signal	Swissvale, Pa.
AB	Corning Glass Works	Corning, N. Y.	CN	Radio Receptor	New York 11, N. Y.
AC	Dale Products, Inc.	Columbus, Neb.	CO	Automatic & Precision Mfg. Co.	Yonkers, N. Y.
AD	The Drake Mfg. Co.	Chicago 22, Ill.	CP	Bassick Co.	Bridgeport 2, Conn.
AE	Elco Corp.	Philadelphia 24, Pa.	CQ	Birnback Radio Co.	New York 13, N. Y.
AF	Hugh H. Eby Co.	Philadelphia 44, Pa.	CR	Fischer Specialties	Cincinnati 6, Ohio
AG	Thomas A. Edison, Inc.	West Orange, N. J.	CS	Telefunken (c/o MVM, Inc.)	New York, N. Y.
AH	Fonsteel Metallurgical Corp.	North Chicago, Ill.	CT	Potter-Burnfield Co.	Princeton, Ind.
AI	General Ceramics & Steatite Corp.	Keasbey, N. J.	CU	Cannon Electric Co.	Los Angeles, Calif.
AJ	The Guilemat Co.	Sunnyvale, Calif.	CV	Dynas, Inc.	Palo Alto, Calif.
			CW	Good-All Electric Mfg. Co.	Ogallala, Nebr.

CLAIM FOR DAMAGE IN SHIPMENT

The instrument should be tested as soon as it is received. If it fails to operate properly, or is damaged in any way, a claim should be filed with the carrier. A full report of the damage should be obtained by the claim agent, and this report should be forwarded to us. We will then advise you of the disposition to be made of the equipment and arrange for repair or replacement. Include model number and serial number when referring to this instrument for any reason.

WARRANTY

Hewlett-Packard Company warrants each instrument manufactured by them to be free from defects in material and workmanship. Our liability under this warranty is limited to servicing or adjusting any instrument returned to the factory for that purpose and to replace any defective parts thereof. Klystron tubes as well as other electron tubes, fuses and batteries are specifically excluded from any liability. This warranty is effective for one year after delivery to the original purchaser when the instrument is returned, transportation charges prepaid by the original purchaser, and when upon our examination it is disclosed to our satisfaction to be defective. If the fault has been caused by misuse or abnormal conditions of operation, repairs will be billed at cost. In this case, an estimate will be submitted before the work is started.

If any fault develops, the following steps should be taken:

1. Notify us, giving full details of the difficulty, and include the model number and serial number. On receipt of this information, we will give you service data or shipping instructions.
2. On receipt of shipping instructions, forward the instrument prepaid, to the factory or to the authorized repair station indicated on the instructions. If requested, an estimate of the charges will be made before the work begins provided the instrument is not covered by the warranty.

SHIPPING

All shipments of Hewlett-Packard instruments should be made via Truck or Railway Express. The instruments should be packed in a strong exterior container and surrounded by two or three inches of excelsior or similar shock-absorbing material.

DO NOT HESITATE TO CALL ON US

HEWLETT-PACKARD COMPANY

Laboratory Instruments for Speed and Accuracy

275 PAGE MILL ROAD

CABLE



PALO ALTO, CALIF. U.S.A.

"HEWPACK"