

# HP Archive

This vintage Hewlett Packard document was preserved  
and distributed by

**[www. hparchive.com](http://www.hparchive.com)**

Please visit us on the web !

On-line curator: Glenn Robb

This document is for FREE distribution only!

INSTRUCTION MANUAL CHANGE  
FOR

MODEL 202B

Serial 1674 and above

The following change has been made in the Model 202B  
since this manual was prepared.

Serial 1674 and above

Change C19 to:

Capacitor: fixed, electrolytic,  
40  $\mu$ f, 450 vdcw,  
-hp- no. 18-40  
Mfr. X, #FP-146

INSTRUCTION AND OPERATING MANUAL  
FOR

MODEL 202B  
LOW FREQUENCY OSCILLATOR  
Serial 1624 and Above

Copyright 1955 by Hewlett-Packard Company

The information contained in this booklet is intended for the operation and maintenance of Hewlett-Packard equipment and is not to be used otherwise or reproduced without the written consent of the Hewlett-Packard Company.

HEWLETT-PACKARD COMPANY  
395 PAGE MILL ROAD, PALO ALTO, CALIFORNIA, U.S.A.

TABLE OF CONTENTS

MODEL 202B

LOW FREQUENCY OSCILLATOR

	Page No.
General Description . . . . .	Frontispiece
Fig. 1. Model 202B Low Frequency Oscillator . . . . .	Frontispiece
Specifications . . . . .	1
Inspection . . . . .	3
Circuit Description . . . . .	5
Maintenance . . . . .	7
Fig. 2. Model 202B, Top Chassis View . . . . .	9
Fig. 3. Model 202B, Bottom Chassis View . . . . .	10
Fig. 4. Model 202B, Resistor Board Detail . . . . .	11
Trouble Shooting Chart . . . . .	12
Fig. 5. Model 202B, Range Switch Detail . . . . .	14
Schematic Diagram	
Table of Replaceable Parts . . . . .	15

### General Description

The Model 202B Low Frequency Oscillator is a practical, easy-to-use multi-purpose instrument for use throughout the 0.5 to 50,000 cps range. It has the precise accuracy and high stability associated with audio frequency measurement and has broad applicability for industrial, field and laboratory use. Applications include electrical simulation of mechanical phenomena, vibration or stability characteristics of mechanical systems, electrocardiograph and electro-encephalograph performance, seismograph response, vibration checks of structural components, performance of geophysical prospecting equipment, and general audio measurements.

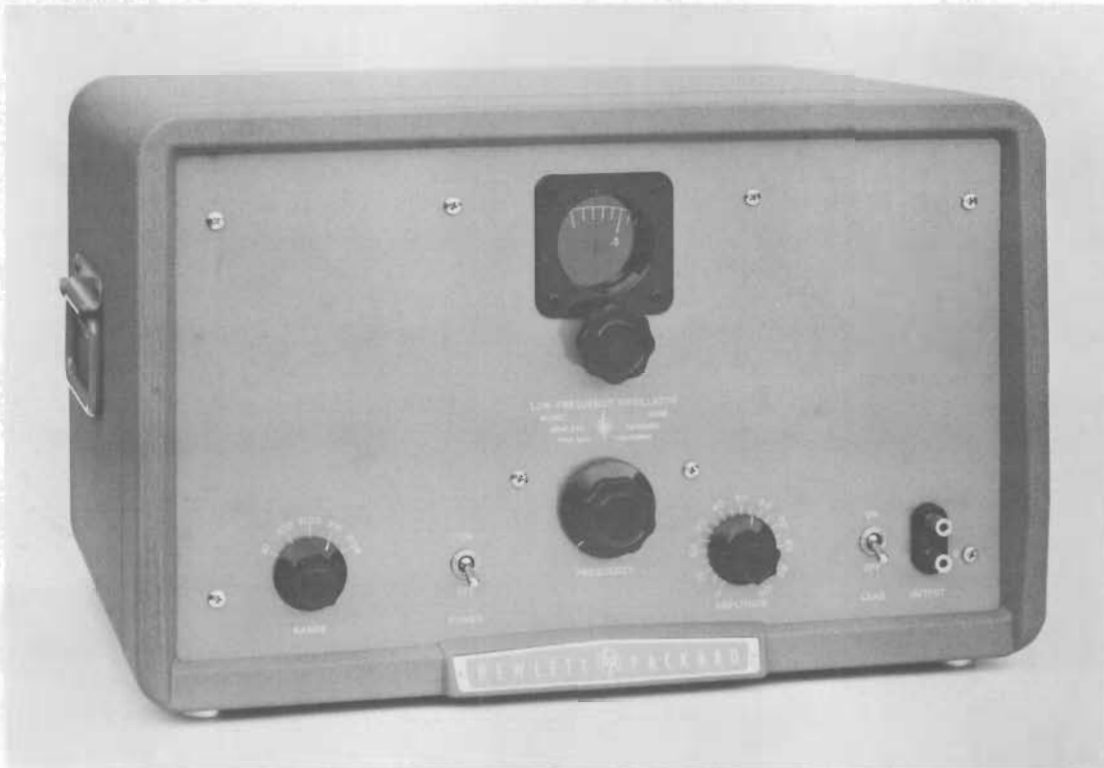

Fig. 1. Model 202B Low Frequency Oscillator

## INSTRUCTIONS

MODEL 202B

### LOW FREQUENCY OSCILLATOR

## SPECIFICATIONS

### Frequency Rating

Frequency Range: .5 to 50,000 cycles/sec.

Frequency Dial Calibration: .5 to 5

Range:	X1	0.5	to 5 cps.
	X10	5	to 50 cps.
	X100	50	to 500 cps.
	X1000	500	to 5,000 cps.
	X10,000	5,000	to 50,000 cps.

Calibration Accuracy:  $\pm 2\%$ .

Frequency Response:  $\pm 1$  db, 5 to 50,000 cps.  
 $\pm 2$  db, 0.5 to 5 cps.

Frequency Stability:  $\pm 2\%$  including warm-up drift.  
Less than  $\pm 1\%$  frequency change  
for line voltage changes of  $\pm 10$   
volts from 115 volts.

### Power Output Rating

Power Output: 100 milliwatts into rated load (10  
volts across 1000 ohms resistive  
load).

Distortion: Less than 1% of rated output from  
2 to 50,000 cps.

Hum: Less than 0.1% of rated output.

Load Impedance: 1000 ohms, resistive.

Internal Impedance: 25 ohms at 10 cps.

Power Supply Rating

Voltage: 115/230 volts  $\pm 10\%$ .

Frequency: 50 - 1000 cps.

Wattage: 95 watts.

Overall Dimensions

Cabinet Model: 20-3/4" wide x 12-1/2" high x  
14-3/4" deep.

Rack Model: 19" wide x 10-1/2" high x 14-1/4"  
deep.

Panel: 19" long x 10-1/2" high.

Depth Behind Panel: 13-1/4".

Weight

Cabinet Model: 43 pounds.

Rack Model: 36 pounds.

## OPERATING INSTRUCTIONS

### INSPECTION

This instrument has been thoroughly tested and inspected before being shipped and is ready for use when received.

After the instrument is unpacked, it should be carefully inspected for damage received in transit. If any shipping damage is found, follow the procedure outlined in the "Claim for Damage in Shipment" page at the back of this instruction book.

### CONTROLS AND TERMINALS

#### POWER

The toggle switch located on the lower left of the control panel controls the power supplied to the instrument from the power line.

#### FUSE

The fuseholder, located on the back of the chassis, contains a 1-1/2 ampere cartridge fuse. The fuse may be replaced by unscrewing the fuseholder cap and inserting a new fuse.

#### RANGE

This rotary switch inserts various range resistors in the frequency determining circuit of the oscillator. The position of this switch indicates the multiplying factor for the frequency dial calibration.

#### FREQUENCY DIAL

The frequency dial is calibrated directly in cycles per second for the lowest "X" range. It is controlled by a direct drive as well as a 6 to 1 vernier.

#### AMPLITUDE

This variable resistor controls the amplitude of the oscillator voltage admitted to the amplifier and, therefore, the output voltage of the instrument.

#### LOAD

This toggle switch located at the lower right of the control panel can be used to insert a 1,500 ohm resistance in parallel with the output load.



## OUTPUT

The two output terminals are located in the lower right corner of the control panel.

## POWER CABLE

The power cable consists of three conductors. Two of these conductors carry power to the instrument while the third conductor (green wire) is connected to the instrument chassis. The third wire projects from the cable near the plug end of the cable and may be connected to a ground when it is desirable to have a grounded instrument chassis.

## OPERATION

Plug the power cable of the Model 202B into a nominal 115 volt, 50 - 1000 cycle power source and turn on the power switch. The instrument will begin to operate as soon as the tubes have heated, but for maximum accuracy a warm-up period of about 30 minutes is necessary.

Set the frequency dial and RANGE switch so that their indications, when multiplied together, equal the desired frequency. For example, if it is desired to select an output frequency of 2,500 cycles per second, set the frequency dial to 2.5 and the RANGE switch to X1K.

Connect the oscillator OUTPUT binding posts to the equipment being driven and adjust the AMPLITUDE control for the desired output voltage.

Rated load for the Model 202B is 1000 ohms. It is important that the instrument be worked into loads no greater than 1500 ohms because a substantial dc voltage may build up across large load resistance.

If it is desired to work the instrument into high impedance loads, the LOAD switch at the lower right of the front panel should be turned on. This places a 1500 ohm resistor across the output terminals so that the instrument sees a load resistance consisting of the 1500 ohm resistor in parallel with the external load. The LOAD switch can be used with external loads as low as 3000 ohms to give a correct load for the instrument.

Usually, it is undesirable to work the instrument into loads less than 1000 ohms because an increase in distortion will result. However, no damage will be caused to the instrument by working into lower loads.

As the output voltage of the audio oscillator is reduced, the percentage of hum voltage will increase. At the lower levels this hum voltage becomes quite large, relative to the sine wave output voltage. This undesirable condition can be remedied by operating the audio oscillator at or slightly below rated output and inserting a suitable attenuator between the oscillator and the equipment being driven by the oscillator. The voltage divider circuit shown below is satisfactory for most applications.

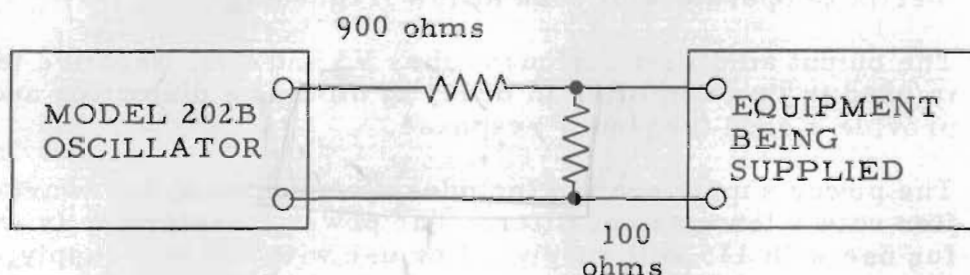

Other values of resistance may be used to obtain different voltage divisions. In all cases, the sum of the divider resistors should equal the rate load of 1000 ohms.

### CIRCUIT DESCRIPTION

The Model 202B Low Frequency Oscillator consists of an oscillator section, an amplifier section, and a power supply section.

The oscillator section (tubes V1 and V2) is a resistance tuned type circuit. Basically, this oscillator is a two-stage resistance-coupled amplifier which is caused to oscillate by the use of a positive feedback network. This network is a frequency-selective resistance-capacitance combination which controls the frequency of oscillation.

The feedback circuit is arranged so that the output of the second oscillator tube is fed through the network to the grid of the first tube. The entire system thus provides its own input in the proper phase relationship. Frequencies other than that to which the RC circuit is tuned are fed back out of phase for oscillation so that the oscillation is restricted to one frequency.

Negative feedback is used in the oscillator section in order to minimize distortion and to obtain a very high order of stability. The amount of negative feedback is determined by a resistance network one element of which is non-linear, namely, the three 10 watt lamps in the cathode of V1. The resistance of the lamps is a function of their temperature and increases with the current load. This lamp bank controls the amount of feedback in accordance with amplitude of oscillation and, consequently, maintains the amplitude of oscillation substantially constant over a wide frequency range. It is notable that the lamps have sufficient thermal inertia to operate well even at low frequencies.

The output amplifier includes tubes V3 and V9. Negative feedback is used in this amplifier in order to minimize distortion and to provide a good frequency response.

The power supply section includes a conventional full-wave rectifier with a low-pass pi filter. The power transformer is wired for use with 115 volt supply. For use with 230 volt supply, the transformer leads must be interchanged in accordance with transformer detail drawing on the general schematic diagram.

## MAINTENANCE

### COVER AND BOTTOM PLATE REMOVAL

The cover is removed by unscrewing the four screws which fasten the cover to the back of the instrument. The bottom plate is removed by unscrewing the four screws (one in each corner of the bottom plate) which fasten the plate to the chassis.

### TUBE REPLACEMENT

If the tubes are replaced in the regulator circuit, the regulated voltage should be measured at the cathode of V5 or V6 with an accurate high-impedance dc voltmeter. The regulated voltage should be approximately 225 volts dc and should be substantially constant for any line voltage between 105 and 125 volts. If necessary, R43, a screwdriver adjusted potentiometer located below the deck plate, should be adjusted to obtain the desired conditions.

After replacing any of the tubes (except the power rectifier), it will be desirable to measure the distortion in the output since a poor tube can cause excessive distortion without seemingly affecting the operation. The distortion should be less than 1% of the rated output. If replacement tubes are used which differ widely from their average type characteristics, it may be necessary to select a second replacement so that a tube of average characteristics is obtained.

### REPLACEMENT OF BALLAST LAMPS R21, R22, R23

The three 10 watt lamps R21, R22, and R23 are operated at a very low level, hence seldom, if ever, need replacing. However, should the lamp require changing, it will then be necessary with the new lamp in the circuit to check the ac voltage from the junction of C9 and C10 to ground. When the Model 202B is tuned to 1000 cps, the voltage should be within the range 22-26 volts as measured with a high-impedance ac vacuum tube voltmeter. If the voltage is not within this range, it may be corrected by adjusting R24.

### DISTORTION

Distortion may be caused by defective tubes, leakage through coupling capacitors, defective electrolytic capacitors, low dc supply voltage, or excessive output voltage from the oscillator section.

## DIAL DRIVE

A special wire cable driving arrangement is used in the Model 202B for rotating the oscillator section tuning capacitors. This driving system has a life beyond the life of the equipment. However, if any drive failure should occur, write to the factory for replacement cables and installation instructions. Refer to the Table of Replaceable Parts for the stock number.

## FREQUENCY CALIBRATION

If a change occurs in the frequency calibration, the instrument should be returned to the Hewlett-Packard Company for recalibration.

## EXCESSIVE DUST COLLECTION

X Precautions should be taken with the Model 202B to prevent excessive dust accumulation within the instrument. The frequency determining network in the instrument operates at an 85-megohm impedance level, and the presence of excessive dust may cause improper operation.

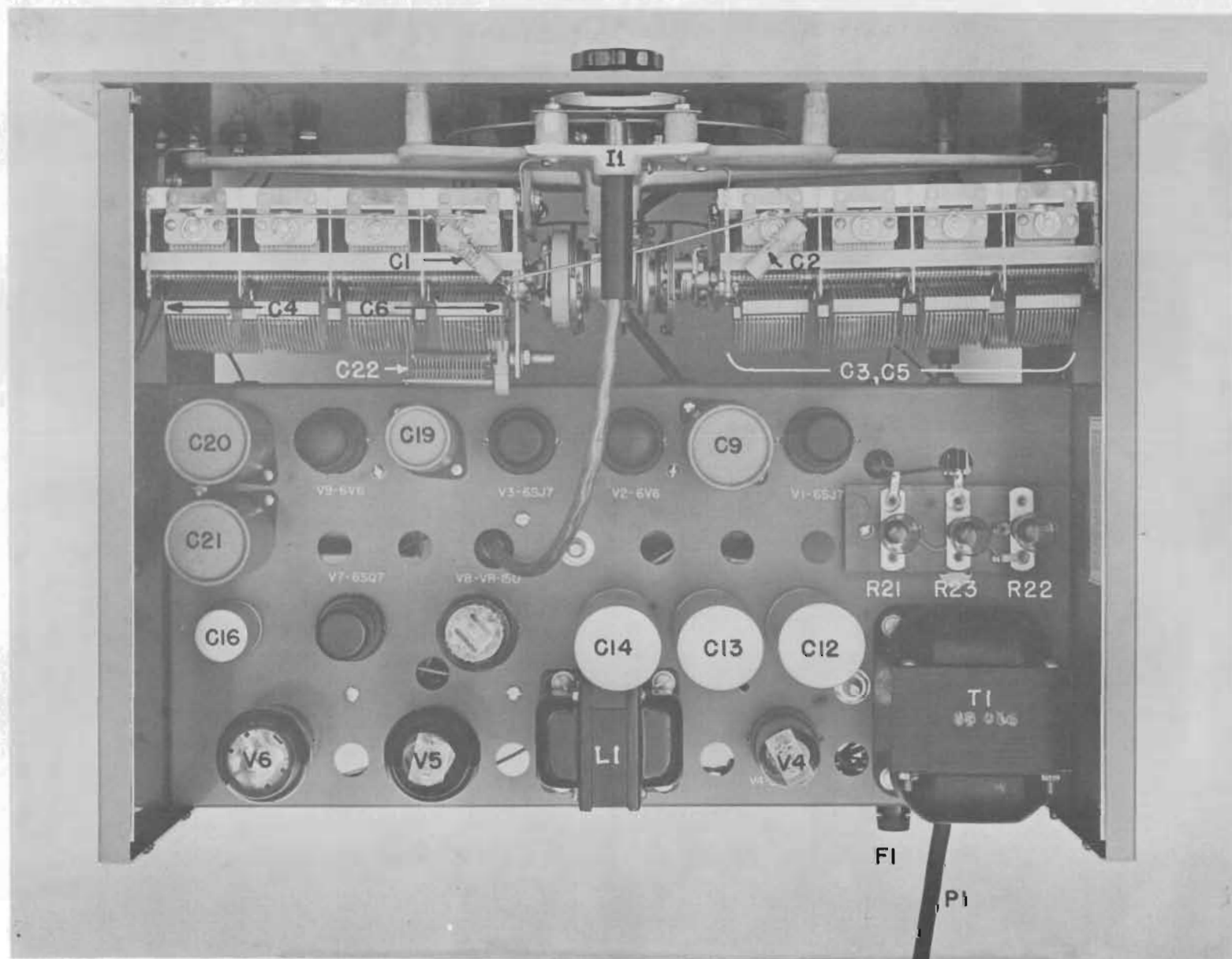

-6-

Fig. 2. Model 202B, Top Chassis View

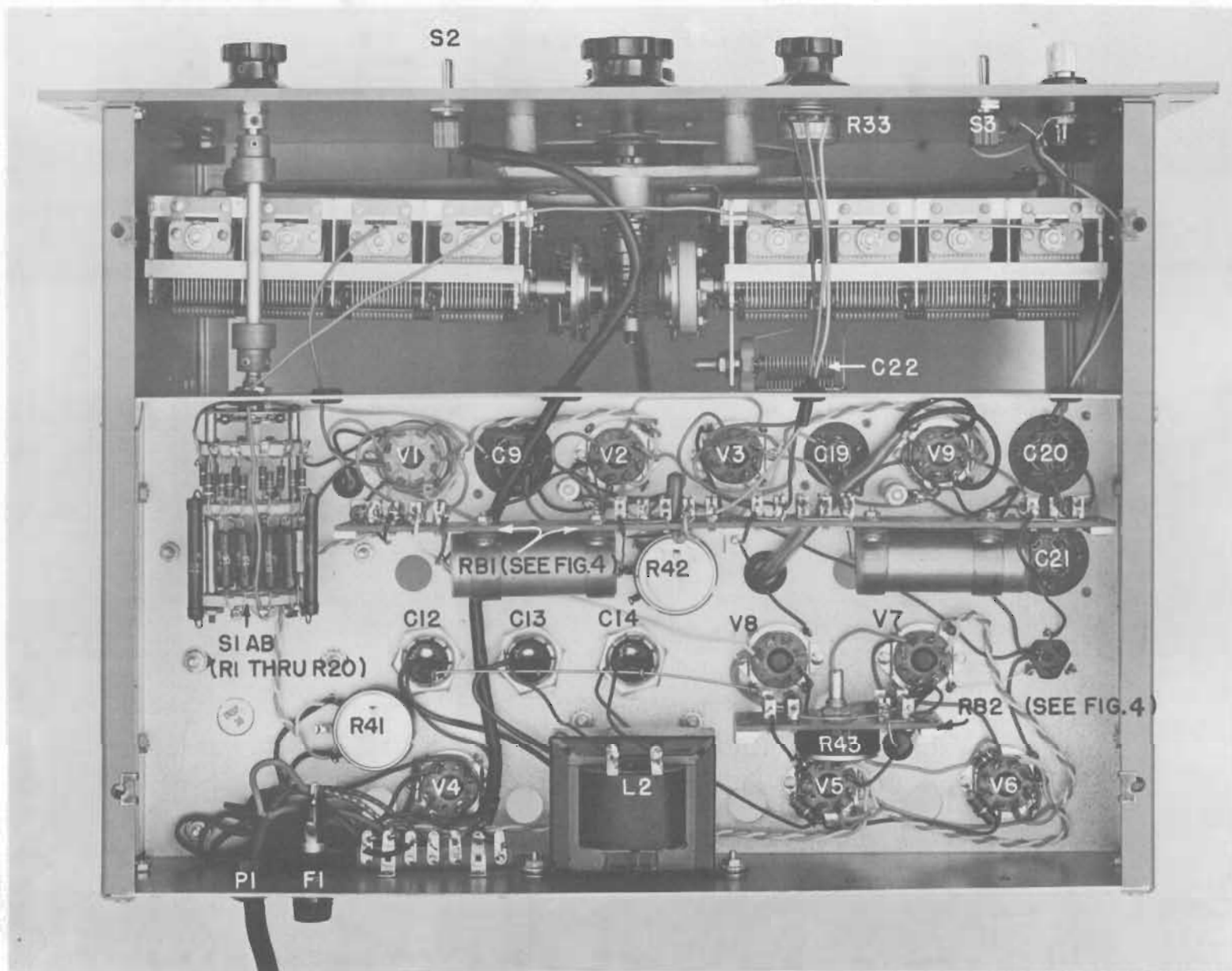

Fig. 3. Model 202B, Bottom Chassis View

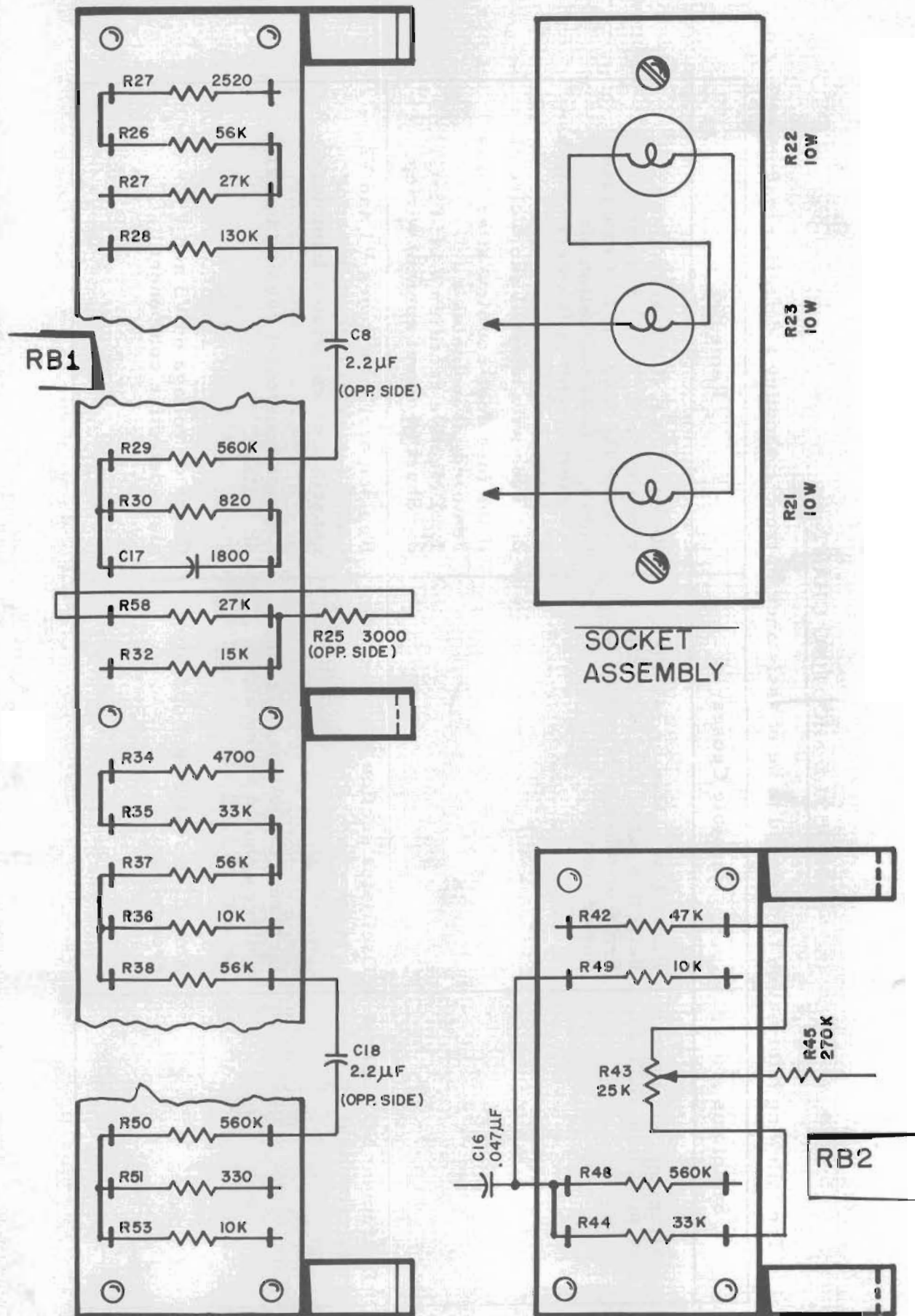

Fig. 4. Model 202B, Resistor Board Detail



### TROUBLE SHOOTING CHART

The following information is designed to be of assistance in trouble shooting a defective instrument:

Symptoms	Possible Causes	Remedies
Instrument NOT operating, pilot light NOT on.	Blown fuse. May be caused by defective fuse, shorted components or other overload on power supply.	Replace fuse; if this fuse blows, remove V4 (5Y3-GT) and again replace the fuse. If this new fuse blows, it is an indication of: <ol style="list-style-type: none"> <li>1. Short circuit in filament or transformer wiring.</li> <li>2. Tube with internal short circuit.</li> </ol> If the fuse does not blow after V4 is removed, it indicates a <ol style="list-style-type: none"> <li>1. Defective rectifier V4 (5Y3-GT).</li> <li>2. Short in direct current wiring.</li> </ol>
Instrument NOT operating, pilot light on.	Oscillator section not operating.  Incorrect dc voltage. These voltages should agree with schematic $\pm 10\%$ .  Amplifier section not operating properly.	Replace oscillator tubes V1 and V2. Check for short circuit in tuning capacitor or associated trimmers.  Replace component causing incorrect dc voltage.  Check dc voltage on V3 and V9. Replace defective component.

One or more frequency bands inoperative.	Dirty or bent contacts on range switch. Open range resistor.	Clean range switch (S1) contacts or replace range switch assembly if any of the resistors is defective.
Intermittent or jumpy output.	Short in trimmer capacitor C4 or in main tuning capacitor.	Use weak air jet or brush to clear foreign matter from plates of tuning capacitor.
Instrument operating high amount of distortion present in output.	<p>Incorrect dc voltages, defective regulator.</p> <p>Coupling capacitor defective (C8, C9, C18).</p> <p>Defective negative feedback capacitor C19.</p>	<p>Check power supply output voltage and output of regulated power supply.</p> <p>Check for high dc voltage on the grids of V2, V3, and V9. Replace the defective capacitor.</p> <p>Check dc voltage on pin 5 of V3. If more than +4 volts is present, remove connection between C19 and V3. If this returns the voltage on pin 5 of V3 to normal, it indicates that C19 is defective.</p>
Erratic AMPLITUDE control.	Defective variable resistor R33.	Check resistance between arm of R28 and ground for smooth variation with rotation of AMPLITUDE control. Replace R28, if necessary.

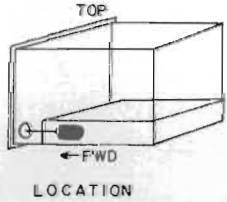
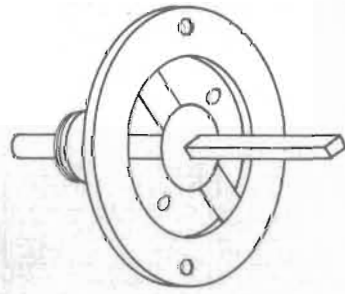
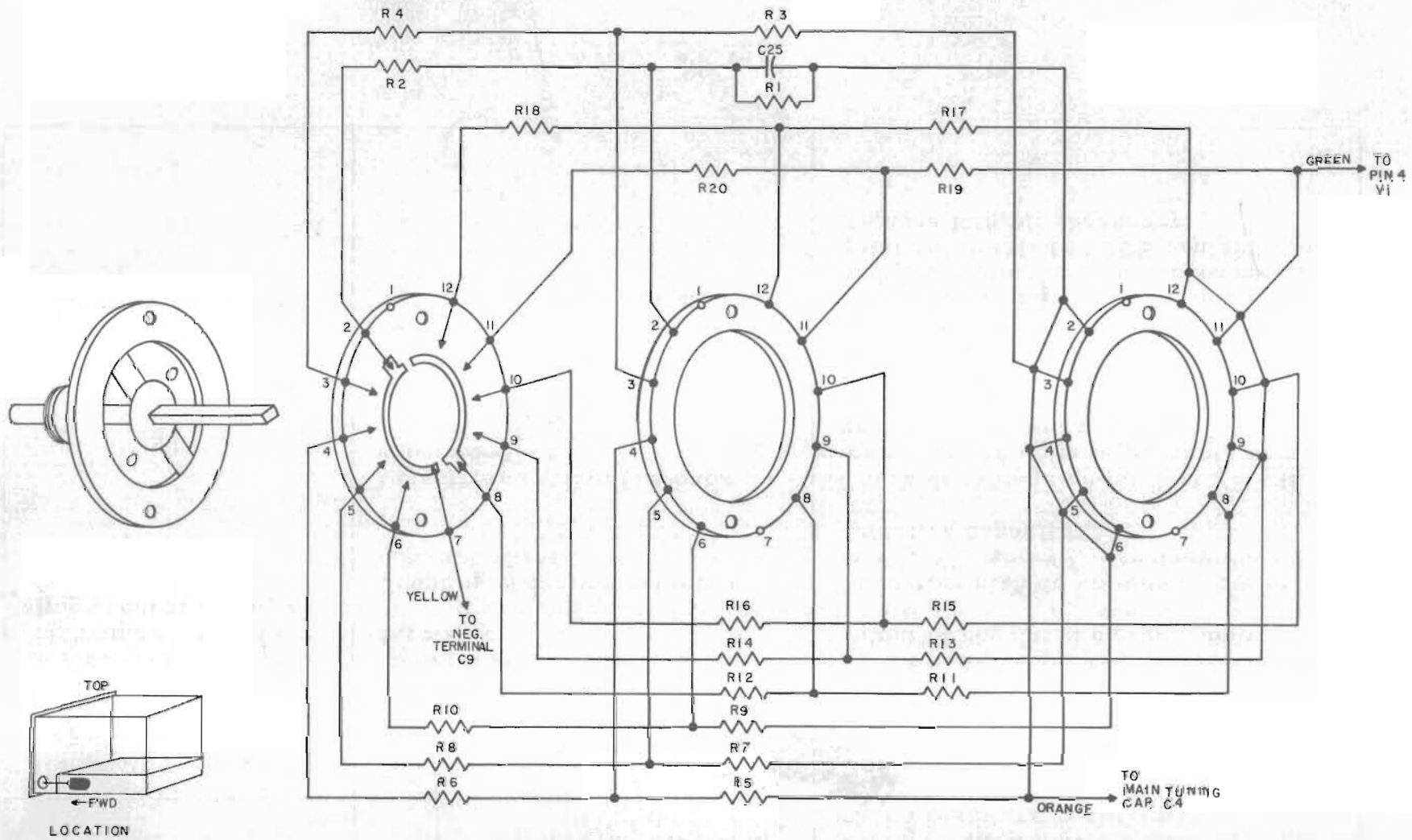
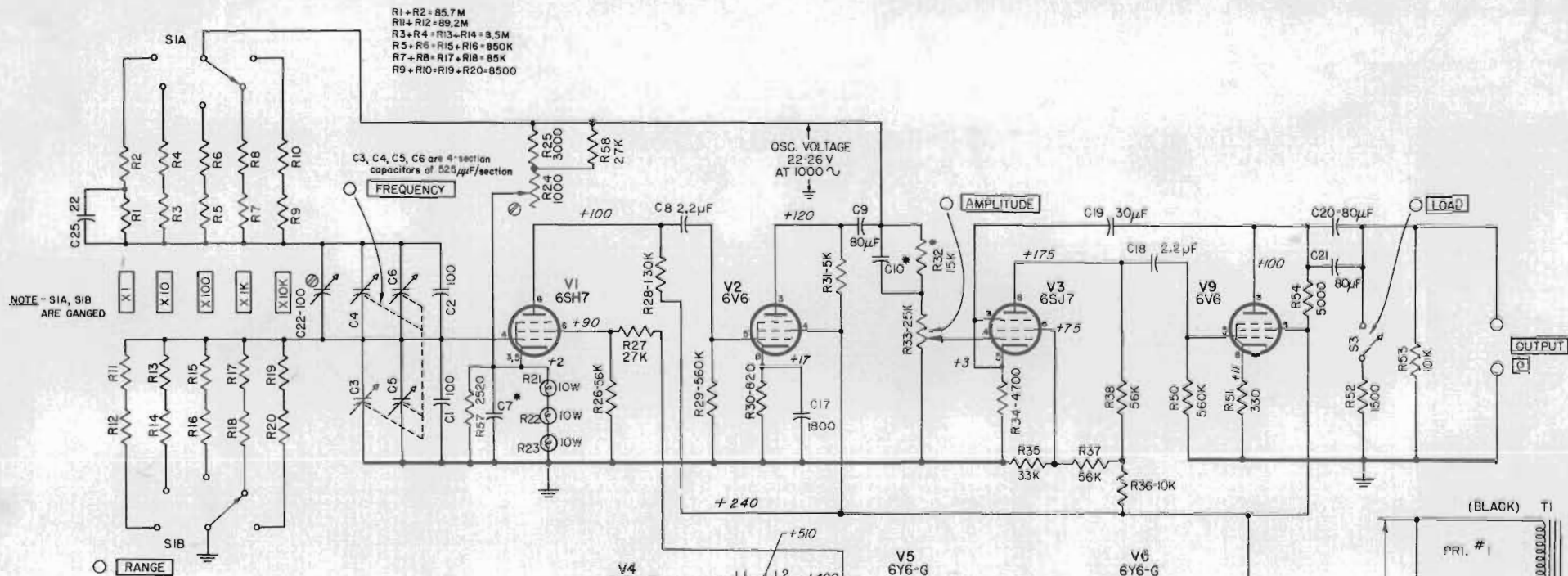

Fig. 5. Model 202B, Range Switch Detail



- NOTES
- CONDITIONS OF DC VOLTAGE MEASUREMENT:
- 115/230 VOLT, 50-60 $\text{C}$  POWER SUPPLY
  - MEASUREMENT TAKEN BETWEEN THE INDICATED POINTS AND CHASSIS WITH A VOLTMETER OF 122 MEGOHMS INPUT RESISTANCE.
  - SET S1AB AT X1K, FREQUENCY DIAL AT 1, R33 AT ZERO, S3 OPEN.

○ PANEL CONTROL

⊗ SCREWDRIVER ADJ.

⊕ CHASSIS

CAPACITANCE VALUES GIVEN IN  $\mu\text{F}$  UNLESS OTHERWISE NOTED.

K=1000 OHMS

M=1 MEGOHM

\*ELECTRICAL VALUE ADJUSTED AT THE FACTORY - PART MAY BE OMITTED.

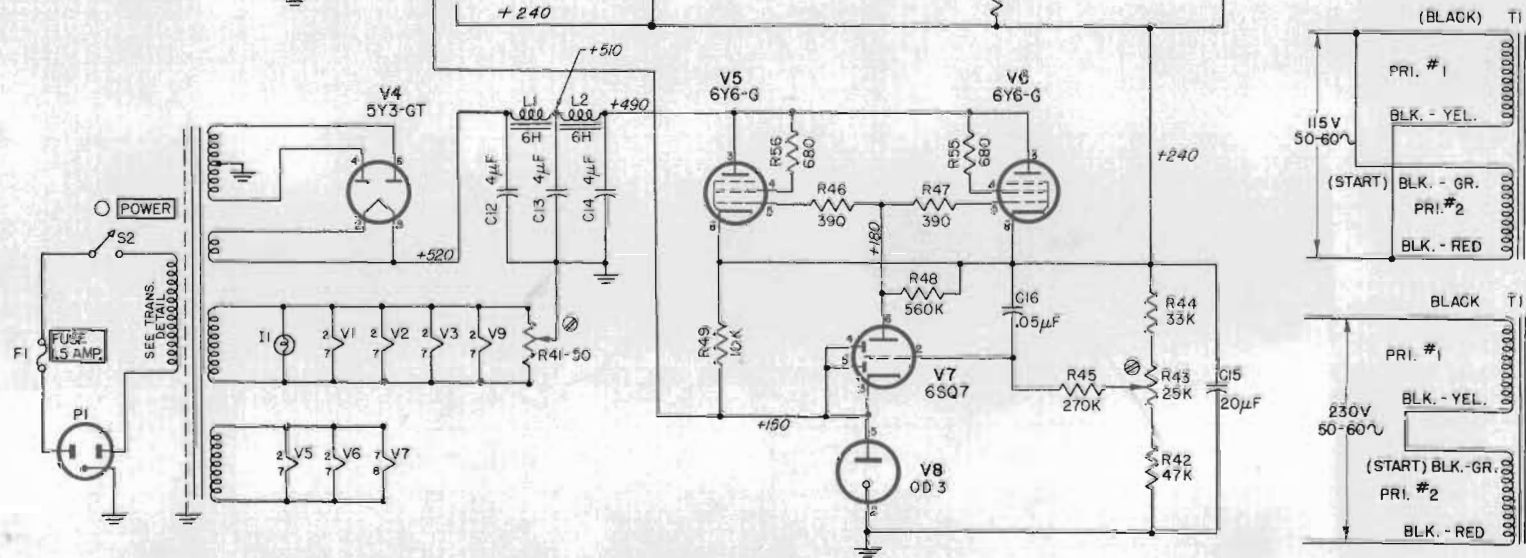

SCHEMATIC DIAGRAM OF MODEL 202B  
SERIAL 15498 ABOVE

TABLE OF REPLACEABLE PARTS

Circuit Ref.	Description	-hp- Stock No.	Mfr. * & Mfrs. Designation
C1	Capacitor: fixed, ceramic, 100 $\mu\text{mf}$ , $\pm 5\%$ , 500 vdcw	15-26	K
C2	Capacitor: fixed, ceramic, 100 $\mu\text{mf}$ , $\pm 5\%$ , 500 vdcw	15-26	K
C3	Capacitor: variable, air, 4 sections, 12.4 $\mu\text{mf}$ - 535 $\mu\text{mf}$ per section	12-7	W 1261A-4-60G
C4	Capacitor: variable, air, 4 sections, 12.4 $\mu\text{mf}$ - 535 $\mu\text{mf}$ per section	12-5	W 890D-4-60
C5	Capacitor: variable, air, 4 sections, 12.4 $\mu\text{mf}$ - 535 $\mu\text{mf}$ per section	12-7	W 1261A-4-60G
C6	Capacitor: variable, air, 4 sections, 12.4 $\mu\text{mf}$ - 535 $\mu\text{mf}$ per section	12-5	W 890D-4-60
C7	Capacitor: fixed, mica, Electrical value adjusted at the factory.		
C8	Capacitor: fixed, paper 2.2 $\mu\text{f}$ , $\pm 10\%$ , 400 vdcw	16-63	CC Type 38PS4
C9	Capacitor: fixed, electrolytic, 20, 20, 20, 20 $\mu\text{f}$ , 450 vdcw	18-42	X EP-444
C10	Capacitor: fixed, mica Electrical value adjusted at the factory.		
C11	This circuit reference not assigned.		
C12	Capacitor: fixed, oil filled paper, 4 $\mu\text{f}$ , $\pm 10\%$ , 600 vdcw	17-10	P T-64
C13	Capacitor: fixed, oil filled paper, 4 $\mu\text{f}$ , $\pm 10\%$ , 600 vdcw	17-10	P T-64
C14	Capacitor: fixed, oil filled paper, 4 $\mu\text{f}$ , $\pm 10\%$ , 600 vdcw	17-10	P T-64
C15	Capacitor: fixed, electrolytic, 20 $\mu\text{f}$ , 450 vdcw	18-20	X FP-144
C16	Capacitor: fixed, paper, .047 $\mu\text{f}$ , $\pm 10\%$ , 600 vdcw	16-15	CC 73P47396

\*See "List of Manufacturers Code Letters For Replaceable Parts Table."

202B 1/10/55 Serial 1624 and Above

TABLE OF REPLACEABLE PARTS

Circuit Ref.	Description	-hp- Stock No.	Mfr. * & Mfrs. Designation
C17	Capacitor: fixed, mica, 1800 $\mu\text{f}$ , $\pm 10\%$ , 300 vdcw	14-47	V Type OXM
C18	Capacitor: fixed, paper, 2.2 $\mu\text{f}$ , $\pm 10\%$ , 400 vdcw	16-63	CC Type 88PS4
C19	Capacitor: fixed, electrolytic, 10, 10, 10 $\mu\text{f}$ , 450 vdcw	18-31	X FP 375.8
C20	Capacitor: fixed, electrolytic, 20, 20, 20, 20 $\mu\text{f}$ , 450 vdcw	18-42	X EP 444
C21	Capacitor: fixed, electrolytic, 20, 20, 20, 20 $\mu\text{f}$ , 450 vdcw	18-42	X EP 444
C22	Capacitor: fixed, paper 1 $\mu\text{f}$ , $\pm 20\%$ , 400 vdcw	16-44	A Type P482
C23, C24	These circuit references not assigned.		
C25	Capacitor: fixed, ceramic, 22 $\mu\text{f}$ , $\pm 5\%$ , 500 vdcw	15-2	K C1-2
R1 through R20	Part of Range Switch Assembly		
R21	Lamp, incandescent 250v, 10W	211-29	O
R22	Lamp, incandescent 250v, 10W	211-29	O
R23	Lamp, incandescent 250v, 10W	211-29	O
R24	Resistor: variable, wirewound, 1000 ohms, 2W	210-5	I 43-1000
R25	Resistor: fixed, wirewound, 3000 ohms, $\pm 5\%$ , 1W	26-3000	R Type BW
R26	Resistor: fixed, composition, 56,000 ohms, $\pm 10\%$ , 1W	24-56K	B GB 5631
R27	Resistor: fixed, composition, 27,000 ohms, $\pm 10\%$ , 1W	24-27K	B GB 2731
R28	Resistor: fixed, composition, 130,000 ohms, $\pm 5\%$ , 1W	24-130K-5	B GB 1345

\*See "List of Manufacturers Code Letters For Replaceable Parts Table."

TABLE OF REPLACEABLE PARTS

Circuit Ref.	Description	-hp- Stock No.	Mfr. * & Mfrs. Designation
R29	Resistor: fixed, composition, 560,000 ohms, $\pm 10\%$ , 1W	24-560K	B GB 5641
R30	Resistor: fixed, composition, 820 ohms, $\pm 10\%$ , 1W	24-820	B GB 8211
R31	Resistor: fixed, wirewound, 5,000 ohms, $\pm 10\%$ , 10W	26-8	S Type 1-3/4E
R32	Resistor: fixed, composition Electrical value adjusted at factory.	24-15K	B GB 1531
R33	Resistor: variable, composition, 25,000 ohms, Linear taper	210-54	HP
R34	Resistor: fixed, composition, 4700 ohms, $\pm 10\%$ , 1W	24-4700	B GB 4721
R35	Resistor: fixed, composition, 33,000 ohms, $\pm 10\%$ , 1W	24-33K	B GB 3331
R36	Resistor: fixed, composition, 10,000 ohms, $\pm 10\%$ , 1W	24-10K	B GB 1031
R37	Resistor: fixed, composition, 56,000 ohms, $\pm 10\%$ , 1W	24-56K	B GB 5631
R38	Resistor: fixed, composition, 56,000 ohms, $\pm 10\%$ , 1W	24-56K	B GB 5631
R39, R40	These circuit references not assigned.		
R41	Resistor: variable, wirewound, 50 ohms, $\pm 10\%$ , 3W	210-2	G #21-010-067
R42	Resistor: fixed, composition, 47,000 ohms, $\pm 10\%$ , 1W	24-47K	B GB 4731
R43	Resistor: variable, composition, 25,000 ohms, $\pm 10\%$ , linear taper	210-54	HP
R44	Resistor: fixed, composition, 33,000 ohms, $\pm 10\%$ , 1W	24-33K	B GB 3331
R45	Resistor: fixed, composition, 270,000 ohms, $\pm 10\%$ , 1W	24-270K	B GB 2741
R46	Resistor: fixed, composition, 390 ohms, $\pm 10\%$ , 1/2W	23-390	B EB 3911
R47	Resistor: fixed, composition, 390 ohms, $\pm 10\%$ , 1/2W	23-390	B EB 3911

\*See "List of Manufacturers Code Letters For Replaceable Parts Table."

202B 1/10/55 Serial 1624 and Above

TABLE OF REPLACEABLE PARTS

Circuit Ref.	Description	-hp- Stock No.	Mfr. * & Mfrs. Designation
R48	Resistor: fixed, composition, 560,000 ohms, $\pm 10\%$ , 1W	24-560K	B GB 5641
R49	Resistor: fixed, composition, 10,000 ohms, $\pm 10\%$ , 2W	25-10K	B HB 1031
R50	Resistor: fixed, composition, 560,000 ohms, $\pm 10\%$ , 1W	24-560K	B GB 5641
R51	Resistor: fixed, composition, 330 ohms, $\pm 10\%$ , 2W	25-330	B HB 3311
R52	Resistor: fixed, composition, 1500 ohms, $\pm 10\%$ , 1W	24-1500	B GB 1521
R53	Resistor: fixed, composition, 10,000 ohms, $\pm 10\%$ , 1W	24-10K	B GB 1031
R54	Resistor: fixed, wirewound, 5000 ohms, $\pm 10\%$ , 10W	26-8	S Type 1-3/4E
R55	Resistor: fixed, composition, 680 ohms, $\pm 10\%$ , 1W	24-680	B GB 6811
R56	Resistor: fixed, composition, 680 ohms, $\pm 10\%$ , 1W	24-680	B GB 6811
R57	Resistor: fixed, composition, 2520 ohms, $\pm 1\%$	31-2520	Wilker Type CP-1
R58	Resistor: fixed, composition, 27,000 ohms, $\pm 10\%$ , 1W	24-27K	B GB 2731
L1	Reactor: 6h @ 125 ma, 240 ohms	911-47	HP
L2	Reactor: 6h @ 125 ma, 240 ohms	911-12	HP
S1A, B	Range, switch assembly: includes R1 through R20	22B-95B	HP
	Switch only	310-34	HP
S2, S3	Switch toggle: SPST	310-11	D, 20994
T1	Transformer, power	910-69	HP
	Knob (2): black bakelite, 1-1/2" dia	37-11	HP
	Knob: black bakelite, 1-5/8" dia	37-12	HP
	Knob: black bakelite, 2-1/16" dia	37-13	HP
	Fuseholder for 3 AG cartridge type fuse	140-18	HP

\*See "List of Manufacturers Code Letters For Replaceable Parts Table."



TABLE OF REPLACEABLE PARTS

Circuit Ref.	Description	-hp- Stock No.	Mfr. * & Mfrs. Designation
F1	Fuse: 1-1/2 amp, 250v	211-8	T 31201.5
	Terminals, post	149-4	HP
	Terminals, nut	149-5	HP
	Lamp holder	26A-33	HP
	Cable, lamp: 21"	812-40	Lenz, #4180
	Grommet, cable	39-29	HP
	Cable, toggle switch	22B-16	HP
	Cable, power	812-56	Essex
	Socket assembly: includes lamp holder resistor board, jumper	22B-52	HP
	Coupling, flexible, self-aligning	M25C	HP
	Coupling, flexible, self-aligning	M25G	HP
	Shaft, coupler	S2494-CR- 3-1/2	HP
V1	Tube: 6SH7	212-6SH7	ZZ
V2	Tube: 6V6	212-6V6	ZZ
V3	Tube: 6SJ7	212-6SJ7	ZZ
V4	Tube: 5Y3-GT	212-5Y3- GT	ZZ
V5	Tube: 6Y6-G	212-6Y6G	ZZ
V6	Tube: 6Y6-G	212-6Y6G	ZZ
V7	Tube: 6SQ7	212-6SQ7	ZZ
V8	Tube: VR 150	212-VR150	ZZ
	Mechanical Drive Cables	816-3-202B	HP
	Indicator, Dial	M-64	HP

\*See "List of Manufacturers Code Letters For Replaceable Parts Table."

202B 1/10/55 Serial 1624-and Above

LIST OF MANUFACTURERS CODE LETTERS  
FOR REPLACEABLE PARTS TABLE

<u>Code Letter</u>	<u>Manufacturer</u>
A	Aerovox Corp.
B	Allen-Bradley Co.
C	Amperite Co.
D	Arrow, Hart and Hegeman
E	Bussman Manufacturing Co.
F	Carborundum Co.
G	Centralab
H	Cinch Manufacturing Co.
HP	Hewlett-Packard
I	Clarostat Manufacturing Co.
J	Cornell Dubilier Electric Co.
K	Hi-Q Division of Aerovox Corp.
L	Erie Resistor Corp.
M	Federal Telephone and Radio Corp.
N	General Electric Co.
O	General Electric Supply Corp.
P	Girard-Hopkins
R	International Resistance Co.
S	Lectrohm, Inc.
T	Littelfuse, Inc.
V	Micamold Radio Corp.
X	P. R. Mallory Co., Inc.
Z	Sangamo Electric Co.
AA	Sarkes Tarzian
CC	Sprague Electric Co.
DD	Stackpole Carbon Co.
EE	Sylvania Electric Products, Inc.
FF	Western Electric Co.
HH	Amphenol
II	Dial Light Co. of America
KK	Switchcraft, Inc.
LL	Gremer Mfg. Co.
MM	Carad Corp.
ZZ	Any tube having RETMA standard characteristics

## CLAIM FOR DAMAGE IN SHIPMENT

The instrument should be tested as soon as it is received. If it fails to operate properly, or is damaged in any way, a claim should be filed with the carrier. A full report of the damage should be obtained by the claim agent, and this report should be forwarded to us. We will then advise you of the disposition to be made of the equipment and arrange for repair or replacement. Include model number, type number and serial number when referring to this instrument for any reason.

## WARRANTY

Hewlett-Packard Company warrants each instrument manufactured by them to be free from defects in material and workmanship. Our liability under this warranty is limited to servicing or adjusting any instrument returned to the factory for that purpose and to replace any defective parts thereof (except tubes, fuses and batteries). This warranty is effective for one year after delivery to the original purchaser when the instrument is returned, transportation charges prepaid by the original purchaser, and which upon our examination is disclosed to our satisfaction to be defective. If the fault has been caused by misuse or abnormal conditions of operation, repairs will be billed at cost. In this case, an estimate will be submitted before the work is started.

If any fault develops, the following steps should be taken:

1. Notify us, giving full details of the difficulty, and include the model number, type number and serial number. On receipt of this information, we will give you service instruction or shipping data.

2. On receipt of shipping instruction, forward the instrument prepaid, and repairs will be made at the factory. If requested, an estimate of the charges will be made before the work begins provided the instrument is not covered by the warranty.

## SHIPPING

All shipments of Hewlett-Packard instruments should be made via Railway Express. The instruments should be packed in a wooden box and surrounded by two to three inches of excelsior or similar shock-absorbing material.

DO NOT HESITATE TO CALL ON US

HEWLETT-PACKARD COMPANY

*Laboratory Instruments for Speed and Accuracy*

395 PAGE MILL ROAD



PALO ALTO, CALIFORNIA