

# HP Archive

This vintage Hewlett Packard document was preserved  
and distributed by

**[www. hparchive.com](http://www.hparchive.com)**

Please visit us on the web !

On-line curator: Gertjan Rhebergen

# DUAL CHANNEL VERTICAL AMPLIFIER

## 1805A

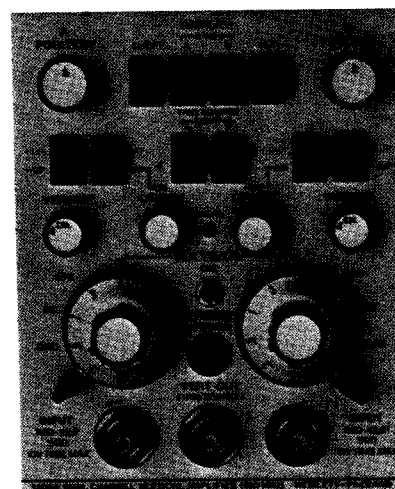

## **CERTIFICATION**

*The Hewlett-Packard Company certifies that this instrument was thoroughly tested and inspected and found to meet its published specifications when it was shipped from the factory. The Hewlett-Packard Company further certifies that its calibration measurements are traceable to the U.S. National Bureau of Standards to the extent allowed by the Bureau's calibration facility.*

## **WARRANTY AND ASSISTANCE**

This Hewlett-Packard product is warranted against defects in materials and workmanship. This warranty applies for one year from the date of delivery, or, in the case of certain major components listed in the operating manual, for the specified period. We will repair or replace products which prove to be defective during the warranty period provided they are returned to Hewlett-Packard. No other warranty is expressed or implied. We are not liable for consequential damages.

Service contracts or customer assistance agreements are available for Hewlett-Packard products that require maintenance and repair on-site.



OPERATING AND SERVICE MANUAL

**DUAL CHANNEL VERTICAL AMPLIFIER  
MODEL 1805A  
(Including Option 003)**

SERIAL NUMBERS

This manual applies directly to instruments with serial numbers prefixed 1513A.

With changes described in Section VII, this manual also applies to instruments with serial numbers prefixed 1205A through 1409A.

HEWLETT-PACKARD COMPANY/COLORADO SPRINGS DIVISION  
1900 GARDEN OF THE GODS ROAD, COLORADO SPRINGS, COLORADO, U.S.A.

Manual Part Number 01805-90902  
Microfiche Part Number 01805-90802

PRINTED: DEC 1975

## **SAFETY SUMMARY**

*The following general safety precautions must be observed during all phases of operation, service, and repair of this instrument. Failure to comply with these precautions or with specific warnings elsewhere in this manual violates safety standards of design, manufacture, and intended use of the instrument. Hewlett-Packard Company assumes no liability for the customer's failure to comply with these requirements.*

### **GROUND THE INSTRUMENT.**

*To minimize shock hazard, the instrument chassis and cabinet must be connected to an electrical ground. The instrument is equipped with a three-conductor ac power cable. The power cable must either be plugged into an approved three-contact electrical outlet or used with a three-contact to two-contact adapter with the grounding wire (green) firmly connected to an electrical ground (safety ground) at the power outlet. The power jack and mating plug of the power cable meet International Electrotechnical Commission (IEC) safety standards.*

### **DO NOT OPERATE IN AN EXPLOSIVE ATMOSPHERE.**

*Do not operate the instrument in the presence of flammable gases or fumes. Operation of any electrical instrument in such an environment constitutes a definite safety hazard.*

### **KEEP AWAY FROM LIVE CIRCUITS.**

*Operating personnel must not remove instrument covers. Component replacement and internal adjustments must be made by qualified maintenance personnel. Do not replace components with power cable connected. Under certain conditions, dangerous voltages may exist even with the power cable removed. To avoid injuries, always disconnect power and discharge circuits before touching them.*

### **DO NOT SERVICE OR ADJUST ALONE.**

*Do not attempt internal service or adjustment unless another person, capable of rendering first aid and resuscitation, is present.*

### **DO NOT SUBSTITUTE PARTS OR MODIFY INSTRUMENT.**

*Because of the danger of introducing additional hazards, do not install substitute parts or perform any unauthorized modification to the instrument. Return the instrument to a Hewlett-Packard Sales and Service Office for service and repair to ensure that safety features are maintained.*

### **DANGEROUS PROCEDURE WARNINGS.**

*Warnings, such as the example below, precede potentially dangerous procedures throughout this manual. Instructions contained in the warnings must be followed.*

**WARNING**

*Dangerous voltages, capable of causing death, are present in this instrument.  
Use extreme caution when handling, testing, and adjusting.*

## TABLE OF CONTENTS

Section	Page	Section	Page
<b>I</b>	<b>GENERAL INFORMATION</b> .....	<b>V</b>	<b>PERFORMANCE CHECK AND ADJUSTMENTS</b> .....
	1-1		5-1
1-1.	Introduction .....	5-1.	Introduction .....
	1-1		5-1
1-5.	Specifications .....	5-3.	Equipment Required .....
	1-1		5-1
1-7.	Accessories Supplied .....	5-5.	Performance Checks .....
	1-1		5-1
1-9.	Accessories Available .....	5-7.	Adjustments .....
	1-1		5-1
1-11.	Options .....	5-9.	Performance Check Record .....
	1-1		5-1
1-12.	Option 003 .....	5-11.	Front-panel Control Settings .....
	1-1		5-1
1-13.	Instrument and Manual Identification .....	5-13.	Performance Check Procedures .....
	1-1		5-2
<b>II</b>	<b>INSTALLATION</b> .....	5-14.	Initial Performance Check .....
	2-1		5-2
2-1.	Introduction .....	5-15.	Polarity Check .....
	2-1		5-2
2-3.	Initial Inspection .....	5-17.	Deflection Factor .....
	2-1		5-2
2-5.	Preparation for Use .....	5-19.	DC Offset Voltage .....
	2-1		5-3
2-8.	Repacking for shipment .....	5-21.	Rise Time .....
	2-1		5-3
<b>III</b>	<b>OPERATION</b> .....	5-23.	Bandwidth Check .....
	3-1		5-4
3-1.	Introduction .....	5-25.	Common Mode Rejection .....
	3-1		5-4
3-3.	Instrument Capabilities .....	5-27.	Vertical Output Amplitude .....
	3-1		5-5
3-6.	General Operating Instructions .....	5-29.	Vertical Output Bandwidth .....
	3-1		5-5
3-7.	Controls and Connectors .....	5-31.	Triggering .....
	3-1		5-6
3-8.	Initial Turn-on Procedure .....	5-33.	VSWR Check .....
	3-1		5-6
3-9.	Amplifier Calibration .....	5-35.	Adjustments .....
	3-1		5-7
3-10.	Application Procedures .....	5-37.	DC Balance Adjustment .....
	3-1		5-7
3-11.	Peak-to-peak Voltage Measurements .....	5-38.	Sync Balance Adjustment .....
	3-1		5-7
3-12.	DC Voltage Measurements .....	5-39.	Sync Level Adjustment .....
	3-1		5-7
3-13.	Time-interval Measurements .....	5-40.	Vert Out Level Adjustment .....
	3-3		5-7
3-14.	Frequency Calculation .....	5-41.	Volts/Div Cal Adjustment .....
	3-3		5-9
3-15.	Probe Compensation .....	5-42.	Attenuator Adjustments .....
	3-3		5-9
<b>IV</b>	<b>PRINCIPLES OF OPERATION</b> .....	5-43.	Pulse Response Adjustments .....
	4-1		5-10
4-1.	Introduction .....	<b>VI</b>	<b>REPLACEABLE PARTS</b> .....
	4-1		6-1
4-3.	Block Diagram .....	6-1.	Introduction .....
	4-1		6-1
4-5.	Attenuator .....	6-3.	Ordering Information .....
	4-1		6-1
4-6.	Impedance Converter .....	<b>VII</b>	<b>MANUAL CHANGES</b> .....
	4-1		7-1
4-7.	Preamplifier .....	7-1.	Introduction .....
	4-1		7-1
4-8.	Channel A Control .....	7-3.	Manual Changes .....
	4-1		7-1
4-9.	Sync Amplifier .....	7-5.	Manual Change Instructions .....
	4-1		7-1
4-11.	Delay Line .....	<b>VIII</b>	<b>SCHEMATICS AND TROUBLE-SHOOTING</b> .....
	4-1		8-1
4-12.	Main Amplifier .....	8-1.	Introduction .....
	4-1		8-1
4-13.	Output Amplifier .....	8-3.	Schematics .....
	4-1		8-1
4-14.	Control Circuit .....	8-8.	Repair and Replacement .....
	4-1		8-1
4-19.	Power Supply .....	8-10.	Output Transistor Removal .....
	4-2		8-1
4-21.	Detailed Circuitry .....	8-11.	Attenuator Removal .....
	4-2		8-1
4-23.	Attenuators A10 and A11 .....	8-12.	Attenuator Repair .....
	4-2		8-1
4-28.	Preamplifier .....	8-16.	Circuit Boards .....
	4-2		8-2
4-35.	Delay Line .....	8-17.	Board Connections .....
	4-2		8-2
4-36.	Main Amplifier .....	8-18.	Circuit Board Removal .....
	4-2		8-2
4-37.	Output Amplifier .....	8-27.	Semiconductor Replacement .....
	4-3		8-3
4-38.	Sync Amplifier .....	8-28.	Integrated Circuit Replacement .....
	4-3		8-3
		8-29.	Troubleshooting .....
			8-3

**LIST OF ILLUSTRATIONS**

Figure	Title	Page	Figure	Title	Page
2-1.	Plug-in Mating .....	2-2	8-7.	Preamplifier and Sync Amplifier Schematic 2 .....	8-10
3-1.	Controls and Connectors .....	3-2	8-8.	Interconnecting Board A4, Component Identification .....	8-12
3-2.	Divider Probe Adjustment Display .....	3-4	8-9.	Preamplifier and Sync Amplifier Schematic 3 .....	8-12
5-1.	Polarity Check Test Setup .....	5-2	8-10.	Main Amplifier Board A7, Component Identification .....	8-14
5-2.	Deflection Factor Test Setup .....	5-3	8-11.	Output Amplifier Board A8, Component Identification .....	8-14
5-3.	Rise Time Test Setup .....	5-3	8-12.	Output Amplifier Schematic 4 .....	8-14
5-4.	Bandwidth Test Setup .....	5-4	8-13.	Top Switched Board A1, Component Identification .....	8-16
5-5.	CMR Test Setup .....	5-4	8-14.	Top Switch Board Schematic 5 .....	8-17
5-6.	Vertical Output Amplitude Test Setup .....	5-5	8-15.	Bottom Switch Board A2, Component Identification .....	8-18
5-7.	Vertical Output Bandwidth Test Setup .....	5-5	8-16.	Bottom Switch Board Schematic 6 .....	8-19
5-8.	VSWR Test Setup .....	5-6	8-17.	Control Board A3, Component Identification .....	8-20
5-9.	Adjustment Locations .....	5-8	8-18.	Control Board Schematic 7 .....	8-20
8-1.	Attenuator Assembly .....	8-2	8-19.	Power Supply Board A5, Component Identification .....	8-22
8-2.	Chassis Component and Assembly Locations .....	8-4	8-20.	Power Supply Schematic 8 .....	8-23
8-3.	Troubleshooting Block Diagram .....	8-6			
8-4.	Attenuator Component Identification .....	8-8			
8-5.	Attenuator Schematic 1 .....	8-9			
8-6.	Preamplifier and Sync Amplifier Board A6, Component Identification .....	8-10			

**LIST OF TABLES**

Table	Title	Page	Table	Title	Page
1-1.	Specifications .....	1-2	5-10.	Channel B Pulse Response Adjustments .....	5-10
5-1.	Recommended Test Equipment .....	5-0		Performance Check Records .....	5-11
5-2.	Deflection Factor Accuracy .....	5-3	6-1.	Abbreviations for Replaceable Parts List .....	6-1
5-3.	Triggering .....	5-6	6-2.	Replaceable Parts .....	6-2
5-4.	VSWR .....	5-7	6-3.	List of Manufacturers' Codes .....	6-9
5-5.	Compensation Adjustments .....	5-9	7-1.	Manual Changes .....	7-1
5-6.	Attenuator Input Adjustments .....	5-10			
5-7.	Compensation Adjustment .....	5-10			
5-8.	Attenuator Input Adjustment .....	5-10			
5-9.	Channel A Pulse Response Adjustments .....	5-10			

## SECTION I

### GENERAL INFORMATION

#### 1-1. INTRODUCTION.

1-2. The Hewlett-Packard Model 1805A plug-in is a dual-channel vertical amplifier designed to operate with a horizontal time base in an HP 180-series oscilloscope mainframe. Each channel provides accurate measurements of high-frequency signals and fast rise time pulses with 5 mV/div vertical deflection capability over the full 100-MHz bandwidth. Selectable input impedance of either 50 ohms or 1 megohm permits impedance selection that best meets measurement applications. Its low shunt capacitance of approximately 13 pF reduces phase shift and signal loss in pulse or cw measurements. In addition, the dc offset capability of  $\pm 200$  divisions allows low-level, biased logic pulses to be positioned on screen for accurate measurements.

1-3. This manual contains installation and operating instructions, as well as maintenance information for the 1805A. Instrument specification and procedures for verifying proper operation are included. Procedures are also included for adjusting the instrument to its performance specifications. Schematic diagrams, the theory of operation, and troubleshooting information are provided for use in maintaining the instrument.

1-4. This section of the manual contains the performance specifications for the 1805A, and a list of available options. It also lists the accessories that are available. Instrument and manual identification information are also included.

#### 1-5. SPECIFICATIONS.

1-6. Table 1-1 is a complete list of the 1805A critical specifications that are controlled by tolerances. Any changes in specifications due to manufacturing, design, or traceability to the U.S. National Bureau of Standards will be listed on a manual change sheet included with this manual. The manual and manual change sheet supersede all previous information concerning specifications of the 1805A.

#### 1-7. ACCESSORIES SUPPLIED.

1-8. The following accessories are supplied with the 1805A:

Two Voltage Divider Probes, HP Model 10014A

#### 1-9. ACCESSORIES AVAILABLE.

1-10. The following accessories are available for the 1805A:

Model 10016A Voltage Divider Probes  
Model 10020A Resistive Divider Probe Kit  
Model 1120A 500 MHz Active Probe  
Model 1125A Impedance Converter Probe

#### 1-11. OPTIONS.

1-12. **OPTION 003.** This option provides the basic instrument without the two HP Model 10014A Voltage Divider Probes.

#### 1-13. INSTRUMENT AND MANUAL IDENTIFICATION.

1-14. Instrument identification by serial number is located on the rear panel. Hewlett-Packard uses a two-section serial number consisting of a four-digit prefix and a five-digit suffix, separated by a letter designating the country in which the instrument was manufactured. (A=U.S.A.; G=West Germany; J=Japan; U=United Kingdom.)

1-15. This manual applies to instruments with a serial prefix number as shown on the title page. If changes have been made in the instrument since this manual was printed, a "Manual Changes" supplement supplied with the manual will define these changes. Be sure to record these changes in your manual. Backdating information in Section VII adapts the manual to instruments with serial numbers lower than that shown on the title page. Part numbers for the manual and the microfiche copy of the manual are also shown on the title page.



Table 1-1. Specifications

**MODES OF OPERATION**

Channel A; channel B; channels A and B displayed alternately on successive sweeps (ALT); channel A and B displayed by switching between channels at approx 400 kHz rate (CHOP) with blanking during switching; channel A plus channel B (algebraic addition).

**EACH CHANNEL (2)**

**BANDWIDTH:** (measured with or without 10014A probe, 3 dB down from 8 div reference signal from a terminated 50-ohm source.)

**DC-coupled:** dc to 100 MHz.

**AC-coupled:** approx 10 Hz to 100 MHz (lower limit is approx 1 Hz with 10014A probe).

**RISE TIME:** <3.5 ns (measured with or without 10014A probes, 10% to 90% points of 6 div input step from a terminated 50-ohm source).

**DEFLECTION FACTOR**

**Ranges:** 5 mV/div to 5 V/div (10 calibrated positions) in 1, 2, 5 sequence. ±2% attenuator accuracy.

**Vernier:** provides continuous adjustment between deflection factor settings and extends maximum deflection factor to at least 12.5 V/div. Front panel light indicates when vernier is not in CAL position.

**POLARITY:** + or — up, selectable.

**SIGNAL DELAY:** input signals are delayed sufficiently to view leading edge of input pulse without advanced trigger.

**INPUT COUPLING:** AC, DC, 50 ohms (dc), or ground. Ground position disconnects input connector and grounds amplifier input.

**INPUT RC**

**AC and DC:** 1 megohm ±1% shunted by approx 13 pF. Constant on all ranges.

**50 ohm:** 50 ohms ±2%. VSWR <1.2:1 at 100 MHz on all ranges.

**MAXIMUM INPUT**

**AC and DC:** ±300 V (dc + peak ac) at 1 kHz or less. ±150 V (dc + peak ac) on 5 mV/div range at 1 kHz or less.

**50 ohm:** 10 V rms.

**DYNAMIC RANGE:** 6 div at 100 MHz increasing to 16 div at ≤15 MHz.

**POSITIONING RANGE:** 16 div.

**A+B OPERATION**

**Amplifier:** bandwidth and deflection factors are unchanged; either channel may be inverted for ±A ±B operation.

**Differential Input (A—B) Common Mode:** CMRR is at least 40 dB from dc to 1 MHz for common mode signals of 16 div or less. CMRR is at least 20 dB at 50 MHz for common mode signals of 6 div or less.

**TRIGGERING**

**SOURCE:** selectable from channel A, channel B or a composite (Comp) signal from A and B in any display mode. Composite is channels A and B signals switched for Alt and Chop modes and added for A and B mode. Vernier and position controls do not affect A, B, or composite trigger signals. A and B signals are independent of polarity selection.

**FREQUENCY**

Time Base Plug-in	Trigger Frequency*	Required Vertical Deflection
1820C, 1824A	dc - 50 MHz	1/2 div
1825A, 1840A, 1841A	dc - 100 MHz	1 div
1820B, 1822A	dc - 50 MHz	1/2 div
	dc - 100 MHz	2 div
1820A, 1821A	dc - 50 MHz	1 div

\*All display modes except Chop, dc to 100 kHz in Chop.

**OFFSET**

±200 div of offset. Allows offset of dc or ac signals up to the dynamic range and maximum input.

**VERTICAL SIGNAL OUTPUT (selected by trigger source switch)**

**Bandwidth:** >50 MHz into 50 ohms.

**Amplitude:** >50 mV for each division of display into 50 ohms with usable amplitudes up to 500 mV p-p.

**Source Impedance:** approx 50 ohms.

**GENERAL**

**OPERATING ENVIRONMENT**

**Temperature:** 0 to +55°C.

**Humidity:** to 95% relative humidity at +40°C.

**Altitude:** to 4600 m (15 000 ft).

**Vibration:** vibrated in three planes for 15 min. each with 0.254 mm (0.010 in.) excursion, 10 to 55 Hz.

**WEIGHT:** net, 2.3 kg (5 lb); shipping 3.6 kg (8 lb).

## SECTION II

### INSTALLATION

#### 2-1. INTRODUCTION.

2-2. This section contains information and instructions necessary for installing and interfacing the 1805A. Included are initial inspection procedures, installation instructions, and procedures for repacking the instrument for shipment.

#### 2-3. INITIAL INSPECTION.

2-4. This instrument was carefully inspected both mechanically and electrically before shipment. It should be free of marks or scratches and in perfect electrical order upon receipt. To confirm this, the instrument should be inspected for physical damage incurred in transit. If the instrument was damaged, file a claim with the carrier. Check for supplied accessories (listed in Section I) and test the electrical performance of the instrument using the performance test procedures outlined in Section V. If there is a deficiency, refer to the warranty in the front of this manual.

#### 2-5. PREPARATION FOR USE.



Read the safety summary at the front of the manual before installing or operating the instrument.

2-6. The 1805A and the horizontal plug-in must be locked together before installing into a 180-series oscilloscope mainframe. This procedure is explained below. Power for the 1805A is supplied by the oscilloscope through the horizontal plug-in.

#### NOTE

To adapt Model 1805A to time bases Model 1840A (serial prefix 1123A and lower) and to Model 1841A (serial prefix 1150A and lower), order modification kit HP Part Number 01840-69503 for Model 1840A and modification kit HP Part Number 01841-69506 for Model 1841A.

2-7. Install plug-ins as follows:

- a. Move locking bar to rear (figure 2-1).
- b. Fit plug into jack, making certain bulkhead connectors and guide lugs are aligned, and press plug-ins firmly together.
- c. After ensuring that front and rear panels are aligned, push locking bar forward.
- d. Lift up on latch release and rotate latch downward. Insert plug-ins into oscilloscope.
- e. Rotate latch upward and push forward to lock.

#### 2-8. REPACKING FOR SHIPMENT.

2-9. If the instrument is to be shipped to a Hewlett-Packard Sales/Service Office for service or repair, attach a tag showing owner (with address), complete instrument serial number, and a description of the service required.

2-10. Use the original shipping carton and packing material. If the original packing material is not available, the Hewlett-Packard Sales/Service Office will provide information and recommendations on materials to be used.

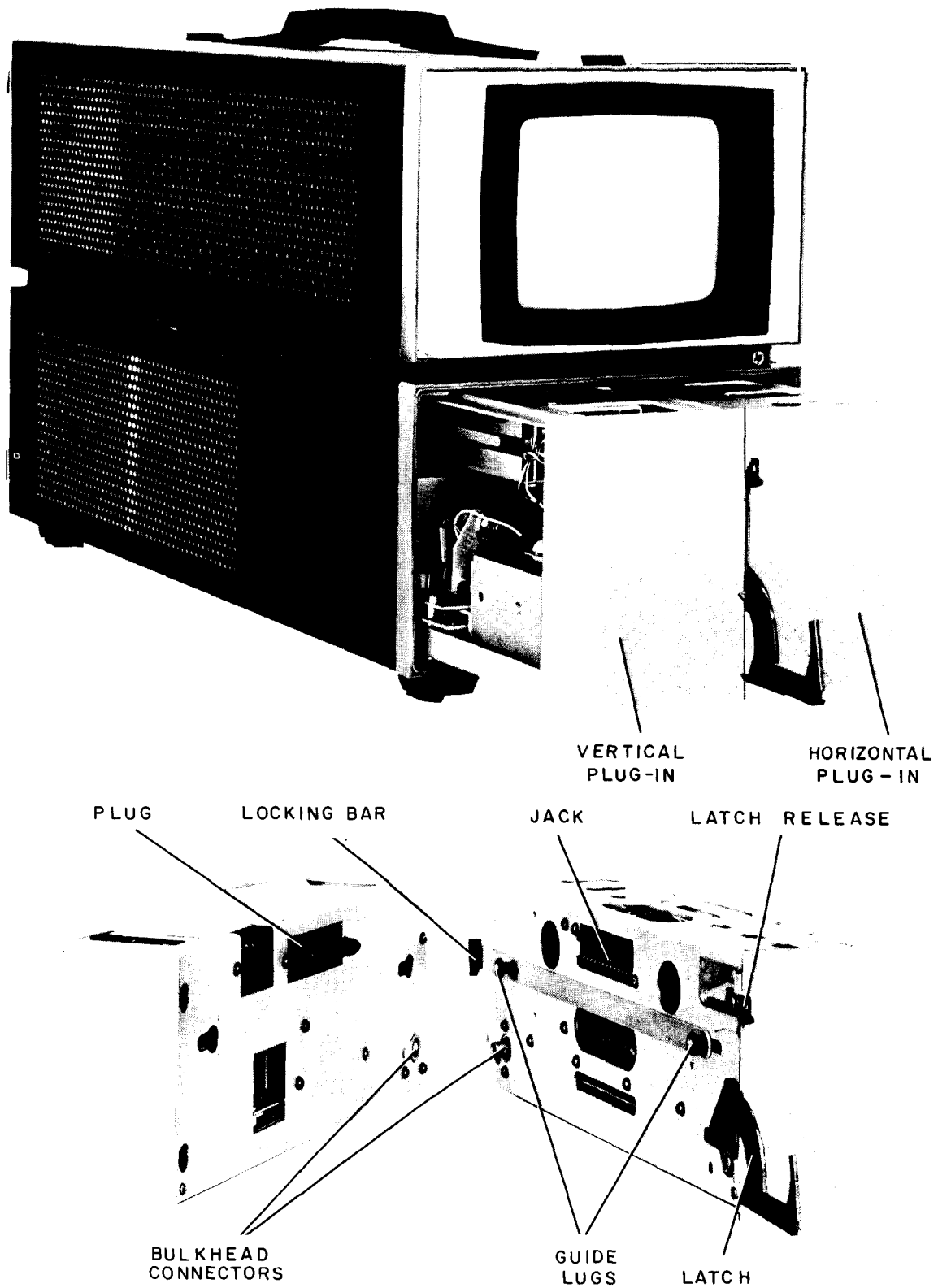

7000-A-23A

Figure 2-1. Plug-in Mating

## SECTION III OPERATION

### 3-1. INTRODUCTION.

3-2. This section provides general operating instructions and applications information for Model 1805A. Included are power and warmup information, functional identification of all controls and connectors and applications information.

### 3-3. INSTRUMENT CAPABILITIES.

3-4. The instrument contains dual vertical amplifiers for dual-channel operation. Each channel offers a choice of ac, high Z dc, or 50-ohm input coupling. With the dual trace feature, displays can be obtained on either channel A or channel B or on both channels. Simultaneous display of two signals is possible in either chop or alternate type of display. A+B and A—B mode of operation are also available.

3-5. Ten calibrated switch settings on each vertical amplifier provide a deflection factor range from 5 mV/div to 5 V/div in 1, 2, 5 sequence. The vertical verniers permit continuous adjustment between calibrated steps and extends the least sensitive deflection factor (5 V/div) to at least 12.5 V/Div.

### 3-6. GENERAL OPERATING INSTRUCTIONS.

**3-7. CONTROLS AND CONNECTORS.** Figure 3-1 provides functional descriptions of the operating controls, indicators, and connectors. Where the controls for channel A and channel B are identical, only one description is given for that control.

**3-8. INITIAL TURN-ON PROCEDURE.** To place the 1805A into operation, perform the following steps:

- a. Install 1805A and time base plug-in unit into oscilloscope mainframe (refer to Section II).
- b. Set mainframe INTENSITY control fully counterclockwise.
- c. Set mainframe DISPLAY control to internal position.
- d. Set time base plug-in AUTO/NORM control for AUTO operation.
- e. Set time base plug-in TIME/DIV switch to 0.2  $\mu$ s position.
- f. Set 1805A controls as follows (both channel A and channel B where applicable):

POSITION .....	midrange
DC OFFSET .....	OFF
Coupling.....	GND
VOLTS/DIV.....	2
VERNIER .....	CAL
DISPLAY.....	A

- g. Apply power to oscilloscope mainframe.
- h. After warmup, adjust mainframe INTENSITY and FOCUS controls for sharp, but barely visible trace.
- i. Adjust time base plug-in controls for stable display (if signal is applied).

**3-9. AMPLIFIER CALIBRATION.** Amplifier gain of the 1805A should be adjusted when the plug-in is changed from one mainframe to another. To adjust the amplifier gain proceed as follows:

- a. Accomplish paragraph 3-8.
- b. Set 1805A channel A and channel B coupling to AC.
- c. Set 1805A channel A and channel B VOLTS/DIV controls to .05 V/div.
- d. Connect mainframe 250-mV calibrator signal to channel A INPUT connector.
- e. Adjust 1805A CAL screwdriver adjustment for 5-division display.
- f. Disconnect mainframe 250-mV calibrator signal from channel A INPUT connector.

### 3-10. APPLICATION PROCEDURES.

**3-11. PEAK-TO-PEAK VOLTAGE MEASUREMENTS.** To measure the peak-to-peak voltage of an input signal, proceed as follows:

- a. Accomplish paragraphs 3-8 and 3-9.
- b. Connect input signal to 1805A channel A INPUT connector.
- c. Set channel A VOLTS/DIV control for signal amplitude display of at least three divisions.
- d. Set time base TIME/DIV control so that display contains two or three cycles of input signal.

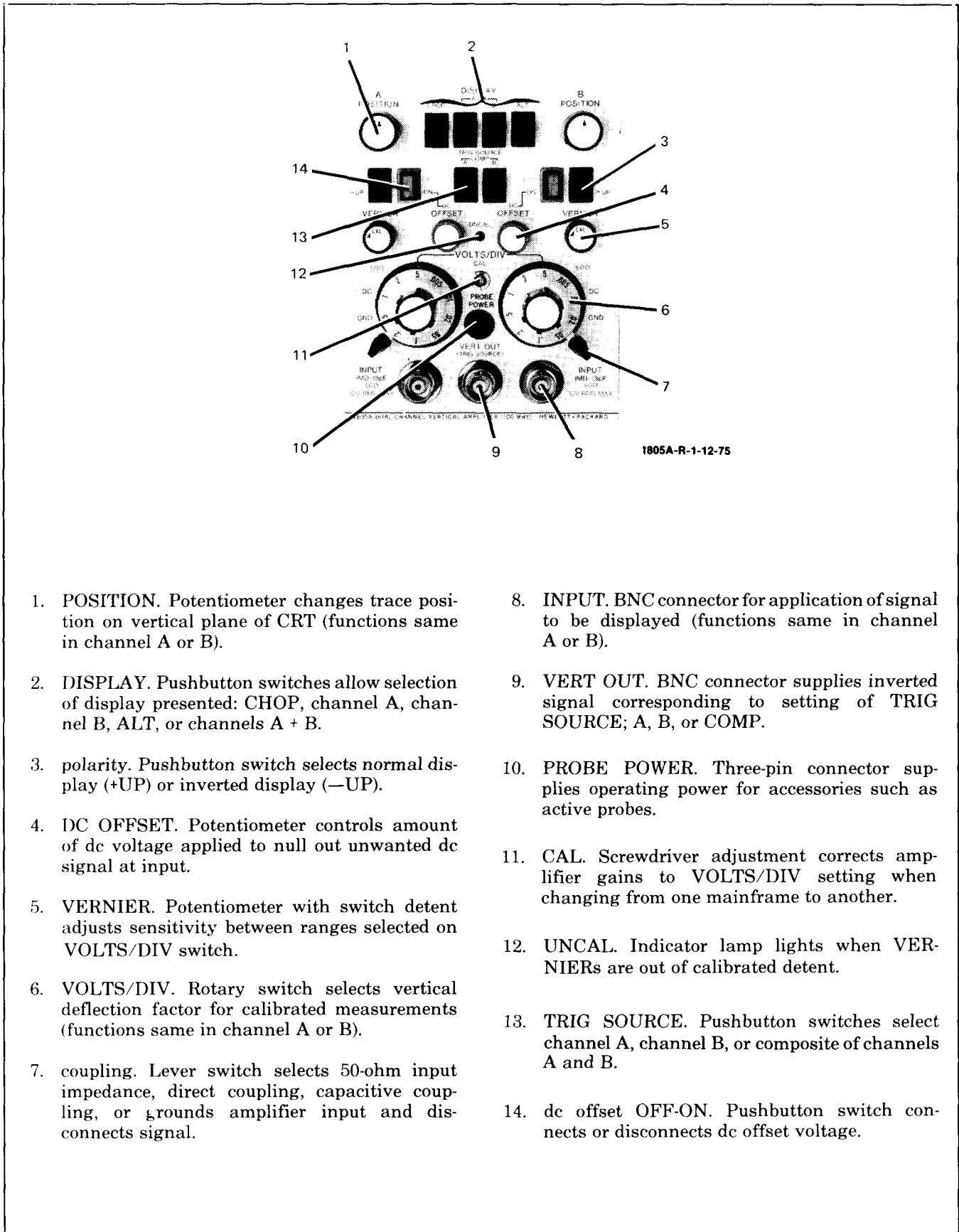

- |  |   |
|--|---|
| <ol style="list-style-type: none"> <li>1. POSITION. Potentiometer changes trace position on vertical plane of CRT (functions same in channel A or B).</li> <li>2. DISPLAY. Pushbutton switches allow selection of display presented: CHOP, channel A, channel B, ALT, or channels A + B.</li> <li>3. polarity. Pushbutton switch selects normal display (+UP) or inverted display (-UP).</li> <li>4. DC OFFSET. Potentiometer controls amount of dc voltage applied to null out unwanted dc signal at input.</li> <li>5. VERNIER. Potentiometer with switch detent adjusts sensitivity between ranges selected on VOLTS/DIV switch.</li> <li>6. VOLTS/DIV. Rotary switch selects vertical deflection factor for calibrated measurements (functions same in channel A or B).</li> <li>7. coupling. Lever switch selects 50-ohm input impedance, direct coupling, capacitive coupling, or grounds amplifier input and disconnects signal.</li> </ol> | <ol style="list-style-type: none"> <li>8. INPUT. BNC connector for application of signal to be displayed (functions same in channel A or B).</li> <li>9. VERT OUT. BNC connector supplies inverted signal corresponding to setting of TRIG SOURCE; A, B, or COMP.</li> <li>10. PROBE POWER. Three-pin connector supplies operating power for accessories such as active probes.</li> <li>11. CAL. Screwdriver adjustment corrects amplifier gains to VOLTS/DIV setting when changing from one mainframe to another.</li> <li>12. UNCAL. Indicator lamp lights when VERNIERS are out of calibrated detent.</li> <li>13. TRIG SOURCE. Pushbutton switches select channel A, channel B, or composite of channels A and B.</li> <li>14. dc offset OFF-ON. Pushbutton switch connects or disconnects dc offset voltage.</li> </ol> |
|--|---|

Figure 3-1. Controls and Connectors

e. Adjust time base controls for stable display.

f. Using 1805A channel A POSITION control, position negative peaks of input signal on horizontal line near bottom of graticule.

g. Using mainframe horizontal POSITION control, position one positive peak of input signal on center vertical graticule line.

h. Count number of vertical divisions from most negative to most positive portion of waveform (estimate to nearest tenth of division).

i. Multiply number of divisions noted in step h by channel A VOLTS/ DIV control setting for peak-to-peak voltage of input signal.

#### NOTE

If input signal is applied through divider probe, multiply results obtained in step i by attenuation factor of probe.

**3-12. DC VOLTAGE MEASUREMENTS.** To determine the dc component of an input signal or a dc level point on an input signal, proceed as follows:

a. Accomplish paragraph 3-8.

b. Connect input signal to 1805A channel A INPUT connector.

c. With channel A input coupling in GND position, position trace on convenient horizontal graticule line using channel A POSITION control.

d. Set channel A VOLTS/DIV control so that point of input signal to be measured is as far as possible from zero-volt reference line selected in step c.

#### NOTE

Reference for positive dc voltages should be below center horizontal graticule line; reference for negative dc voltages should be above center horizontal graticule line. Once horizontal graticule line is selected as reference, do not change channel A POSITION control or VOLTS/DIV control.

e. Set channel A input coupling switch to DC position.

f. Using mainframe horizontal POSITION control, move point on signal to be measured until it rests on center vertical graticule line.

g. Count number of vertical divisions between zero-volt reference graticule line and point on signal to be measured (estimate to nearest tenth of division).

h. Multiply number of divisions noted in step g by channel A VOLTS/DIV control setting for dc voltage measurement.

#### NOTE

If input signal is applied through divider probe, multiply results obtained in step h by attenuation factor of probe.

**3-13. TIME-INTERVAL MEASUREMENTS.** To measure the time interval between two events of interest, proceed as follows:

a. Accomplish paragraph 3-8.

b. Connect signal to be measured to 1805A channel A INPUT connector.

c. Set time base TIME/DIV control so that both events of interest are displayed on CRT.

d. Adjust time base controls for stable display.

e. Using mainframe horizontal POSITION control, position one measurement point on signal to convenient vertical graticule line.

f. Using 1805A channel A POSITION control, position other measurement point on center horizontal graticule line.

g. Count horizontal divisions between two measurement points (estimate to nearest tenth of division).

h. Multiply number of divisions noted in step g by time base TIME/DIV control setting for time interval between two events of interest.

**3-14. FREQUENCY CALCULATION.** To determine the approximate frequency of an input signal, proceed as follows:

a. Accomplish paragraph 3-13 using start and ending points of one cycle of input signal as events of interest.

b. Calculate input signal frequency using the following formula:

$$\frac{1}{\text{time in seconds noted in step a}}$$

**3-15. PROBE COMPENSATION.** To adjust divider probes having a compensation adjustment, proceed as follows:

a. Accomplish paragraph 3-8.

b. Connect divider probe cable to 1805A channel A INPUT connector.

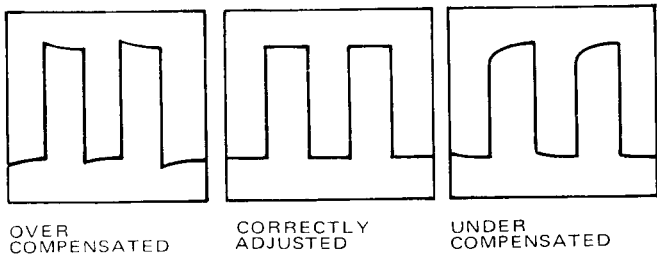

1805A-001-11-75

Figure 3-2. Divider Probe Adjustment Display

c. Connect probe tip to mainframe 250-mV CALIBRATOR terminal.

d. Set 1805A channel A VOLTS/DIV control for square-wave display having two or three divisions of vertical deflection.

e. Set time base TIME/DIV control for horizontal display of at least two full square waves.

f. Adjust divider probe compensation adjustment for correct display (see figure 3-2).

## SECTION IV

## PRINCIPLES OF OPERATION

**4-1. INTRODUCTION.**

4-2. This section contains functional descriptions keyed to an overall troubleshooting block diagram located in Section VIII. Detailed circuit descriptions are keyed to schematics that are also located in Section VIII.

**4-3. BLOCK DIAGRAM.**

4-4. Because operation of both channels are identical, the following discussion of channel A is also applicable to channel B.

**4-5. ATTENUATOR.** The input signal is applied to the attenuator through the front-panel INPUT connector. The attenuator controls the type of input coupling (50 $\Omega$ , DC, GND, AC) and it establishes the vertical deflection factor (5 mV/div to 5 V/div) as selected by the front-panel VOLTS/DIV control.

**4-6. IMPEDANCE CONVERTER.** The attenuator output is applied to differential impedance converter A6Q1A/Q1B. Field-effect transistor (FET) A6Q1A converts the single-ended, high-impedance input signal to a low-impedance, single-ended output. FET A6Q1B provides the dc-offset and channel-balance capabilities.

**4-7. PREAMPLIFIER.** Differential amplifier A6Q2/Q3 converts the single-ended input signal to a differential signal. This stage also provides a means for adjusting the gain of channel A to equal that of channel B which is fixed.

**4-8. CHANNEL A CONTROL.** The main amplifier consists primarily of control chip A6U1. This integrated circuit (IC) accepts a differential input and provides two differential outputs: (1) the main signal which after amplification, will be displayed on the CRT, and (2) the output that is applied to sync amplifier A6Q9-A6Q12. The IC also provides all functions necessary for the front-panel controls of the vertical system.

**4-9. SYNC AMPLIFIER.** Channel A and channel B sync signals are combined at the outputs of A6U1 and A6U2. The summed output is applied to sync amplifier A6Q9-Q12. The sync amplifier stage provides a gain of at least 10.

4-10. The sync amplifier output is separated into two signals. One signal is fed into a complementary emitter follower (A6Q13/Q14) that provides a low impedance source for the time base plug-in. The other signal is

fed into emitter follower A6Q15/Q16 which is used to compensate for dc drift. The output of A6Q15/Q16 is also applied to the front-panel VERT OUT connector. Output impedance of A6Q15/Q16 is 50 ohms.

**4-11. DELAY LINE.** The output from channel control A6U1 is applied through delay line drivers A6Q7/Q8 to the delay line. This line delays the input signal for 160 nanoseconds to allow the sweep to trigger before the signal reaches the CRT deflection plates.

**4-12. MAIN AMPLIFIER.** Main amplifier A7 consists primarily of integrated circuit A7U1. The remainder of the circuit provides high-frequency and gain adjustments. Gain is adjusted by two variable resistors, R6 and A7R8. In addition, the main amplifier provides current gain for output amplifiers Q1/Q2 and Q3/Q4.

**4-13. OUTPUT AMPLIFIER.** Integrated circuit A7U1 provides two outputs. One drives output amplifier Q1/Q2 and the other drives output amplifier Q3/Q4. Each amplifier is compensated by a feedback signal that is adjustable by A8C1. Outputs from Q1/Q2 and Q3/Q4 are applied to the CRT vertical deflection plates.

**4-14. CONTROL CIRCUIT.** Control circuit A3 selects the type of display to be presented on the CRT: channel A, channel B, channels A and B, ALT, or CHOP.

4-15. Pulse shaper A3U1A receives the ALT TRIGGER signal from the oscilloscope mainframe. The ALT TRIGGER signal indicates that the gate pulse has ended. The output of A3U1A is applied to J-K flip-flop A3U2 which changes state after the completion of each sweep. The flip-flop action causes the trace on the CRT to alternate between channel A and channel B. In ALT mode of operation, chop oscillator A3U1B is disabled.

4-16. In CHOP mode, the chop oscillator is enabled and the pulse shaper is disabled, inhibiting the ALT TRIGGER signal from the oscilloscope mainframe. The chop oscillator switches the trace between channels at a 400-kHz rate. The oscillator also drives chop blanking circuit A3Q1/Q2. This circuit blanks the CRT during transition between channels.

4-17. The J-K flip-flop is connected to two current switches. A3Q3/Q4 is the on-off control for the main signal path. A3Q5 through A3Q8 is the on-off control for the sync signal path. The current switches control on-off circuits in A6U1 and A6U2.



4-18. Channel control current switch A3Q3/Q4 always follows the J-K flip-flop, but can be overridden by TRIG SOURCE pushbutton A or B.

**4-19. POWER SUPPLY.** The 1805A power supply operates on 115-Vac line from the oscilloscope mainframe. The power supply rectifies and filters the line voltage into +20 Vdc. The +20 Vdc is added to +15 Vdc from the mainframe to provide the +35 Vdc operating power.

4-20. Transformer T1 is connected to the mainframe transformer which provides proper operating voltage to the 1805A whether the oscilloscope is being operated from either 115 Vac or 230 Vac.

#### 4-21. DETAILED CIRCUITRY.

4-22. The following paragraphs provide detailed explanations of individual circuits in the 1805A. Circuits that are identical for both channels are explained for channel A.

**4-23. ATTENUATORS A10 and A11. (See schematic 1.)** The 1805A employs a two-section, cam-actuated attenuator consisting of 17 in-line cams. The first three cams form coupling switch A10S1. The other 14 cams form VOLTS/DIV switch A10S2. These cams actuate pushrods which close spring-switch contacts A10A1S1 through A10A1S17 on thick-film substrate A10A1.

4-24. The first three cams form coupling switch A10S1 and actuate spring-switch contacts A10A1S1 through A10A1S3. A table located on schematic 1 explains the switch closure sequence for each of the front-panel coupling switch positions.

4-25. The last 14 cams form VOLTS/DIV switch A10S2 and actuate spring-switch contacts A10A1S4 through A10A1S17. A table on schematic 1 explains the switch closure sequence for each front-panel VOLTS/DIV setting.

4-26. The VOLTS/DIV switch is a compensated RC type attenuator consisting of two sections. Each section contains a group of attenuation networks. The first section contains X1, X10, and X100 networks. The second section has X1, X2, X4, and X10 networks. Each switch position cascades a network from the first section with a network from the second section. Different network combinations provide attenuation ranges from 5 mV/div to 5 V/div vertical deflection.

4-27. Each attenuator network has input capacitance adjustments. The straight-through range, .005 V/div, is not adjustable. The input capacitance for each range is matched to the input capacitance of the straight-through range to achieve a uniform input capacitance over the entire range of inputs. The other attenuator adjustments provide for high-frequency compensation.

**4-28. PREAMPLIFIER. (See schematic 2.)** Dual FET A6Q1 is an impedance converter that provides a high-input impedance to the attenuator and a low-output impedance to differential amplifier A6Q2/Q3.

4-29. The impedance converter has two inputs. One input is from attenuator A10 and is applied to the gate of A6Q1A. The other input is the sum of the voltages from the front-panel OFFSET control and the internal channel A balance control. The dual input provides a  $\pm 1$ -volt offset shift.

4-30. Differential amplifier A6Q2/Q3 converts the single-ended input signal from the impedance converter to a differential output. Resistors A6R23/R24 cross couple the input signal from A6Q2 to A6Q3. Capacitor A6C23 provides high-frequency compensation. Channel B has a fixed gain and channel A gain is adjusted by A6R35 to equal channel B gain.

4-31. Channel A control A6U1 is a medium scale IC that controls all vertical functions necessary for oscilloscope operation. The differential output from A6Q2/Q3 is fed into A6U1 where it is converted into two differential outputs. One is the main signal which, after amplification, is displayed on the CRT; the second output drives the sync amplifier.

4-32. Channel A and channel B signals are combined at the outputs of A6U1 and A6U2. The signal displayed on the CRT (channel A, channel B, or channels A+B) is determined by the IC's that are turned on.

4-33. The summed outputs of A6U1/U2 is the input to delay-line drivers A6Q7/Q8. A6Q7/Q8 is a differential amplifier that is temperature compensated. Temperature variations within the 1805A cause a resistance change in thermistor A6RT1. The resulting voltage change causes the capacitance in varactors A6C66 and A6C67 to change. The change in capacitance on emitters of A6Q7/Q8 maintains constant frequency response throughout the 100-MHz range of the 1805A.

4-34. Delay-line drivers A6Q7/Q8 also incorporate the oscilloscope find beam function. When the find beam pushbutton is pressed,  $-12.6$  V is removed from the junction of A6R94/R95 (through A6R96). The resulting change in bias voltage reduces the amplifier gain sufficiently to return the vertical display to the viewing area of the CRT.

**4-35. DELAY LINE. (See schematic 4.)** The delay line provides 160 nanoseconds of delay to the input signal to allow sufficient time for the sweep circuit to trigger.

**4-36. MAIN AMPLIFIER. (See schematic 4.)** Main amplifier A7 contains an integrated circuit that provides the current gain for the entire system. The gain of A7U1 is adjusted by A7R8 and front-panel CAL

control, R6. These adjustments are used to calibrate the 1805A for different mainframes.

**4-37. OUTPUT AMPLIFIER. (See schematic 4.)** Signals from the main amplifier drive shunt-output amplifiers Q1/Q2 and Q3/Q4 which provide the voltage gain to drive the CRT. Each amplifier feeds a portion of its output back to its input through a compensation network. Amplifier Q3/Q4 has a high-frequency corner adjustment HF1. The vertical deflection signal from the output amplifier is applied to the CRT deflection plates in the oscilloscope mainframe.

**4-38. SYNC AMPLIFIER. (See schematic 3.)** The sync signals from channel A and channel B are combined

at the output of channel control A6U1. The combined signal is applied to amplifier A6Q9-Q12.

4-39. The sync amplifier consists of series feedback pair A6Q9/Q10 followed by a shunt-feedback pair A6Q11/Q12. Feedback amplifier A6Q11/Q12 is the last gain stage for the internal trigger signal.

4-40. The amplified signal is applied to two paths. One path is by way of complementary emitter followers A6Q13/Q14 to J2. At J2 there will be 400 mV/div of displayed signal (3 dB down at 100 MHz). The after path provides 50-mV/div of display signal to the front-panel vertical output connector by way of emitter follower A6Q15.

Table 5-1. Recommended Test Equipment

Instrument Type	Recommended Model	Required Characteristics	Required For
Oscilloscope Mainframe Time Base	HP 180C HP 1825A	Accommodate Model 1805A	Performance Checks, Adjustments, and Troubleshooting
Voltmeter Calibrator	HP 745A	400-Hz rep rate, 30-mV to 4 V amplitude, accuracy 0.2%	Deflection Factor Accuracy Check, Vernier Check, DC Offset Voltage. Volts/div Cal Adjust
Constant-amplitude Signal Generator		50-kHz to 100-MHz rep rate, 120-mV to 5 V, constant amplitude	Bandwidth Check, CMR Check, Vertical Output Amplitude, Vertical Output Bandwidth
Square-wave Generator	HP 211B	10-kHz rep rate, 30-mV amplitude	Attenuator Adjustment
Pulse Generator		Rise Time $\leq 1.0$ ns, amplitude $\geq 0.5$ V overshoot and ringing $< 2\%$ , pulse width $> 1$ usec, perturbation $< 1\%$	Rise Time Check, Pulse Response Adjustment
50-ohm BNC Tee Connector	HP 1250-0787	BNC connector	CMR Check, Vertical Output, Bandwidth
10:1 Divider Probe	HP 10014A	10:1 division ratio, 10 megohm shunted by approx 10 pF Input RC, 8 to 28 pF compensation range	Polarity Check
Plug-in Extender	HP 10407B	HP 180-system plug-in extender	Adjustments and Troubleshooting
VHF Oscillator	HP 3200B	100-MHz, 120-mW, 50-ohm output impedance	VSWR Check
Vector Voltmeter	HP 8405A	100-MHz, 300 $\mu$ V to 1.0 V ranges, dual channel	VSWR Check
Coaxial Dual Directional Coupler	HP 778D	100-MHz frequency range	VSWR Check
10-dB Attenuator	8491A	10-dB attenuation, Type-N connectors	Bandwidth Check VSWR Check
50-ohm Tee (2)	HP 11536A	50-ohm Tee, Type-N input, Type-N output	VSWR Check
50-ohm Termination (2)	HP 908A	Type-N connector	Vertical Output Bandwidth, VSWR
RF Voltmeter	HP 3406A	10-kHz to 1.2 GHz, 1-mV to 3 V amplitude	Vertical Output Bandwidth Check
50-ohm Tee	HP 11063A	50-ohm Tee GR type connections	Vertical Output Bandwidth Check

## SECTION V

### PERFORMANCE CHECK AND ADJUSTMENTS

#### 5-1. INTRODUCTION.

**WARNING**

Read the Safety Summary at the front of this manual before installing or operating the instrument.

5-2. This section contains procedures for checking instrument performance and for making all internal adjustments. Performance checks should be made in numerical sequence for best results. Also included are test setup illustrations and a list of recommended test equipment. Test points and adjustment locations are also illustrated.

#### 5-3. EQUIPMENT REQUIRED.

5-4. A complete list of required test equipment and accessories is given in table 5-1. Test equipment equivalent to that recommended may be substituted, provided it meets the required characteristics listed in table 5-1. For best results, use recently calibrated test equipment.

#### 5-5. PERFORMANCE CHECKS.

5-6. The performance checks given in this section are suitable for incoming inspections, preventive maintenance, and troubleshooting. The checks are designed

to verify the published instrument specifications. Perform the checks in the order given, and record the measured information on the performance check record at the end of this section.

#### 5-7. ADJUSTMENTS.

5-8. The adjustment procedures are arranged in a recommended sequence. While most adjustments may be made independently, it is recommended that adjustments be made sequentially as a number of adjustments are directly related to preceding or following adjustments.

#### 5-9. PERFORMANCE CHECK RECORD.

5-10. Each measurement point in the performance check is repeated in the performance check record. The pages may be removed for filing. The first time the performance check is made, enter the results on the performance check record and file it for future reference.

#### 5-11. FRONT-PANEL CONTROL SETTINGS.

5-12. The control settings listed below are to be used for each performance check and adjustment procedure. If a control is to be set to another position, it will be listed in the procedure. After the completion of each performance check or adjustment procedure, set the controls back to the original front-panel settings.

*Table 5-1. Recommended Test Equipment (Cont'd)*

Instrument Type	Recommended Model	Required Characteristics	Required For
LC Meter	HP 4332A	13 pF, ±3%	Attenuator Adjustment
Adapter	HP Part No. 1251-2277	Turn banana plug to BNC female adapter	Performance Checks
Voltmeter	HP 34740A with 34702A	50-mV, 10 volts, ±1%	Sync Level Adjustment Vert Out Level Adjustment
50-ohm Coaxial Cable (2)	HP 11086A	50-ohm coaxial cable BNC male connectors both ends 24 inches	VSWR
50-ohm Coaxial Cable (2)	HP 10502A	50-ohm coaxial cable BNC male connectors both ends 9 inches	VSWR

Control	Position
POSITION A and B	midrange
DISPLAY	A
TRIG SOURCE	A
Polarity A and B	+UP
VERNIER A and B	CAL
Coupling A and B	DC
VOLTS/DIV A and B	.005
DC OFFSET A and B	OFF

### 5-13. PERFORMANCE CHECK PROCEDURES.

**5-14. INITIAL PERFORMANCE CHECK.** Accomplish the initial performance check as follows:

a. Install 1805A with time base plug-in into oscilloscope mainframe and turn on mainframe power. Allow 15 minutes warmup time for stabilization.

#### NOTE

Set oscilloscope and time base controls for a stable trace on CRT.

b. Set DISPLAY to ALT. Two traces should appear on CRT screen.

c. Rotate channel A POSITION over its range. Channel A trace should move full vertical graticule range.

d. Rotate channel B POSITION over its range. Channel B trace should move full vertical graticule range.

e. Set DISPLAY to A + B (both pushbuttons engaged). Either channel POSITION control should move trace vertically.

f. If instrument fails to meet check, refer to Section VIII of this manual for troubleshooting information.

g. Set 1805A front-panel controls to initial settings.

**5-15. POLARITY CHECK.** Either channel may be inverted for  $\pm A \pm B$  operation.

#### Equipment Required:

10:1 divider probe

5-16. Perform polarity check as follows:

a. Set 1805A VOLTS/DIV control (both channels) to 0.5.

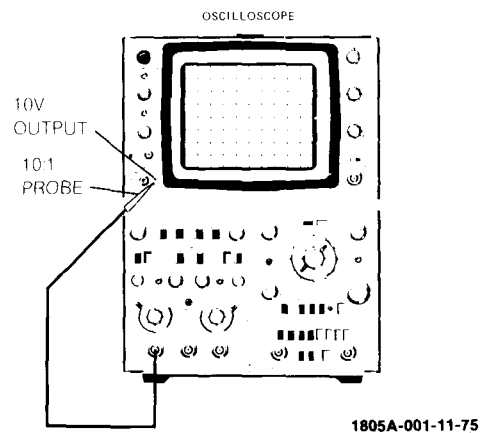

Figure 5-1. Polarity Check Test Setup

b. Center trace on CRT screen.

c. Connect equipment as shown in figure 5-1.

d. Observe square wave in lower half of CRT.

e. Switch polarity to -UP. Observe square wave in upper half of CRT.

f. Repeat steps c through e for channel B.

g. Disconnect calibrator signal.

h. Set 1805A front-panel controls to initial settings.

**5-17. DEFLECTION FACTOR.** The deflection factor is checked by applying a 400-Hz, voltage-calibrated signal to the input. The displayed signal is compared against the voltage standard.

#### Equipment Required:

Voltmeter calibrator  
24-in. coaxial cable  
Adapter

5-18. Perform deflection factor check as follows:

a. Connect equipment as shown in figure 5-2.

b. Set voltmeter calibrator for 400-Hz, 30-mV p-p output signal.

c. Set time base controls to display approximately four cycles.

d. Observe vertical deflection factors specified in table 5-2.

e. Set channel A VOLTS/DIV control to 5.

f. Set voltmeter calibrator output for 30 V.

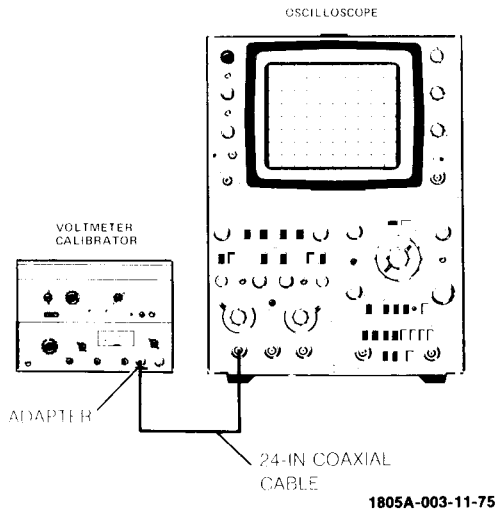

Figure 5-2. Deflection Factor Test Setup

- g. Rotate channel A vernier fully counterclockwise. Vernier UNCAL lamp should light and display amplitude should decrease to less than 2.4 divisions.
- h. Set channel A vernier to CAL detent.
- i. Connect voltmeter calibrator to channel B INPUT connector.
- j. Repeat steps b through h for channel B.
- k. Disconnect test equipment.
- l. Set 1805A front-panel controls to initial settings.

Table 5-2. Deflection Factor Accuracy

Voltmeter Calibrator Settings (Volts p-p)	VOLTS/DIV Settings	Vertical Display (div)
.03	.005	6 ±2% (±.12)
.05	.01	5 ±2% (±.1)
.1	.02	5 ±2% (±.1)
.3	.05	6 ±2% (±.12)
.5	.1	5 ±2% (±.1)
1	.2	5 ±2% (±.1)
3	.5	6 ±2% (±.12)
5	1	5 ±2% (±.1)
10	2	5 ±2% (±.1)
30	5	6 ±2% (±.12)

**5-19. DC OFFSET VOLTAGE.** The dc offset is checked by applying a dc voltage of sufficient value to drive trace off screen. The dc offset control is then adjusted to return trace to screen.

**Equipment Required:**

- Voltmeter calibrator
- 24-in. coaxial cable
- Adapter

5-20. Perform dc offset check as follows:

- a. Connect equipment as shown in figure 5-2.
- b. Set 1805A channel A and channel B DC OFFSET controls to ON.
- c. Set voltmeter calibrator for +1-Vdc output.
- d. Adjust channel A DC OFFSET control to position trace on screen.
- e. Set voltmeter calibrator for -1-Vdc output.
- f. Adjust channel A DC OFFSET control to position trace on screen.
- g. Repeat steps a through f for channel B.
- h. Disconnect test equipment.
- i. Set 1805A front-panel controls to initial settings.

**5-21. RISE TIME.** A step with a rise time of less than 400 picoseconds is applied to the vertical input. The displayed rise time is then checked to see that it is less than 3.5 nanoseconds.

**Equipment Required:**

- Fast-rise pulse generator
- 24-in. coaxial cable

5-22. Perform rise time check as follows:

- a. Connect equipment as shown in figure 5-3.

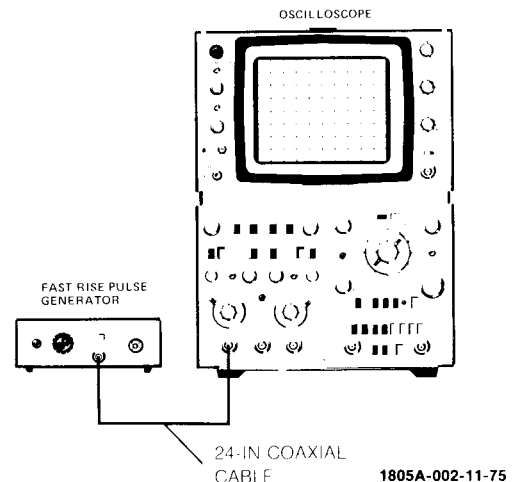

Figure 5-3. Rise Time Test Setup

- b. Set 1805A front-panel controls as follows:  
 VOLTS/DIV (both channels)..... .01  
 Coupling (both channels)..... 50Ω
- c. Set pulse generator for 100-kHz, 60-mV output.
- d. Adjust oscilloscope horizontal POSITION control as necessary to measure rise time.
- e. Observed rise time shall be less than 3.5 nanoseconds (10% to 90% points).
- f. Repeat steps a through e for channel B.
- g. Disconnect test equipment.
- h. Set 1805A front-panel controls to initial settings.

**5-23. BANDWIDTH CHECK.** To check the bandwidth, a constant-amplitude signal generator is used to apply an 8-division, 1-MHz reference signal to the input of Model 1805A. The constant-amplitude signal generator frequency is increased to 100 MHz. Displayed amplitude on CRT must be equal to or greater than 5.6 divisions.

**Equipment Required:**

- Constant-amplitude signal generator
- 10-dB attenuator
- Two 24-in. coaxial cables

5-24. Perform bandwidth check as follows:

- a. Connect equipment as shown in figure 5-4.
- b. Set 1805A channel A and channel B coupling to 50Ω.

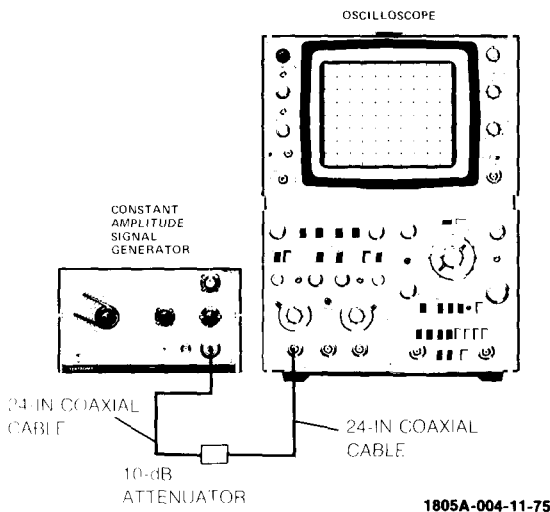

Figure 5-4. Bandwidth Test Setup

- c. Set constant-amplitude signal generator for 50 kHz output.
- d. Adjust signal generator for 8-division display.
- e. Increase signal generator frequency to 100 MHz. Deflection shall be ≥5.6 divisions (3 dB down).
- f. Reconnect signal generator and 10-dB attenuator to channel B INPUT.
- g. Set DISPLAY and TRIG SOURCE to B.
- h. Repeat steps c through e for channel B.
- i. Disconnect test equipment.
- j. Set 1805A front-panel controls to initial settings.

**5-25. COMMON MODE REJECTION.** Identical signals are applied to channels A and B with channel B set to the inverted mode. The displayed signal is the common mode signal.

**Equipment Required:**

- Constant-amplitude signal generator
- 50-ohm BNC tee
- 24-in. coaxial cable
- Two 9-in. coaxial cables

5-26. Perform common mode rejection check as follows:

- a. Connect equipment as shown in figure 5-5.

**NOTE**

Coaxial cables to channel A and B INPUTS must be of equal electrical length.

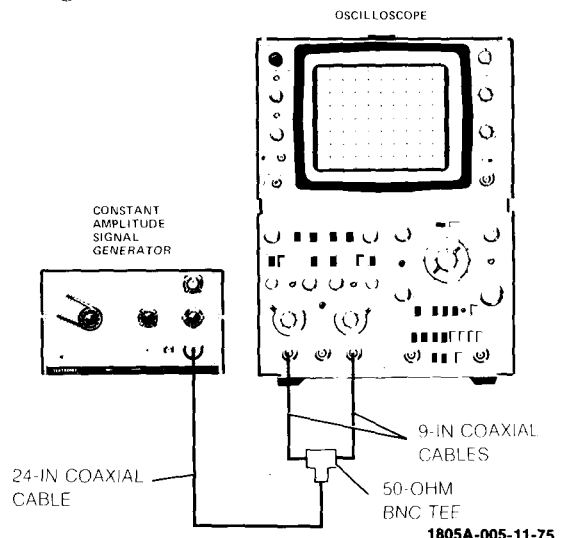

Figure 5-5. CMR Test Setup

- b. Set 1805A front-panel controls as follows:
  - Polarity (channel B) ..... —UP
  - VOLTS/DIV (channel A) ..... .01
  - Coupling (both channels)..... 50Ω
- c. Set signal generator output for 50-kHz, 8-division display.
- d. Set channel A VOLTS/DIV to .005.
- e. Set DISPLAY to A + B. Deflection shall be ≤0.16 division.

**NOTE**

Adjust either channel A or channel B vernier (whichever is most effective) to achieve deflection in steps e and h.

- f. Set DISPLAY to A.
- g. Set signal generator output to 50-MHz, 6-division display.
- h. Set DISPLAY to A + B. Deflection shall be ≤0.6 division.
- i. Disconnect test equipment.
- j. Set 1805A front-panel controls to initial settings.

**5-27. VERTICAL OUTPUT AMPLITUDE.** The vertical output signal amplitude is checked against a known input standard.

**Equipment Required:**

- Constant-amplitude signal generator
- 24-in. coaxial cable
- 9-in. coaxial cable

5-28. Perform the vertical output amplitude check as follows:

- a. Connect equipment as shown in figure 5-6.
- b. Set 1805A front-panel controls as follows:
  - VOLTS/DIV ..... .05
  - Coupling (both channels)..... 50Ω
- c. Set signal generator output for 50-kHz, 5-division display.
- d. Set DISPLAY to B. Deflection shall be ≥5 divisions.
- e. Disconnect test equipment.
- f. Set 1805A front-panel controls to initial settings.

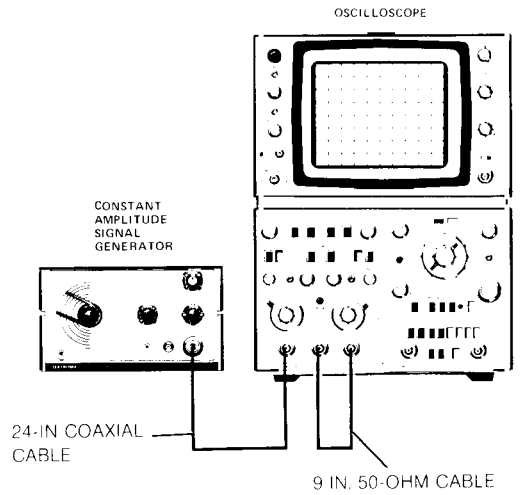

1805A-006-11-75

Figure 5-6. Vertical Output Amplitude Test Setup

**5-29. VERTICAL OUTPUT BANDWIDTH.** The bandwidth of the vertical output amplifier is checked against a known standard.

**Equipment Required:**

- Constant-amplitude signal generator
- RF voltmeter
- 50-ohm tee
- 50-ohm termination
- Two 24-in. coaxial cables

5-30. Perform vertical output bandwidth check as follows:

- a. Connect equipment as shown in figure 5-7.
- b. Set 1805A input coupling control (both channels) to 50Ω.

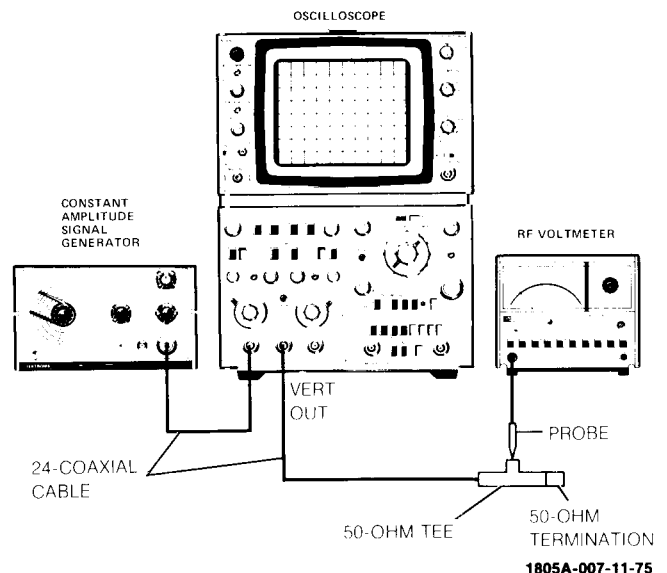

1805A-007-11-75

Figure 5-7. Vertical Output Bandwidth Test Setup



- c. Set signal generator for 50-kHz, ≈6-division display.
- d. Adjust signal generator output for 300-mV indication on RF voltmeter.
- e. Increase frequency of signal generator to 50 MHz. RF voltmeter should indicate >212 mV p-p.
- f. Repeat steps c through e for channel B.
- g. Disconnect test equipment.
- h. Set 1805A front-panel controls to initial settings.

**5-31. TRIGGERING.** Internal triggering is checked against certain vertical deflections on the CRT.

**Equipment Required:**

- Constant-amplitude signal generator
- 24-in. coaxial cable

5-32. Perform triggering check as follows:

- a. Connect signal generator to channel A INPUT connector.
- b. Set 1805A channel A VOLTS/DIV control to 0.5.
- c. Observe displays as specified in table 5-3.

Table 5-3. Triggering

Time Base Plug-in	Constant-amplitude Signal Generator	Vertical Deflection Required to Trigger
1820C, 1824A 1825A, 1840A	50 MHz	>0.5 division
1841A	100 MHz	>1 division
1820B, 1822A	50 MHz 100 MHz	>0.5 division >2 divisions
1820A, 1821A	50 MHz	>1 division

- d. Disconnect test equipment.
- e. Set 1805A front-panel controls to initial settings.

**5-33. VSWR CHECK.** The input standing-wave ratio is checked against known standards.

**Equipment Required:**

- VHF oscillator
- Vector voltmeter
- Coaxial dual directional coupler
- 10-dB attenuator
- Two 50-ohm tees
- Two 50-ohm terminations
- 24-in. coaxial cable
- 9-in. coaxial cable

5-34. Perform voltage standing-wave ratio check as follows:

- a. Connect equipment as shown in figure 5-8.
- b. Set Model 1805A input coupling (both channels) to 50Ω.
- c. Set VHF oscillator for 100-MHz output.
- d. Set vector voltmeter to measure its channel A input.
- e. Set channel A of vector voltmeter to —30-dB range.
- f. Set VHF oscillator output to obtain 0-dB reading on vector voltmeter.
- g. Set vector voltmeter to measure its channel B input.
- h. Subtract channel B reading from channel A reading. Test result given in table 5-4.
- i. Switch Model 1805A channel A VOLTS/DIV through remaining ranges and check test results as given in table 5-4.

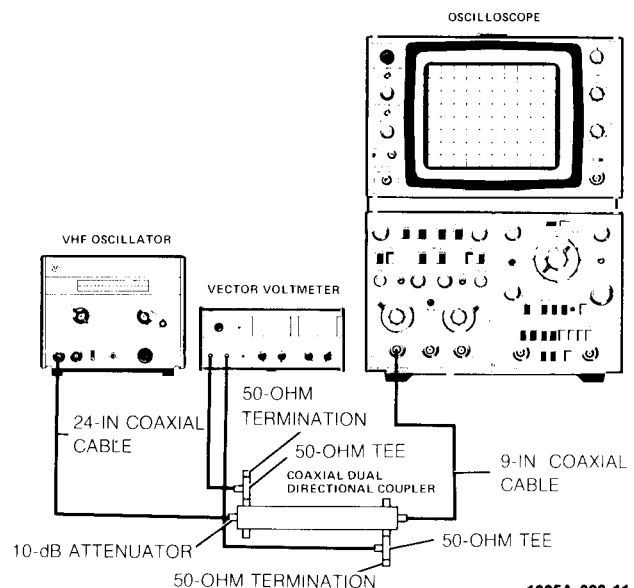

Figure 5-8. VSWR Test Setup

1805A-008-11-75

Table 5-4. VSWR

A — B (dB)	Reflection Coefficient	VSWR
>—21 dB	<0.09	<1.2:1

- j. Repeat steps c through i for channel B.
- k. Disconnect test equipment.
- l. Set Model 1805A front-panel controls to initial settings.

**5-35. ADJUSTMENTS.**



Read the Safety Summary at the front of this manual before performing adjustment procedures.

5-36. Adjustment locations are shown in figure 5-9 at the rear of this section. When making adjustments, use a non-metallic screwdriver and recently calibrated test equipment. After adjustments are completed, check the instrument performance by doing the performance checks listed at the beginning of this section.

**5-37. DC BALANCE ADJUSTMENT.** Perform dc balance adjustment as follows:

- a. Set 1805A front-panel controls in accordance with paragraph 5-12, except as follows:
  - Coupling (both channels)..... GND
  - DC OFFSET (channel A)..... ON
- b. Set oscilloscope time base for auto trigger.
- c. Press oscilloscope FIND BEAM switch.
- d. Adjust A7R13 until trace is symmetrical about CRT center line, while rotating channel A DC OFFSET control through full range.
- e. Set channel A DC OFFSET to OFF.
- f. Adjust A2R5 for zero trace shift while switching channel A polarity from +UP to —UP.
- g. Set DISPLAY to B.
- h. Set TRIG SOURCE to B.
- i. Adjust A2R9 for zero trace shift while switching channel B polarity from +UP to —UP.

- j. Set 1805A front-panel controls to initial settings.

**5-38. SYNC BALANCE ADJUSTMENT.** Perform sync balance adjustment as follows:

- a. Set 1805A front-panel controls as follows:
  - Coupling (both channels)..... GND
  - TRIG SOURCE..... COMP
- b. Connect monitor oscilloscope to VERT OUT connector.
- c. Set monitor oscilloscope input coupling to DC.
- d. Set monitor oscilloscope input sensitivity to .005 V/div.
- e. Adjust A6R56 for zero trace shift on monitor oscilloscope while switching 1805A channel A polarity from +UP to —UP.

- f. Set DISPLAY to B.

g. Adjust A6R59 for zero trace shift on monitor oscilloscope while switching 1805A channel B polarity from +UP to —UP.

- h. Disconnect monitor oscilloscope.

i. Set 1805A front-panel controls to initial settings.

**5-39. SYNC LEVEL ADJUSTMENT.** Perform sync level adjustment as follows:

- a. Set 1805A input coupling (both channels) to GND.
- b. Connect voltmeter to emitter of A6Q13.
- c. Adjust A6R114 for —0.7-volt indication on voltmeter.
- d. Disconnect voltmeter.
- e. Set 1805A front-panel controls to initial settings.

**5-40. VERT OUT LEVEL ADJUSTMENT.** Perform VERT OUT level adjustment as follows:

- a. Set 1805A input coupling (both channels) to GND.
- b. Connect voltmeter to front-panel VERT OUT connector.
- c. Adjust A6R121 for 0 volt ±50 mV.
- d. Disconnect voltmeter.

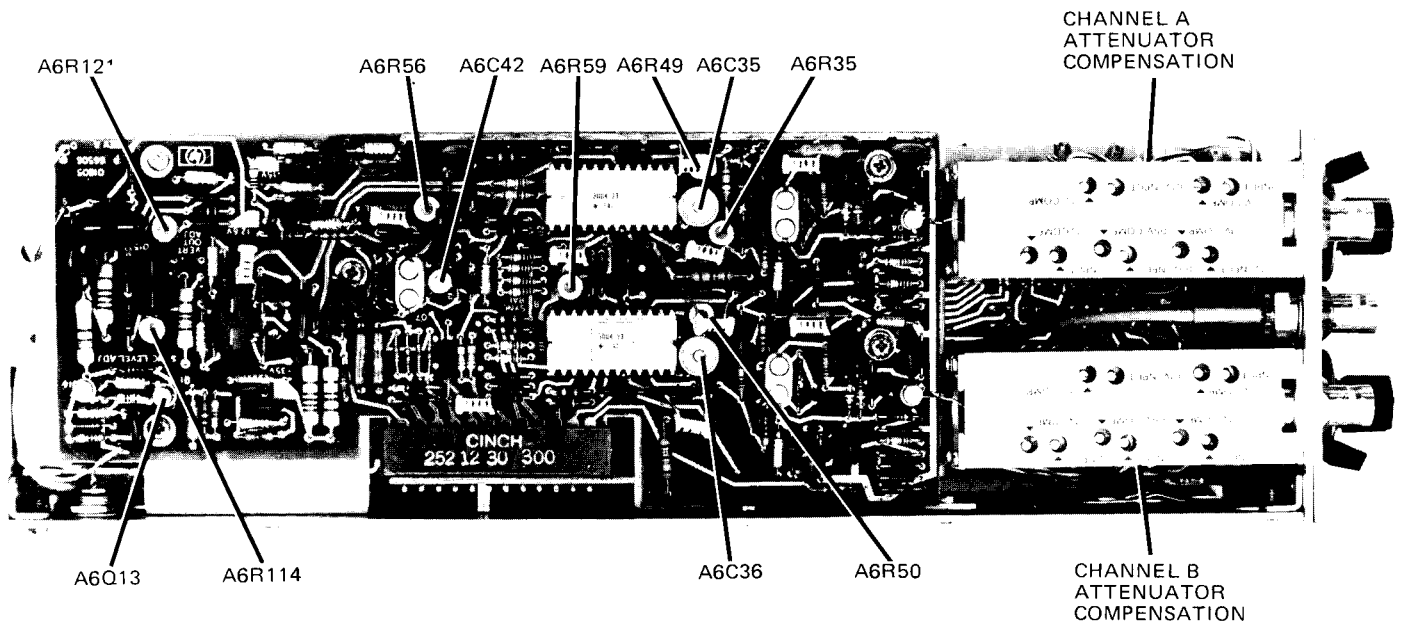
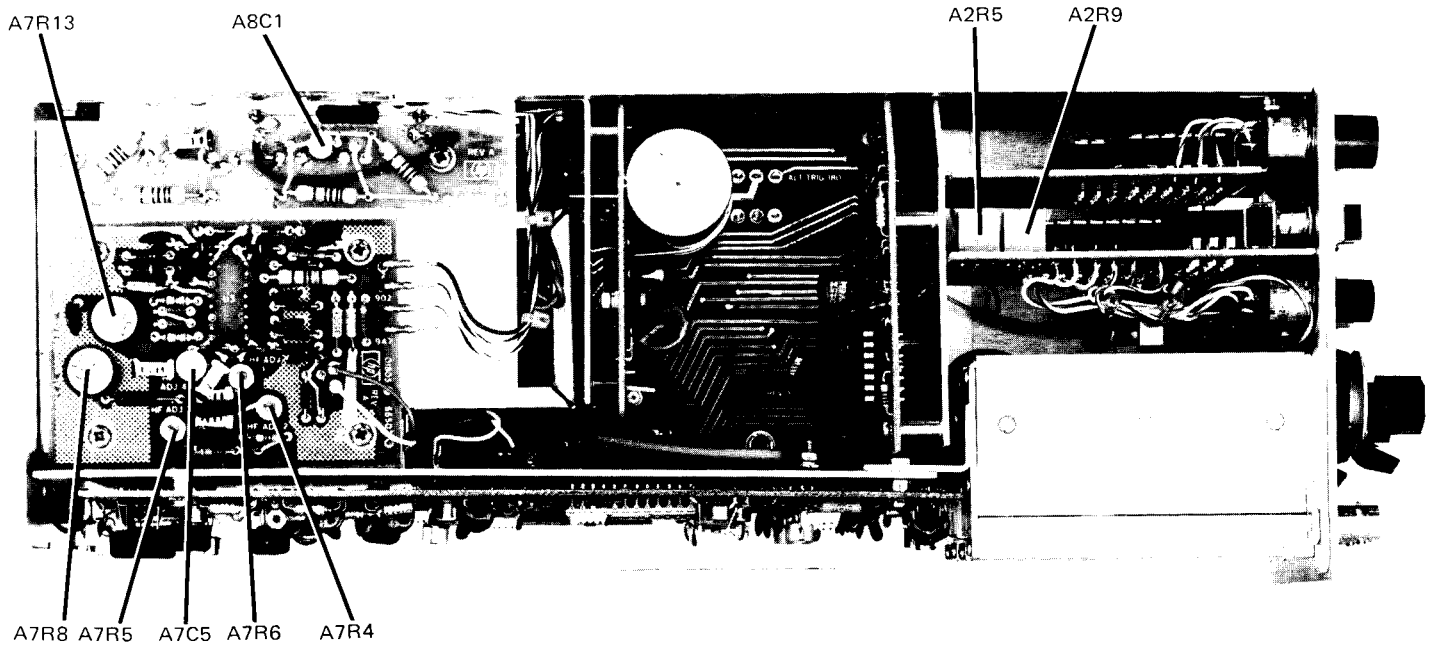

Figure 5-9. Adjustment Locations

e. Set 1805A front-panel controls to initial settings.

**5-41. VOLTS/DIV CAL ADJUSTMENT.** Calibrate the VOLTS/DIV control as follows:

- a. Set 1805A front-panel controls as follows:  
 DISPLAY..... B  
 TRIG SOURCE..... B
- b. Connect voltmeter calibrator output to channel B INPUT connector.
- c. Set voltmeter calibrator for 400-Hz, 30-mV p-p output.
- d. Adjust oscilloscope time base controls for stable display.
- e. Adjust front-panel VOLTS/DIV CAL (R6) potentiometer to midrange.
- f. Connect monitor oscilloscope to collector of Q1 (make connection at output board A8).
- g. Adjust A7R8 for 9-volt display on monitor oscilloscope.
- h. Disconnect monitor oscilloscope.
- i. Adjust front-panel VOLTS/DIV CAL potentiometer for 6-division display.
- j. Set DISPLAY to A.
- k. Set TRIG SOURCE to A.
- l. Connect voltmeter calibrator to channel A INPUT connector.
- m. Set voltmeter calibrator for 400-Hz, 30-mV p-p output.
- n. Adjust A6R35 for 6-division display.
- o. Disconnect test equipment.

**NOTE**

Gain in the 50Ω position may differ from the gain in the AC and DC positions. This difference will be proportional to the amount of resistance in the input lead (1 ohm will cause a 2% variation). If a greater degree of accuracy in the 50Ω position is required perform the following steps:

p. Set 1805A input coupling (both channels) to 50Ω.

q. Connect accurate 30-mVdc signal to channel A INPUT connector.

**NOTE**

Ensure minimum resistance in input lead.

- r. Adjust front-panel VOLTS/DIV CAL potentiometer for exactly 6-division trace displacement.
- s. Disconnect test equipment.
- t. Set 1805A front-panel controls to initial settings.

**5-42. ATTENUATOR ADJUSTMENTS.** Perform attenuator adjustments as follows:

- a. Remove 1805A from oscilloscope mainframe.
- b. Install plug-in extender (HP Model 10407B) in oscilloscope mainframe.
- c. Install 1805A and time base plug-in into plug-in extender.
- d. Set 1805A front-panel controls as follows:  
 Coupling (both channels)..... AC  
 DISPLAY..... ALT
- e. Connect square-wave generator to channel A INPUT connector.
- f. Set square-wave generator for 10-kHz, 6-division, square-wave output.
- g. Set channel A VOLTS/DIV control as indicated in table 5-5 and make appropriate adjustments to give best square-wave response.

*Table 5-5. Compensation Adjustments*

Range	Compensation Adj
.01 V/div	.01 V COMP
.02 V/div	.02 V COMP
.05 V/div	.05 V COMP

- h. Connect square-wave generator to channel B INPUT connector.
- i. Set TRIG SOURCE to B.
- j. Repeat step g for channel B.
- k. Disconnect test equipment.
- l. Connect LC meter to channel A INPUT connector.
- m. Note input capacitance of .005 VOLTS/DIV range.

n. Set channel A VOLTS/DIV control as indicated in table 5-6 and make appropriate adjustments to obtain same input capacitance noted in step m.

Table 5-6. Attenuator Input Adjustments

Range	Input Adj
.01 V/div	.01 V INPUT
.02 V/div	.02 V INPUT
.05 V/div	.05 V INPUT

- o. Repeat steps l through n for channel B.
- p. Disconnect test equipment.
- q. Connect square-wave generator to channel A INPUT connector.
- r. Set square-wave generator for 10-kHz, 6-division, square-wave output.
- s. Set channel A VOLTS/DIV control as indicated in table 5-7 and make appropriate adjustment to give best square-wave response.

Table 5-7. Compensation Adjustment

Range	Compensation Adj
.1 V/div	.1 V COMP
1 V/div	1 V COMP

- t. Repeat steps q through s for channel B.
- u. Disconnect test equipment.
- v. Connect LC meter to channel A INPUT connector.
- w. Note input capacitance on .005 VOLTS/DIV range.
- x. Set channel A VOLTS/DIV control as indicated in table 5-8 and make appropriate adjustments to obtain same input capacitance noted in step w.

Table 5-8. Attenuator Input Adjustment

Range	Input Adj
.1 V/div	.1 V INPUT
1 V/div	1 V INPUT

- y. Repeat steps v through x for channel B.
- z. Disconnect test equipment.
- aa. Set 1805A front-panel controls to initial settings.

**5-43. PULSE RESPONSE ADJUSTMENTS.** Perform pulse response adjustments as follows:

- a. Connect pulse generator output to channel A INPUT connector.
- b. Set 1805A input coupling (both channels) to 50Ω.
- c. Set oscilloscope time base for 0.1 μs/div sweep.
- d. Adjust pulse generator for 6-division amplitude pulse.
- e. Make adjustments listed in table 5-9 for best pulse response on channel A.

**NOTE**

Change sweep time as necessary to display the best pulse.

- f. Measure pulse rise time. Rise time shall be less than 3.5 ns.
- g. Set DISPLAY to B.
- h. Set TRIG SOURCE to B.

- i. Make adjustments as listed in table 5-10 for best pulse response of channel B.

**NOTE**

It may be necessary to readjust channel A.

- j. Measure rise time. Rise time shall be less than 3.5 ns.

Table 5-9. Channel A Pulse Response Adjustments

High Frequency Corner Adjustment	Designation	Time/division
A7HF3	A7R5	5 uSec
A7HF2	A7R4	.2 uSec
A7HF4	A7C5	.05 uSec
A7HF1	A7R6	.05 uSec
A8HF1	A8C1	.05 uSec
A6HF2	A6R49	.05 uSec
A6HF1	A6C35	.05 uSec
A6HF5	A6C42	.05 uSec

Table 5-10. Channel B Pulse Response Adjustments

High Frequency Corner Adjustment	Designation	Time/division
A6HF4	A6R50	.05 uSec
A6HF3	A6C36	.05 uSec

**PERFORMANCE CHECK RECORD**

Model 1805A

Instrument Serial Number \_\_\_\_\_

Date \_\_\_\_\_

Check	Specification	Measured	
<p><b>INITIAL CHECKS</b></p> <p>ALT TRIG SOURCE B A POSITION B POSITION A + B</p>	<p>two traces two traces full range full range full range either position control</p>	<p>_____ _____ _____ _____</p>	
<p><b>POLARITY</b></p> <p>+UP  -UP</p>	<p>square wave lower half of CRT square wave upper half of CRT</p>	<p>_____ _____</p>	
<p><b>DEFLECTION FACTOR ACCURACY</b></p> <p>VOLTS/DIV .005 .01 .02 .05 .1 .2 .5 1 2 5</p> <p>VERNIER VOLTS/DIV Vernier ccw</p>	<p>6±0.12 div 5±0.10 div 5±0.10 div 6±0.12 div 5±0.10 div 5±0.10 div 6±0.12 div 5±0.10 div 5±0.10 div 6±0.12 div</p> <p>&lt;2.4 div</p>	<p>A      B</p> <p>_____ _____ _____ _____ _____ _____ _____ _____ _____ _____</p>	<p>A      B</p> <p>_____ _____</p>
<p><b>DC OFFSET VOLTAGE</b></p>	<p>adjust DC OFFSET to position trace on screen</p>	<p>A      B</p> <p>_____ _____</p>	<p>A      A</p> <p>_____ _____</p>
<p><b>RISE TIME</b></p> <p>6-division display</p>	<p>&lt;3.5 ns</p>	<p>_____ _____</p>	
<p><b>BANDWIDTH</b></p> <p>100 MHz</p>	<p>&gt;5.6 div</p>	<p>A      B</p> <p>_____ _____</p>	

**PERFORMANCE CHECK RECORD**

Model 1805A

Instrument Serial Number \_\_\_\_\_

Date \_\_\_\_\_

Check	Specification	Measured	
<p><b>COMMON MODE REJECTION</b></p> <p>50 kHz 50 MHz</p>	<p>&lt;0.16 div &lt;0.6 div</p>	<p>A _____ _____</p>	<p>B _____ _____</p>
<p><b>VERTICAL OUTPUT AMPLITUDE</b></p>	<p>&gt;5 div</p>	<p>A _____ _____</p>	<p>B _____ _____</p>
<p><b>VERTICAL BANDWIDTH</b></p>	<p>&gt;212 mV p-p</p>	<p>A _____ _____</p>	<p>B _____ _____</p>
<p><b>TRIGGERING</b></p> <p>Time Base Plug-in 1820C 1824A 1825A 1840A 1841A 1820B (50 MHz) 1822A (50 MHz) 1820B (100 MHz) 1822A (100 MHz) 1820A 1821A</p>	<p>&gt;0.5 division &gt;0.5 division &gt;0.5 division &gt;0.5 division &gt;1.0 division &gt;0.5 division &gt;0.5 division &gt;2.0 divisions &gt;2.0 divisions &gt;1.0 division &gt;1.0 division</p>		
<p><b>VSWR</b></p> <p>VOLTS/DIV .01 .02 .05 .1 .2 .5 1 2 5</p>	<p>&gt;-21 dB &gt;-21 dB &gt;-21 dB &gt;-21 dB &gt;-21dB &gt;-21 dB &gt;-21 dB &gt;-21 dB &gt;-21 dB</p>	<p>A _____ _____ _____ _____ _____ _____ _____ _____ _____</p>	<p>B _____ _____ _____ _____ _____ _____ _____ _____ _____</p>

## SECTION VI REPLACEABLE PARTS

### 6-1. INTRODUCTION.

6-2. This section contains information for ordering replacement parts. The abbreviations used in the parts list are described in table 6-1. Table 6-2 lists the parts in alphanumeric order by reference designation and includes the manufacturer and manufacturer's part number. Table 6-3 contains the list of manufacturers' codes.

### 6-3. ORDERING INFORMATION.

6-4. To obtain replacement parts from Hewlett-Packard, address order or inquiry to the nearest Hewlett-Packard Sales/Service Office and supply the following information:

- a. Instrument model and serial number.
  - b. HP part number of item(s).
  - c. Quantity of part(s) desired.
  - d. Reference designation of part(s).
- 6-5. To order a part not listed in the table, provide the following information:
- a. Instrument model and serial number.
  - b. Description of the part, including function and location in the instrument.
  - c. Quantity desired.

Table 6-1. Abbreviations for Replaceable Parts List

<b>A</b>	AMPERE(S)	<b>H</b>	HENRY(IES)	<b>NPN</b>	NEGATIVE-POSITIVE-NEGATIVE	<b>RWV</b>	REVERSE WORKING VOLTAGE
<b>ASSY</b>	ASSEMBLY	<b>HG</b>	MERCURY	<b>NSR</b>	NOT SEPARATELY REPLACEABLE	<b>S-B</b>	SLOW-BLOW
<b>BD</b>	BOARD(S)	<b>HP</b>	HEWLETT-PACKARD	<b>OBD</b>	ORDER BY DESCRIPTION	<b>SCR</b>	SILICON CONTROLLED RECTIFIER
<b>BH</b>	BINDER HEAD	<b>HZ</b>	HERTZ	<b>OH</b>	OVAL HEAD	<b>SE</b>	SELENIUM
<b>BP</b>	BANDPASS	<b>IF</b>	INTERMEDIATE FREQ.	<b>OX</b>	OXIDE	<b>SEC</b>	SECOND(S)
<b>C</b>	CENTI (10 <sup>-2</sup> )	<b>IMPG</b>	IMPREGNATED	<b>P</b>	PEAK	<b>SECT</b>	SECTION(S)
<b>CAR</b>	CARBON	<b>INCD</b>	INCANDESCENT	<b>PC</b>	PRINTED (ETCHED) CIRCUIT(S)	<b>SI</b>	SILICON
<b>CCW</b>	COUNTERCLOCKWISE	<b>INCL</b>	INCLUDE(S)	<b>PF</b>	PICOFARADS	<b>SIL</b>	SILVER
<b>CER</b>	CERAMIC	<b>INS</b>	INSULATION(ED)	<b>PHL</b>	PHILLIPS	<b>SL</b>	SLIDE
<b>CMO</b>	CABINET MOUNT ONLY	<b>INT</b>	INTERNAL	<b>PIV</b>	PEAK INVERSE VOLTAGE(S)	<b>SP</b>	SINGLE POLE
<b>COAX</b>	COAXIAL	<b>K</b>	KILO (10 <sup>3</sup> )	<b>PNP</b>	POSITIVE-NEGATIVE-POSITIVE	<b>SPL</b>	SPECIAL
<b>COEF</b>	COEFFICIENT	<b>KG</b>	KILOGRAM	<b>P/O</b>	PART OF	<b>ST</b>	SINGLE THROW
<b>COMP</b>	COMPOSITION	<b>LB</b>	POUND(S)	<b>PORC</b>	PORCELAIN	<b>STD</b>	STANDARD
<b>CONN</b>	CONNECTOR(S)	<b>LH</b>	LEFT HAND	<b>POS</b>	POSITION(S)	<b>TA</b>	TANTALUM
<b>CRT</b>	CATHODE-RAY TUBE	<b>LOG</b>	LOGARITHMIC TAPER	<b>POT</b>	POTENTIOMETER(S)	<b>TD</b>	TIME DELAY
<b>CW</b>	CLOCKWISE	<b>LPF</b>	LOW-PASS FILTER(S)	<b>P-P</b>	PEAK-TO-PEAK	<b>TFL</b>	TEFLON
<b>D</b>	DECI (10 <sup>-1</sup> )	<b>LVR</b>	LEVER	<b>PRGM</b>	PROGRAM	<b>TGL</b>	TOGGLE
<b>DEPC</b>	DEPOSITED CARBON	<b>M</b>	MILLI (10 <sup>-3</sup> )	<b>PS</b>	POLYSTYRENE	<b>THYR</b>	THYRISTOR
<b>DP</b>	DOUBLE POLE	<b>MEG</b>	MEGA (10 <sup>6</sup> )	<b>PWV</b>	PEAK WORKING VOLTAGE	<b>TI</b>	TITANIUM
<b>DT</b>	DOUBLE THROW	<b>MET FILM</b>	METAL FILM	<b>RECT</b>	RECTIFIER(S)	<b>TNLDIO</b>	TUNNEL DIODE(S)
<b>ELECT</b>	ELECTROLYTIC	<b>MET OX</b>	METAL OXIDE	<b>RF</b>	RADIO FREQUENCY	<b>TOL</b>	TOLERANCE
<b>ENCAP</b>	ENCAPSULATED	<b>MFR</b>	MANUFACTURER	<b>RFI</b>	RADIO FREQUENCY INTERFERENCE	<b>TRIM</b>	TRIMMER
<b>EXT</b>	EXTERNAL	<b>MINAT</b>	MINIATURE	<b>RH</b>	ROUND HEAD OR	<b>U</b>	MICRO (10 <sup>-6</sup> )
<b>F</b>	FARAD(S)	<b>MOM</b>	MOMENTARY	<b>RMO</b>	RACK MOUNT ONLY	<b>V</b>	VOLTS
<b>FET</b>	FIELD-EFFECT TRANSISTOR(S)	<b>MTG</b>	MOUNTING	<b>RMS</b>	ROOT MEAN SQUARE	<b>VAR</b>	VARIABLE
<b>FH</b>	FLAT HEAD	<b>MY</b>	MYLAR			<b>VDCW</b>	DC WORKING VOLT(S)
<b>FIL H</b>	FILLISTER HEAD	<b>N</b>	NANO (10 <sup>-9</sup> )			<b>W</b>	WATT(S)
<b>FXD</b>	FIXED	<b>N/C</b>	NORMALLY CLOSED			<b>W/</b>	WITH
<b>G</b>	GIGA (10 <sup>9</sup> )	<b>NE</b>	NEON			<b>WIV</b>	WORKING INVERSE VOLTAGE
<b>GE</b>	GERMANIUM	<b>N/O</b>	NORMALLY OPEN			<b>W/O</b>	WITHOUT
<b>GL</b>	GLASS	<b>NOF</b>	NEGATIVE POSITIVE ZERO (ZERO TEMPERATURE COEFFICIENT)			<b>WW</b>	WIREWOUND
<b>GRD</b>	GROUNDED						



Table 6-2. Replaceable Parts

Reference Designation	HP Part Number	Qty	Description	Mfr Code	Mfr Part Number
CHASSIS PARTS					
A1	01805-66511	1	BOARD ASSY:TOP SWITCH	28480	01805-66511
A2	01805-66502	1	BOARD ASSY:BOTTOM SWITCH	28480	01805-66502
A3	01805-66503	1	BOARD ASSY:CHANNEL SYNC	28480	01805-66503
A4	01805-66504	1	BOARD ASSY:MOTHER	28480	01805-66504
A5	01805-66505	1	BOARD ASSY:+35 VOLT SUPPLY	28480	01805-66505
A6	01805-66509	1	BOARD ASSY:PREAMP/SYNC	28480	01805-66509
A7	01805-66510	1	BOARD ASSY:MAIN AMPLIFIER	28480	01805-66510
A8	01805-66512	1	BOARD ASSY:OUTPUT	28480	01805-66512
A9	01805-61609	1	CABLE ASSY:DELAY LINE	28480	01805-61609
A10	01805-63401	1	ATTENUATOR ASSY:CHANNEL A	28480	01805-63401
A11	01805-63402	1	ATTENUATOR ASSY:CHANNEL B	28480	01805-63402
DS1	2140-0352	1	LAMP:INCANDESCENT 5.0V 0.06A	71744	683
E2	5000-0543	4	HOLDER:TRANSISTOR	28480	5000-0543
E3	5020-0513	4	CONTACT:ELECTRICAL	28480	5020-0513
E4	00183-67701	1	BASE:PILOT LIGHT	28480	00183-67701
E5	5080-9670	1	TSTR:MATCHED PAIR	28480	5080-9670
H1	2190-0084	5	WASHER-LK INTL T NO. 1/4 .256-IN-ID .408-IN-OD	78189	1214-05
H2	0590-0043	1	NUT-HEX-DBL CHAM 1/4-32-THD .375 THK	28480	0590-0043
H3	2950-0072	6	NUT-HEX-DBL CHAM 1/4-32-THD .062 THK	82389	P-1975
H4	0360-0040	1	TERMINAL, SLDR LUG, 1/4-SCR, .25/.093	73734	1958
H5	2190-0016	1	WASHER-LK INTL T NO. 3/8 .377-IN-ID .507-IN-OD	78189	1920-02
H6	2950-0043	1	NUT-HEX-DBL CHAM 3/8-32-THD .094 THK	73734	2X28200
H7	2200-0103	18	SCREW-MACH 4-40 .25-IN-LG PAN HD	28480	2200-0103
H8	2950-0145	2	NUT-SPECIALTY 15/32-32-THD .15-THK	28480	2950-0145
H9	2200-0165	6	SCREW-MACH 4-40 .25-IN-LG 82 DEG FL-HD	28480	2200-0165
H10	2200-0030	19	SCREW-MACH 4-40 .25-IN-LG PAN HD SLT-REC	28480	2200-0030
H11	2200-0109	2	SCREW-MACH 4-40 .438-IN-LG PAN HD	28480	2200-0109
J1			PART OF W1		
J2	1250-0897	1	CONNECTOR:PF BULKHEAD JACK RECEPTACLE	98291	52-149-0000
J3	5060-0467	1	CONNECTOR:PROBE POWER	28480	5060-0467
MP1	0340-0039	4	INSULATOR:BUSHING	28480	0340-0039
MP2	0340-0152	4	INSULATOR:TRANSISTOR	28480	0340-0152
MP3	5040-5996	2	LEVER:COUPLING	28480	5040-5996
MP4			DELETED		
MP5	0370-0938	2	BEZEL, PUSHBUTTON KNOB:GRAY	28480	0370-0938
MP6	1490-0968	1	BUSHING:POTENTIOMETER 1/4-32 EXT THRD	00000	0BD
MP7	5040-5994	1	SPACER:VOLTS/DIV CHANNEL B	28480	5040-5994
MP8	5040-5992	1	SPACER:VOLTS/DIV CHANNEL A	28480	5040-5992
MP9	00180-67402	2	KNOB:ASSY BLK ARROW		
MP10	00183-67406	6	PUSHBUTTON ASSY	28480	00183-67406
MP11	01803-67407	2	KNOB ASSY:CAL	28480	01803-67407
MP12	01805-00201	1	PANEL:FRONT	28480	01805-00201
MP13	01805-00206	1	PANEL:SUB	28480	01805-00206
MP14	01805-00203	1	PANEL:REAR	28480	01805-00203
MP15	01805-00602	1	SHIELD:SWITCH BOARD	28480	01805-00602
MP16	01805-01204	1	BRACKET:ATTENUATOR	28480	01805-01204
MP17	01805-01203	1	BRACKET:POWER SUPPLY	28480	01805-01203
MP18	01805-04701	1	SUPPORT:PLUG-IN	28480	01805-04701
MP19	01805-60102	1	CHASSIS ASSY	28480	01805-60102
MP20	01805-67401	2	KNOB ASSY:ATTENUATOR	28480	01805-67401
MP21	01805-67402	2	KNOB ASSY:BLANK	28480	01805-67402
MP22	01830-67402	2	PUSHBUTTON	28480	01830-67402
MP23	01841-67404	2	PUSHBUTTON ASSY	28480	01841-67404
MP24	01805-04103	1	COVER:PRE AMP	28480	01805-04103
Q1	1854-0567		TRANSISTOR NPN SI T0-39 PD=1W FT=800 MHZ	28480	1854-0567
Q2	1854-0567		TRANSISTOR NPN SI T0-39 PD=1W FT=800 MHZ	28480	1854-0567
Q3	1854-0567		TRANSISTOR NPN SI T0-39 PD=1W FT=800 MHZ	28480	1854-0567
Q4	1854-0567		TRANSISTOR NPN SI T0-39 PD=1W FT=800 MHZ	28480	1854-0567
R1	0811-0625		RESISTOR WW 140 OHM 1% 7.5W	28480	0811-0625
R2	0811-3150	2	R:FXD WW 560 OHM 1% 7W	28480	0811-3150
R3	0811-3150		R:FXD WW 560 OHM 1% 7W	28480	0811-3150
R4	2100-2066	2	R:VAR COMP 2K OHM 20% LIN 1/2W	28480	2100-2066
R5	2100-2066		R:VAR COMP 2K OHM 20% LIN 1/2W	28480	2100-2066
R6	2100-2062	1	R:VAR COMP 500 OHM 10% LIN 1/2W	28480	2100-2062
R7	2100-3277	2	RESISTOR VAR PREC 5K 20%	28480	2100-3277
R8	2100-3277		RESISTOR VAR PREC 5K 20%	28480	2100-3277
R9	2100-2588	2	R:VAR COMP 5K OHM 10% 10 CLOG 1/4W	28480	2100-2588
R10	2100-2588		R:VAR COMP 5K OHM 10% 10 CLOG 1/4W	28480	2100-2588
W1	01805-61602	1	CABLE ASSY:VERTICAL OUTPUT	28480	01805-61602
W2	01805-61603	1	CABLE ASSY:FRONT PANEL	28480	01805-61603
W3	01805-61607	1	CABLE ASSY:OUTPUT	28480	01805-61607

See introduction to this section for ordering information

Table 6-2. Replaceable Parts (Cont'd)

Reference Designation	HP Part Number	Qty	Description	Mfr Code	Mfr Part Number
A1	01805-66511	1	BOARD ASSY:TOP SWITCH	28480	01805-66511
A1CR1	1901-0040	8	DIODE:SILICON 30MA 30WV	07263	FDG1088
A1MP1	3131-0252	12	SPACER:STANDOFF	28480	3131-0252
A1R1	0684-1031	4	R:FXD COMP 10K OHM 10% 1/4W	01121	CB 1031
A1R2	0698-3439	2	R:FXD MET FLM 178 OHM 1% 1/8W	28480	0698-3439
A1R3	0698-3439		R:FXD MET FLM 178 OHM 1% 1/8W	28480	0698-3439
A1S1	3101-0534	1	PUSHBUTTON SWITCH ASSY	28480	3101-0534
A1S2			PART OF A1S1		
A1S3			PART OF A1S1		
A1S4			PART OF A1S1		
A1TB1	01805-26511	1	BOARD:BLANK PC	28480	01805-26511
A2	01805-66502	1	BOARD ASSY:BOTTOM SWITCH	28480	01805-66502
A2MP1	3131-0252		SPACER:STANDOFF	28480	3131-0252
A2R1	0684-1031		R:FXD COMP 10K OHM 10% 1/4W	01121	CB 1031
A2R2	0684-1031		R:FXD COMP 10K OHM 10% 1/4W	01121	CV 1031
A2R3	0757-0464	2	R:FXD MET FLM 90.9K OHM 1% 1/8W	28480	0757-0464
A2R4	0757-0279	2	R:FXD MET FLM 3.16K OHM 1% 1/8W	28480	0757-0279
A2R5	2100-3203	2	R:VAR 5K OHM	28480	2100-3203
A2R6	0757-0430	2	R:FXD MET FLM 2.21K OHM 1% 1/8W	28480	0757-0430
A2R7	0757-0464		R:FXD MET FLM 90.9K OHM 1% 1/8W	28480	0757-0464
A2R8	0757-0279		R:FXD MET FLM 3.16K OHM 1% 1/8W	28480	0757-0279
A2R9	2100-3203		R:VAR 5K OHM	28480	2100-3203
A2R10	0757-0430		R:FXD MET FLM 2.21K OHM 1% 1/8W	28480	0757-0430
A2R11	0757-0415	4	R:FXD MET FLM 475 OHM 1% 1/8W	28480	0757-0415
A2R12	0757-0442	2	R:FXD MET FLM 10.0K OHM 1% 1/8W	28480	0757-0442
A2R13	0757-0415		R:FXD MET FLM 475 OHM 1% 1/8W	28480	0757-0415
A2R14	0757-0442		R:FXD MET FLM 10.0K OHM 1% 1/8W	28480	0757-0442
A2R15	0757-0159	2	RESISTOR 1K OHM 1% 1/2W	28480	0757-0159
A2R16	0757-0159		RESISTOR 1K OHM 1% 1/2W	28480	0757-0159
A2S1	3101-0533	1	PUSHBUTTON SWITCH ASSY	28480	3101-0533
A2S2			PART OF A2S1		
A2S3			PART OF A2S1		
A2S4			PART OF A2S1		
A2S5			PART OF A2S1		
A2S6			PART OF A2S1		
A2TB1	01805-26502	1	BOARD:BLANK PC	28480	01805-26502
A2VR1	1902-0041	1	DIODE:BREAKDOWN 5.11V 5%	04713	SZ10939-98
A2VR2	1902-0041	1	DIODE:BREAKDOWN 5.11V 5%	04713	SZ10939-98
A3	01805-66503	1	BOARD ASSY: CHANNEL/SYNC	28480	01805-66503
A3C1	0160-3451	44	C:FXD CER 0.01 UF +80-20% 100VDCW	56289	C023B101F103ZS25-CDH
A3C2	0140-0149	1	C:FXD MICA 470 PF 5%	72136	DM15F471J3S
A3C3	0180-0291	7	C:FXD ELECT 1.0UF 10% 35VDCW	56289	150D105X9035A2-DYS
A3C4	0160-2215	2	C:FXD MICA 750 PF 5%	28480	0160-2215
A3C5	0180-0291		C:FXD ELECT 1.0 UF 10% 35VDCW	56289	150D105X9035A2-DYS
A3C6	0160-2215		C:FXD MICA 750 PF 5%	28480	0160-2215
A3C7	0150-0059	1	C:FXD CER 3.3 0.25 PF 500VDCW	72982	301-000-C0J0-339C
A3C8	0160-3451		C:FXD CER 0.01 UF +80-20% 100VDCW	56289	C023B101F103ZS25-CDH
A3C9	0180-0291		C:FXD ELECT 1.0 UF 10% 35VDCW	56289	150D105X9035A2-DYS
A3C10	0160-3451		C:FXD CER 0.01 UF +80-20% 100VDCW	56289	C023B101F103ZS25-CDH
A3C11	0180-0291		C:FXD ELECT 1.0 UF 10% 35VDCW	56289	150D105X9035A2-DYS
A3C12	0140-0198	2	C:FXD MICA 200 PF 5%	72136	ROM15F201J3C
A3C13	0140-0198	1	CAPACITOR FXD 200 PF 5%	72136	RDM15F201J3C
A3CR1	1901-0040		DIODE:SILICON 30MA 30WV	07263	FDG1088
A3O1	1854-0071	11	TSTR:SI NPN (SELECTED FROM 2N3704)	28480	1854-0071
A3O2	1854-0071		TSTR:SI NPN (SELECTED FROM 2N3704)	28480	1854-0071
A3O3	1854-0071		TSTR:SI NPN (SELECTED FROM 2N3704)	28480	1854-0071
A3O4	1854-0071		TSTR:SI NPN (SELECTED FROM 2N3704)	28480	1854-0071
A3O5	1854-0071		TSTR:SI NPN (SELECTED FROM 2N3704)	28480	1854-0071
A3O6	1854-0071		TSTR:SI NPN (SELECTED FROM 2N3704)	28480	1854-0071
A3O7	1854-0071		TSTR:SI NPN (SELECTED FROM 2N3704)	28480	1854-0071
A3O8	1854-0071		TSTR:SI NPN (SELECTED FROM 2N3704)	28480	1854-0071
A3R1	0757-0283	1	R:FXD MET FLM 2.00K OHM 1% 1/8W	28480	0757-0283
A3R2	0757-0198	1	R:FXD MET FLM 100 OHM 1% 1/2W	28480	0757-0198
A3R3	0757-0444	4	R:FXD MET FLM 12.1K OHM 1% 1/8W	28480	0757-0444
A3R4	0757-0441	1	R:FXD MET FLM 8.25K OHM 1% 1/8W	28480	0757-0441
A3R5	0698-3150	1	R:FXD MET FLM 2.37K OHM 1% 1/8W	28480	0698-3150
A3R6	0757-0273	2	R:FXD MET FLM 3.01K OHM 1% 1/8W	28480	0757-0273
A3R7	0757-0407	12	R:FXD MET FLM 200 OHM 1% 1/8W	28480	0757-0407
A3R8	0757-0407		R:FXD MET FLM 200 OHM 1% 1/8W	28480	0757-0407
A3R9	0757-0437	1	R:FXD MET FLM 4750 OHM 1% 1/8W	28480	0757-0437
A3R10	0757-0420	1	R:FXD MET FLM 750 OHM 1% 1/8W	28480	0757-0420
A3R11	0757-0407		R:FXD MET FLM 200 OHM 1% 1/8W	28480	0757-0407
A3R12	0698-0084	1	R:FXD MET FLM 2.15K OHM 1% 1/8W	28480	0698-0084
A3R13	0757-0427	2	R:FXD MET FLM 1.5K OHM 1% 1/8W	28480	0757-0427
A3R14	0757-0427		R:FXD MET FLM 1.5K OHM 1% 1/8W	28480	0757-0427
A3U1	1820-0142	1	INTEGRATED CIRCUIT:4 INPUT, 2-OR/NOR	04713	MC1004P
A3U2	1820-0102	1	INTEGRATED CIRCUIT:J-K FLIP FLOP	04713	MC1013P
A3VR1	1902-3096	1	DIODE BREAKDOWN:5.23V 5% 400 MW	28480	1902-3096
A3XA1	1251-2034	2	CONNECTOR:PC EDGE (2 X 10) 20 CONTACT	71785	252-10-30-300
A3XA2	1251-2034		CONNECTOR:PC EDGE (2 X 10) 20 CONTACT	71785	252-10-30-300

See introduction to this section for ordering information

Table 6-2. Replaceable Parts (Cont'd)

Reference Designation	HP Part Number	Qty	Description	Mfr Code	Mfr Part Number
A3XU1	1200-0441	2	SOCKET:IC 14 PIN MINIATURE	28480	1200-0441
A3XU2	1200-0441		SOCKET:IC 14 PIN MINIATURE	28480	1200-0441
A4	01805-66504	1	BOARD ASSY:MOTHER	28480	01805-66504
A4C1	0160-3451		C:FXD CER 0.01 UF +80-20% 100VDCW	56289	C023B101F103ZS25-CDH
A4C2	0160-3451		C:FXD CER 0.01 UF +80-20% 100VDCW	56289	C023B101F103ZS25-CDH
A4C3	0160-3451		C:FXD CER 0.01 UF +80-20% 100VDCW	56289	C023B101F103ZS25-CDH
A4C4	0160-3451		C:FXD CER 0.01 UF +80-20% 100VDCW	56289	C023B101F103ZS25-CDH
A4C5	0160-3451		C:FXD CER 0.01 UF +80-20% 100VDCW	56289	C023B101F103ZS25-CDH
A4C6	0160-3451		C:FXD CER 0.01 UF +80-20% 100VDCW	56289	C023B101F103ZS25-CDH
A4C7	0160-3451		C:FXD CER 0.01 UF +80-20% 100VDCW	56289	C023B101F103ZS25-CDH
A4C8	0160-3451		C:FXD CER 0.01 UF +80-20% 100VDCW	56289	C023B101F103ZS25-CDH
A4C9	0160-3451		C:FXD CER 0.01 UF +80-20% 100VDCW	56289	C023B101F103ZS25-CDH
A4C10	0160-3451		C:FXD CER 0.01 UF +80-20% 100VDCW	56289	C023B101F103ZS25-CDH
A4C11	0160-3451		C:FXD CER 0.01 UF +80-20% 100VDCW	56289	C023B101F103ZS25-CDH
A4C12	0160-3451		C:FXD CER 0.01 UF +80-20% 100VDCW	56289	C023B101F103ZS25-CDH
A4C13	0160-3451		C:FXD CER 0.01 UF +80-20% 100VDCW	56289	C023B101F103ZS25-CDH
A4C14	0160-3451		C:FXD CER 0.01 UF +80-20% 100VDCW	56289	C023B101F103ZS25-CDH
A4C15	0160-3451		C:FXD CER 0.01 UF +80-20% 100VDCW	56289	C023B101F103ZS25-CDH
A4C16	0180-0094		C:FXD ELECT 100UF +75-10% 25VDCW	56289	30D107G025DD2-DSM
A4C17	0180-0094		C:FXD ELECT 100UF +75-10% 25VDCW	56289	30D107G025DD2-DSM
A4P1	01801-27601	1	P:MALE 24 PIN	28480	01801-27601
A4XA3	1251-2026	1	CONNECTOR:PC 36 CONTACTS	71785	252-18-30-300
A4XA5	1251-0472	1	CONNECTOR:PC 12 CONTACTS	71785	252-06-30-300
A4XA6	1251-1626	1	CONNECTOR:PC (2 X12) 24 CONTACT	71785	252-12-30-300
A5	01805-66505	1	BOARD ASSY: +35 VOLT SUPPLY	28480	01805-66505
A5C1	0160-3665	1	C:FXD CER 0.01 UF +80-20% 500VDCW	56289	C071A501K103ZS25-CDH
A5C2	0180-2351	1	C:FXD ELECT 2000 UF +75-10% 50VDCW	56289	39D243
A5C3	0160-3451		C:FXD CER 0.01 UF +80-20% 100VDCW	56289	C023B101F103ZS25-CDH
A5C4	0160-3451		C:FXD CER 0.01 UF +80-20% 100VDCW	56289	C023B101F103ZS25-CDH
A5C5	0180-0116	1	C:FXD ELECT 6.8 UF 10% 35VDCW	56289	150D685X9035B2-DYS
A5CR1	1901-0045	4	DIODE:SILICON 0.75A 100PIV	04713	SR1358-7
A5CR2	1901-0045	1	DIODE:SILICON 0.75A 100PIV	04713	SR1358-7
A5CR3	1901-0045		DIODE:SILICON 0.75A 100PIV	04713	SR1358-7
A5CR4	1901-0045		DIODE:SILICON 0.75A 100PIV	04713	SR1358-7
A5Q1	1854-0013	1	TSTR:SI NPN	80131	2N2218A
A5Q2	1854-0300	1	TSTR:SI NPN	28480	1854-0300
A5Q3	1854-0071		TSTR:SI NPN (SELECTED FROM 2N3704)	28480	1854-0071
A5Q4	1854-0071		TSTR:SI NPN (SELECTED FROM 2N3704)	28480	1854-0071
A5Q5	1854-0071		TSTR:SI NPN (SELECTED FROM 2N3704)	28480	1854-0071
A5R1	0757-0124	1	R:FXD MET FLM 39.2K OHM 1% 1/8W	28480	0757-0124
A5R2	0757-0444		R:FXD MET FLM 12.1K OHM 1% 1/8W	28480	0757-0444
A5R3	0811-1670	1	R:FXD WW 2.2 OHM 5% 2W	28480	0811-1670
A5R4	0684-1031		R:FXD COMP 10K OHM 10% 1/4W	01121	CB 1031
A5R5	0684-6831	1	R:FXD COMP 68K OHM 10% 1/4W	01121	CB 6831
A5R6	0684-1031		RESISTOR 10K OHM 10% 1/4W	01121	CB 1031
A5TB1	01805-26505	1	BOARD:BLANK PC	28480	01805-26505
A6	01805-66509	1	BOARD ASSY: PREAMP/SYNC (A6U1 AND A6U2 NOT INCLUDED - ORDER SEPARATELY)	28480	01805-66509
A6C1	0160-3508	2	C:FXD CER 1.0 UF +80-20% 50VDCW	72982	8131-050-651-105M
A6C2	0160-3508		C:FXD CER 1.0 UF +80-20% 50VDCW	72982	8131-050-651-105M
A6C3	0160-3451		C:FXD CER 0.01 UF +80-20% 100VDCW	56289	C023B101F103ZS25-CDH
A6C4	0160-3558	8	C:FXD CER 0.1 UF 20% 50VDCW	72982	8121-050-651-104M
A6C5	0160-3558		C:FXD CER 0.1 UF 20% 50VDCW	72982	8121-050-651-104M
A6C6	0160-3558		C:FXD CER 0.1 UF 20% 50VDCW	72982	8121-050-651-104M
A6C7	0160-3558		C:FXD CER 0.1 UF 20% 50VDCW	72982	8121-050-651-104M
A6C8	0160-3451		C:FXD CER 0.01 UF +80-20% 100VDCW	56289	C023B101F103ZS25-CDH
A6C9	0160-3451		C:FXD CER 0.01 UF +80-20% 100VDCW	56289	C023B101F103ZS25-CDH
A6C10	0160-3451		C:FXD CER 0.01 UF +80-20% 100VDCW	56289	C023B101F103ZS25-CDH
A6C11	0160-3451		C:FXD CER 0.01 UF +80-20% 100VDCW	56289	C023B101F103ZS25-CDH
A6C12	0180-0230	15	C:FXD ELECT 1.0 UF 20% 50VDCW	56289	150D105X0050A2-DYS
A6C13	0180-0230		C:FXD ELECT 1.0 UF 20% 50VDCW	56289	150D105X0050A2-DYS
A6C14	0180-0197	1	C:FXD ELECT 2.2 UF 10% 20VDCW	56289	150D225X9020A2-DYS
A6C15	0160-3451		C:FXD CER 0.01 UF +80-20% 100VDCW	56289	C023B101F103ZS25-CDH
A6C16	0160-3451		C:FXD CER 0.01 UF +80-20% 100VDCW	56289	C023B101F103ZS25-CDH
A6C17	0160-3558		C:FXD CER 0.1 UF 20% 50VDCW	72982	8121-050-651-104M
A6C18	0160-3558		C:FXD CER 0.1 UF 20% 50VDCW	72982	8121-050-651-104M
A6C19	0160-3558		C:FXD CER 0.1 UF 20% 50VDCW	72982	8121-050-651-104M
A6C20	0160-3558		C:FXD CER 0.1 UF 20% 50VDCW	72982	8121-050-651-104M
*A6C21	0160-3567	4	C:FXD CER 10.0 PF 5% 100VDCW (FACTORY SELECTED VALUE)	72982	8101-100-COG-100J
*A6C22	0160-3567		C:FXD CER 10.0 PF 5% 100VDCW (FACTORY SELECTED VALUE)	72982	8101-100-COG-100J
A6C23	0160-3652	2	C:FXD CER 4.7 PF 200VDCW	72982	8101-A200-COG-479K
A6C24	0160-3652		C:FXD CER 4.7 PF 200VDCW	72982	8101-A200-COG-479K
A6C25	0160-3447	4	C:FXD CER 470 PF 10% 100VDCW	56289	C016B102F471KS25-CDH
A6C26	0180-0230		C:FXD ELECT 1.0 UF 20% 50VDCW	56289	150D105X0050A2-DYS
A6C27	0160-3447		C:FXD CER 470 PF 10% 100VDCW	56289	C016B102F471KS25-CDH

See introduction to this section for ordering information

Table 6-2. Replaceable Parts (Cont'd)

Reference Designation	HP Part Number	Qty	Description	Mfr Code	Mfr Part Number
A6C28	0160 3447	6	C:FXD CER 470 PF 10% 100VDCW	56289	C016B102F471KS25-CDH
A6C29	0180 0230		C:FXD ELECT 1.0 UF 20% 50VDCW	56289	150D105X0050A2-DYS
A6C30	0160 3447		C:FXD CER 470 PF 10% 100VDCW	56289	C016B102F471KS25-CDH
A6C31	0160 2257		C:FXD CER 10 PF 5% 500VDCW	72982	301-000-COH0-100J
A6C32	0160 2257		C:FXD CER 10 PF 5% 500VDCW	72982	301-000-COH0-100J
A6C33	0160 3565	2	C:FXD CER 6.8 PF 100VDCW	72982	8101-100-COG 689J
A6C34	0160 3565		C:FXD CER 6.8 PF 100VDCW	72982	8101-100-COG 689J
A6C35	0121 0061		C:VAR CER 5.5-18 PF NPO	72982	538-011A 5.5-18
A6C36	0121-0061		C:VAR CER 5.5-18 PF NPO	72982	538-011A 5.5-18
A6C37	0160-3451		C:FXD CER 0.01 UF +80-20% 100VDCW	56289	C023B101F103ZS25-CDH
A6C38	0180 0230	2	C:FXD ELECT 1.0 UF 20% 50VDCW	56289	150D105X0050A2-DYS
A6C39	0160 2257		C:FXD CER 10 PF 5% 500VDCW	72982	301-000-COH0-100J
A6C40	0140 0190		C:FXD MICA 39 PF 5%	72136	RDM15E390J3C
A6C41	0140 0190		C:FXD MICA 39 PF 5%	72136	RDM15E390J3C
A6C42	0121-0467		C:VAR CER 3.0-9.0 PF 100VDCW	72982	511-000-3.9A
A6C43	0180 0230	2	C:FXD ELECT 1.0 UF 20% 50VDCW	56289	150D105X0050A2-DYS
A6C44	0160 3451		C:FXD CER 0.01 UF +80-20% 100VDCW	56289	C023B101F103ZS25-CDH
A6C45	0180 0230		C:FXD ELECT 1.0 UF 20% 50VDCW	56289	150D105X0050A2-DYS
A6C46	0160 3451		C:FXD CER 0.01 CER 0.01 UF +80-20% 100VDCW	56289	C023B101F103ZS25-CDH
A6C47	0180 0230		C:FXD ELECT 1.0 UF 20% 50VDCW	56289	150D105X0050A2-DYS
A6C48	0160 0161	2	C:FXD MY 0.01 UF 10% 200VDCW	56289	192P10392-PTS
A6C49	0160 0161		C:FXD POLY .01UF ±10% 200VDCW	56289	292P10392
A6C50	0160 3451		C:FXD CER 0.01 UF +80-20% 100VDCW	56289	C023B101F03ZS25-CDH
A6C51	0180 0230		C:FXD ELECT 1.0 UF 20% 50VDCW	56289	150D105X0050A2-DYS
A6C52	0160 2257		C:FXD CER 10 PF 5% 500VDCW	72982	301-000-COH0-100J
A6C53	0180 0230	2	C:FXD ELECT 1.0 UF 20% 50VDCW	56289	150D105X0050A2-DYS
A6C54	0160 2201		C:FXD MY 51PF 300VDCW	72136	RDM15E430J3C
A6C55	0180 0230		C:FXD ELECT 1.0 UF 20% 50VDCW	56289	150D105X0050A2-DYS
A6C56	0160 3565		C:FXD CER 6.8 PF ±0.5 PF 100VDCW	28480	0160 3565
A6C57	0160-0174		C:FXD CER 0.47 UF +80% -20% 25VDCW	56289	5C11B75 CML
A6C58	0160-0174	2	C:FXD CER 0.47 UF +80% -20% 25VDCW	56289	5C11B75 CML
A6C59	0180 0230		C:FXD ELECT 1.0 UF 10% 50VDCW	56289	150D105X0050A2-DYS
A6C60	0160 3451		C:FXD CER 0.01 UF +80-20% 100VDCW	56289	C023B101F103ZS25-CDH
A6C61	0160 3451		C:FXD CER 0.01 UF +80-20% 100VDCW	56289	C023B101F103ZS25-CDH
A6C62	0180 0228		C:FXD ELECT 22UF 10% 15VDCW	56289	150D226X9015B2
A6C63	1060 3451	2	C:FXD CER 0.01 UF +80% -20% 100VDCW	56289	C023B101F103ZS25-CDH
A6C64	0160 3451		C:FXD CER 0.01 UF +80-20% 100VDCW	56289	C023B101F103ZS25-CDH
A6C65	0160 2257		C:FXD CER 10 PF 5% 500VDCW	72982	3001-000-COH0-100J
A6C66	0160 2257		C:FXD CER 10 PF 5% 500VDCW	72982	3001-000-COH0-100J
A6C67	0122-0247		C:VAR CER 10 PF 10% 60WV	04713	1N5140
A6C68	0122 0247	2	C:VAR CER 10 PF 10% 60WV	04713	1N5140
*A6C69	0160-3652		C:FXD CER 4.7 PF ±0.5 PF 200WVDC (FACTORY SELECTED VALUE)	28480	0160-3652
*A6C70	0160 3652		C:FXD CER 4.7 PF ±0.5 PF 200WVDC (FACTORY SELECTED VALUE)	28480	0160-3652
*A6C71	0160-3652		C:FXD CER 4.7 PF ±0.5 PF 200WVDC (FACTORY SELECTED VALUE)	28480	0160-3652
*A6C72	0160-3652		C:FXD CER 4.7 PF ±0.5 PF 200WVDC (FACTORY SELECTED VALUE)	28480	0160-3652
A6CR1	1901-0179	4	DIODE:SILICON 15WV	28480	1901-0179
A6CR2	1901-0179		DIODE:SILICON 15WV	28480	1901-0179
A6CR3	1901-0179		DIODE:SILICON 15WV	28480	1901-0179
A6CR4	1901-0179		DIODE:SILICON 15WV	28480	1901-0179
A6CR5	1901-0040	3	DIODE:SILICON 30MA 30WV	07263	FDG1088
A6CR6	1901-0040		DIODE:SILICON 30MA 30WV	07263	FDG1088
A6CR7	1901-0040		DIODE:SILICON 30MA 30WV	07263	FDG1088
A6CR8	1901-0040		DIODE:SILICON 30MA 30WV	07263	FDG1088
A6E1	1205-0204		HEAT DISSIPATOR:SEMICONDUCTOR	28480	1205-0204
A6E2	1205 0204	2	HEAT DISSIPATOR:SEMICONDUCTOR	28480	1205 0204
A6E3	1205 0204		HEAT DISSIPATOR:SEMICONDUCTOR	28480	1205 0204
A6L1	9100 2285		COIL/CHOKE 560 UH 10%	13019	09-A561K
A6L2	9100 2285		COIL/CHOKE 560 UH 10%	13019	09-A561K
A6L3	9100 2251		COIL:FXD RF 0.22 UH 10%	28480	9100-2251
A6L4	9100 2251	8	COIL:FXD RF 0.22 UH 10%	28480	9100 2251
A6L5	9100 2267		COIL:FXD RF 18 UH	28480	9100 2267
A6L6	9100 2251		COIL:FXD RF 0.22 UH 10%	28480	9100 2251
A6L7	9100 2251		COIL:FXD RF 0.22 UH 10%	28480	9100 2251
A6L8	9100 2251		COIL:FXD RF 0.22 UH 10%	28480	9100 2251
A6L9	9100 2251	2	COIL:FXD RF 0.22 UH 10%	28480	9100 2251
A6L10	9170 0029		BEAD:FERRITE	02114	56-590-65A2/A4
A6L11	9170 0029		BEAD:FERRITE	02114	56-590-65A2/A4
A6L12	9170 0209		BEAD:FERRITE	02114	56-590-65A2/A4
A6L13	9170 0029		CORE:FERRITE BEAD (FACTORY SELECTED)	02114	56-590-65A2/A4
A6L14	9170 0029	2	CORE:FERRITE BEAD (FACTORY SELECTED)	02114	56-590-65A2/A4
A6MP1	0380 0321		SPACER:CAPTIVE	00866	0380 0321
A6MP2	0380 0321	2	SPACER:CAPTIVE	00866	0380 0321
A6Q1	1855-0383		TSTR:DUAL FET SI N-CHANNEL	28480	1855-0383
A6Q2	5080-9675		TSTR:MATCHED QUAD	28480	5080-9675

See introduction to this section for ordering information

Table 6-2. Replaceable Parts (Cont'd)

Reference Designation	HP Part Number	Qty	Description	Mfr Code	Mfr Part Number
A6Q3			TSTR:MATCHED P/O A6Q2		
A6Q4	1855-0383		TSTR:DUAL FET SI N-CHANNEL	28480	1855-0383
A6Q5			TSTR:MATCHED P/O A6Q2		
A6Q6	5080-9674		TSTR:MATCHED P/O A6Q2	28480	5080-9674
A6Q7			TSTR:MATCHED PAIR		
A6Q8			TSTR:MATCHED P/O A6Q7		
A6Q9	1853-0203	3	TSTR:SI PNP	28480	1853-0203
A6Q10	1853-0203		TSTR:SI PNP	28480	1853-0203
A6Q11	1853-0061	2	TSTR:SI PNP	28480	1853-0061
A6Q12	1853-0061		TSTR:SI PNP	28480	1853-0061
A6Q13	1854-0019	3	TSTR:SI NPN	28480	1854-0019
A6Q14	1853-0203		TSTR:SI PNP	28480	1853-0203
A6Q15	1854-0019		TSTR:SI NPN	28480	1854-0019
A6Q16	1854-0019		TSTR:SI NPN	28480	1854-0019
A6R1	0757-0280	8	R:FXD MET FLM 1K OHM 1% 1/8W	28480	0757-0280
A6R2	0757-0280		R:FXD MET FLM 1K OHM 1% 1/8W	28480	0757-0280
A6R3	0757-0417	4	R:FXD MET FLM 562 OHM 1% 1/8W	28480	0757-0417
A6R4	0757-0417		R:FXD MET FLM 562 OHM 1% 1/8W	28480	0757-0417
A6R5	0757-0436	4	R:FXD MET FLM 4.32K OHM 1% 1/8W	28480	0757-0436
A6R6	0757-0436		R:FXD MET FLM 4.32K OHM 1% 1/8W	28480	0757-0436
A6R7	0757-0436		R:FXD MET FLM 4.32K OHM 1% 1/8W	28480	0757-0436
A6R8	0757-0436		R:FXD MET FLM 4.32K OHM 1% 1/8W	28480	0757-0436
A6R9	0698-3429	2	R:FXD MET FLM 19.6 OHM 1% 1/8W	28480	0698-3429
A6R10	0698-3429		R:FXD MET FLM 19.6 OHM 1% 1/8W	28480	0698-3429
A6R11	0757-0407		R:FXD MET FLM 200 OHM 1% 1/8W	28480	0757-0407
A6R12	0757-0394		R:FXD MET FLM 51.1 OHM 1% 1/8W	28480	0757-0394
A6R13	0757-0407		R:FXD MET FLM 200 OHM 1% 1/8W	28480	0757-0407
A6R14	0757-0394		R:FXD MET FLM 51.1 OHM 1% 1/8W	28480	0757-0394
A6R15	0757-0280		R:FXD MET FLM 1K OHM 1% 1/8W	28480	0757-0280
A6R16	0757-0280		R:FXD MET FLM 1K OHM 1% 1/8W	28480	0757-0280
A6R17	0757-0180	2	R:FXD MET FLM 31.6 OHM 1% 1/8W	28480	0757-0180
A6R18	0757-0180		R:FXD MET FLM 31.6 OHM 1% 1/8W	28480	0757-0180
A6R19	0757-0274	5	R:FXD MET FLM 1.21K OHM 1% 1/8W	28480	0757-0274
A6R20	0757-0274		R:FXD MET FLM 1.21K OHM 1% 1/8W	28480	0757-0274
A6R21	0757-0274		R:FXD MET FLM 1.21K OHM 1% 1/8W	28480	0757-0274
A6R22	0757-0274		R:FXD MET FLM 1.21K OHM 1% 1/8W	28480	0757-0274
A6R23	0698-7196	8	R:FXD FLM 21.5 OHM 2% 1/8W	28480	0698-7196
A6R24	0698-7196		R:FXD FLM 21.5 OHM 2% 1/8W	28480	0698-7196
A6R25	0698-7196		R:FXD FLM 21.5 OHM 2% 1/8W	28480	0698-7196
A6R26	0698-7196		R:FXD FLM 21.5 OHM 2% 1/8W	28480	0698-7196
A6R27	0757-0419	4	R:FXD MET FLM 681 OHM 1% 1/8W	28480	0757-0419
A6R28	0757-0419		R:FXD MET FLM 681 OHM 1% 1/8W	28480	0757-0419
A6R29	0757-0419		R:FXD MET FLM 681 OHM 1% 1/8W	28480	0757-0419
A6R30	0757-0419		R:FXD MET FLM 681 OHM 1% 1/8W	28480	0757-0419
A6R31	0757-0409	2	R:FXD MET FLM 274 OHM 1% 1/8W	28480	0757-0409
A6R32	0757-0409		R:FXD MET FLM 274 OHM 1% 1/8W	28480	0757-0409
A6R33	0757-0407		R:FXD MET FLM 200 OHM 1% 1/8W	28480	0757-0407
A6R34	0757-0407		R:FXD MET FLM 200 OHM 1% 1/8W	28480	0757-0407
A6R35	2100-2216	1	R:VAR MET FLM 5K OHM 10% LIN 1/8W	28480	2100-2216
A6R36	0757-0418	1	R:FXD MET FLM 619 OHM 1% 1/8W	28480	0757-0418
A6R37	0757-0733	2	R:FXD MET FLM 1100 OHM 1% 1/4W	28480	0757-0733
A6R38	0698-7931		RESISTOR 1.5K 10% .125W CC	01121	BB1521
A6R39	0757-0733		R:FXD MET FLM 1100 OHM 1% 1/4W	28480	0757-0733
A6R40	0698-7931		RESISTOR 1.5K 10% .125W CC	01121	BB1521
A6R41	0698-3378	4	R:FXD CARBON 51 OHM 5% 1/8W	28480	0698-3378
A6R42	0698-7203		R:FXD FLM 42.2 OHM 2% 1/8W	28480	0698-7203
A6R43	0698-7203		R:FXD FLM 42.2 OHM 2% 1/8W	28480	0698-7203
A6R44	0698-3378		R:FXD CARBON 51 OHM 5% 1/8W	28480	0698-3378
A6R45	0698-3378		R:FXD CARBON 51 OHM 5% 1/8W	28480	0698-3378
A6R46	0698-7203		R:FXD FLM 42.2 OHM 2% 1/8W	28480	0698-7203
A6R47	0698-7203		R:FXD FLM 42.2 OHM 2% 1/8W	28480	0698-7203
A6R48	0698-3378		R:FXD CARBON 51 OHM 5% 1/8W	28480	0698-3378
A6R49	2100-1984	4	R:VAR FLM 100 OHM 10% LIN 1/2W	28480	2100-1984
A6R50	2100-1984		R:VAR FLM 100 OHM 10% LIN 1/2W	28480	2100-1984
A6R51	0757-0281	4	R:FXD MET FLM 2.74K OHM 1% 1/8W	28480	0757-0281
A6R52	0757-0281		R:FXD MET FLM 2.74K OHM 1% 1/8W	28480	0757-0281
A6R53	0757-0281		R:FXD MET FLM 2.74K OHM 1% 1/8W	28480	0757-0281
A6R54	0757-0281		R:FXD MET FLM 2.74K OHM 1% 1/8W	28480	0757-0281
A6R55	0698-7025	2	R:FXD COMP 270 OHM 10% 1/8W	01121	BB 2711
A6R56	2100-1986		R:VAR CERMET 1000 OHM 10% LIN 1/2W	28480	2100-1986
A6R57	0757-0280		R:FXD MET FLM 1K OHM 1% 1/8W	28480	0757-0280
A6R58	0698-7025		R:FXD COMP 270 OHM 10% 1/8W	01121	BB 2711
A6R59	2100-1986		R:VAR CERMET 1000 OHM 10% LIN 1/2W	28480	2100-1986
A6R60	0757-0280		R:FXD MET FLM 1K OHM 1% 1/8W	28480	0757-0280
A6R61	0757-0720	2	R:FXD MET FLM 243 OHM 1% 1/4W	28480	0757-0720

See introduction to this section for ordering information

Table 6-2. Replaceable Parts (Cont'd)

Reference Designation	HP Part Number	Qty	Description	Mfr Code	Mfr Part Number
A6R62	0757-0415	2	R:FXD MET FLM 475 OHM 1% 1/8W	28480	0757-0415
A6R63	0757-0720		R:FXD MET FLM 243 OHM 1% 1/4W	28480	0757-0720
A6R64	0757-0415		R:FXD MET FLM 475 OHM 1% 1/8W	28480	0757-0415
A6R65	0757-0426		R:FXD MET FLM 1.3K OHM 1% 1/8W	28480	0757-0426
A6R66	0757-0407		R:FXD MET FLM 200 OHM 1% 1/8W	28480	0757-0407
A6R67	0757-0426	2	R:FXD MET FLM 1.3K OHM 1% 1/8W	28480	0757-0426
A6R68	0757-0407		R:FXD MET FLM 200 OHM 1% 1/8W	28480	0757-0407
A6R69	0698-7931		RESISTOR 1.5K 10% .125W CC	01121	BB 1521
A6R70	0698-7931		RESISTOR 1.5K 10% .125W CC	01121	BB 1521
A6R71	0684-1221		RESISTOR 1.2K 10% .25W FC	01121	CB 1221
A6R72	0684-1221	2	RESISTOR 1.2K 10% .25W FC	01121	CB 1221
A6R73	0684-1221		RESISTOR 1.2K 10% .25W FC	01121	CB 1221
A6R74	0757-0444		R:FXD MET FLM 12.1K OHM 1% 1/8W	28480	0757-0444
A6R75	0684-1221		RESISTOR 1.2K 10% .25W FC	01121	CB 1221
A6R76	0757-0444		R:FXD MET FLM 12.1K OHM 1% 1/8W	28480	0757-0444
A6R77	0757-0413	2	R:FXD MET FLM 392 OHM 1% 1/8W	28480	0757-0413
A6R78	0757-0424		RESISTOR 1.1K 1% .125W F	24546	C4-1/8-T0-1101-F
A6R79	0757-0346		R:FXD MET FLM 10 OHM 1% 1/8W	28480	0757-0346
A6R80	0757-0413		R:FXD MET FLM 392 OHM 1% 1/8W	28480	0757-0413
A6R81	0757-0424		RESISTOR 1.1K 1% .125W F	24546	C4-1/8-T0-1101-F
A6R82	0757-0346	2	R:FXD MET FLM 10 OHM 1% 1/8W	28480	0757-0346
A6R83	0757-0424		RESISTOR 1.1K 1% .125W F	24546	C4-1/8-T0-1101-F
A6R84	0757-0346		R:FXD MET FLM 10 OHM 1% 1/8W	28480	0757-0346
A6R85	0757-0346		R:FXD MET FLM 10 OHM 1% 1/8W	28480	0757-0346
A6R86	0757-0407		R:FXD MET FLM 200 OHM 1% 1/8W	28480	0757-0407
A6R87	0757-0424	2	RESISTOR 1.1K 1% .125W F	24546	C4-1/8-T0-1101-F
A6R88	0757-0407		R:FXD MET FLM 200 OHM 1% 1/8W	28480	0757-0407
A6R89	0698-7205		RESISTOR 51.1 OHM 2% .05W F	24546	C4-1/8-T00-51R1-G
A6R90	0698-7205		RESISTOR 51.1 OHM 2% .05W F	24546	C4-1/8-T00-51R1-G
A6R91	0698-0085		R:FXD MET FLM 2.61K OHM 1% 1/8W	28480	0698-0085
A6R92	0698-0085	1	R:FXD MET FLM 2.61K OHM 1% 1/8W	28480	0698-0085
A6R93	0757-0449		R:FXD FLM 20K OHM 1% 1/8W	28480	0757-0449
A6R94	0698-7212		R:FXD FLM 100 OHM 2% 1/8W	28480	0698-7212
A6R95	0698-7212		R:FXD FLM 100 OHM 2% 1/8W	28480	0698-7212
A6R96	0757-0739		R:FXD MET FLM 2.00K OHM 1% 1/4W	28480	0757-0739
A6R97	0757-0290	1	R:FXD MET FLM 6.19K OHM 1% 1/8W	28480	0757-0290
A6R98	0757-0407	4	R:FXD MET FLM 200 OHM 1% 1/8W	28480	0757-0407
A6R99	0757-0273		R:FXD MET FLM 3.01K OHM 1% 1/8W	28480	0757-0273
A6R100	0757-0401		R:FXD MET FLM 100 OHM 1% 1/8W	28480	0757-0401
A6R101	0757-0401		R:FXD MET FLM 100 OHM 1% 1/8W	28480	0757-0401
A6R102	0757-0280		R:FXD MET FLM 1K OHM 1% 1/8W	28480	0757-0280
A6R103	0698-0083	2	R:FXD MET FLM 1.96K OHM 1% 1/8W	28480	0698-0083
A6R104	0698-0083		R:FXD MET FLM 1.96K OHM 1% 1/8W	28480	0698-0083
A6R105	0757-0284	2	R:FXD MET FLM 150 OHM 1% 1/8W	28480	0757-0284
A6R106	0757-0284		R:FXD MET FLM 150 OHM 1% 1/8W	28480	0757-0284
A6R107	0757-0811	1	R:FXD MET FLM 392 OHM 1% 1/2W	28480	0757-0811
A6R108	0757-0159	5	R:FXD MET FLM 1000 OHM 1% 1/2W	28480	0757-0159
A6R109	0698-4037		R:FXD MET FLM 46.4 OHM 1% 1/8W	28480	0698-4037
A6R110	0698-4037	2	R:FXD MET FLM 46.4 OHM 1% 1/8W	28480	0698-4037
A6R111	0757-0421		R:FXD MET FLM 825 OHM 1% 1/8W	28480	0757-0421
A6R112	0757-0421	2	R:FXD MET FLM 825 OHM 1% 1/8W	28480	0757-0421
A6R113	0698-7028	2	R:FXD COMP 27 OHM 10% 1/8W	01121	BB 2701
A6R114	2100-1984		R:VAR FLM 100 OHM 10% LIN 1/2W	28480	2100-1984
A6R115	0698-7028	2	R:FXD COMP 27 OHM 10% 1/8W	01121	BB 2701
A6R116	0757-0806		R:FXD MET FLM 243 OHM 1% 1/8W	28480	0757-0806
A6R117	0757-0417		R:FXD MET FLM 562 OHM 1% 1/8W	28480	0757-0417
A6R118	0757-0417	1	R:FXD MET FLM 562 OHM 1% 1/8W	28480	0757-0417
A6R119	0698-3404		R:FXD MET FLM 383 OHM 1% 1/2W	28480	0698-3404
A6R120	0757-0814		R:FXD MET FLM 511 OHM 1% 1/2W	28480	0757-0814
A6R121	2100-1984		R:VAR FLM 100 OHM 10% LIN 1/2W	28480	2100-1984
A6R122	0757-0424		R:FXD MET FLM 1.10K OHM 1% 1/8W	28480	0757-0424
A6R123	0757-0424	2	R:FXD MET FLM 1.10K OHM 1% 1/8W	28480	0757-0424
A6R124	0757-0422		R:FXD MET FLM 909 OHM 1% 1/8W	28480	0757-0422
A6R125	0757-0406		R:FXD MET FLM 182 OHM 1% 1/8W	28480	0757-0406
A6R126	0757-0411		R:FXD MET FLM 332 OHM 1% 1/8W	28480	0757-0411
A6R127	0757-0426		R:FXD FLM 1.3K OHM 1% 1/8W	28480	0757-0426
A6R128	0757-0280	1	R:FXD MET FLM 1K OHM 1% 1/8W	28480	0757-0280
A6R129	0757-0420		R:FXD MET FLM 750 OHMS 1% 1/8W	28480	0757-0420
A6R130	0757-0316		RESISTOR 42.2 OHM 1% .125W F	24546	C4-1/8-T0-42R2-F
A6R131	0698-4037		R:FXD MET FLM 46.4 OHM 1% 1/8W	28480	0698-4037
A6RT1	0837-0035		1	THERMISTOR:DISC TYPE	89473
A6U1	5081-3018	2	IC:CONTROL	28480	5081-3018
A6U2	5081-3018		IC:CONTROL	28480	5081-3018
A6VR1	1902-3104		DIODE:BREAKDOWN 5.62V 5%	04713	SZ10939-110
A6VR2	1902-3104		DIODE:BREAKDOWN 5.62V 5%	04713	SZ10939-110
A6VR3	1902-0048		DIODE:BREAKDOWN 6.81V 5%	04713	SZ10939-134

See introduction to this section for ordering information

Table 6-2. Replaceable Parts (Cont'd)

Reference Designation	HP Part Number	Qty	Description	Mfr Code	Mfr Part Number
A6VR4	1902-0048		DIODE:BREAKDOWN 6.81V 5%	04713	SZ10939-134
A6VR5	1902-0783	1	DIODE:BREAKDOWN 16.2V 5%	28480	1902-0783
A6VR6	1902-3048	1	DIODE:BREAKDOWN:SILICON 3.48V 5%	28480	1902-3048
A6XA	1251-1556	100	CONNECTOR:SINGLE CONTACT	00779	2-330808-8
A7	01805-66510	1	BD ASSY:MAIN AMPL (A7U1 NOT INCLUDED - ORDER SEPARATELY)	28480	01805-66510
A7C1	0160-3451	7	C:FXD CER .01 UF 100VDCW	56289	C023B101F103ZS25-CD
A7C2	0160-3557	1	C:FXD CER 0.01 UF 20% 200VDCW	72982	8121-200-651-103M
A7C3	0160-2261	1	C:FXD CER 15 PF 5% 500VDCW	72982	301-NPO-15 PF
*A7C4	0160-2204		C:FXD 100PF 5% (FACTORY SELECTED - MAY BE OMITTED BY TEST)	72136	RDM15F-101J3C
A7C5	0121-0443	1	C:VAR CER 3.9 PF 160VDCW	28480	0121-0443
A7C6	0160-2679		C:FXD 30 PF -5% 500VDCW CER	28480	0160-2679
*A7C7	0160-3567		C:FXD 10.0 PF 100VDCW (FACTORY SELECTED VALUE)	72982	8101-100-COG-100J
A7C8	0140-0208	1	C:FXD MICA 680 PF 5%	72136	RDM15F681J3C
A7C9	0160-2260		C:FXD CER 13 PF 5% 500VDCW	72982	301-000-COGO-130J
A7C10	NOT ASSIGNED				
A7C11	0160-3451		C:FXD CER 0.01 UF +80-20% 100VDCW	56289	C023B101F103ZS25-CDH
A7C12	0180-0291		C:FXD ELECT 1.0 UF 10% 35VDCW	56289	150D105X9035A2-DYS
A7C13	0160-3451		C:FXD CER 0.01 UF +80-20% 100VDCW	56289	C023B101F103ZS25-CDH
A7C14	0160-3451		C:FXD CER 0.01 UF +80-20% 100VDCW	56289	C023B101F103ZS25-CDH
A7C15	0180-0291		C:FXD ELECT 1.0 UF 10% 35VDCW	56289	150D105X9035A2-DYS
A7C16	0180-0291		C:FXD ELECT 1.0 UF 10% 35VDCW	56289	150D105X9035A2-DYS
A7C17	0160-3451		C:FXD CER 0.01 UF +80-20% 100VDCW	56289	C023B101F103ZS25-CDH
A7C18	0160-3451		C:FXD CER 0.01 UF +80-20% 100VDCW	56289	C023B101F103ZS25-CDH
A7C19	0160-3451		C:FXD CER 0.01 UF +80-20% 100VDCW	56289	C023B101F103ZS25-CDH
A7C20	0160-3652		C:FXD CER 4.7 PF 200VDCW	28480	0160-3652
A7CR1	1901-0535	2	DIODE:HYBRID NOT CARRIER	28480	1901-0535
A7CR2	1901-0535		DIODE:HYBRID NOT CARRIER	28480	1901-0535
A7CR3	1901-0040		DIODE:SILICON 30MA 30WV	07263	FDG1088
A7CR4	1901-0040		DIODE:SILICON 30MA 30WV	07263	FDG1088
A7CR5	1901-0040		DIODE:SILICON 30WV	07263	FDG1088
A7CR6	1901-0040		DIODE:SILICON 30WV	07263	FDG1088
A7L1	9100-2251		COIL:FXD RF 0.22 UH 10%	28480	9100-2251
A7L2	9100-2251		COIL:FXD RF 0.22 UH 10%	28480	9100-2251
A7R1	0757-0401		R:FXD MET FLM 100 OHM 1% 1/8W	28480	0757-0401
A7R2	0757-0401	1	R:FXD MET FLM 100 OHM 1% 1/8W	28480	0757-0401
A7R3	0757-0446	1	R:FXD MET FLM 15.0K OHM 1% 1/8W	28480	0757-0446
A7R4	2100-2216	1	R:VAR FLM 5K OHM 10% LIN 1/2W	28480	2100-2216
A7R5	2100-2030	1	R:VAR FLM 20K OHM 10% LIN 1/2W	28480	2100-2030
A7R6	2100-2061	1	R:VAR FLM 200 OHM 10% LIN 1/2W	28480	2100-2061
A7R7	0757-0440	1	R:FXD MET FLM 7.50K OHM 1% 1/8W	28480	0757-0440
A7R8	2100-1772	2	R:VAR WW 500 OHM 5% TYPE H 1W	28480	2100-1772
A7R9	0757-0734	1	R:FXD MET FLM 1.21K OHM 1% 1/4W	28480	0757-0734
A7R10	0698-7209	2	R:FXD FLM 75 OHM 2% 1/8W	28480	0698-7209
A7R11	0698-7209		R:FXD FLM 75 OHM 2% 1/8W	28480	0698-7209
A7R12	0757-0274		R:FXD MET FLM 1.21K OHM 1% 1/8W	28480	0757-0274
A7R13	2100-1772		R:VAR WW 500 OHM 5% TYPE H 1W	28480	2100-1772
A7R14	0698-3152	2	R:FXD MET FLM 3.48K OHM 1% 1/8W	28480	0698-3152
A7R15	0698-3152		R:FXD MET FLM 3.48K OHM 1% 1/8W	28480	0698-3152
A7R16	0757-0426		R:FXD FLM 1.3K OHM 1% 1/8W	28480	0757-0426
A7R17	0757-0417		R:FXD MET FLM 562 OHM 1% 1/8W	28480	0757-0417
A7R18	0757-0806		R:FXD MET FLM 243 OHM 1% 1/8W	28480	0757-0806
A7R19	0698-3443	1	R:FXD MET FLM 287 OHM 1% 1/8W	28480	0698-3443
A7R20	0757-0276	2	R:FXD MET FLM 61.9 OHM 1% 1/8W	28480	0757-0276
A7R21	0757-0276		R:FXD MET FLM 61.9 OHM 1% 1/8W	28480	0757-0276
A7U1	5081-3005	1	IC:SEALED PACKAGE	28480	5081-3005
A7VR1	1902-3139	1	DIODE:BREAKDOWN 8.25V 5%	04713	SZ10939-158
A7VR2	1902-3097	1	DIODE:BREAKDOWN 5.23V 2%	28480	1902-3097
A7XA	1251-1556		CONNECTOR:SINGLE CONTACT	00779	2-330808-8
A8	01805-66512	1	BOARD ASSY:OUTPUT	28480	01805-66512
A8C1	0121-0466	11	C:VAR CER 1.0 TO 3.0 PF 100VDCW	72982	511-000-1-3A
A8C2	0160-3451		C:FXD CER 0.01 UF +80-20% 100VDCW	56289	C023B101F103ZS25-CDH
A8C3	0160-3451		C:FXD CER 0.01 UF +80-20% 100VDCW	56289	C023B101F103ZS25-CDH
*A8C4	0160-2236	1	C:FXD 1.0 PF 500VDCW (FACTORY SELECTED VALUE)	72982	301-000-COKO-109C
A8C5	0160-3451		C:FXD CER 0.01 UF +80-20% 100VDCW	56289	C023B101F103ZS25-CD
A8R1	0757-0159		R:FXD MET FLM 1000 OHM 1% 1/2W	28480	0757-0159
A8R2	0757-0159		R:FXD MET FLM 1000 OHM 1% 1/2W	28480	0757-0159
A8R3	0757-0159		R:FXD MET FLM 1000 OHM 1% 1/2W	28480	0757-0159
A8R4	0757-0159		R:FXD MET FLM 1000 OHM 1% 1/2W	28480	0757-0159
A9	01805-61609	1	CABLE ASSY:DELAY LINE	28480	01805-61609
A9T1	9100-3475	1	TRANSFORMER	28480	9100-3475
A10	01805-63401	1	ATTENUATOR ASSY:CHANNEL "A"	28480	01805-63401
A10J1	5020-0593	1	CONNECTOR:BNC	28480	5020-0593
A10E1	1250-0051	1	CONTACT:RF CONNECTOR BNC SERIES	02660	31-2109

See introduction to this section for ordering information

Table 6-2. Replaceable Parts (Cont'd)

Reference Designation	HP Part Number	Qty	Description	Mfr Code	Mfr Part Number
A10S1 A10S2 A10A1 A10A1C1 A10A1C2	5081-3006 0121-0467 0121-0466	2	NOT SEPARATELY REPLACEABLE NOT SEPARATELY REPLACEABLE ATTENUATOR SUBSTRATE ASSY C:VAR CER 3.0-9.0 PF 100VDCW C:VAR CER 1.0 TO 3.0 PF 100VDCW	28480 72982 72982	5081-3006 511-000-3-9A 511-000-1-3A
A10A1C3 A10A1C4 A10A1C5 A10A1C6 A10A1C7	0121-0467 0121-0466 0121-0467 0121-0466 0121-0466		C:VAR CER 3.0-9.0 PF 100VDCW C:VAR CER 1.0 TO 3.0 PF 100VDCW C:VAR CER 3.0-9.0 PF 100VDCW C:VAR CER 1.0 TO 3.0 PF 100VDCW C:VAR CER 1.0 TO 3.0 PF 100VDCW	72982 72982 72982 72982 72982	511-000-3-9A 511-000-1-3A 511-000-3-9A 511-000-1-3A 511-000-1-3A
A10A1C8 A10A1C9 A10A1C10 A11 A11J1	0121-0467 0121-0466 0121-0467 01805-63402 5020-0593	1	C:VAR CER 3.0-9.0 PF 100VDCW C:VAR CER 1.0 TO 3.0 PF 100VDCW C:VAR CER 3.0-9.0 PF 100VDCW ATTENUATOR ASSY:CHANNEL "B" CONNECTOR:BNC	72982 72982 72982 28480 28480	511-000-3-9A 511-000-1-3A 511-000-3-9A 01805-63402 5020-0593
A11E1 A11S1 A11S2 A11A1 A11A1C1	1250-0051   5081-3006 0121-0467		CONTACT:RF CONNECTOR BNC SERIES NOT SEPARATELY REPLACEABLE NOT SEPARATELY REPLACEABLE ATTENUATOR SUBSTRATE ASSY C:VAR CER 3.0-9.0 PF 100VDCW	02660   28480 72982	31-2109   5081-3006 511-000-3-9A
A11A1C2 A11A1C3 A11A1C4 A11A1C5 A11A1C6	0121-0466 0121-0467 0121-0466 0121-0467 0121-0466		C:VAR CER 1.0 TO 3.0 PF 100VDCW C:VAR CER 3.0-9.0 PF 100VDCW C:VAR CER 1.0 TO 3.0 PF 100VDCW C:VAR CER 3.0-9.0 PF 100VDCW C:VAR CER 1.0 TO 3.0 PF 100VDCW	72982 72982 72982 72982 72982	511-000-1-3A 511-000-3-9A 511-000-1-3A 511-000-3-9A 511-000-1-3A
A11A1C7 A11A1C8 A11A1C9 A11A1C10	0121-0466 0121-0467 0121-0466 0121-0467		C:VAR CER 1.0 TO 3.0 PF 100VDCW C:VAR CER 3.0-9.0 PF 100VDCW C:VAR CER 1.0 TO 3.0 PF 100VDCW C:VAR CER 3.0-9.0 PF 100VDCW	72982 72982 72982 72982	511-000-1-3A 511-000-3-9A 511-000-1-3A 511-000-3-9A

Table 6-3. List of Manufacturers' Codes

MFR. NO.	MANUFACTURE NAME	ADDRESS	ZIP CODE
00000	U. S. A. COMMON	ANY SUPPLIER OF U. S. A.	
00779	AMP, INC.	HARRISBURG, PA.	17605
01121	ALLEN BRADLEY, CO.	MILWAUKEE, WI.	53212
04713	MOTOROLA, INC.	PHOENIX, AZ.	85008
07263	FAIRCHILD CAMERA & INST., CORP.	MOUNTAIN VIEW, CA.	94040
13019	AIRCO SUPPLY CO., INC.	WICHITA, KA.	67213
56289	SPRAGUE ELECTRIC, CO.	NORTH ADAMS, MA.	01247
71744	CHICAGO MINIATURE LAMP WORKS	CHICAGO, IL.	60640
71785	CINCH MFG., CO.	CHICAGO, IL.	60007
72136	ELECTRO MOTIVE MFG., CO.	WILLIMANTIC, CT.	06226
72982	ERIE TECHNOLOGICAL PRODUCTS, INC.	ERIE, PA.	16512
* 80131	ELECTRONIC INDUSTRIES ASSOCIATION		
98291	SEAELECTRO, CORP.	MAMARONECK, N. Y.	10544

See introduction to this section for ordering information



## SECTION VII MANUAL CHANGES

### 7-1. INTRODUCTION.

7-2. This section contains information required to backdate this manual for a specific instrument.

### 7-3. MANUAL CHANGES.

7-4. This manual applies directly to the instrument having the same serial prefix shown on the manual title page. If the serial prefix of the instrument is not the same as the one on the title page, find your serial prefix in table 7-1 and make the changes to the manual that are listed for that serial prefix (refer to paragraph 7-5). When making changes listed in table 7-1, make the change with the highest number first. Example: if backdating changes 1, 2, and 3 are required for your serial prefix, do change 3 first, then change 2, and finally change 1. If the serial prefix of the instrument is not listed either in the title page or in table 7-1, refer to an enclosed MANUAL CHANGES sheet for updating information. Also, if a MANUAL CHANGES sheet is supplied, make all indicated ERRATA corrections.

*Table 7-1. Manual Changes*

Serial Prefix	Make Changes
1205A	1, 2, 3, 4, 5, 6, 7, 8
1233A	2, 3, 4, 5, 6, 7, 8
1239A	3, 4, 5, 6, 7, 8
1244A	4, 5, 6, 7, 8
1306A	5, 6, 7, 8
1338A	6, 7, 8
1347A	7, 8
1409A	8

### 7-5. MANUAL CHANGE INSTRUCTIONS.

#### CHANGE 1

Table 6-2,

A9: Change to HP Part No. 01805-61601; Qty 1; CABLE ASSY: DELAY LINE; Mfr Code 28480, Mfr Part No. 01805-61601.

#### CHANGE 2

Table 6-2,

Delete: A3C13.  
A6U1: Change to HP Part No. 5081-3018; Qty 2; IC: CONTROL; Mfr Code 28480, Mfr Part No. 5081-3018 (refer to HP Service Note 1805A-1).  
A6U2: Change to HP Part No. 5081-3018; IC: CON-

TROL; Mfr Code 28480, Mfr Part No. 5081-3018 (refer to HP Service Note 1805A-1).

Figure 8-19, schematic 7,  
Delete: A3C13.

#### CHANGE 3

Table 6-2,

Delete: A1MP1.  
A1S1: Change to HP Part No. 3101-1695; Qty 1; PUSHBUTTON SWITCH ASSY; Mfr Code 28480, Mfr Part No. 3101-1695.  
Delete: A2MP1.  
A2S1: Change to HP Part No. 3101-1696; Qty 1; PUSHBUTTON SWITCH ASSY; Mfr Code 28480, Mfr Part No. 3101-1696.

#### CHANGE 4

Table 6-2,

Delete: A2R16.  
Delete: A2VR2.  
Figure 8-17, schematic 6,  
Delete: A2R16 and A2VR2.

#### CHANGE 5

Table 6-2,

A8: Change to HP Part No. 01805-66508; Qty 1; BOARD ASSY: OUTPUT; Mfr Code 28480, Mfr Part No. 01805-66508.  
A9: Change to HP Part No. 01805-61605; Qty 1; CABLE ASSY: DELAY LINE; Mfr Code 28480, Mfr Part No. 01805-61605.  
MP13: Change to HP Part No. 01805-00202; Qty 1; PANEL: SUB; Mfr Code 28480, Mfr Part No. 01805-00202.  
R1: Change to HP Part No. 0811-3151; Qty 1; R: FXD WW 140 OHM 1% 3W; Mfr Code 28480, Mfr Part No. 0811-3151.  
Delete: W2 and W3.  
Delete: A8C5.  
Figure 8-13, schematic 4,  
Delete: A8C5.

#### CHANGE 6

Table 6-2,

MP19: Change to HP Part No. 01805-60101; Qty 1; CHASSIS ASSY; Mfr Code 28480, Mfr Part No. 01805-60101.  
MP24: Change to HP Part No. 01805-04102; Qty 1; COVER: PREAMPL; Mfr Code 28480, Mfr Part No. 01805-04102.

**CHANGE 7**

Table 6-2,

A6C33: Change to HP Part No. 0160-3567; C: FXD CER 10.0 PF 5% 100 VDCW; Mfr Code 72982, Mfr Part No. 8101-100-C0G-100J.

A6C34: Change to HP Part No. 0160-3567; C: FXD CER 10.0 PF 5% 100 VDCW; Mfr Code 72982, Mfr Part No. 8101-100-C0G-100J.

Delete: A6L13 and A6L14.

A7C7: Change to HP Part No. 0160-3647; Qty 1; C: FXD CER 22 PF 5% 100 VDCW (FACTORY SELECTED); Mfr Code 72982, Mfr Part No. 8111-A112-C0G-220J.

A8C4: Change to HP Part No. 0160-2240; Qty 1; C: FXD 2.0 PF 500 VDCW (FACTORY SELECTED); Mfr Code 72982, Mfr Part No. 301-000-C0K0-209C.

Figure 8-9, schematic 2,  
A6C33: Change value to 10.0 PF.  
A6C34: Change value to 10.0 PF.  
Delete: A6L13 and A6L14.

Figure 8-13, schematic 4,  
A7C7: Change value to 22 PF.  
A8C4: Change value to 2 PF.

**CHANGE 8**

Table 6-2,

A9: Change to HP Part No. 01805-61606; Qty 1; CABLE ASSY: DELAY LINE; Mfr Code 28480, Mfr Part No. 01805-61606.

A9T1: Change to HP Part No. 9100-3268; Qty 1; TRANSFORMER; Mfr Code 28480, Mfr Part No. 9100-3268.

**CHANGE 7**

Table 6-2,

A6C33: Change to HP Part No. 0160-3567; C: FXD CER 10.0 PF 5% 100 VDCW; Mfr Code 72982, Mfr Part No. 8101-100-C0G-100J.

A6C34: Change to HP Part No. 0160-3567; C: FXD CER 10.0 PF 5% 100 VDCW; Mfr Code 72982, Mfr Part No. 8101-100-C0G-100J.

Delete: A6L13 and A6L14.

A7C7: Change to HP Part No. 0160-3647; Qty 1; C: FXD CER 22 PF 5% 100 VDCW (FACTORY SELECTED); Mfr Code 72982, Mfr Part No. 8111-A112-C0G-220J.

A8C4: Change to HP Part No. 0160-2240; Qty 1; C: FXD 2.0 PF 500 VDCW (FACTORY SELECTED); Mfr Code 72982, Mfr Part No. 301-000-C0K0-209C.

Figure 8-9, schematic 2,  
A6C33: Change value to 10.0 PF.  
A6C34: Change value to 10.0 PF.  
Delete: A6L13 and A6L14.

Figure 8-13, schematic 4,  
A7C7: Change value to 22 PF.  
A8C4: Change value to 2 PF.

**CHANGE 8**

Table 6-2,

A9: Change to HP Part No. 01805-61606; Qty 1; CABLE ASSY: DELAY LINE; Mfr Code 28480, Mfr Part No. 01805-61606.

A9T1: Change to HP Part No. 9100-3268; Qty 1; TRANSFORMER; Mfr Code 28480, Mfr Part No. 9100-3268.

## SECTION VIII

### SCHEMATICS AND TROUBLESHOOTING

#### 8-1. INTRODUCTION.

8-2. This section contains schematics, repair and replacement information, component-identification illustrations, test conditions, and troubleshooting information.

#### 8-3. SCHEMATICS.

8-4. The schematics are drawn to show the electronic function of the circuits. Any one schematic may include all or part of several different physical assemblies.

8-5. The schematics are numbered in sequence at the lower right-hand corner of each page. These numbers are used to cross reference signal connections between the schematics. At each circuit breaking point, a notation is made of either a signal number or signal name and the schematic number (in bold type) indicating the signals source or destination. To find the source or destination of the signal, turn to the indicated schematic and locate the name or number of the signal in question.

8-6. A table on each schematic lists all components shown on the schematic by reference designation. Reference designators that have been deleted are listed below the table.

8-7. Reference designations used in this manual are in accordance with the provisions of USA Standard Y32.16, Reference Designations for Electrical and Electronics Parts and Equipments. Minor variations from the standard, due to design and manufacturing practices, may be noted.

#### 8-8. REPAIR AND REPLACEMENT.

8-9. The following paragraphs provide procedures for removal and replacement of assemblies, subassemblies, and components. Special servicing instructions for the printed circuit boards are covered later in this section. Section VI provides a detailed parts list for use in ordering replacement parts.

**8-10. OUTPUT TRANSISTOR REMOVAL.** Output transistors Q1 through Q4 are mounted on stand-off insulators and held in place by spring clips. The transistor leads pass through the stand-off insulators and are soldered directly to the back side of output amplifier assembly A8. To remove the output transistors, proceed as follows:

- a. Disconnect spring clip holding transistor.
- b. Unsolder transistor leads and clean holes with desoldering tool.
- c. Remove transistor.

**8-11. ATTENUATOR REMOVAL.** (See figure 8-2.) The following steps provide procedures for removal and replacement of attenuators.

- a. Remove preamplifier shield.
- b. Remove support strut.
- c. Unsolder attenuator output leads from A6Q1 and A6Q4.
- d. Remove two screws securing input end of pre-amplifier board A6.
- e. Remove two screws securing top of front panel assembly.
- f. Remove screw securing side of front panel assembly.
- g. Remove VERT OUT connector J1 from front panel.
- h. Remove front-panel assembly by pulling forward on front panel and working switch boards, A1 and A2, from control board A3.
- i. Remove VOLTS/DIV knob (MP20, MP8, and MP7).
- j. Remove INPUT connectors A10J1 and A11J1.
- k. Remove attenuators from front-panel assembly.

**8-12. ATTENUATOR REPAIR.** Attenuator assemblies A10 and A11 use a thick-film substrate with cam-actuated spring-switch contacts. The following paragraphs provide instructions for disassembly, assembly, and care while handling.

**CAUTION**

Always wear protective cotton gloves (such as HP Part Number 8650-0030) when handling the thick-film substrate. The substrate is extremely susceptible to conduction paths caused by finger prints.

8-13. The only repair that should be attempted is replacement of the thick-film substrate. No other components are replaceable.

#### 8-14. Attenuator Disassembly.

- a. Set coupling switch to GND.
- b. Set VOLTS/DIV to .005.
- c. Remove adjustment cover.
- d. Unsolder output wire from board assembly A6 and input wire from BNC connector.
- e. Release substrate by pulling spring retaining clip toward back of attenuator.
- f. Tilt substrate about 45 degrees (so contacts clear pushrods).
- g. Remove substrate from spring-mounting clips by sliding substrate toward attenuator output.

#### 8-15. Attenuator Assembly.

- a. Hold substrate with contacts down and input facing BNC connector.
- b. Tilt substrate about 45 degrees while sliding it under ground spring and feeding input wire into BNC connector.
- c. Verify grounding springs are seated inside adjustment cover channels (figure 8-1).

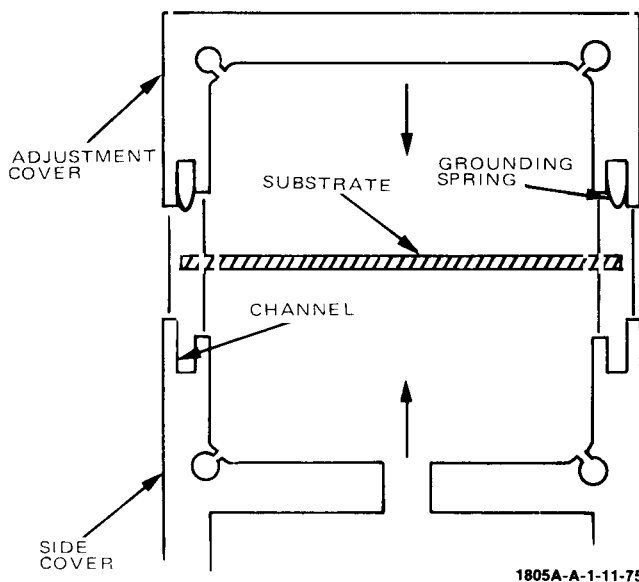

Figure 8-1. Attenuator Assembly

- d. Verify substrate is centered in and flush with side cover channels.

e. Solder input wire to BNC connector and output wire to board assembly A6.

- f. Install adjustment cover.

#### NOTE

Slight pressure applied to the adjustment cover may be necessary to align mounting holes.

#### 8-16. CIRCUIT BOARDS.

**8-17. BOARD CONNECTIONS.** Square-pin connectors are identified on circuit boards by the color code of the connecting wires. Connector pins on plugs and jacks are identified by numbers and/or letters. The letters G, I, O, and Q are omitted.

**8-18. CIRCUIT BOARD REMOVAL.** All circuit boards in this instrument are easily removed for servicing. The 1805A has both the plug-in type and the mounted type circuit boards. The following paragraphs describe the removal procedure for each type of circuit board.

**8-19. Mounted Circuit Board Removal.** There are three mounted circuit boards in Model 1805A: mother board A4, main amplifier A7, and output amplifier A8.

8-20. To remove mother board A4, proceed as follows:

- a. Perform steps a through h of paragraph 8-11.
- b. Remove two screws holding switch board shield MP15.
- c. Remove screw holding power supply bracket MP17.
- d. Remove two screws holding connector A4P1.
- e. Remove two screws holding mother board A4.
- f. Disconnect wires from square-pin connectors on circuit board.
- g. Unsolder wires (+115 Vac) from A4P1.
- h. Remove mother board A4 from Model 1805A chassis.

8-21. To remove main amplifier circuit board A7 and output amplifier circuit board A8, proceed as follows:

- a. Disconnect wires from square pins.
- b. Unsolder wires connecting A7 to circuit board A8.
- c. Remove screws holding circuit board to bracket.
- d. Remove circuit board.

**NOTE**

When installing circuit board A8, align transistor leads on back side of A8 with Q1 through Q4 transistor leads. Gently push board onto transistor leads until board standoffs contact bracket; then fasten.

**8-22. Plug-in Circuit Board Removal.** There are five plug-in circuit boards in the 1805A: top switch board A1, bottom switch board A2, control board A3, power supply board A5, and preamplifier board A6.

8-23. To remove top switch board A1 and bottom switch board A2, proceed as follows:

- a. Perform steps a through h of paragraph 8-11.
- b. Unsolder wires from circuit board.

8-24. To remove control board A3, proceed as follows:

- a. Perform steps a through h of paragraph 8-11.
- b. Remove two screws holding switch board shield MP15.
- c. Remove control board A3 from mother board socket XA3.

8-25. To remove power supply board A5, proceed as follows:

- a. Remove two screws holding power supply bracket MP17.
- b. Remove power supply board A5 from mother board socket XA5.

8-26. To remove preamplifier board A6, proceed as follows:

- a. Remove preamplifier shield.
- b. Remove support strut.
- c. Unsolder attenuator output leads from A6Q1 and A6Q4.
- d. Remove four screws holding preamplifier board A6.

e. Disconnect wires from square pins.

f. Remove preamplifier board A6 from mother board socket A4XA6.

**8-27. SEMICONDUCTOR REPLACEMENT.** When removing a semiconductor, use long-nosed pliers as a heat sink between the device and the soldering iron. When replacing a semiconductor, ensure sufficient lead length to dissipate the soldering heat by using the same length of exposed lead as was used for the original part.

**8-28. INTEGRATED CIRCUIT REPLACEMENT.** The integrated circuits in this instrument are of the plug-in type. Remove a plug-in IC with a straight pull away from the board. When replacing an IC, note the mark or notch (on one end of the IC) used for orientation.

**8-29. TROUBLESHOOTING.**

**WARNING**

Read the Safety Summary at the front of this manual before troubleshooting the instrument.

8-30. The most important prerequisite for successful troubleshooting is understanding how the instrument is designed to operate and correct use of front-panel controls. Suspected malfunctions may be caused by improper control settings or circuit connections such as no vertical display when coupling switch is set to GND. Before doing the test and/or troubleshooting procedures, read Section III (Operation) for an explanation of controls and connectors and general operating considerations, and Section IV (Principles of Operation) for an explanation of circuit theory.

8-31. If trouble is suspected, visually inspect the instrument. Look for loose or burned components that might suggest a source of trouble. Check to see that all circuit board connections are making good contact and are not shorting to an adjacent circuit. If no obvious trouble is found, check the power supply voltages in the unit. Prior to any extensive troubleshooting, check the external power sources also. Figure 8-3 is a troubleshooting block diagram.

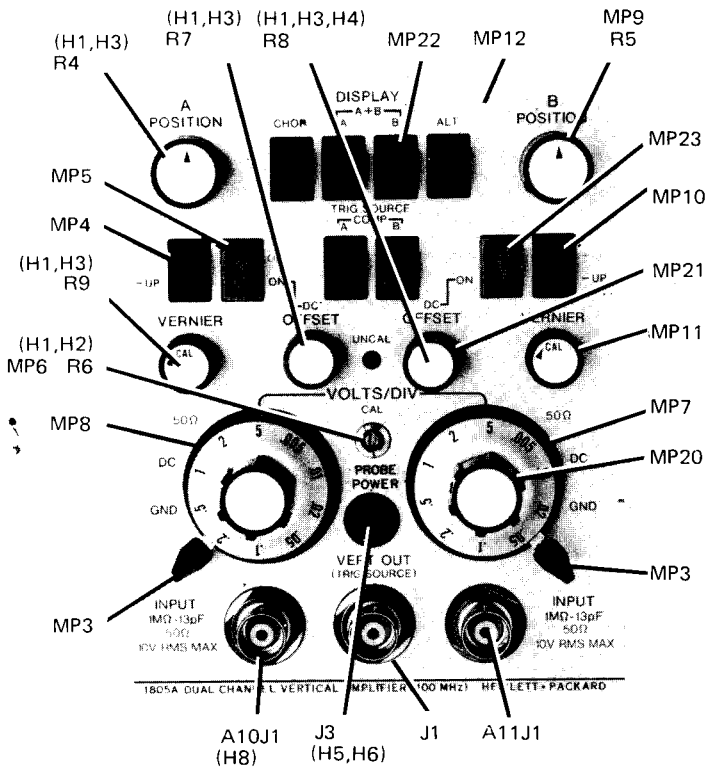

NOTE:  
(H ) denotes mounting hardware

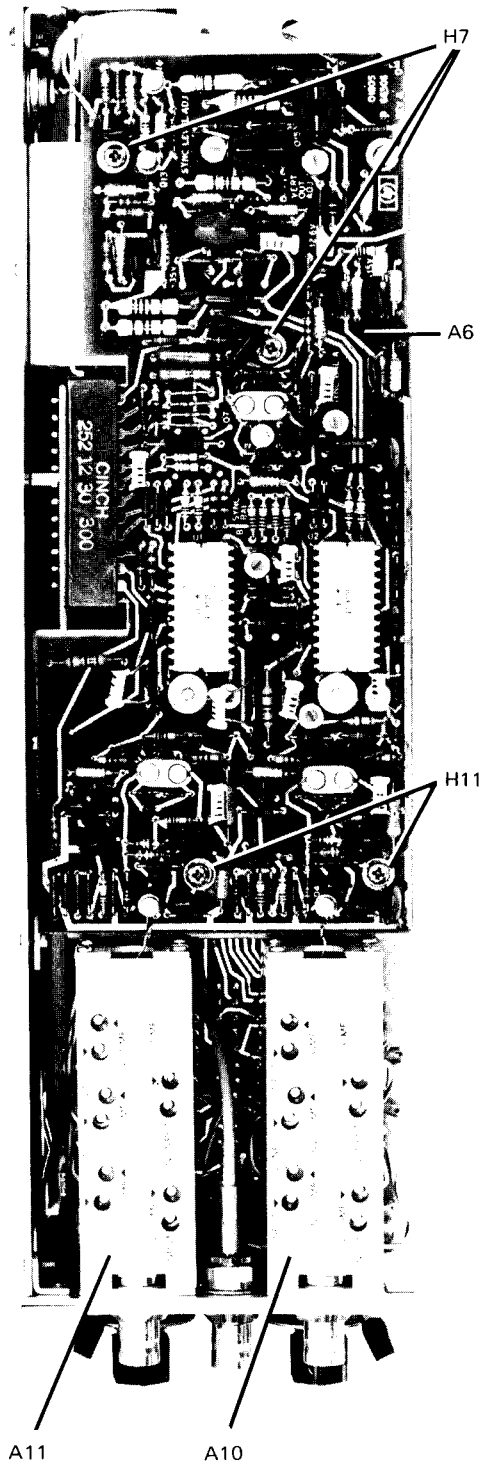
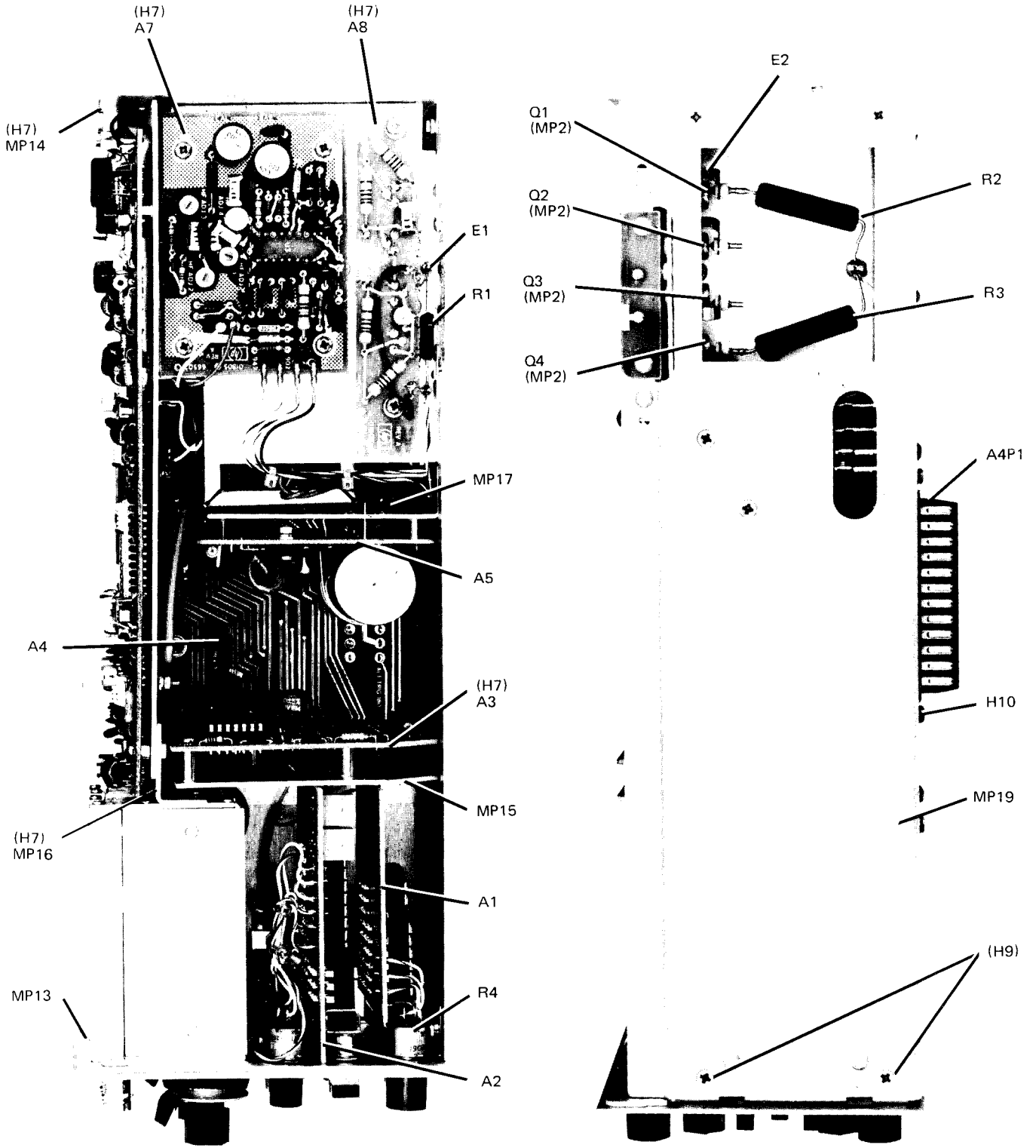

Figure 8-2. Chassis Component and Assembly Locations (Sheet 1 of 2)



NOTE:  
 (H-) denotes mounting hardware

1805A-R-16-02-11-75

Figure 8-2. Chassis Component and Assembly Locations (Sheet 2 of 2)



**VOLTAGE MEASUREMENT CONDITIONS**  
**Figure 8-3.**

**OSCILLOSCOPE**

Focus ..... as necessary  
Intensity..... as necessary  
Horizontal position ..... as necessary  
Mag ..... X1  
Display ..... Internal

**TIME BASE**

Time/division..... 0.5 m/sec  
Trigger ..... Internal  
Mode ..... Auto

**MODEL 1805A**

DISPLAY..... A  
TRIG SOURCE..... A  
Polarity..... + UP  
VOLTS/DIV..... .005  
VERNIER ..... CAL  
POSITION ..... as necessary  
Coupling..... GND

*Figure 8-3. Troubleshooting Block Diagram (Sheet 1 of 2)*

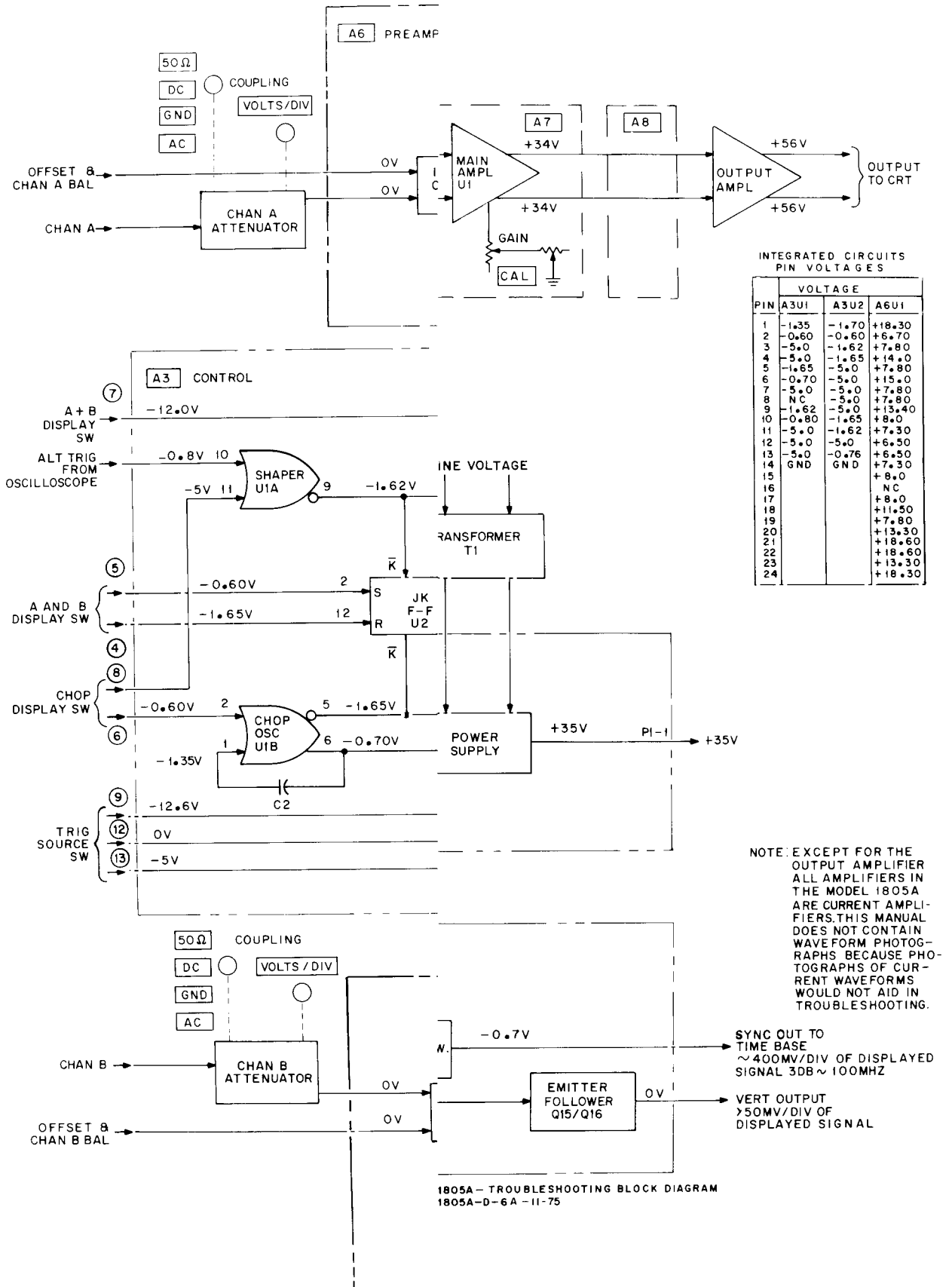
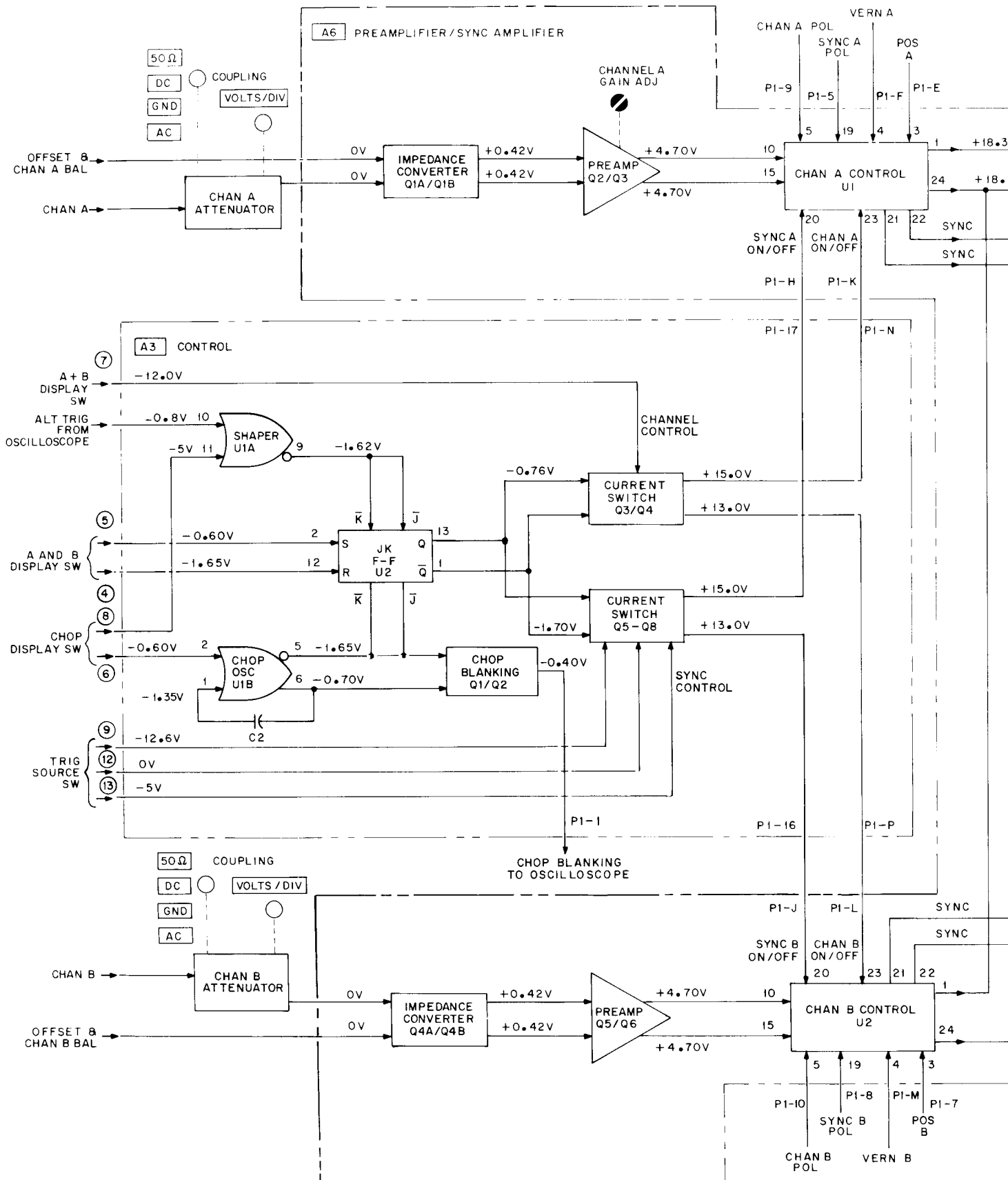

Figure 8-3.  
Troubleshooting Block Diagram (Sheet 2 of 2)  
8-7/(8-8 blank)



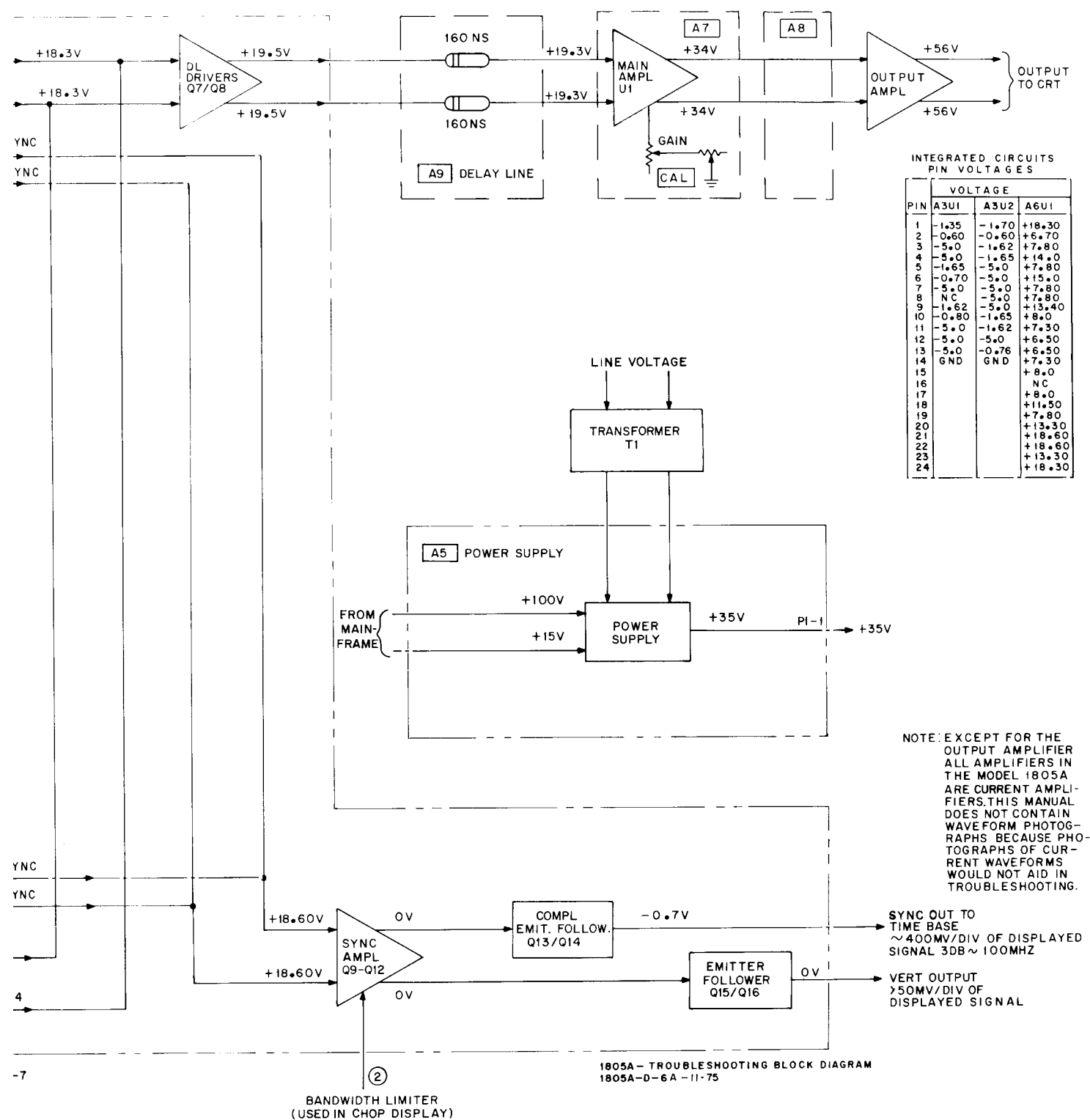

Figure 8-3.  
Troubleshooting Block Diagram (Sheet 2 of 2)  
8-7/(8-8 blank)

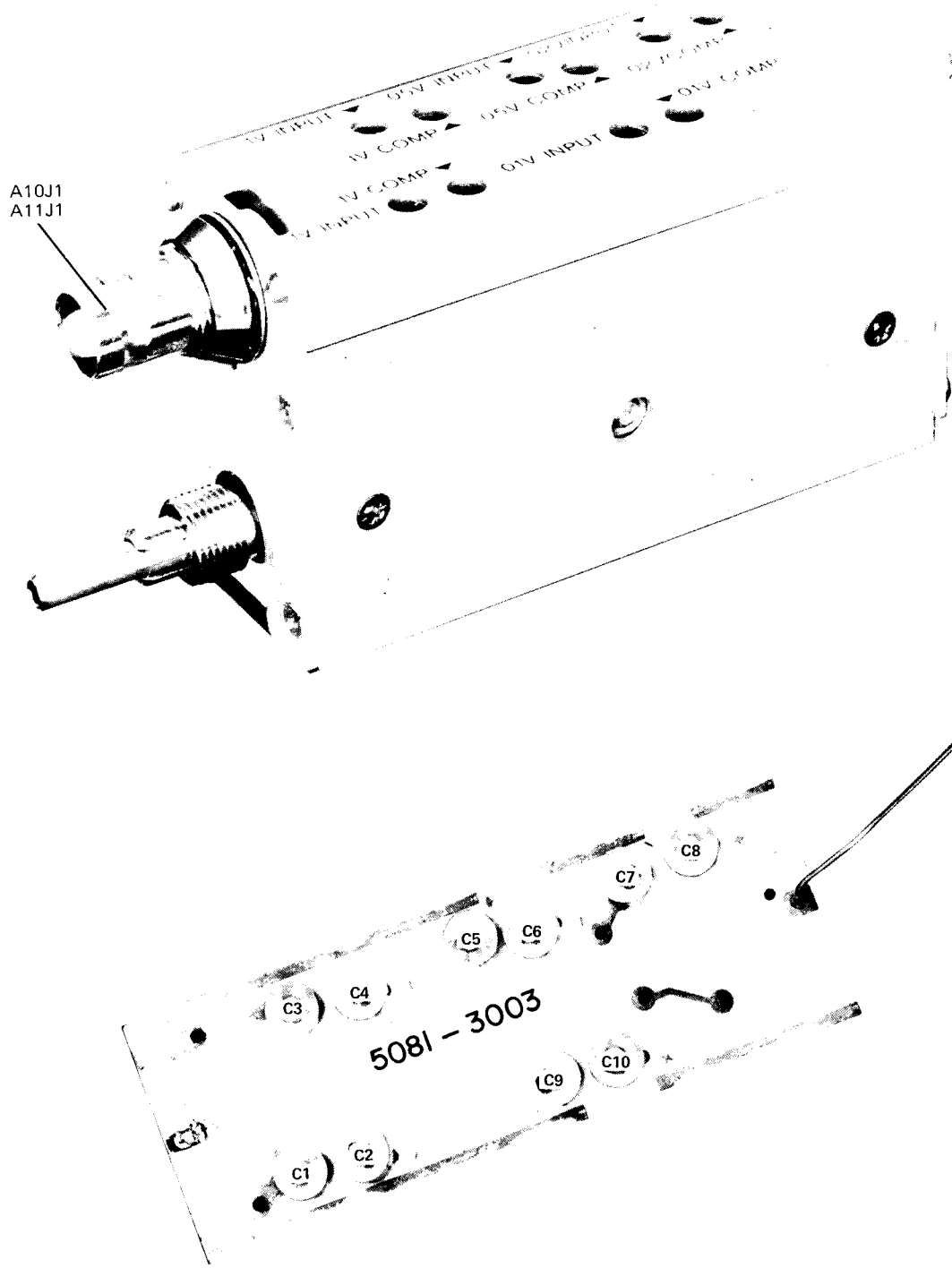
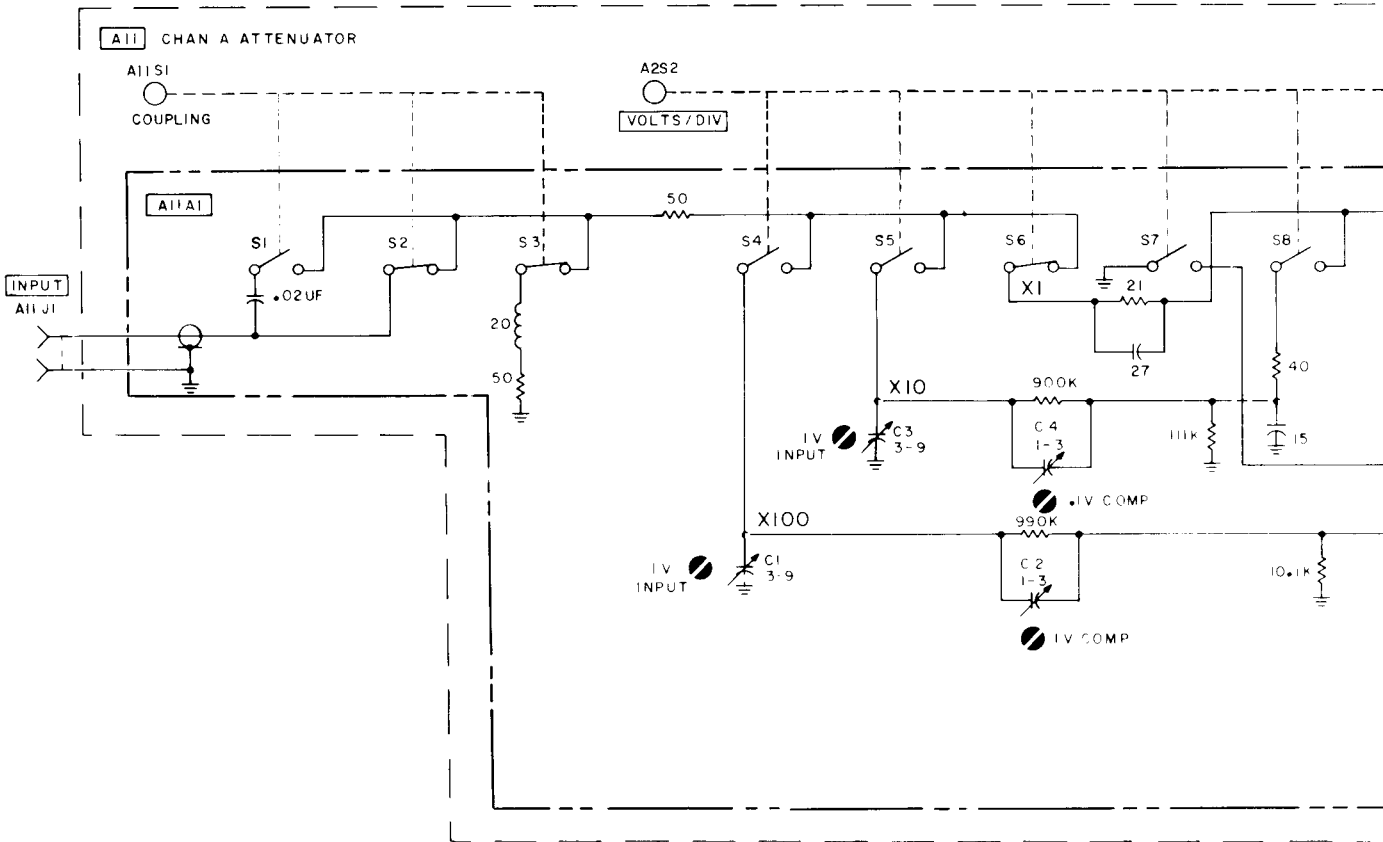
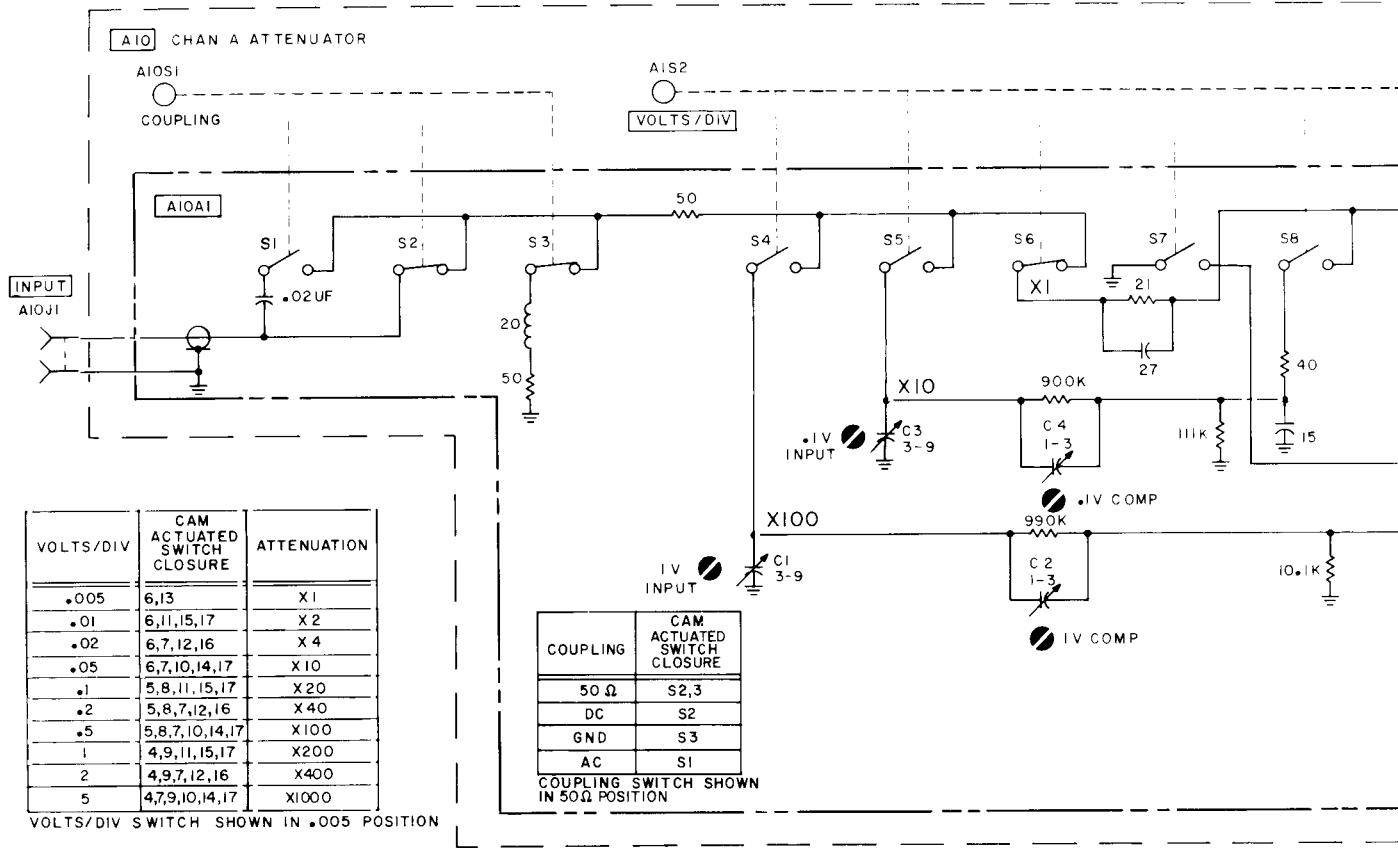
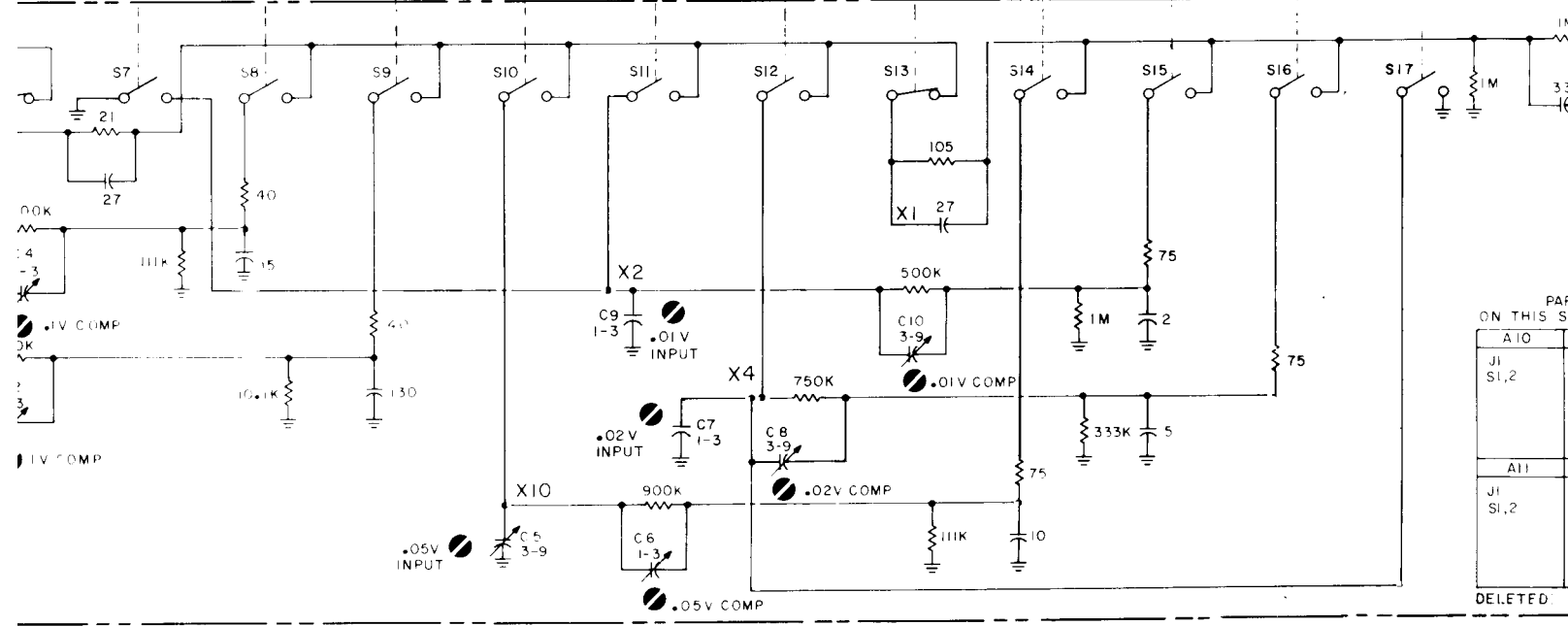
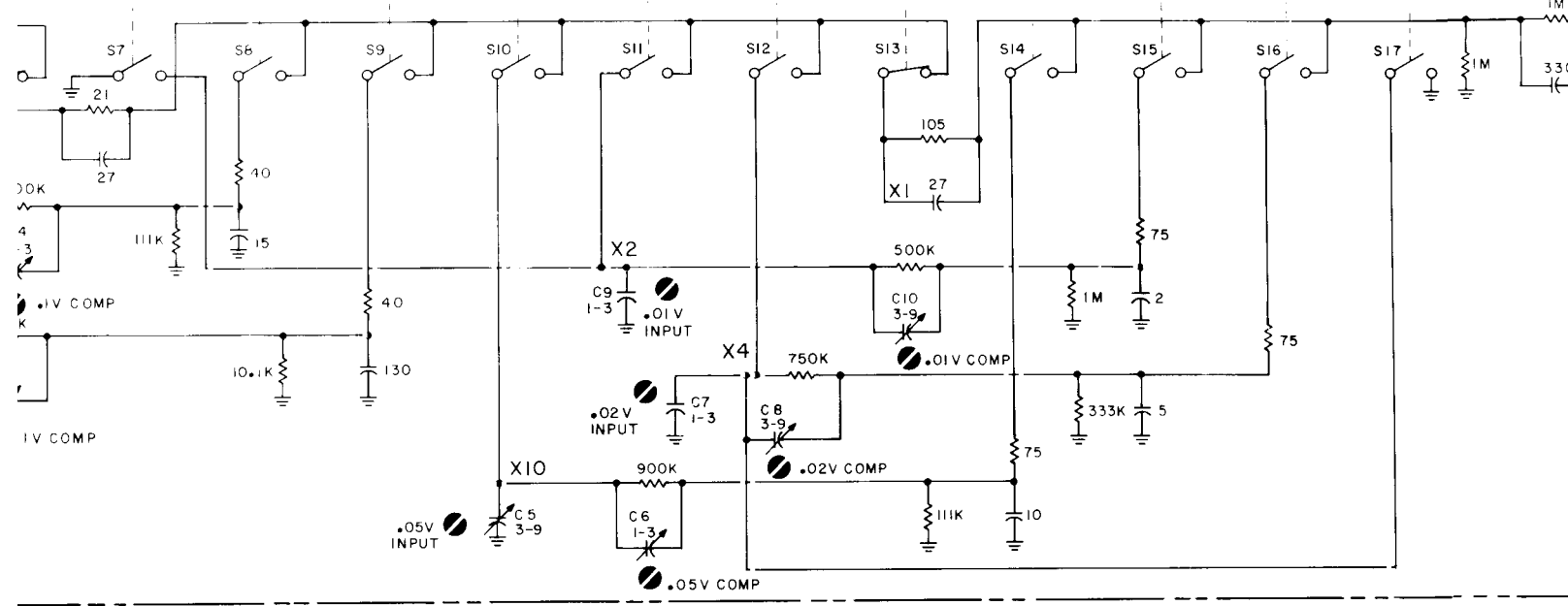

Figure 8-4. Attenuator Component Identification





PARTS LIST

ON THIS SHEET

A10
J1
S1,2
A11
J1
S1,2

DELETED

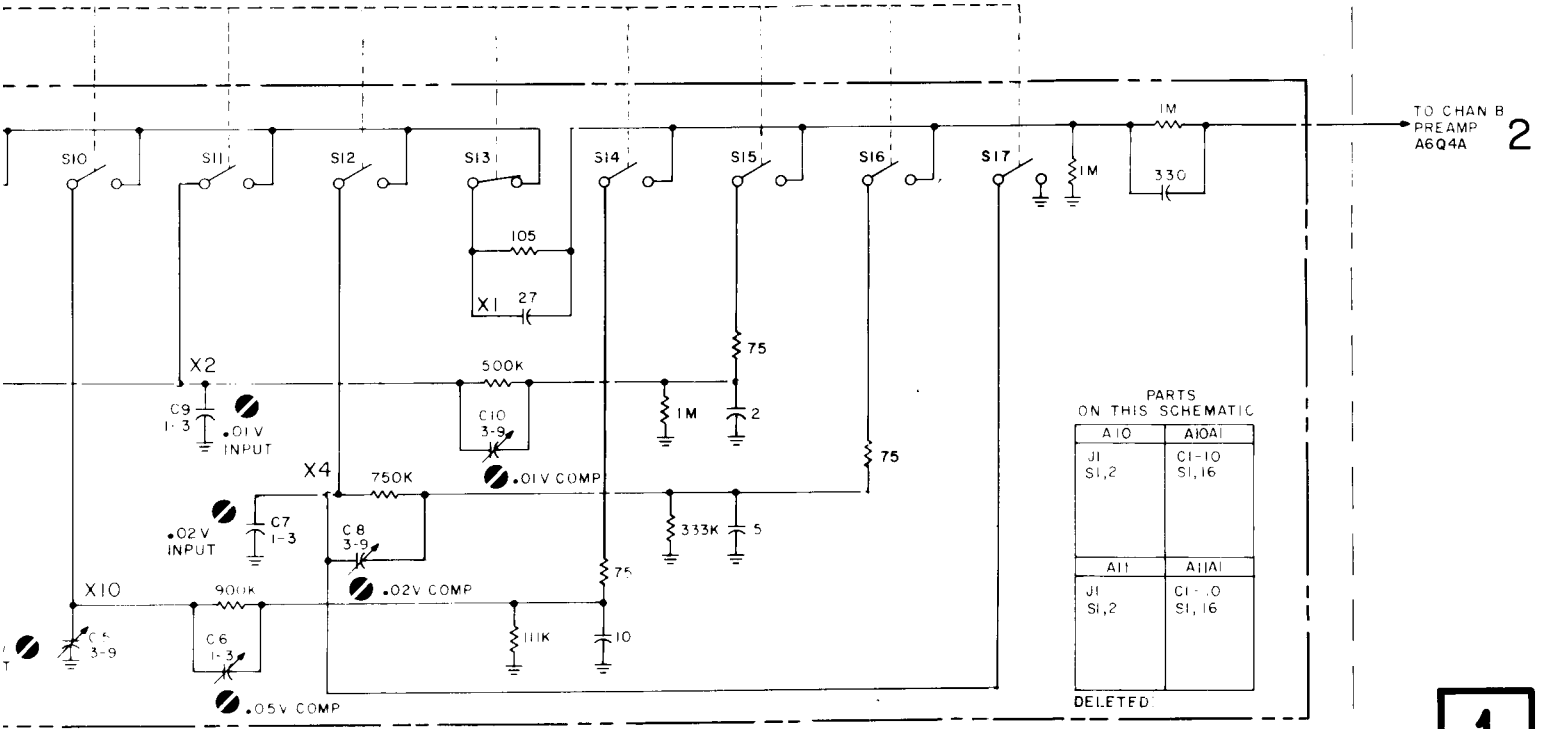
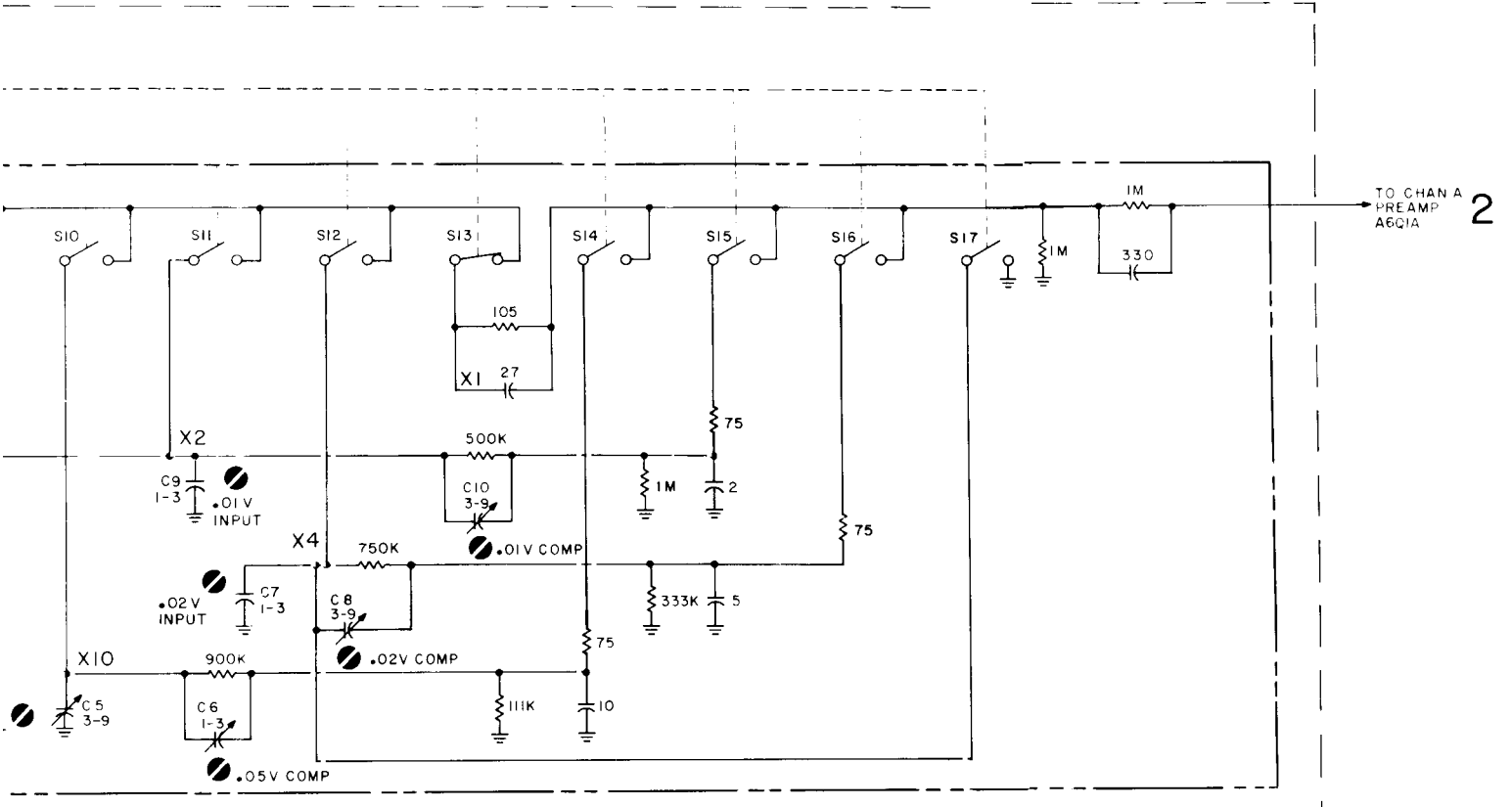

1805A-ATTEN-1233A  
1805A-E-1A-11-75

1

Figure 8-5.  
Attenuator Schematic  
8-9



**VOLTAGE MEASUREMENT CONDITIONS  
SCHEMATIC 2**

**OSCILLOSCOPE**

Focus ..... as necessary  
Intensity..... as necessary  
Horizontal position ..... as necessary  
Mag ..... X1  
Display ..... Internal

**TIME BASE**

Time/division..... 0.5 m/sec  
Trigger ..... Internal  
Mode ..... Auto

**MODEL 1805A**

DISPLAY..... A  
TRIG SOURCE..... A  
Polarity..... + UP  
VOLTS/DIV..... .005  
VERNIER ..... CAL  
POSITION ..... as necessary  
Coupling..... GND

*Figure 8-7. Preamplifier and Sync Amplifier Schematic (Sheet 1 of 2)*

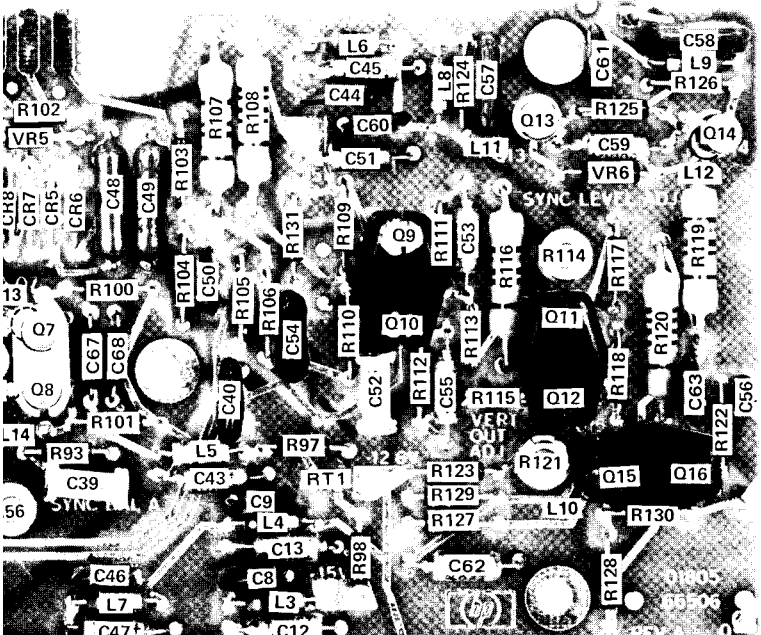
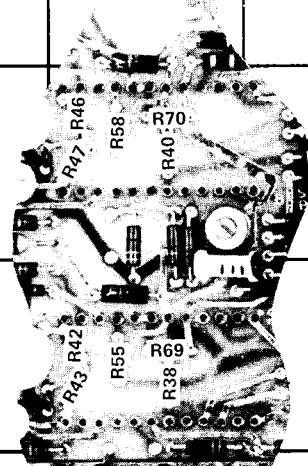
	G	H	I	J	K	L	M	
								1
								2
								3
								4
								5
								6

DETAIL A

REF DESIG	GRID LOC	REF DESIG	GRID LOC	REF DESIG	GRID LOC	REF DESIG	GRID LOC	REF DESIG	GRID LOC	REF DESIG	GRID LOC	REF DESIG	GRID LOC		
R11	A-3	R27	C-4	R44	C-5	R60	D-3	R76	E-2	R92	F-2	R108	G-2	R124	I-2
R12	B-4	R28	C-5	R45	C-2	R61	C-3	R77	F-4	R93	F-4	R109	H-3	R125	I-2
R13	A-1	R29	C-2	R46	L-3	R62	E-5	R78	E-4	R94	F-3	R110	H-3	R126	J-2
R14	B-2	R30	C-3	R47	L-3	R63	D-1	R79	E-4	R95	F-4	R111	H-3	R127	H-4
R15	A-3	R31	C-4	R48	C-3	R64	D-3	R80	E-2	R96	F-2	R112	H-5	R128	I-4
R16	A-1	R32	C-4	R49	C-5	R65	E-5	R81	E-2	R97	H-4	R113	I-3	R129	H-4
R17	A-3	R33	C-2	R50	C-3	R66	E-4	R82	E-3	R98	H-4	R114	I-3	R130	J-4
R18	A-1	R34	C-3	R51	C-4	R67	D-3	R83	E-4	R99	F-3	R115	I-4	R131	H-2
R19	A-3	R35	C-4	R52	C-5	R68	E-3	R84	E-4	R100	G-3	R116	I-3	RT1	H-4
R20	A-1	R36	C-4	R53	C-2	R69	L-4	R85	E-3	R101	G-5	R117	I-3	U1	D-4
R21	B-3	R37	B-5	R54	C-3	R70	L-3	R86	E-3	R102	F-2	R118	I-3	U2	D-3
R22	B-1	R38	L-4	R55	L-4	R71	E-5	R87	E-2	R103	G-2	R119	J-3	VR1	B-3
R23	B-4	R39	B-3	R56	F-4	R72	E-3	R88	E-3	R104	G-3	R120	J-3	VR2	B-2
R24	B-4	R40	L-3	R57	F-4	R73	E-3	R89	F-3	R105	G-3	R121	I-4	VR3	D-4
R25	B-2	R41	L-4	R58	L-3	R74	F-4	R90	F-4	R106	H-3	R122	J-4	VR4	D-2
R26	B-2	R42	L-4	R59	E-3	R75	E-2	R91	F-2	R107	G-2	R123	H-4	VR5	F-2
		R43	L-4											VR6	I-2

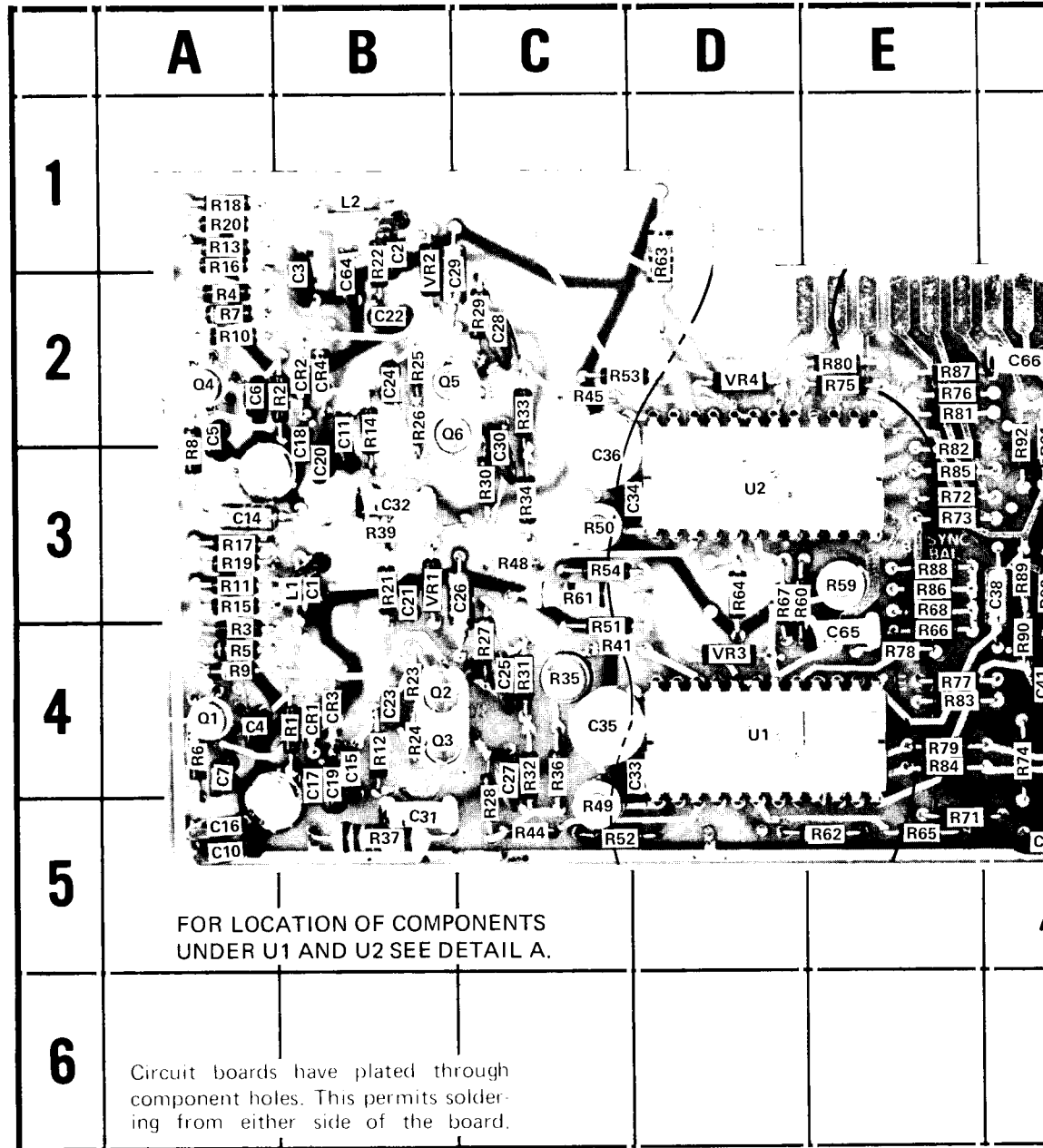

REF DESIG	GRID LOC	REF DESIG	GRID LOC	REF DESIG	GRID LOC	REF DESIG	GRID LOC	REF DESIG	GRID LOC	REF DESIG	GRID LOC	REF DESIG
C1	B-3	C18	B-2	C34	C-3	C51	H-2	C67	G-3	L8	H-2	Q10
C2	B-1	C19	B-4	C35	C-4	C52	H-4	C68	G-3	L9	J-2	Q11
C3	B-2	C20	B-3	C36	C-3	C53	I-3	CR1	B-4	L10	I-4	Q12
C4	A-4	C21	B-3	C37	F-5	C54	H-3	CR2	B-2	L11	I-2	Q13
C5	A-2	C22	B-2	C38	F-3	C55	H-4	CR3	B-4	L12	J-2	Q14
C6	A-2	C23	B-4	C39	G-4	C56	J-4	CR4	B-2	L13	F-3	Q15
C7	A-4	C24	B-2	C40	G-5	C57	I-2	CR5	F-3	L14	F-4	Q16
C8	G-4	C25	C-4	C41	I-4	C58	J-2	CR6	G-3	Q1	A-4	R1
C9	G-4	C26	C-3	C42	F-3	C59	I-2	CR7	F-3	Q2	B-4	R2
C10	A-5	C27	C-4	C43	G-5	C60	H-2	CR8	F-3	Q3	B-4	R3
C11	B-2	C28	C-2	C44	H-2	C61	I-2	L1	B-3	Q4	A-2	R4
C12	H-5	C29	C-1	C45	H-2	C62	I-4	L2	R-1	Q5	B-2	R5
C13	H-4	C30	C-3	C46	G-5	C63	J-4	L3	H-5	Q6	B-2	R6
C14	A-3	C31	B-5	C47	G-6	C64	B-2	L4	H-4	Q7	F-3	R7
C15	B-4	C32	B-3	C48	G-2	C65	E-4	L5	G-5	Q8	F-3	R8
C16	A-5	C33	D-4	C49	G-3	C66	F-2	L6	H-2	Q9	H-3	R9
C17	B-4			C50	G-3			L7	G-6			R10

Figure 8-6. Preamplifier

**VOLTAGE MEASUREMENT CONDITIONS  
SCHEMATIC 2**

**OSCILLOSCOPE**

Focus ..... as necessary  
Intensity..... as necessary  
Horizontal position ..... as necessary  
Mag ..... X1  
Display ..... Internal

**TIME BASE**

Time/division..... 0.5 m/sec  
Trigger ..... Internal  
Mode ..... Auto

**MODEL 1805A**

DISPLAY..... A  
TRIG SOURCE..... A  
Polarity..... + UP  
VOLTS/DIV..... .005  
VERNIER ..... CAL  
POSITION ..... as necessary  
Coupling..... GND

*Figure 8-7. Preamplifier and Sync Amplifier Schematic (Sheet 1 of 2)*

P/O A6 PRE-AMP / SYNC AMPL

IMPEDANCE  
CONVERTER  
Q1A/Q1B

PREAMPLIFIER  
Q2/Q3

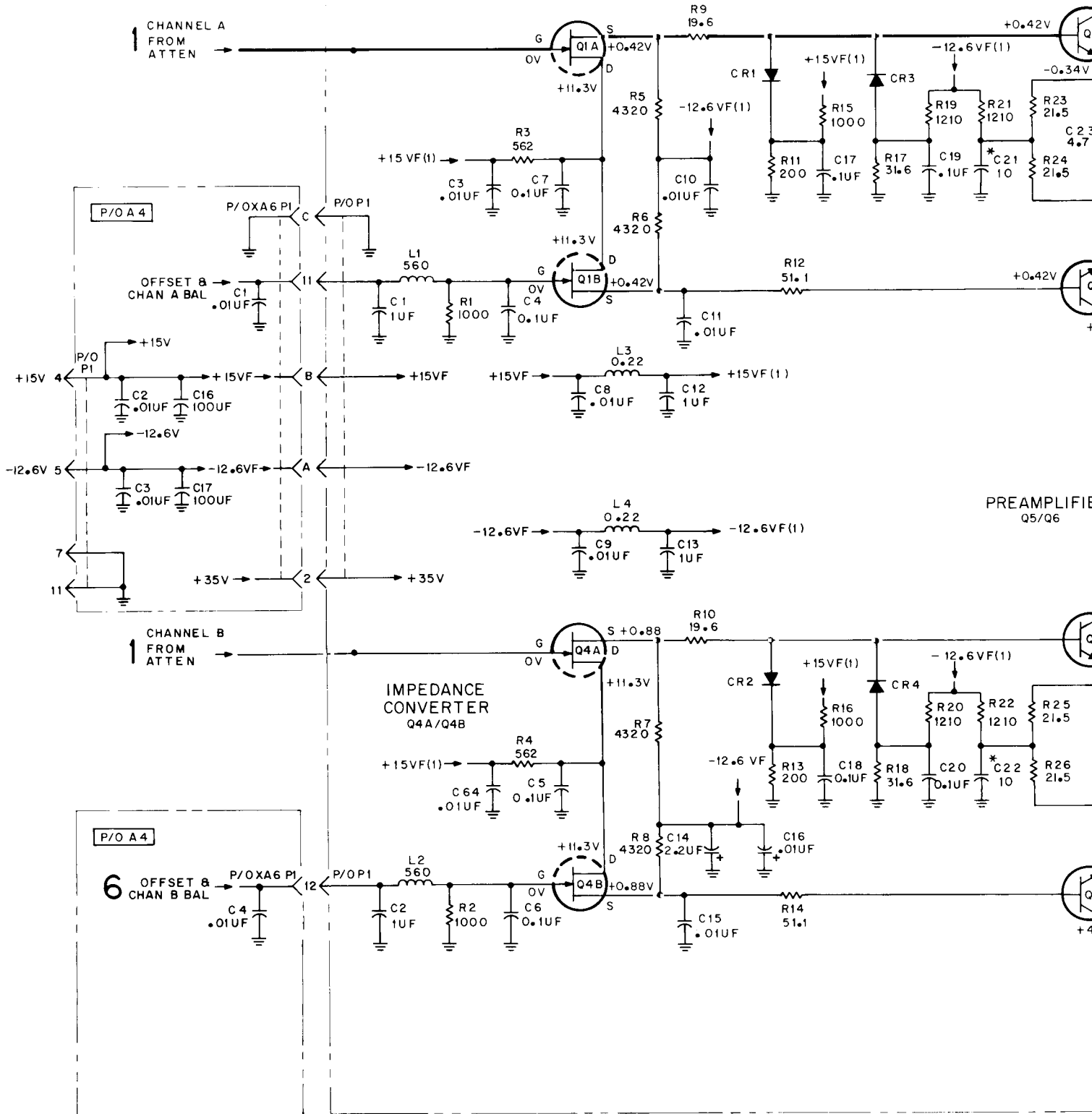

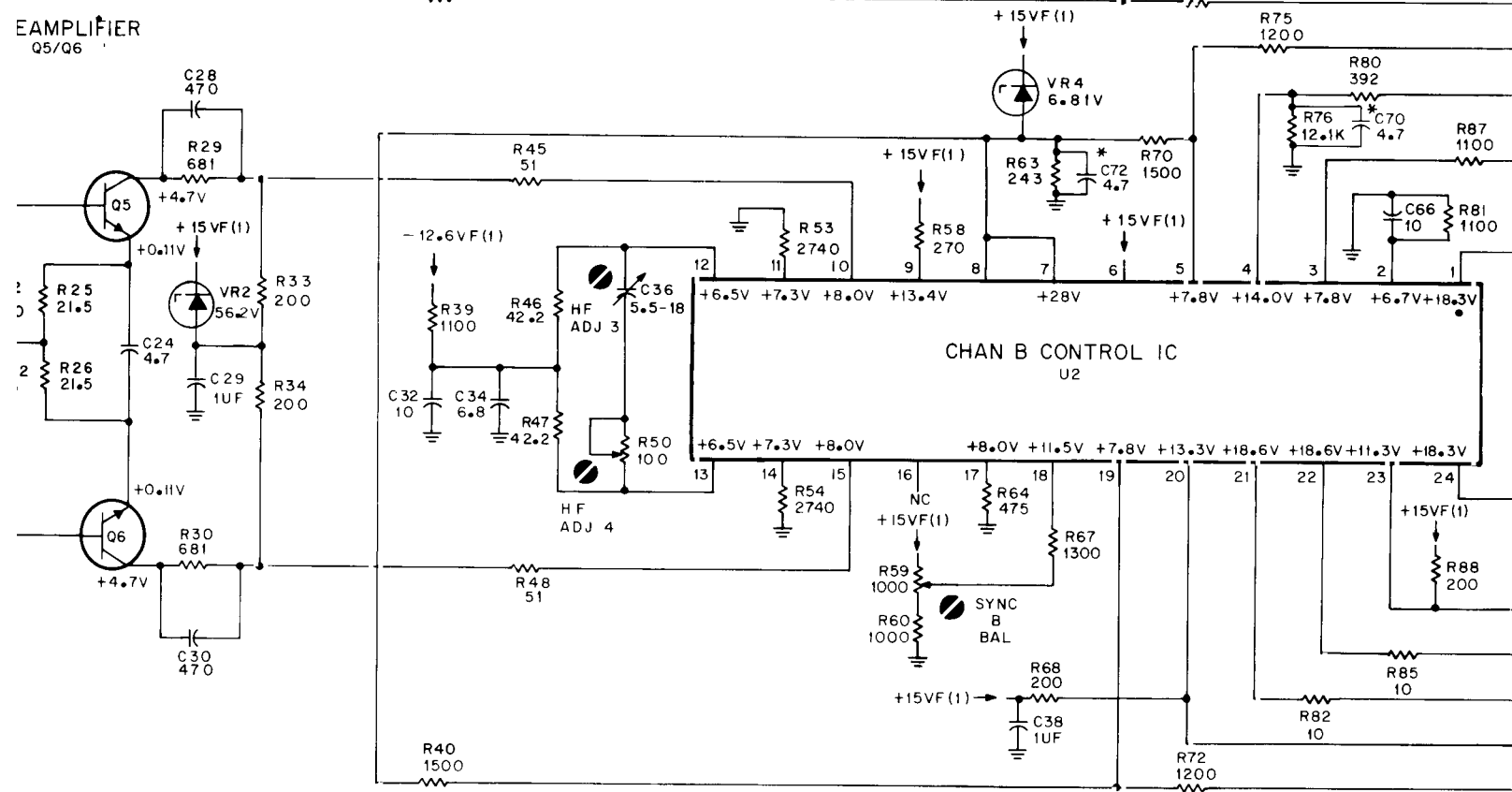
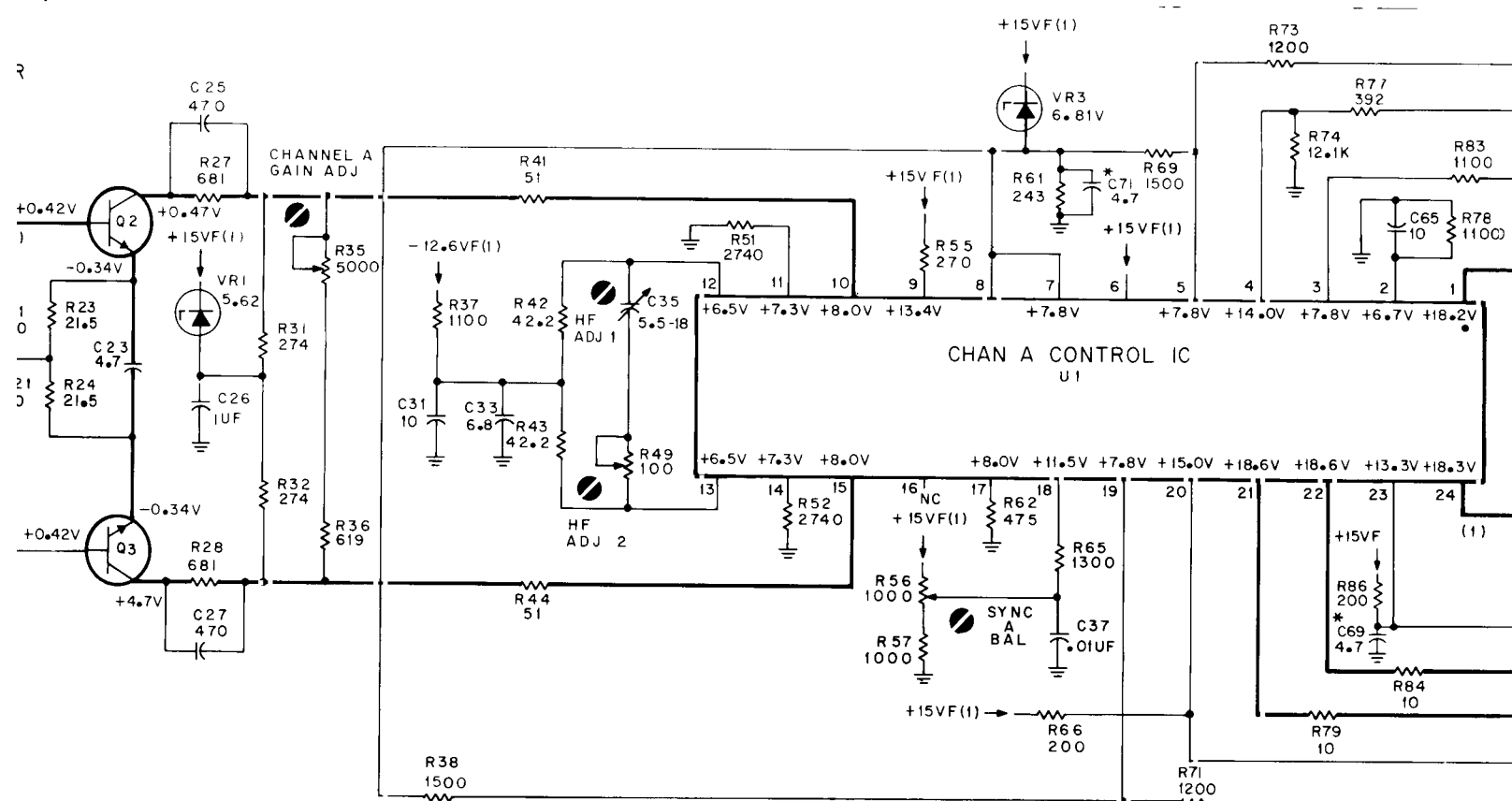

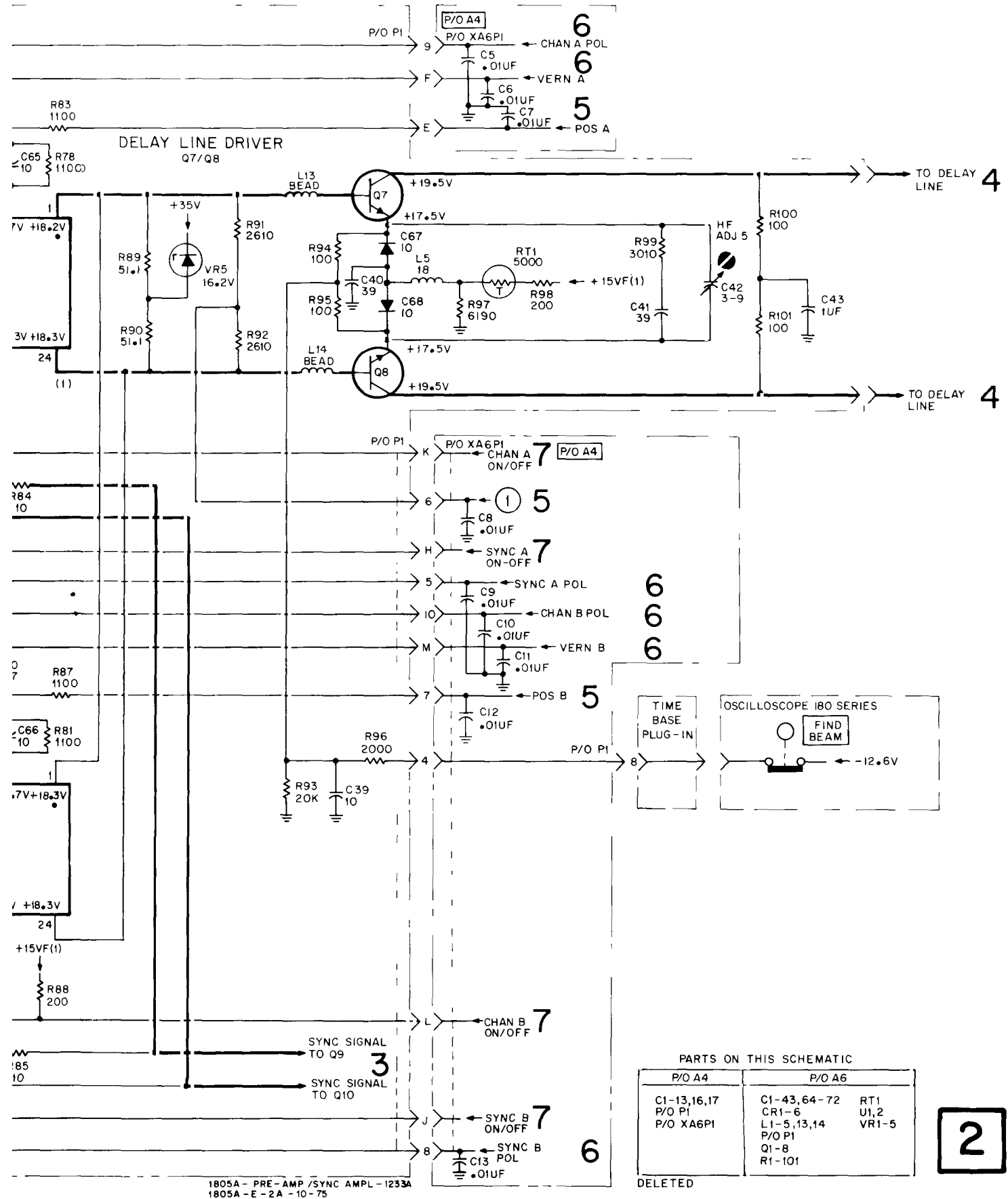

2

Figure 8-7.  
Preamplifier and Sync Amplifier Schematic (Sheet 2 of 2)

**VOLTAGE MEASUREMENT CONDITIONS  
SCHEMATIC 3**

**OSCILLOSCOPE**

Focus ..... as necessary  
Intensity ..... as necessary  
Horizontal position ..... as necessary  
Mag ..... X1  
Display ..... Internal

**TIME BASE**

Time/division ..... 0.5 m/sec  
Trigger ..... Internal  
Mode ..... Auto

**MODEL 1805A**

DISPLAY ..... A  
TRIG SOURCE ..... A  
Polarity ..... + UP  
VOLTS/DIV ..... .005  
VERNIER ..... CAL  
POSITION ..... as necessary  
Coupling ..... GND

*Figure 8-9. Preamplifier and Sync Amplifier Schematic (Sheet 1 of 2)*



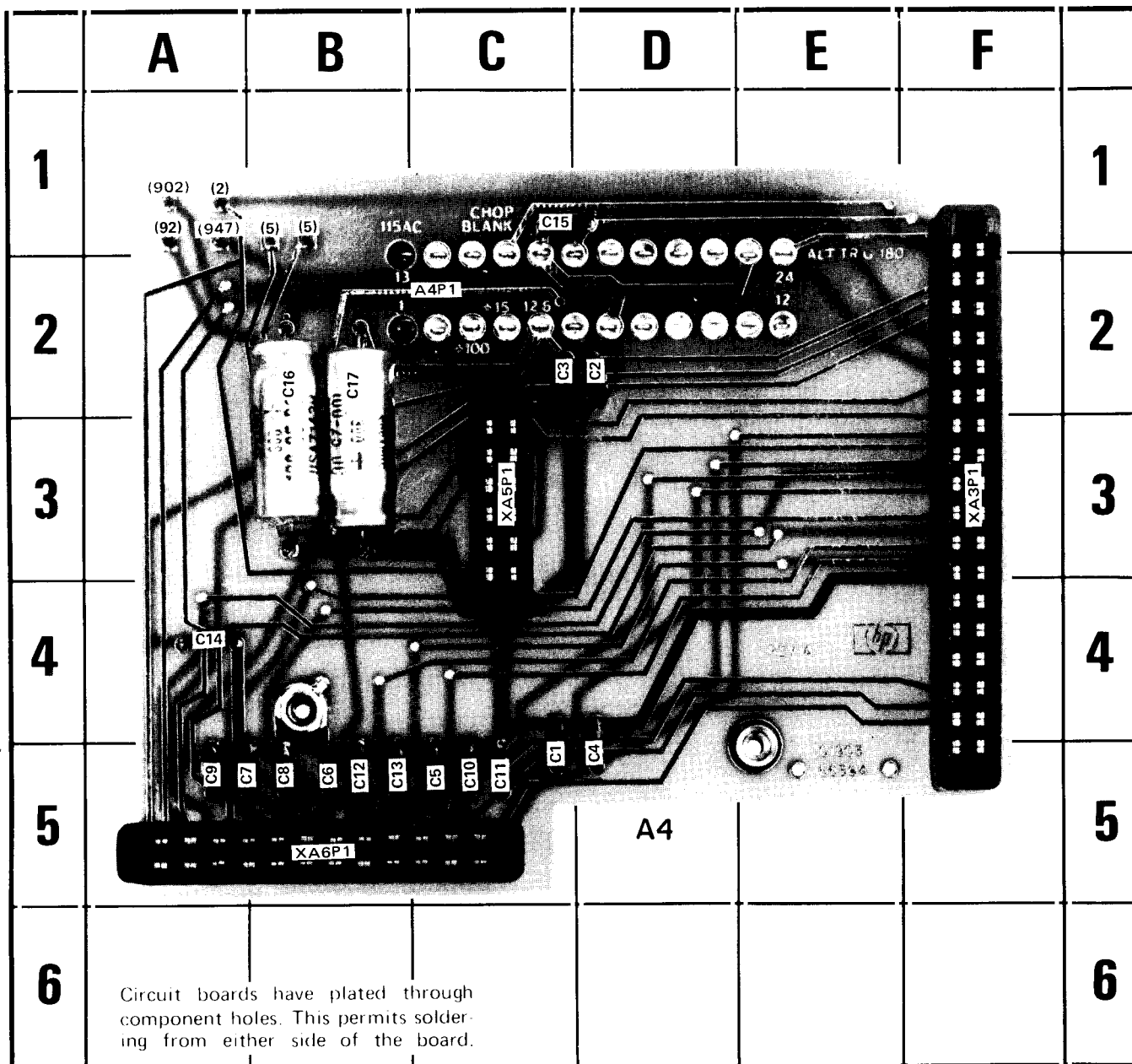

6 Circuit boards have plated through component holes. This permits soldering from either side of the board.

REF DESIG	GRID LOC	REF DESIG	GRID LOC	REF DESIG	GRID LOC
C1	C-5	C6	B-5	C12	B-5
C2	D-2	C7	A-5	C13	B-5
C3	C-2	C8	B-5	C14	A-4
C4	D-5	C9	A-5	C15	C-2
C5	C-5	C10	C-5	C16	B-2
		C11	C-5	C17	B-2

Figure 8-8. Interconnecting Board A4, Component Identification

P/O A6 PREAMP/SYNC AMPL BD

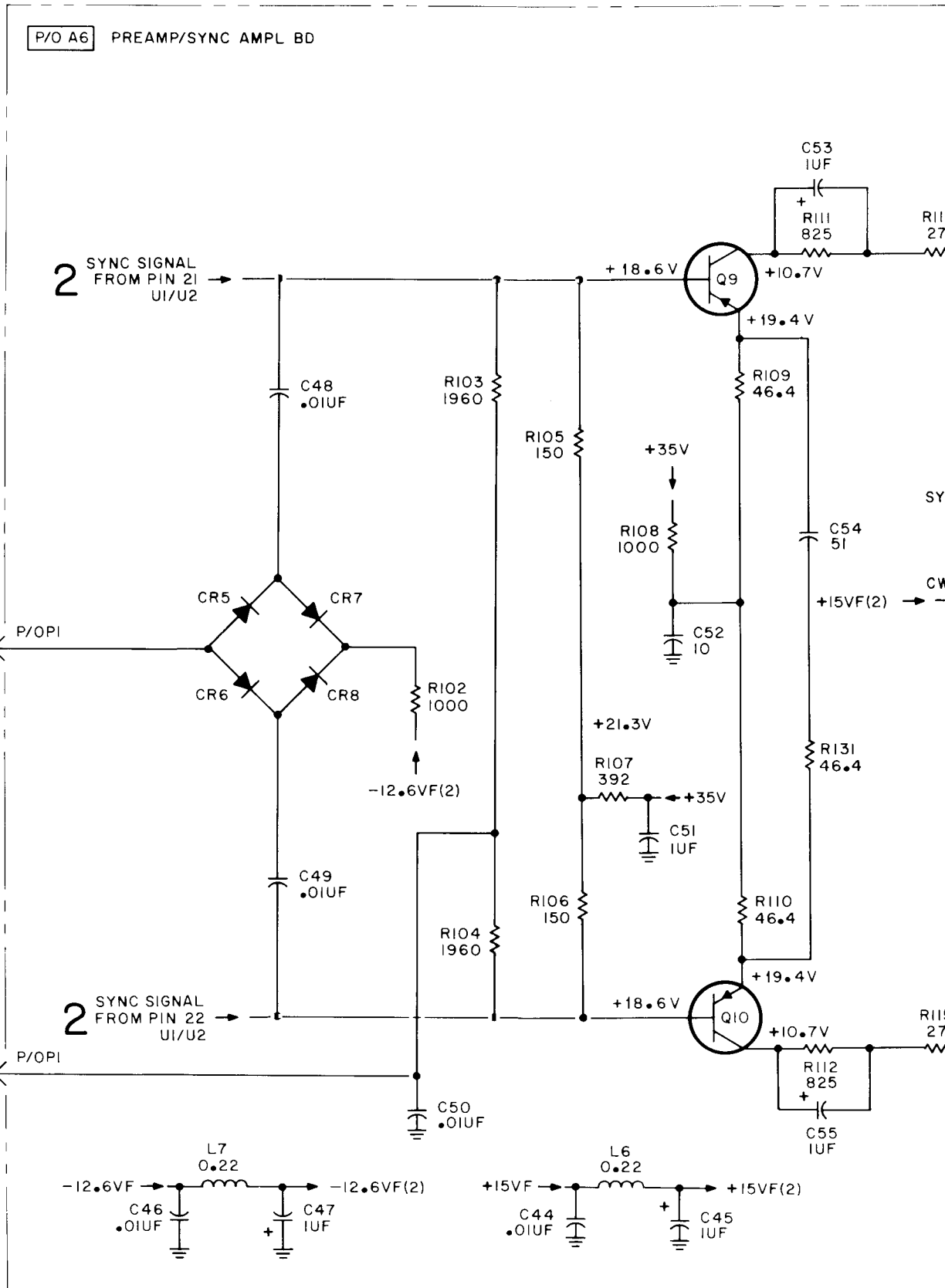
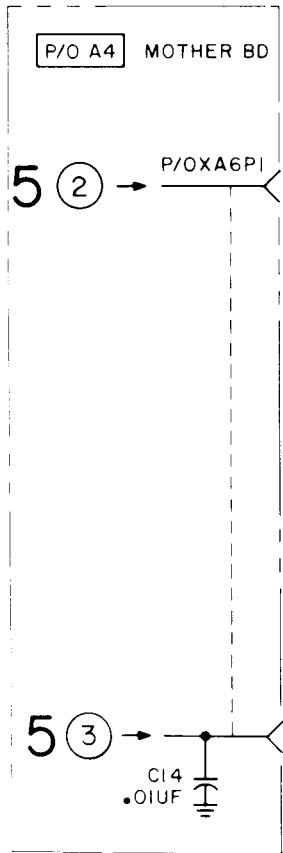

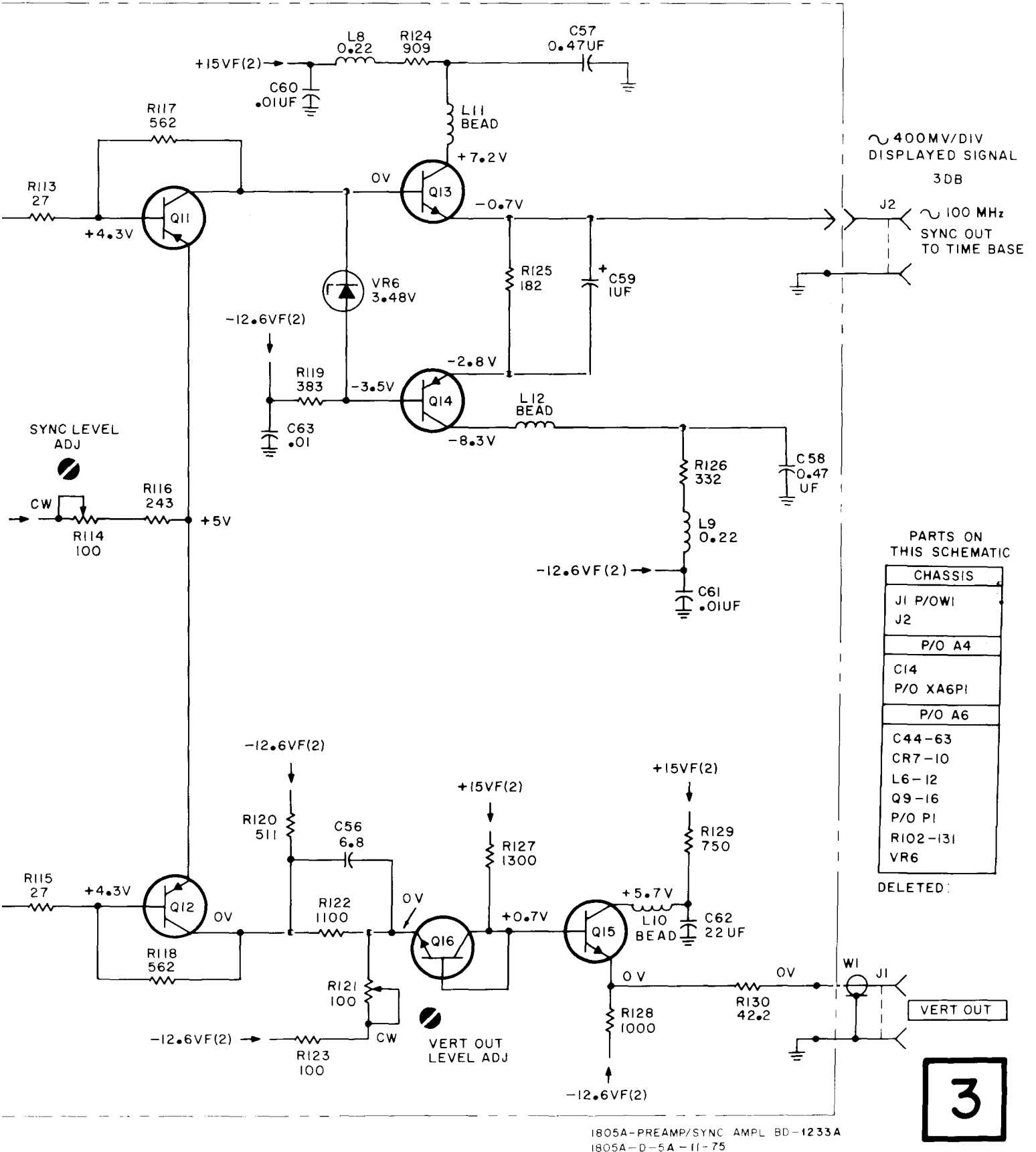

3

Figure 8-9.  
Preamplifier and Sync Amplifier Schematic (Sheet 2 of 2)  
8-13

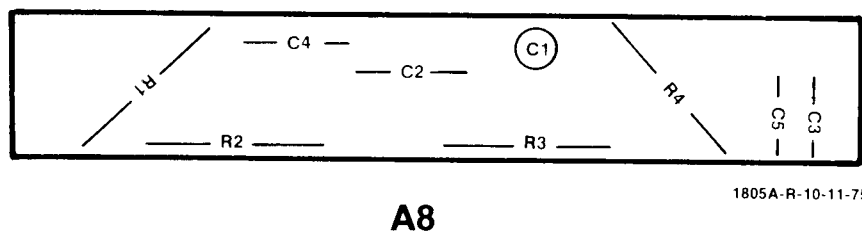

Figure 8-11. Output Amplifier Board A8, Component Identification

**VOLTAGE MEASUREMENT CONDITIONS  
SCHEMATIC 4**

**OSCILLOSCOPE**

Focus ..... as necessary  
 Intensity ..... as necessary  
 Horizontal position ..... as necessary  
 Mag ..... X1  
 Display ..... Internal

**TIME BASE**

Time/division ..... 0.5 m/sec  
 Trigger ..... Internal  
 Mode ..... Auto

**MODEL 1805A**

DISPLAY ..... A  
 TRIG SOURCE ..... A  
 Polarity ..... + UP  
 VOLTS/DIV ..... .005  
 VERNIER ..... CAL  
 POSITION ..... as necessary  
 Coupling ..... GND

Figure 8-12. Output Amplifier Schematic (Sheet 1 of 2)

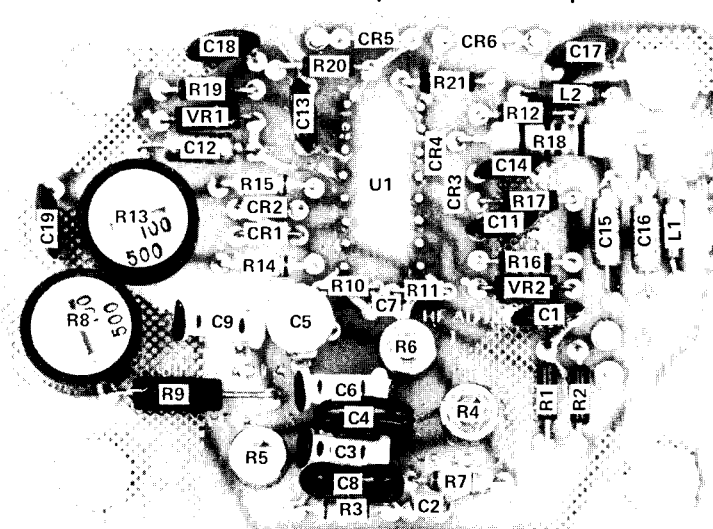
	A	B	C	D	E	F		
1							1	
2							2	
3							(2)+35V (902)+15V (902) TO RI (947) TO CAL	3
4								4
5							A7	5
6	Circuit boards have plated through component holes. This permits soldering from either side of the board.						6	

REF DESIG	GRID LOC	REF DESIG	GRID LOC	REF DESIG	GRID LOC	REF DESIG	GRID LOC	REF DESIG	GRID LOC	REF DESIG	GRID LOC
C1	D-3	C9	C-3	C18	C-2	L1	E-3	R8	B-3	R17	D-3
C2	D-4	C11	D-3	C19	B-3	L2	D-2	R9	B-4	R18	D-2
C3	C-4	C12	C-3	CR1	C-3	R1	D-4	R10	C-3	R19	C-2
C4	C-4	C13	C-2	CR2	C-3	R2	E-4	R11	D-3	R20	C-2
C5	C-3	C14	D-3	CR3	D-3	R3	C-4	R12	D-2	R21	D-2
C6	C-4	C15	E-3	CR4	D-3	R4	D-4	R13	B-3	VR1	C-2
C7	D-3	C16	E-3	CR5	C-2	R5	C-4	R14	C-3	VR2	D-3
C8	C-4	C17	E-2	CR6	D-2	R6	D-4	R15	C-3	U1	C-3
						R7	D-4	R16	D-3		

Figure 8-10. Main Amplifier Board A7, Component Identification

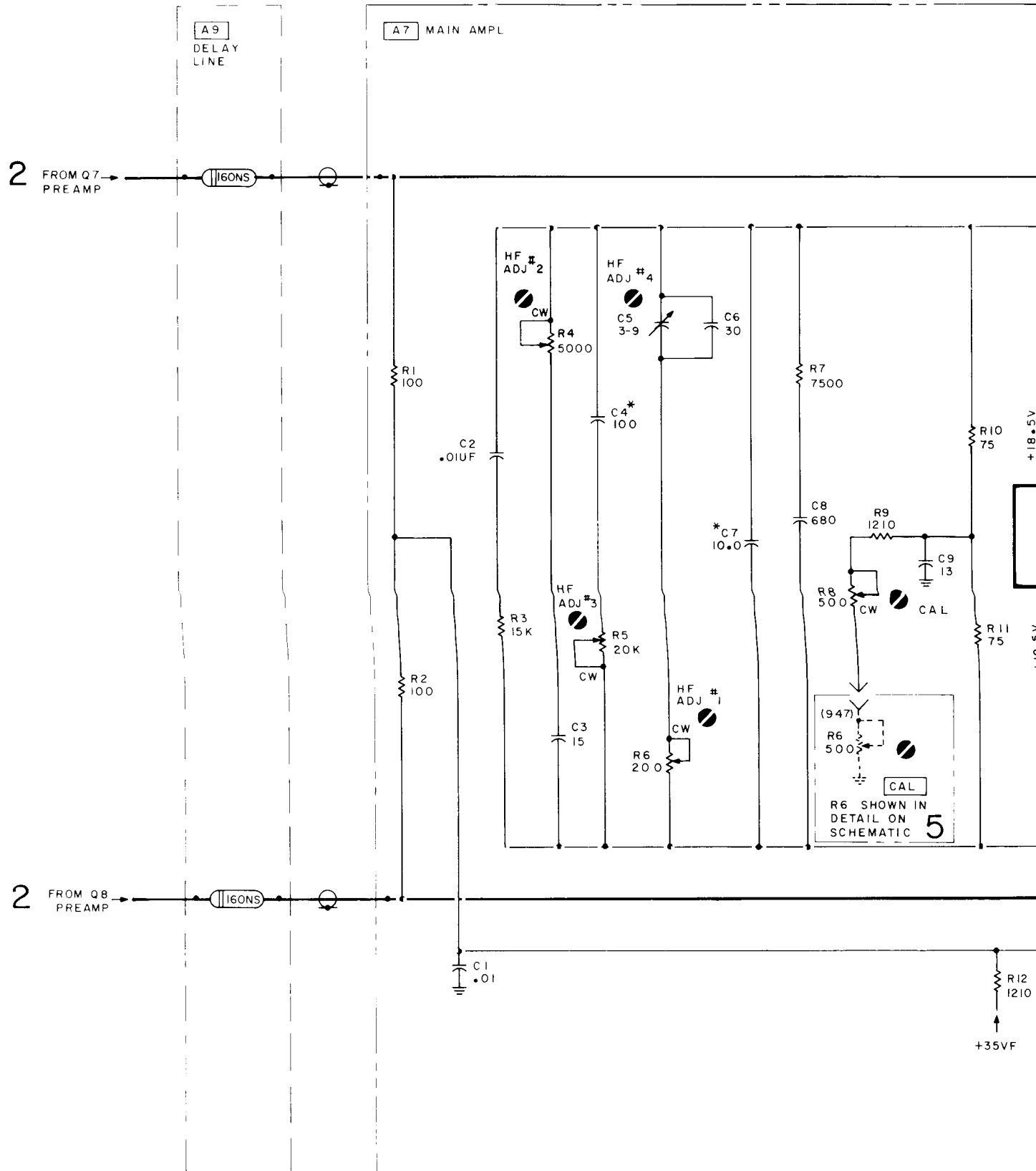

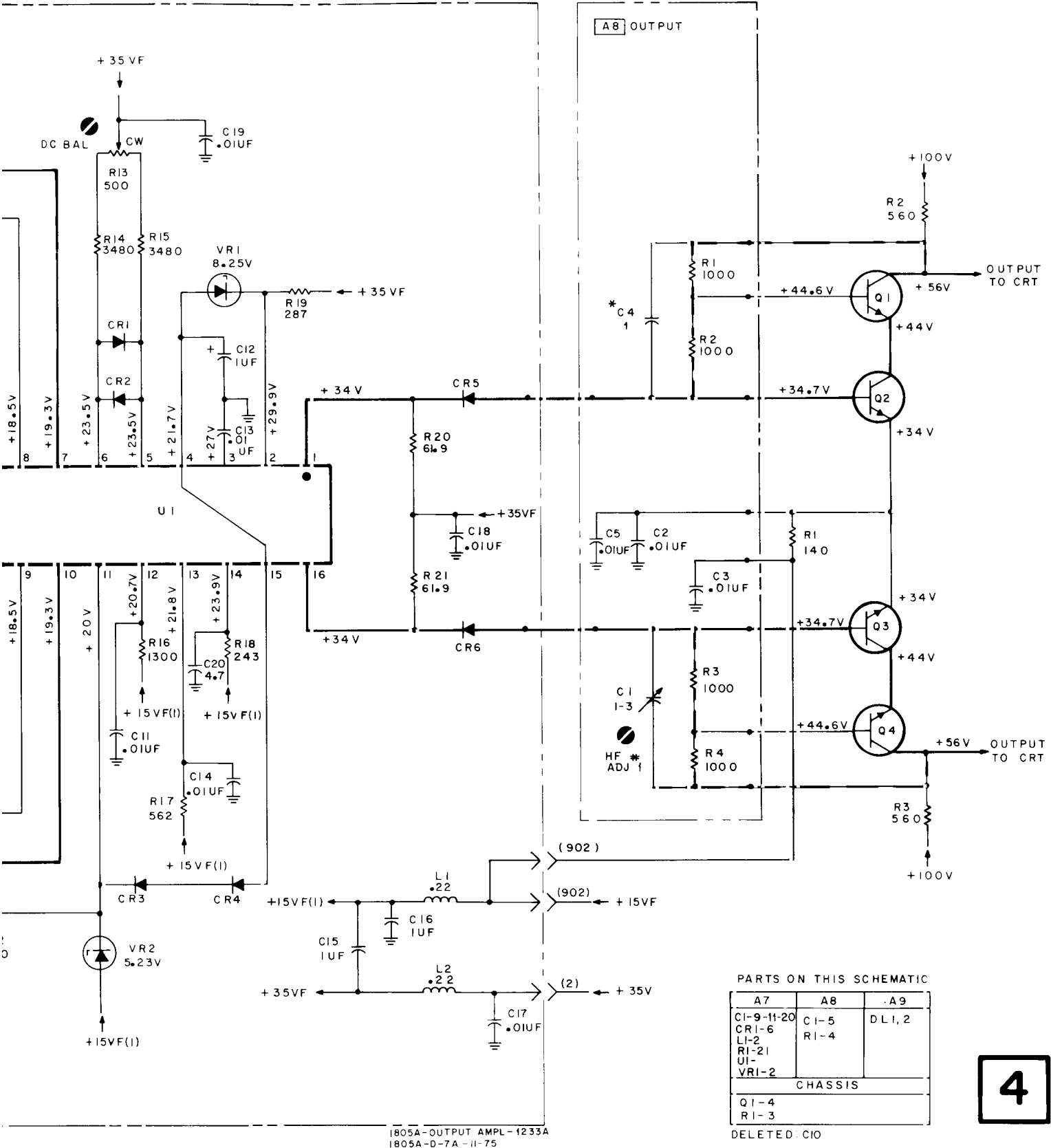

1805A-OUTPUT AMPL-1233A  
1805A-D-7A-II-75



Figure 8-12.  
Output Amplifier Schematic (Sheet 2 of 2)  
8-15

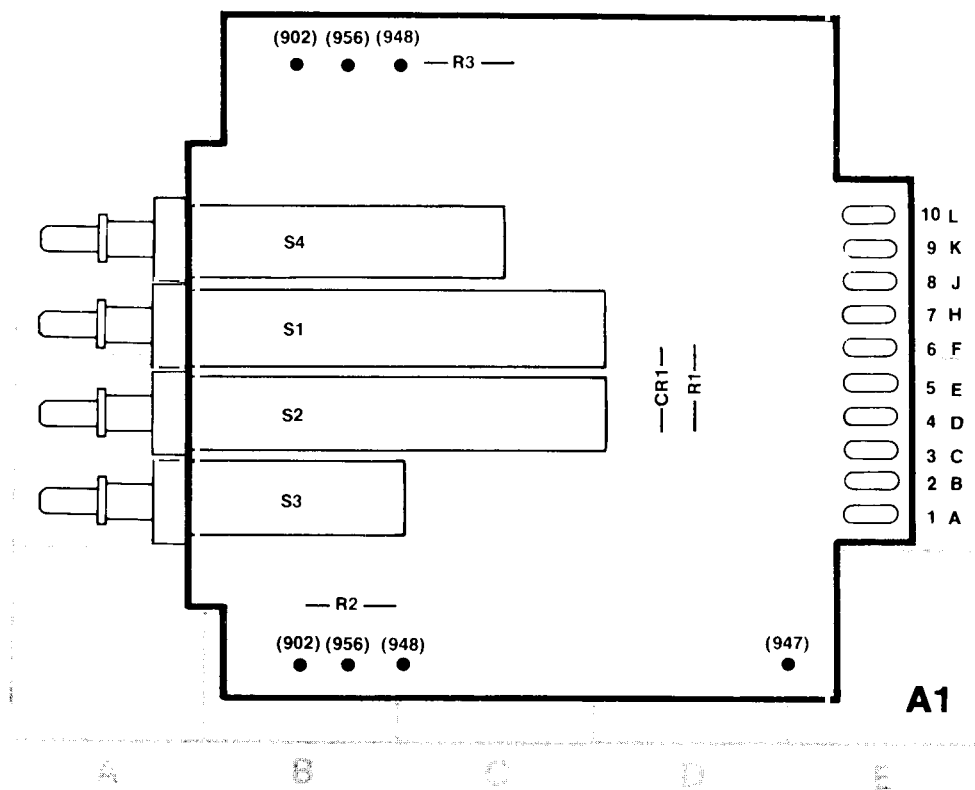

1805A-R-13-11-75

REF DESIG	GRID LOC	REF DESIG	GRID LOC
CR1	D-3	S1	B-2
R1	D-3	S2	B-3
R2	B-4	S3	B-3
R3	C-1	S4	B-2

Figure 8-13. Top Switch Board A1, Component Identification



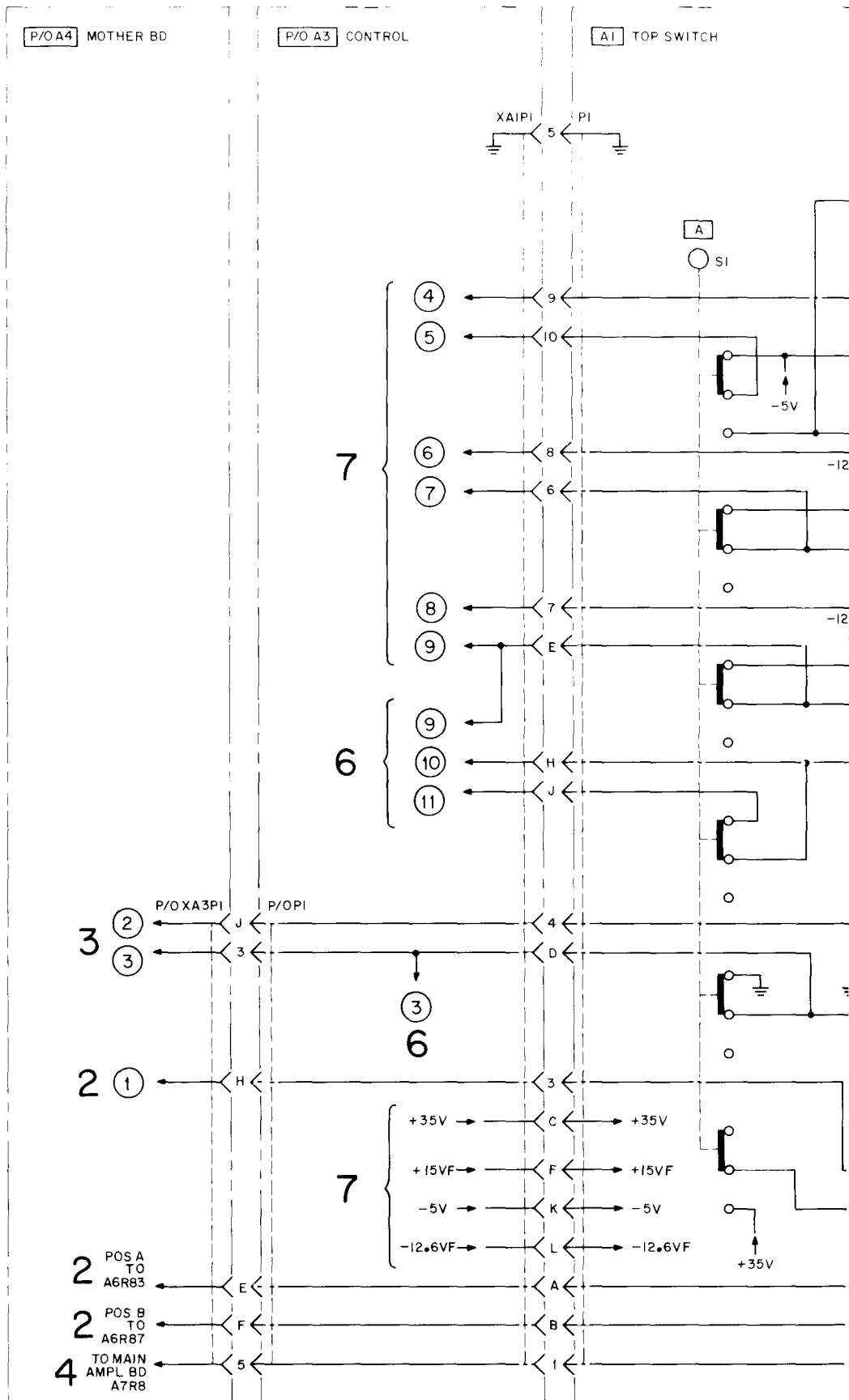

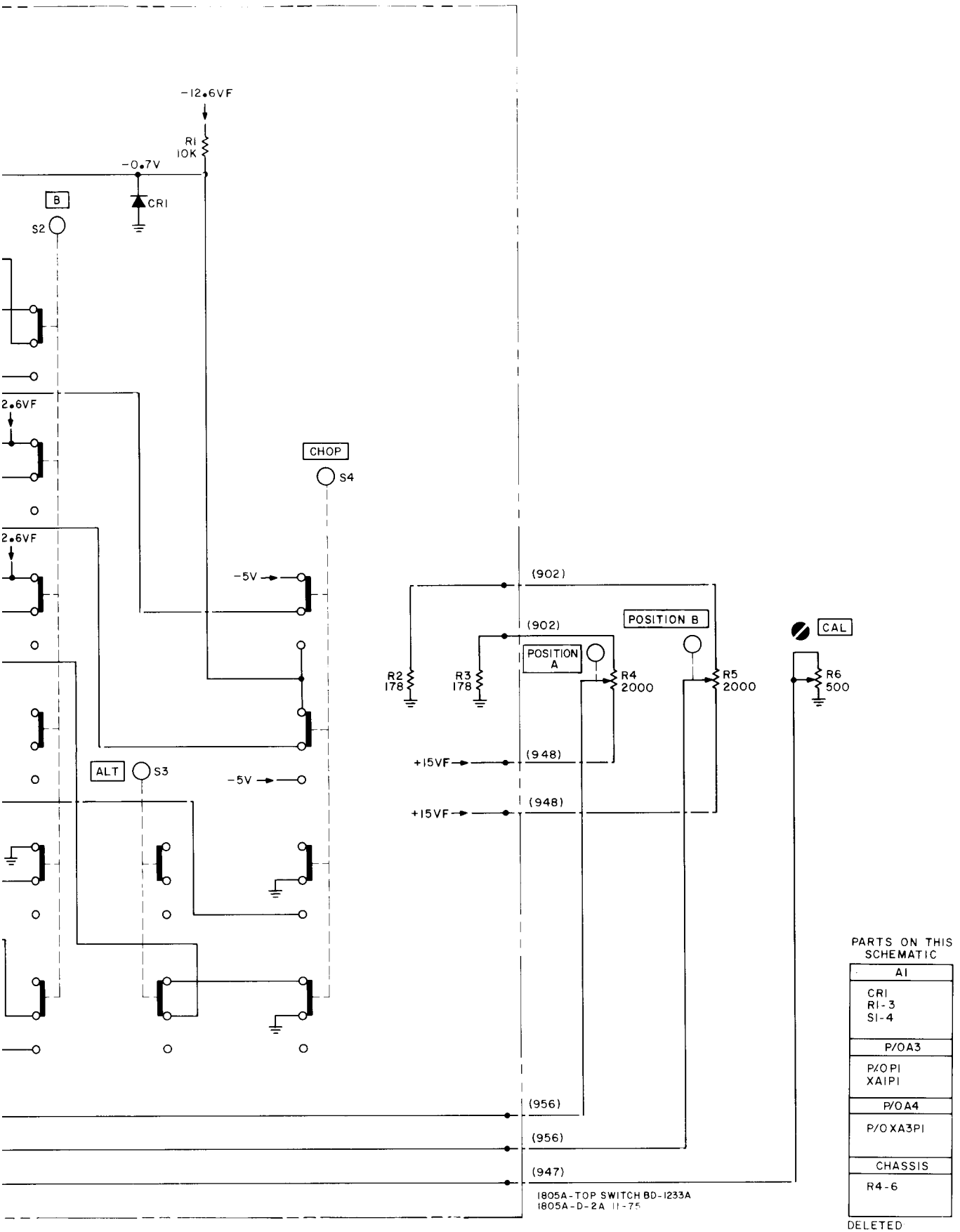

PARTS ON THIS SCHEMATIC

AI
CRI R1-3 S1-4
P/OA3
P/OPI XA1PI
P/OA4
P/OXA3PI
CHASSIS
R4-6
DELETED

5

Figure 8-14.  
Top Switch Board Schematic  
8-17

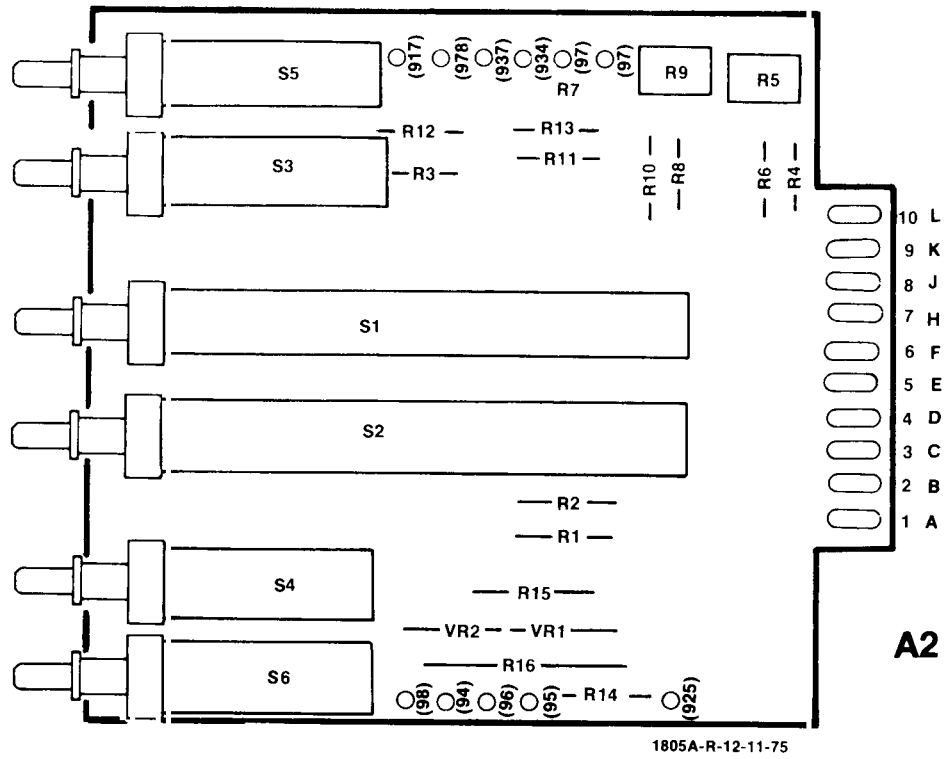

REF DESIG	GRID LOC	REF DESIG	GRID LOC
R1	D-3	R13	D-1
R2	D-3	R14	D-4
R3	C-1	R15	D-4
R4	E-1	R16	D-4
R5	E-1	S1	C-2
R6	E-1	S2	C-3
R7	D-1	S3	C-1
R8	E-1	S4	C-4
R9	E-1	S5	C-1
R10	E-1	S6	C-4
R11	D-1	VR1	D-4
R12	C-1	VR2	D-4

Figure 8-15. Bottom Switch Board A2, Component Identification

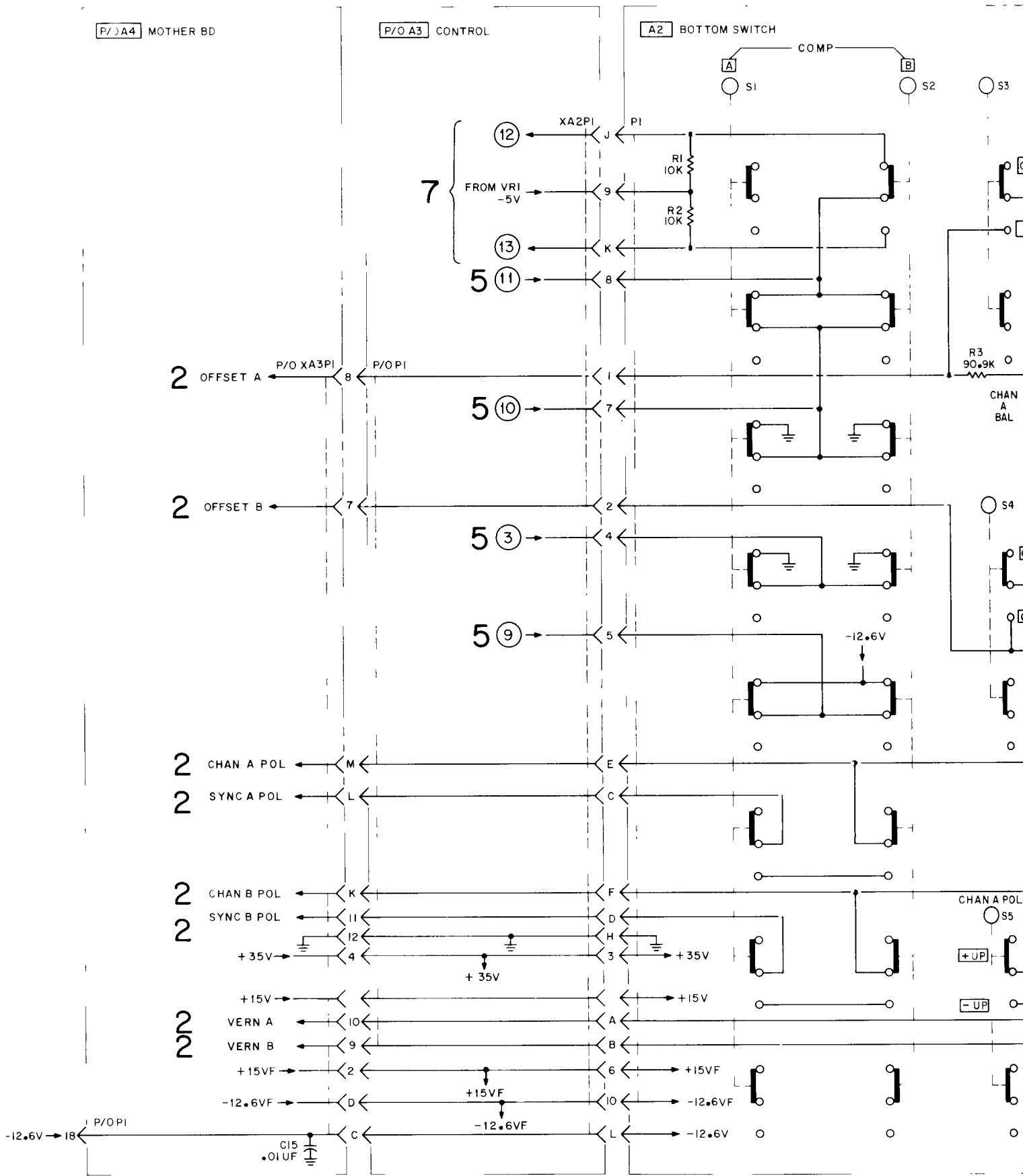

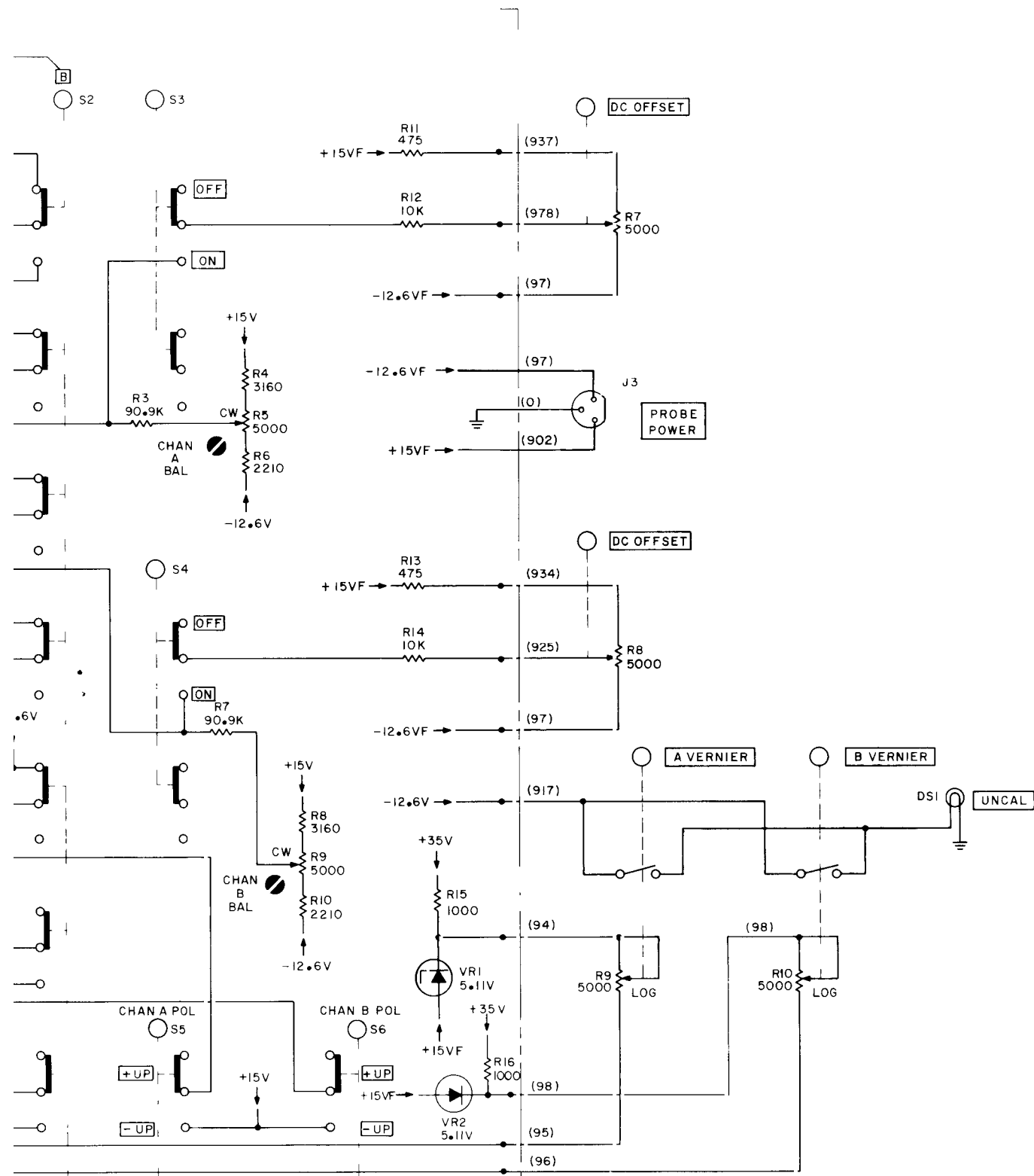

PARTS ON THIS SCHEMATIC

A2	P/O A3	P/O A4	CHASSIS
PI	P/O PI	C15	DS1
RI-16	XA2PI	PI	J3
SI-6		P/O XA3PI	R7-10
VR1, 2			

6

1805A-BOTTOM SWITCH BD-1233A  
1805A-D-3A-11-75

DELETED

Figure 8-16.  
Bottom Switch Board Schematic  
8-19

**VOLTAGE MEASUREMENT CONDITIONS  
SCHEMATIC 7**

**OSCILLOSCOPE**

Focus .....	as necessary
Intensity .....	as necessary
Horizontal position .....	as necessary
Mag .....	X1
Display .....	Internal

**TIME BASE**

Time/division .....	0.5 m/sec
Trigger .....	Internal
Mode .....	Auto

**MODEL 1805A**

DISPLAY .....	A
TRIG SOURCE .....	A
Polarity .....	+ UP
VOLTS/DIV .....	.005
VERNIER .....	CAL
POSITION .....	as necessary
Coupling .....	GND

*Figure 8-18. Control Board Schematic (Sheet 1 of 2)*

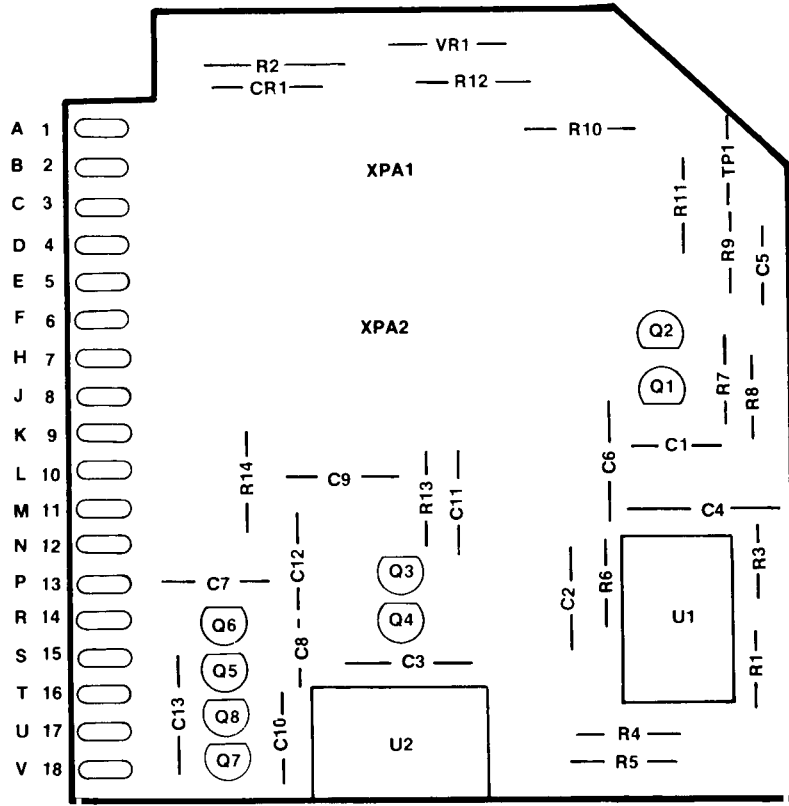

1805A-R-8-11-75

**A3**

REF DESIG	GRID LOC	REF DESIG	GRID LOC	REF DESIG	GRID LOC	REF DESIG	GRID LOC
C1	E-3	C12	C-4	Q8	C-4	R10	D-1
C2	D-4	C13	B-4	R1	E-4	R11	E-2
C3	D-4	CR1	C-1	R2	C-1	R12	D-1
C4	E-3	Q1	E-3	R3	E-4	R13	D-3
C5	E-2	Q2	E-2	R4	E-5	R14	C-3
C6	E-3	Q3	D-4	R5	E-5	U1	E-4
C7	C-4	Q4	D-4	R6	E-4	U2	D-5
C8	C-4	Q5	C-4	R7	E-3	VR1	D-1
C9	C-3	Q6	C-4	R8	E-3	XPA1	C-2
C10	C-4	Q7	C-5	R9	E-2	XPA2	C-2
C11	D-3						

Figure 8-17. Control Board A3, Component Identification

P/OA4

P/OA3 CONTROL

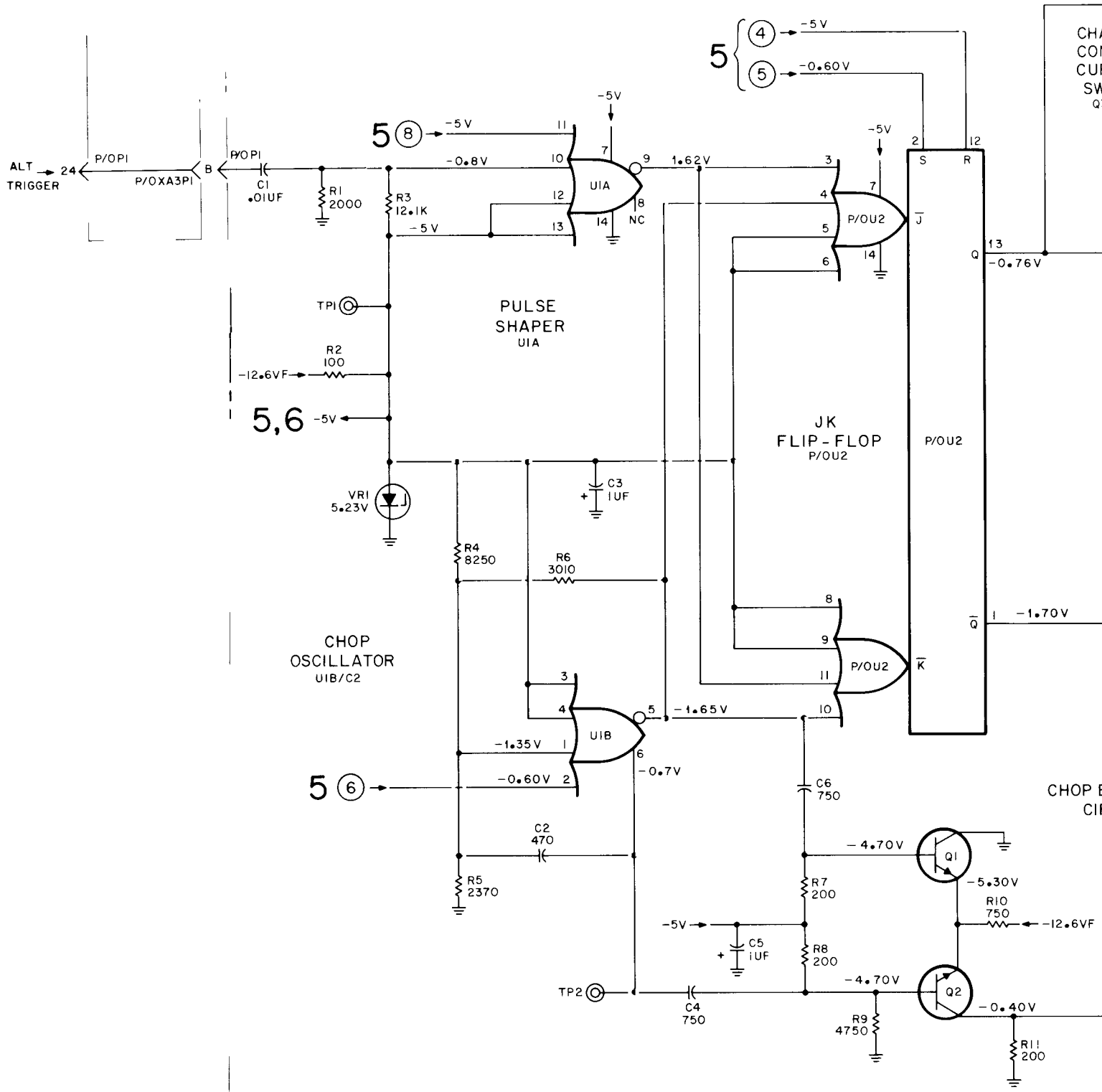



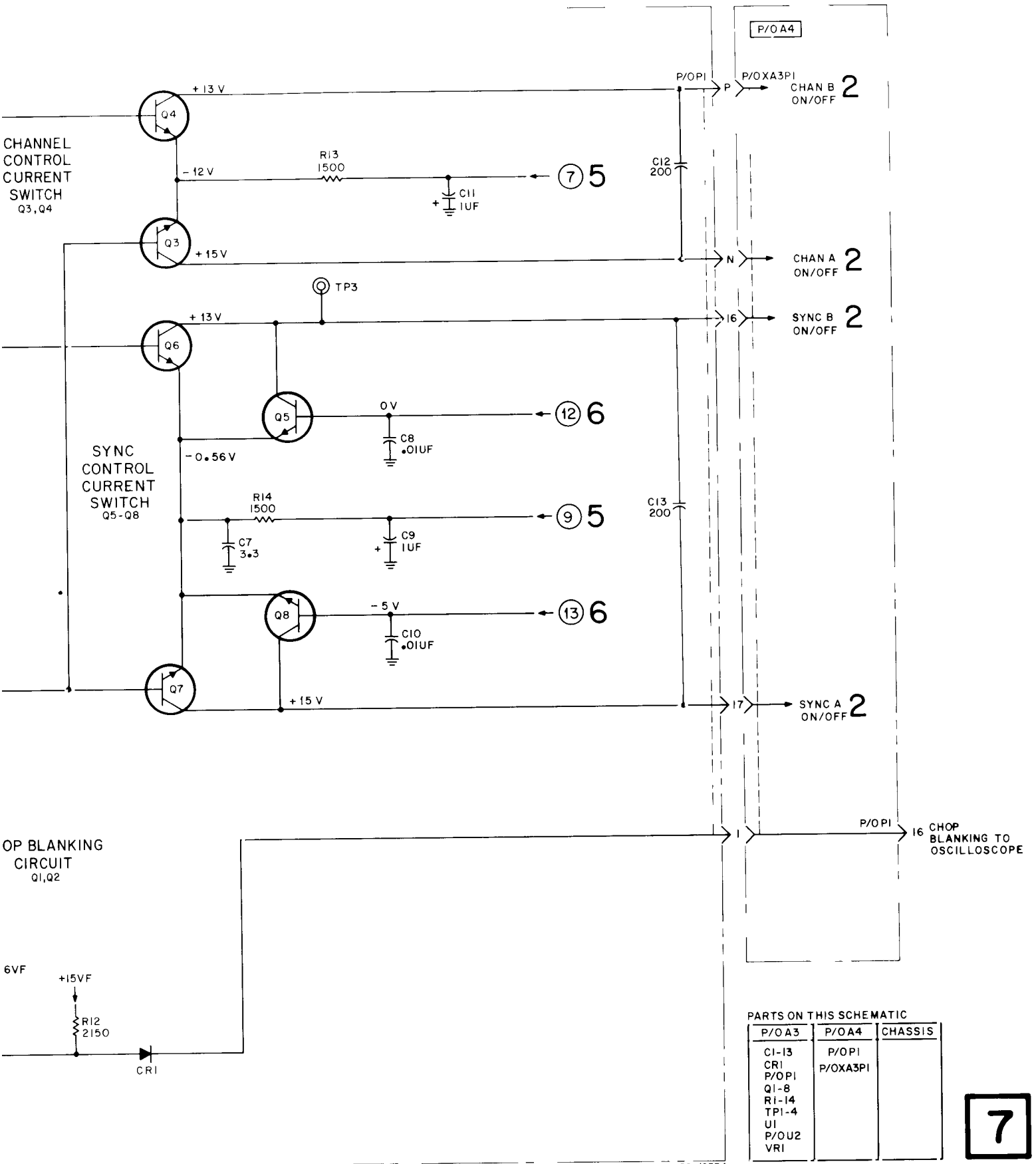

1805A-CONTROL BD-1233A  
1805A-D-4 A -11-75

7

Figure 8-18.  
Control Board Schematic (Sheet 2 of 2)  
8-21

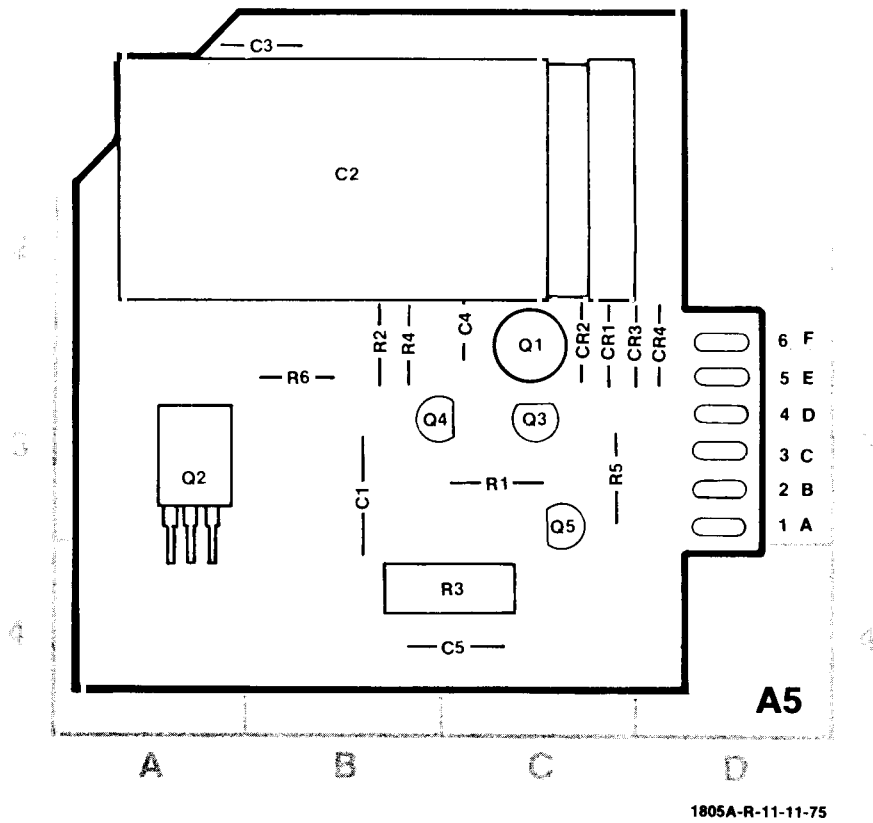

REF DESIG	GRID LOC	REF DESIG	GRID LOC	REF DESIG	GRID LOC	REF DESIG	GRID LOC
C1	B-3	CR1	C-2	Q2	A-3	R2	B-2
C2	B-2	CR2	C-2	Q3	C-3	R3	C-4
C3	B-1	CR3	D-2	Q4	C-4	R4	B-2
C4	C-2	CR4	D-2	Q5	B-3	R5	C-3
C5	C-4	Q1	C-2	R1	C-3	R6	B-3

Figure 8-19. Power Supply Board A5, Component Identification

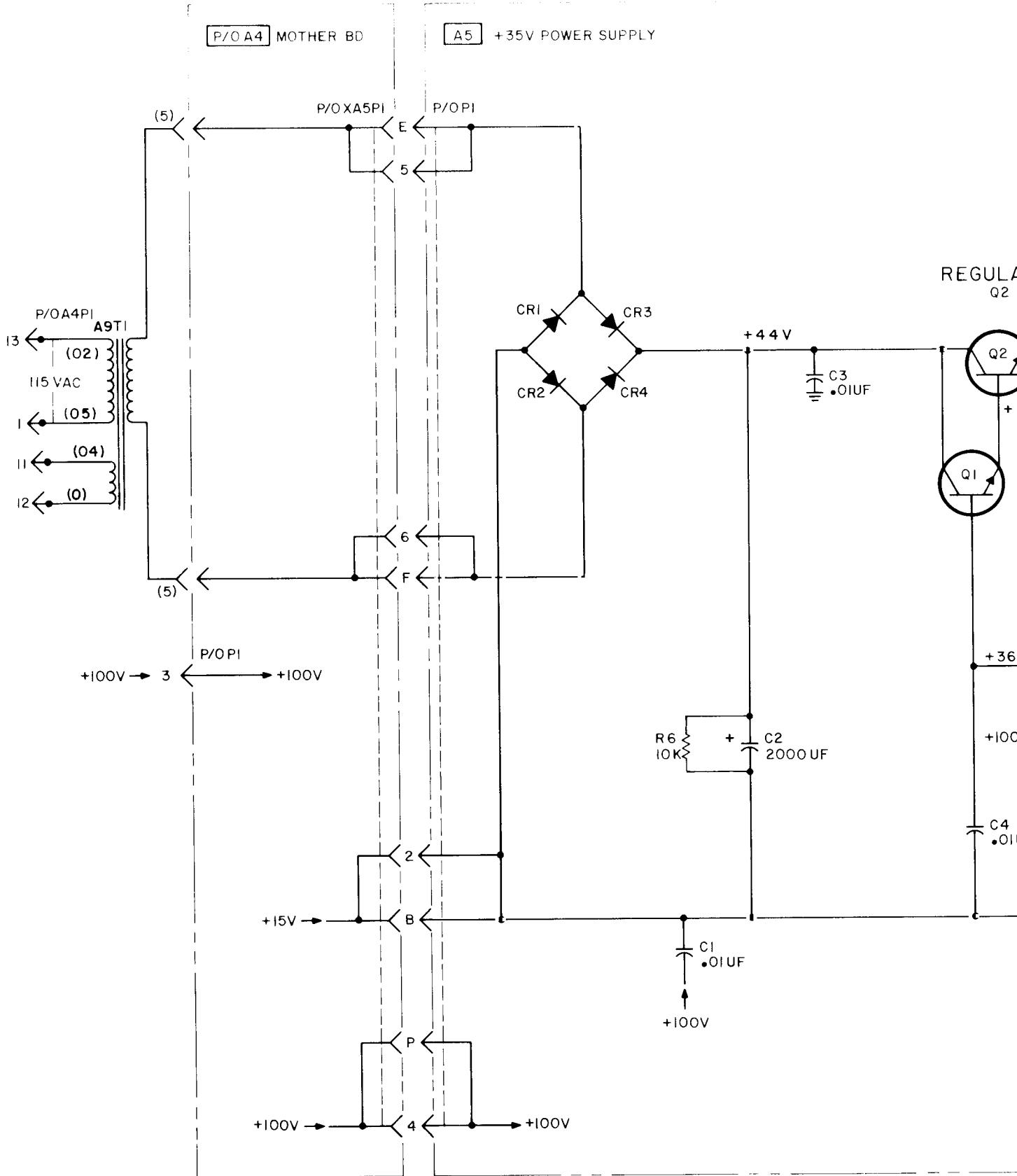

P/O A4 MOTHER BD

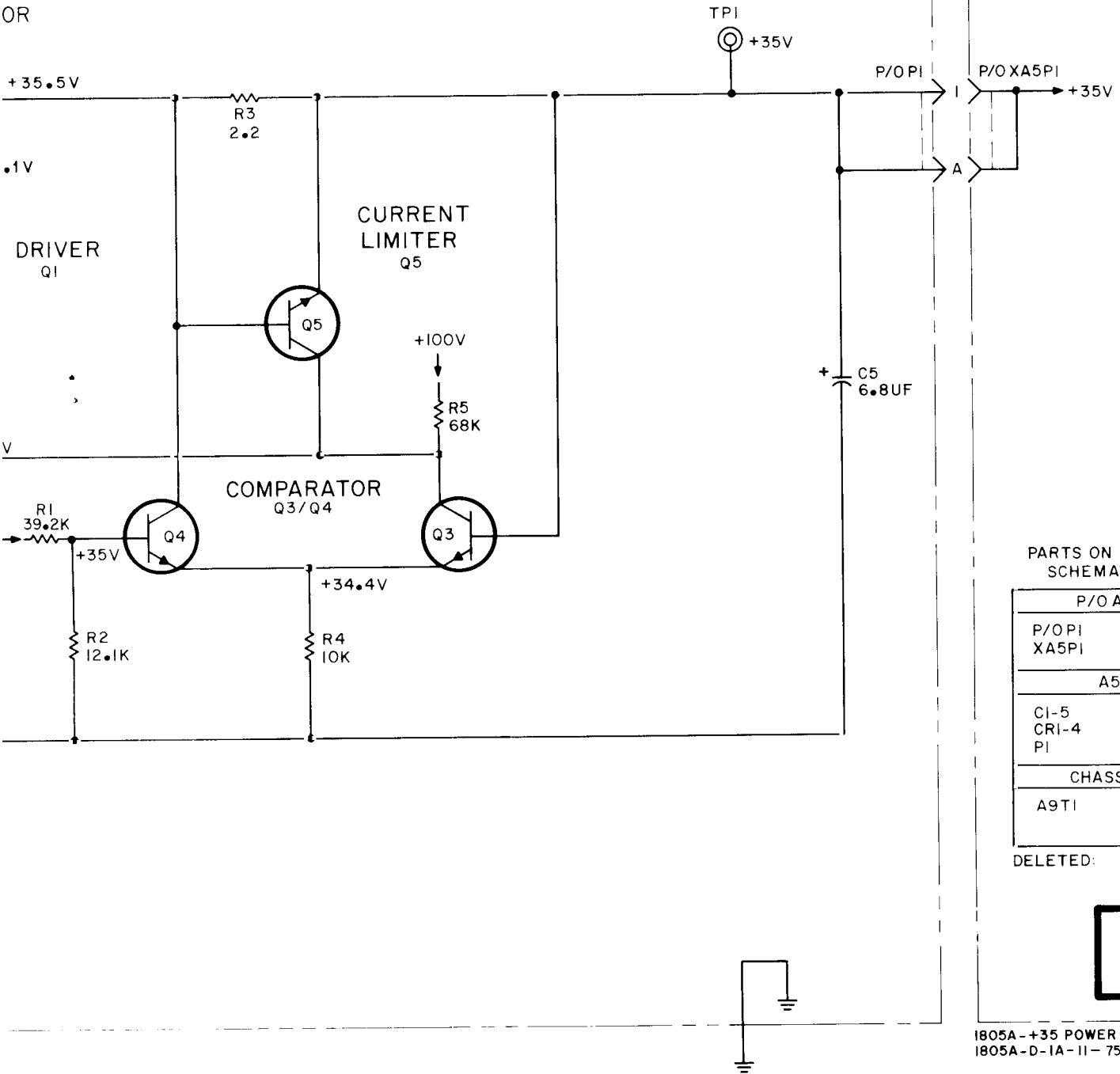

PARTS ON THIS SCHEMATIC

P/O A4	
P/O PI	XA5PI
A5	
CI-5	QI-5
CR1-4	RI-6
PI	TPI
CHASSIS	
A9TI	

DELETED:



1805A-- +35 POWER SUPPLY -12 33A  
1805A-D-1A-II-75

Figure 8-20.  
Power Supply Schematic  
8-23



# **K4XL's** **BAMA**

This manual is provided **FREE OF CHARGE** from the “BoatAnchor Manual Archive” as a service to the Boatanchor community.

It was uploaded by someone who wanted to help you repair and maintain your equipment.

If you paid anyone other than BAMA for this manual, you paid someone who is making a profit from the free labor of others without asking their permission.

You may pass on copies of this manual to anyone who needs it. But do it without charge.

Thousands of files are available without charge from BAMA. Visit us at <http://bama.sbc.edu>