

200AB

AUDIO OSCILLATOR

OPERATING AND SERVICING MANUAL

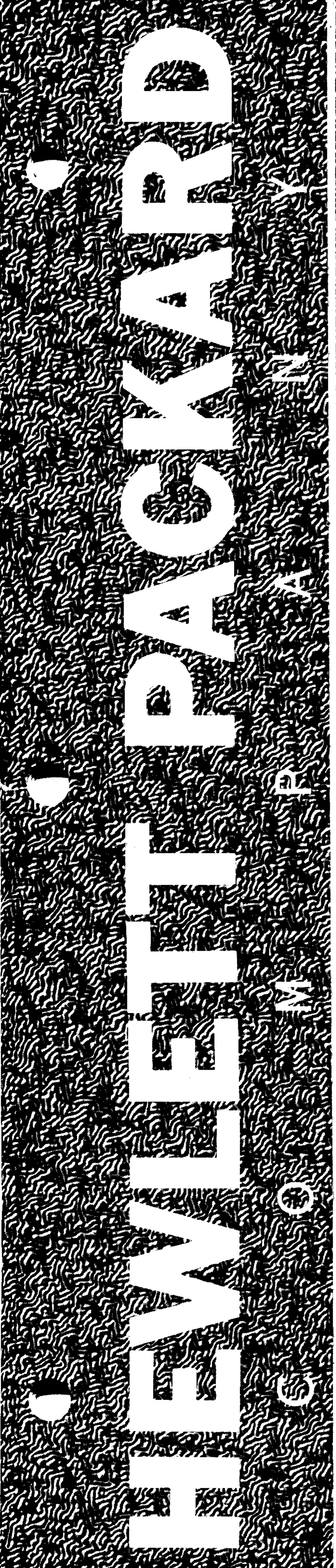

OPERATING AND SERVICING MANUAL



MODEL 200AB/ABR AUDIO OSCILLATOR

SERIAL 7725 AND ABOVE



TABLE OF CONTENTS
FOR
MODEL 200AB AUDIO OSCILLATOR

Section I **GENERAL DESCRIPTION**

		Page
1-1	General	I - 1
1-2	Inspection	I - 1
1-3	Power Source Voltage	I - 1
1-4	Power Cable	I - 1

Section II **OPERATING INSTRUCTIONS**

2-1	Controls and Terminals	II - 1
2-2	Operation of the Instrument	II - 1

Section III **CIRCUIT DESCRIPTION**

3-1	General	III - 1
-----	-------------------	---------

Section IV **MAINTENANCE**

4-1	Removal of Case	IV - 1
4-2	Tube Replacement	IV - 1
4-3	Replacement of Electrolytic Capacitors	IV - 1
4-4	Replacement of Lamp R11	IV - 1
4-5	Lubrication of the Tuning Capacitor Drive Mechanism	IV - 1
4-6	230 Volt Power Transformer Conversion	IV - 1
4-7	Trouble Shooting	IV - 2

Section V **TABLE OF REPLACEABLE PARTS**

5-1	Table of Replaceable Parts	V - 1
-----	--------------------------------------	-------

SPECIFICATIONS

FREQUENCY RANGE:	20 cps to 40 kc.		
BANDS:	X1	20 cps to	200 cps
	X10	200 cps to	2 kc
	X100	2 kc to	20 kc
	X200	4 kc to	40 kc
CALIBRATION ACCURACY:	±2% including calibration error, warm-up, and changes due to aging of tubes and components.		
FREQUENCY DIAL:	Six inch diameter, calibrated over 300° of arc. 72 divisions. Total scale length, 63 inches. Vernier control for precise setting.		
FREQUENCY RESPONSE:	±1 db entire frequency range when working into rated load (reference 1 kc).		
FREQUENCY STABILITY:	Line voltage variations of ±10% cause negligible shift in output frequency.		
POWER OUTPUT:	1 watt or 24.5 volts into a 600 ohm load.		
DISTORTION:	Less than 1%, 20 cps to 20 kc; less than 2%, 20 kc to 40 kc when working into rated load or higher impedance.		
INTERNAL IMPEDANCE:	Approximately 75 ohms from 20 cps to 20 kc. Output is balanced to ground over entire frequency range (may be operated one side grounded, if desired).		
HUM AND NOISE:	At least 66 db below rated output (less than 0.05% of rated output).		
POWER SUPPLY:	115/230 volts, 50/1000 cps, 70 watts.		
DIMENSIONS:	Cabinet: 7-3/8" wide, 11-1/2" high, 12" deep. Rack: 19" wide, 7" high, 11" deep behind panel.		
WEIGHT:	Cabinet: 15 lbs., shipping 20 lbs. Rack: 19 lbs., shipping 30 lbs.		

SECTION I

GENERAL DESCRIPTION

1-1 GENERAL

The Model 200AB Audio Oscillator is designed for general purpose audio testing and measurements. The resistance-capacity oscillator used in this instrument will retain its high degree of accuracy for long periods of time with no adjustment. The push-pull output amplifier used in the Model 200AB has a large amount of overall negative feedback for maximum stability and low distortion. The output impedance of the instrument is 600 ohms balanced or unbalanced. The output voltage is adjustable from 0 to 24.5 volts (1 watt) across a 600 ohm resistive load over the full range of 20 to 40,000 cycles/second, and is sufficient for modulating signal generators or other applications that require considerable power.

1-2 INSPECTION

After the instrument is unpacked, it should be carefully checked for damage received in transit. If any shipping damage is found, follow the procedure outlined in the "Claim for Damage in Shipment" section on the last page of this instruction book.

1-3 POWER SOURCE VOLTAGE

The 200AB, like other instruments, is shipped from the factory with the power transformer dual primary windings connected for operation from a 115 volt a-c source unless otherwise specified on the order. If operation from a 230 volt a-c source is desired, the transformer primary windings can be quickly reconnected. Refer to Section IV, paragraph 4-6 for details.

1-4 POWER CABLE

The three-conductor power cable supplied with this instrument is terminated in a polarized three-prong male connector recommended by the National Electrical Manufacturers' Association. The third contact is an offset round pin added to a standard two-blade connector which grounds the instrument chassis when used with an appropriate receptacle. To use this connector with a standard two-contact receptacle, an adapter should be used to connect the NEMA connector to the two-contact system. When the adapter is used, the third contact is terminated in a short lead from the adapter which can then be connected to a suitable ground.

SECTION II OPERATING INSTRUCTIONS

2-1 CONTROLS AND TERMINALS

ON

This toggle switch controls the power supplied to the instrument from the power line. When the instrument is turned on, a glow will be visible through the plastic frequency dial index.

RANGE

This rotary switch changes resistance values in the frequency determining sections of the instrument. The position of this switch determines the multiplying factor that must be used to convert the frequency dial indication to the actual output frequency of the instrument.

AMPLITUDE

This control is a potentiometer that is used to vary the amount of oscillator voltage that is applied to the amplifier section of the instrument, and thus determines the amplitude of the output voltage.

Frequency Dial

This control varies the capacity in the frequency determining circuits of the instrument, and thus varies the output frequency. This dial is calibrated from 20 to 200 and its indication multiplied by the factor indicated by the RANGE switch will give the actual output frequency of the oscillator. The small knob just below the frequency dial (on the right hand side on the rack model) is a vernier control for this dial.

600 Ω , G

The output voltage of the instrument appears at these terminals. The two right hand binding posts (marked 600 Ω) connect directly to the output transformer of the instrument. This 600 Ω output is balanced to ground. The left hand binding post (marked G) is connected to the chassis of the instrument.

FUSE

The fuseholder, located on the back of the instrument, contains a .8 ampere slow-blowing fuse. For 230 volt operation this fuse should have a .4 ampere rating.

2-2 OPERATION OF THE INSTRUMENT

The procedure for correct operation of the Model 200AB is as follows:

- a. Connect the power cable to a suitable power source.
- b. Turn the power switch on and allow about five minutes for the instrument to reach its normal operating temperature.
- c. Set the Frequency Dial and the RANGE switch for the desired operating frequency. For example: the desired output frequency is 5000 cycles/sec., set the Frequency Dial to 50 and the RANGE switch to X100 (50 x 100 is 5000).
- d. Connect the instrument to the equipment under test. A description of the various types of output available from the instrument follows:
 - 1) 600 ohm balanced or unbalanced output may be obtained as follows:

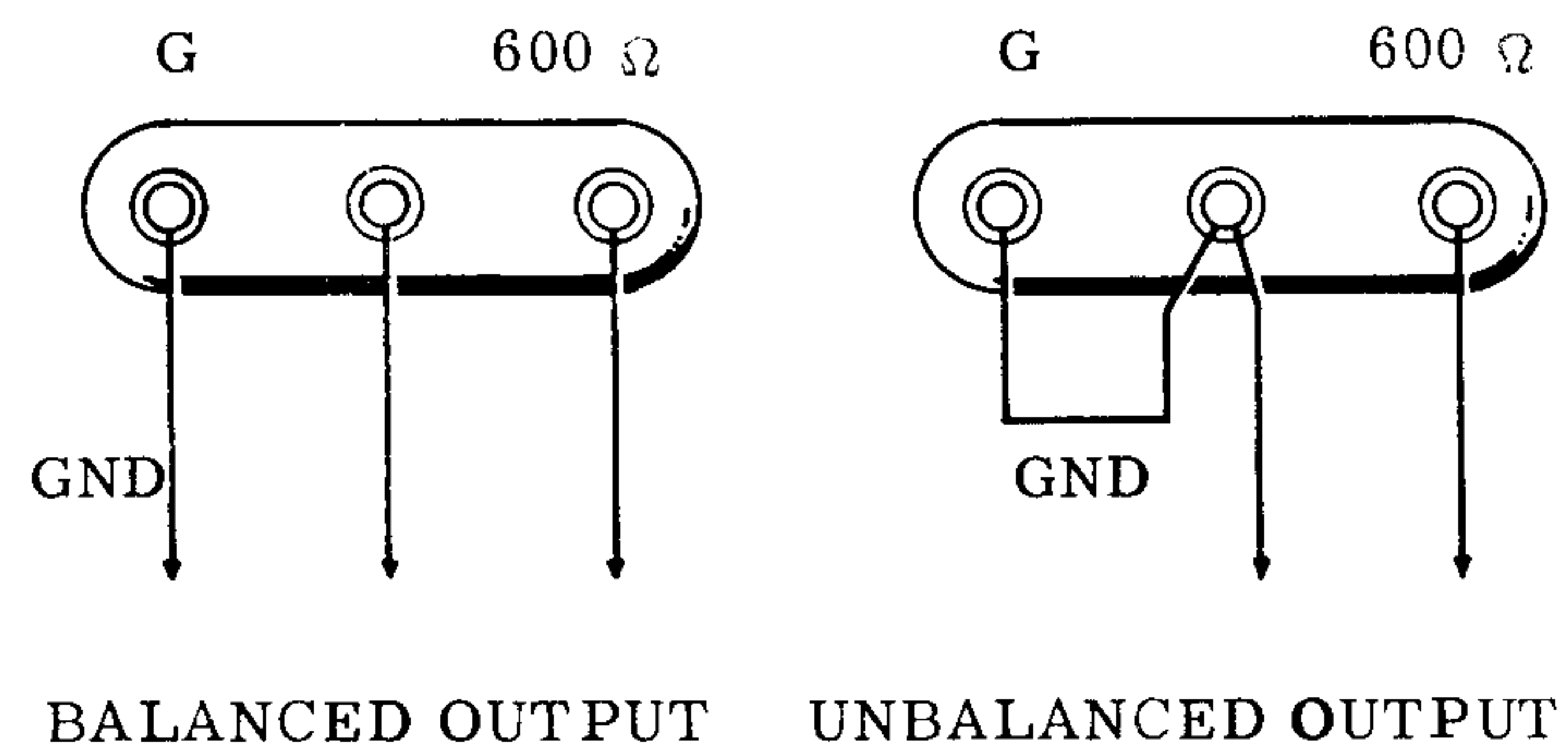

2) If a generator with an internal impedance of 600 ohms is desired, the Model 200AB may be connected as follows:

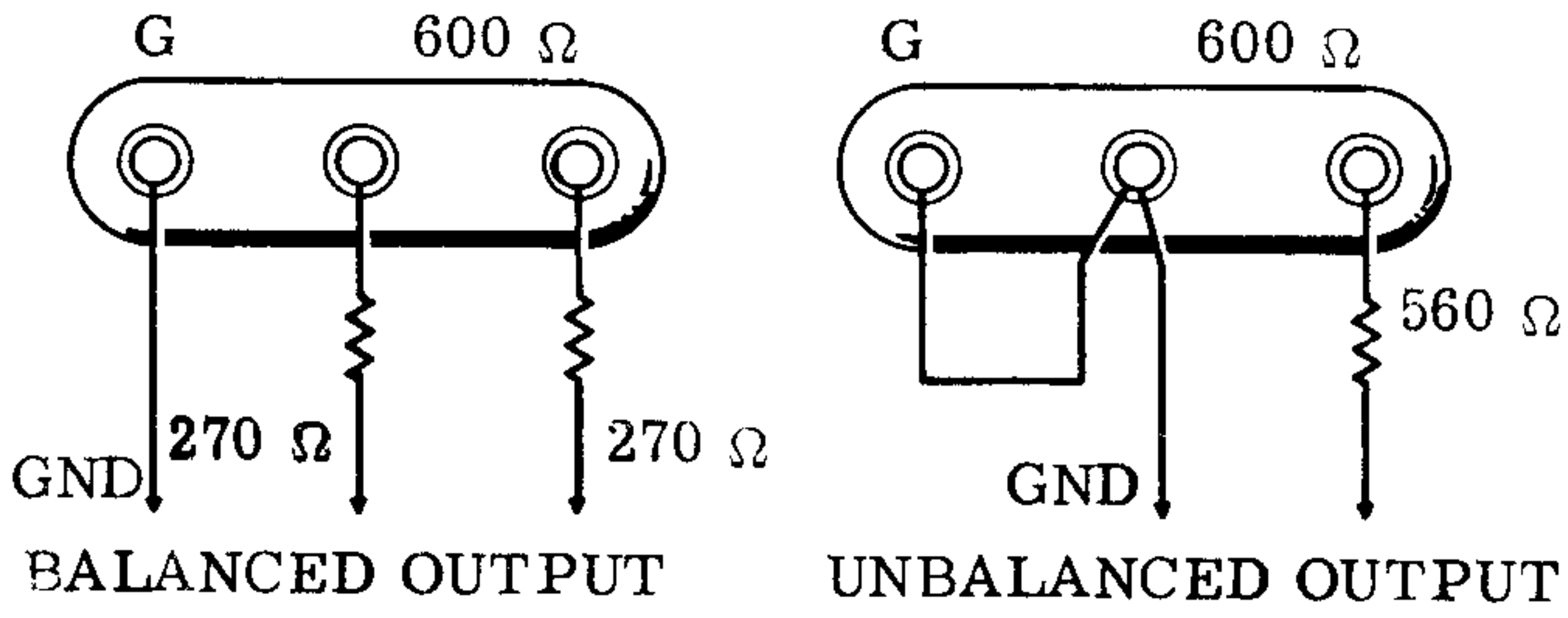

Under these conditions the output voltage available to a 600 ohm load will be reduced to approximately 12 volts and the power will be reduced to approximately 1/4 watt.

CAUTION

To minimize distortion in the output voltage, the instrument should work into a load of 600 to 6000 ohms resistive.

e. Set the **AMPLITUDE** controls so the Model 200AB is delivering the desired voltage to the equipment under test. If a small output voltage with minimum noise is desired, best results will be obtained by externally attenuating the instrument output rather than by decreasing the **AMPLITUDE** control. The

input to the external attenuator should be approximately 20 volts for the best possible signal to noise ratio. The Hewlett-Packard Model 350B Attenuator may be used for this purpose if the instrument is being used to supply an unbalanced signal. A balanced attenuator should be used to attenuate a balanced signal. A simple voltage divider will also be sufficient in many cases, the total resistance of the voltage divider should be approximately 600 ohms.

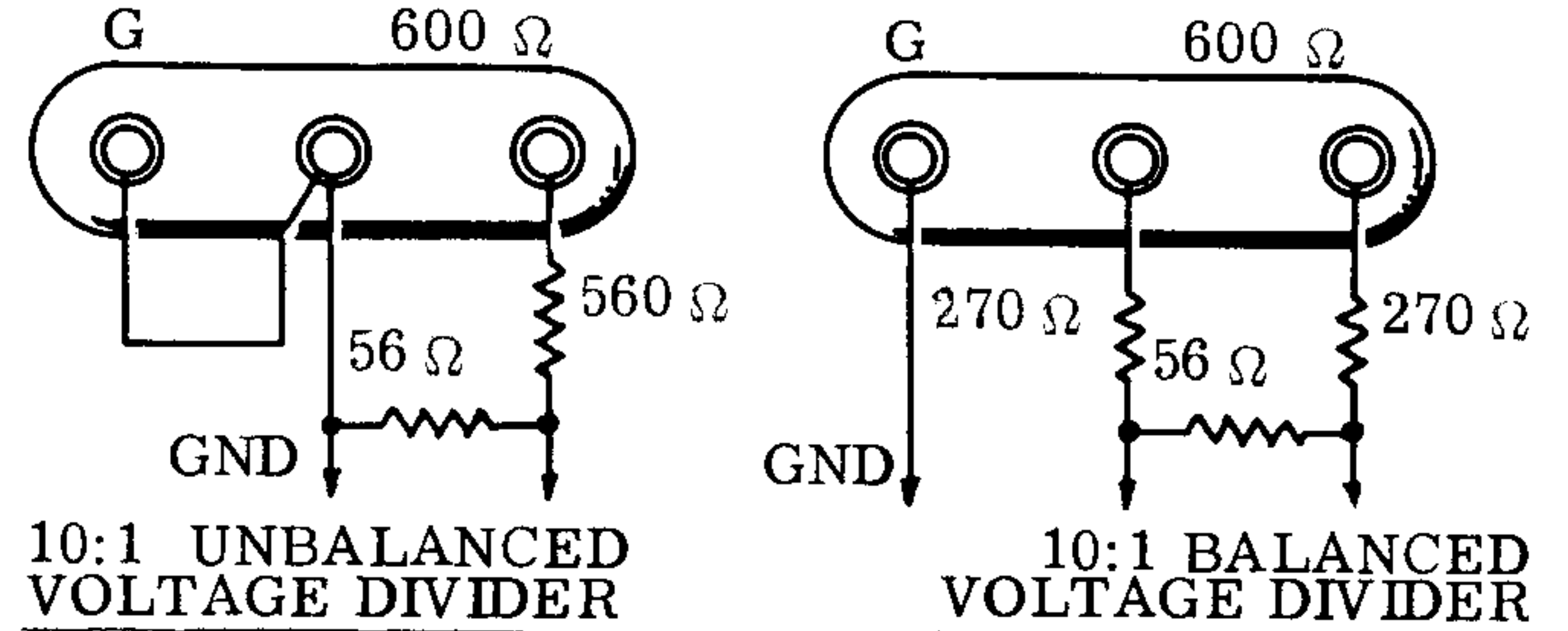

This type of output attenuator is suitable when the output impedance of the instrument is not critical. When a low voltage is desired for testing low impedance circuits, it may be obtained by first attenuating the oscillator output with a 600 ohm attenuator and then changing the impedance by means of a transformer such as the Hewlett-Packard #912-17 or a suitable resistive impedance matching pad. The Hewlett-Packard line matching transformer will provide output impedances of 600, 250, 150, 62.5 or 37.5 ohms from a 600 ohm source.

SECTION III CIRCUIT DESCRIPTION

3-1 GENERAL

The circuit of the Model 200AB consists of an oscillator section, a push-pull amplifier section, and a conventional power supply.

The oscillator section consists of a 6SJ7 (V1) and a 6K6 (V2) and is basically a two stage resistance coupled amplifier. Two feedback loops are used around this amplifier, positive feedback to set up oscillations, a negative feedback to reduce distortion

and keep the amplitude of oscillation constant. The positive feedback network contains fixed resistance values and a variable capacitor (see Figure 3-1) is proportioned such that $R_1 C_1 = R_2 C_2$. The oscillator output voltage is applied to this network and the oscillator input voltage is derived from it. Since the input and output signals of a two stage amplifier are in phase, oscillations will occur when the phase shift between the voltage applied to the network and the voltage at the grid of the first stage is zero. The zero phase shift point is also the point of mini-

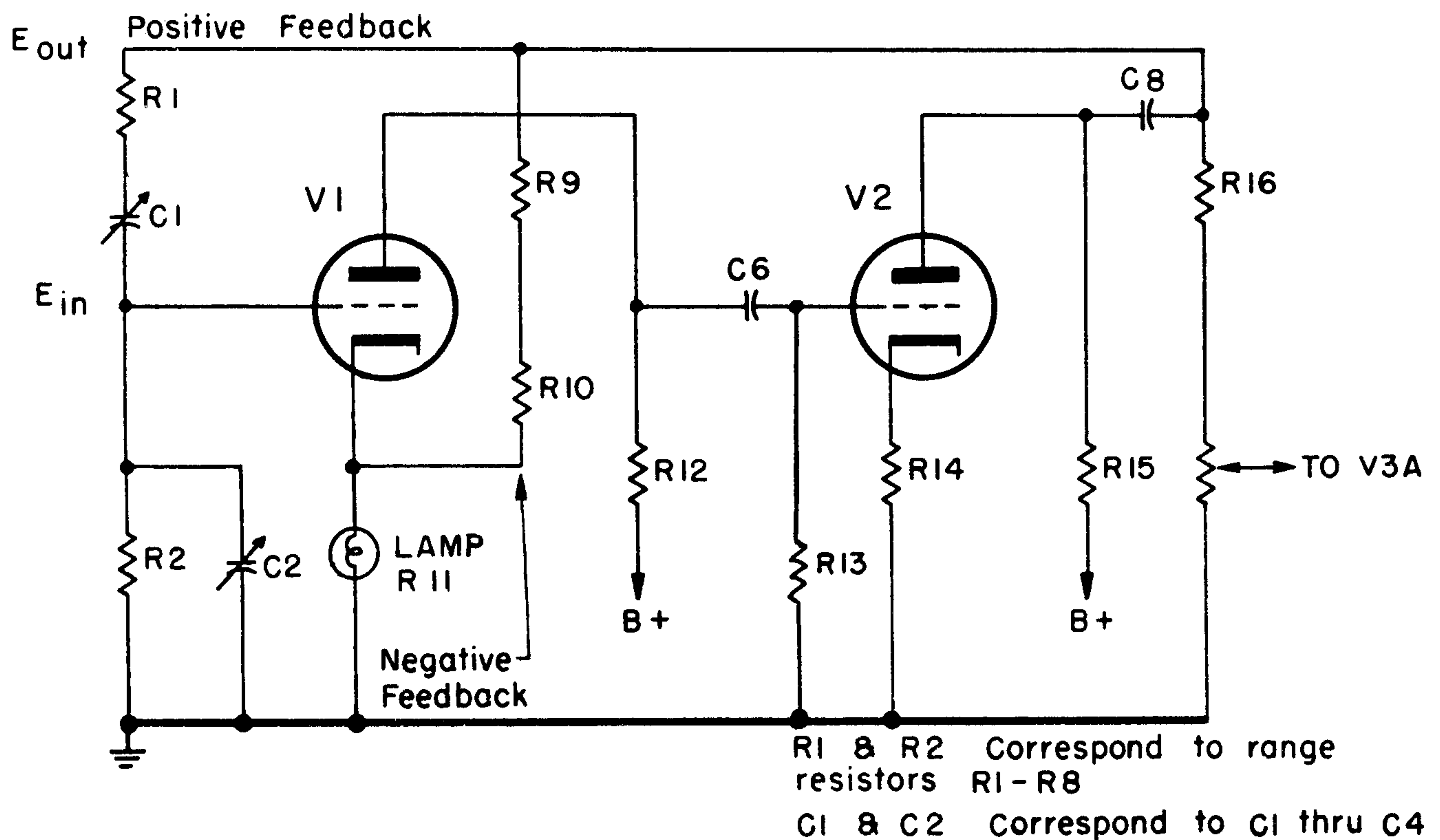

Figure 3-1. Simplified Oscillator Circuit

imum loss through the network as indicated by the curves of Figure 3-2. The frequency of oscillation, $\text{RELATIVE FREQUENCY} = 1$ in Figure 3-1, is equal to $1/2 \pi \sqrt{R_1 C_1 R_2 C_2}$ or $1/2 \pi RC$ since $R_1 = R_2$ and $C_1 = C_2$. The cathode by-pass capacitors in the oscillator section (C5, C7) are to correct phase shift at the higher operating frequencies of the instrument.

The negative feedback network in the oscillator section minimizes changes in oscillator amplitude with changes in frequency. The incandescent lamp is used as a cathode bias resistor, and is also part of the negative feedback voltage divider in the first stage of the oscillator (V1). The lamp has a temperature-resistance characteristic such that its resistance will increase in direct proportion to the voltage applied to it. Changes in the resistance of this lamp will change the percentage of negative feedback in the oscillator circuit. When the oscillator voltage rises, more voltage is applied to the lamp (R11), the increased voltage will raise the temperature and resistance of the lamp which in turn increases the percentage of negative feedback in the oscillator circuit. Increasing the percentage of negative feedback will tend to decrease the oscillator output voltage to its normal operating point. The action will be reversed if the oscillator output voltage decreases, the negative

feedback voltage will decrease lowering the voltage across the lamp (R11) which will lower its resistance thus lowering the percentage of negative feedback and tending to raise the oscillator output to its normal operating point. The thermal inertia of the lamp is great enough so that its resistance will not vary in accordance with the sine wave voltage at the lowest frequencies involved.

The amplifier section of the instrument is a feedback amplifier circuit containing a push-pull output amplifier. The first amplifier tube (V3A) is directly coupled to the phase inverter tube (V3B). The phase inverter drives the output amplifier tubes (V4 and V5). The output transformer contains a tertiary winding for overall negative feedback in the amplifier section. The cathode bias resistor of the first stage (V3A) is not by-passed giving additional negative feedback. This large amount of negative feedback (over 30 db) in the amplifier section results in very little distortion being introduced by the amplifier section of the instrument.

The power supply section of the instrument consists of a conventional full wave rectifier with pi-section filter.

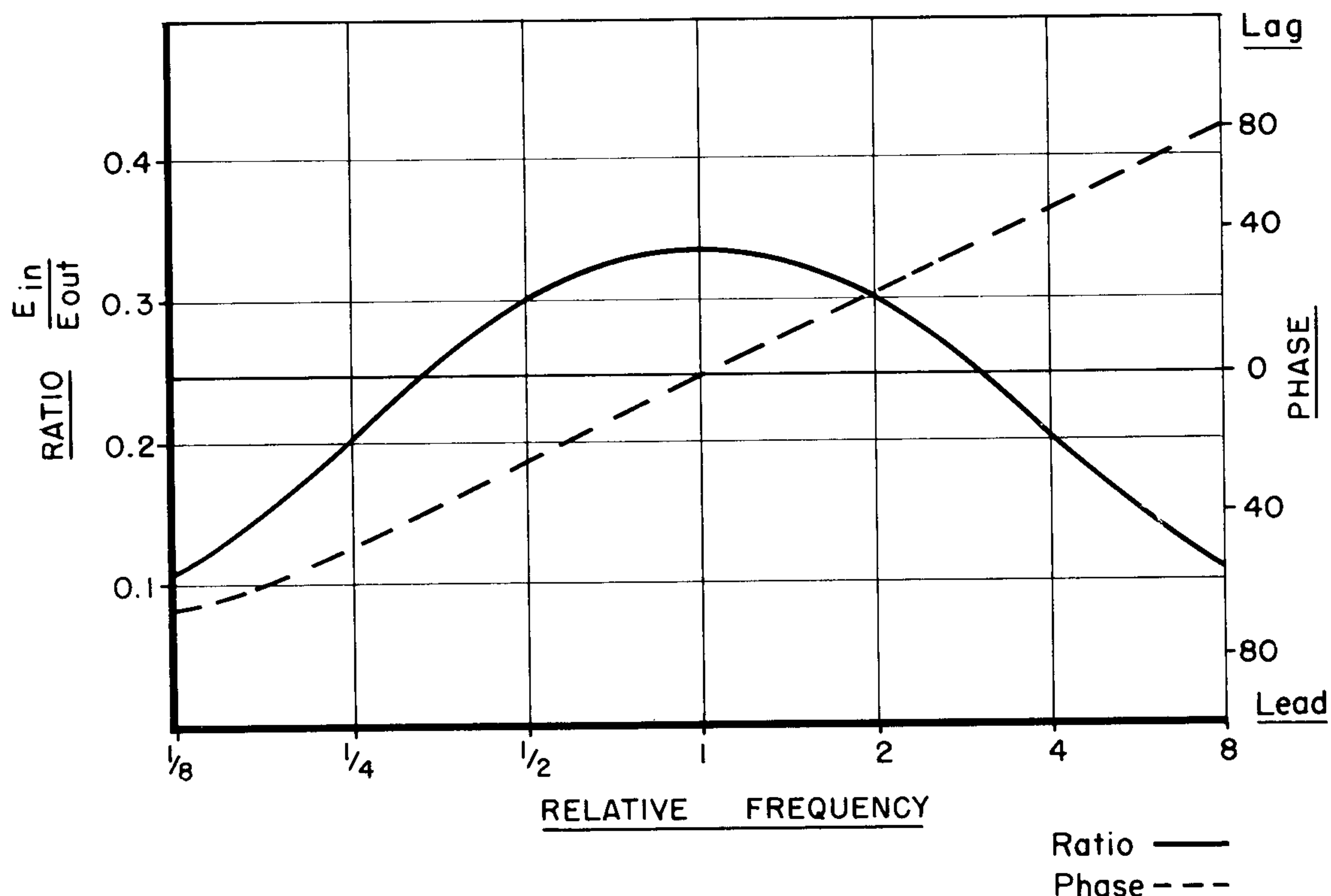

Figure 3-2. Positive Feedback Network Characteristics

SECTION IV MAINTENANCE

CAUTION

The trimmers on the main tuning capacitor (C2 and C4) affect both calibration and frequency response. The settings of these two capacitors should not be changed unless the instrument needs recalibration.

4-1 REMOVAL OF CASE

On the rear cover of the instrument there are two screws that hold the case on the instrument. Removal of these screws will allow the instrument to slide forward out of the case.

4-2 TUBE REPLACEMENT

When replacing any of the tubes, with the exception of the rectifier, distortion measurements should be made to determine whether or not the instrument still meets the specifications set forth in the front of this instruction manual. Poor tubes can greatly increase the noise and distortion components of the output waveform.

4-3 REPLACEMENT OF ELECTROLYTIC CAPACITORS

The electrolytic capacitors in this instrument are very high quality capacitors with a life of from five to ten years.

4-4 REPLACEMENT OF LAMP R11

This lamp operates well below its rating and should have an infinite life. The lamp may be damaged by severe mechanical vibration. If the lamp is damaged, a notch may appear in the output waveform and the

oscillator voltage may be excessive. If the lamp opens, the circuit will not oscillate. If it is necessary to replace the lamp, the oscillator voltage should be checked to make certain it falls within the range specified on the schematic diagram. Measure this voltage between the negative terminal of C8 and chassis (see Figure 4-3 for the location of C8). Adjust the value of R10 until the proper oscillator output is obtained.

4-5 LUBRICATION OF THE TUNING CAPACITOR DRIVE MECHANISM

The tuning capacitor drive mechanism should be lubricated once or twice a year, the interval depending upon the amount of use. One drop of light machine oil in each of the holes in the three bearing projections on the back of the casting is sufficient.

4-6 230 VOLT POWER TRANSFORMER CONVERSION

The 200AB is normally shipped from the factory with the dual 115 volt primary windings of the power transformer connected in parallel for operation from a 115-volt a-c source. The windings can easily be reconnected in series for operation from a 230-volt a-c source if desired. Refer to the schematic drawing and note the transformer primary detail.

To connect T2 for 230-volt operation, remove the jumpers from terminals 2-3 and 4-5. Connect a jumper between terminals 3-4. Replace the 0.8 ampere slow-blow fuse with one rated at 0.4 ampere.

4-7 TROUBLE SHOOTING

The following information is designed to aid in trouble shooting a defective instrument.

TROUBLE SHOOTING CHART

SYMPTOMS	POSSIBLE CAUSE	TEST PROCEDURE	REMEDIES
Instrument NOT operating, pilot light NOT on.	Line fuse blown due to defective fuse or overload in power supply section of instrument.	<p>Replace fuse, if this fuse blows remove V6 (5Y3GT) and again replace the fuse. If this fuse blows it indicates:</p> <ol style="list-style-type: none"> 1. Short circuit in wiring associated with power transformer. 2. Short circuit in filament wiring. 3. Tube with an internal short circuit. 4. Defective power transformer. <p>If fuse does not blow with V6 removed, it indicates:</p> <ol style="list-style-type: none"> 1. Defective filter capacitor C12. DC resistance between pin 8 on V6 socket and ground is normally 50,000 ohms (approximate) and should be measured with the instrument disconnected from the power line. 2. Short in direct current wiring. 	<ol style="list-style-type: none"> 1. Locate and clear short circuit. 2. Locate and clear short circuit. 3. Replace defective tube. 4. Replace power transformer. <ol style="list-style-type: none"> 1. Replace C12 if proven defective. 2. Locate and clear short circuit.
Instrument NOT operating, pilot light ON.	Oscillator section not operating properly.	<p>Measure oscillator voltage between negative terminal of C8 and ground, should agree with the voltage specified on schematic. If oscillator voltage not present, check:</p> <ol style="list-style-type: none"> 1. Defective tube. 2. DC voltage in oscillator circuit (should agree with those indicated on schematic diagram within $\pm 10\%$). 3. Short circuit in tuning capacitor or associated trimmers. Short circuit in front two sections of tuning capacitor will cause lamp (R11) to flash intermittently (lamp filament dull red) when the instrument is set at 1000 cycles/second. 4. Range switch (S1) to make certain it is making good contact and that there are no open range resistors. 	<ol style="list-style-type: none"> 1. Replace V1 and V2. 2. Replace component causing incorrect d-c voltage. 3. Clear short circuit. If trimmer (C2, C3, or C4) is defective replace. If foreign material is shorting tuning capacitor (C1) remove carefully without bending plates. If plates have been damaged and are touching, straighten carefully. 4. Clean range switch contacts or replace assembly if there are any open or damaged resistors.

TROUBLE SHOOTING CHART (CONT'D.)

SYMPTOMS	POSSIBLE CAUSE	TEST PROCEDURE	REMEDIES
	Amplifier section not operating properly, oscillator voltage correct but no output from instrument.	Check dc voltage in amplifier section (V3 thru V5) they should agree with the values indicated on the schematic diagram within $\pm 10\%$. Test amplifier under conditions specified on schematic diagram for voltage measurement (except AMPLITUDE at 60) and with a 600 resistive load on the output terminals.	Replace faulty component in amplifier section.
Instrument operating, high amount of distortion in output voltage	Defective lamp (R11) in oscillator section.	Notch apparent in output waveform as viewed on oscilloscope.	Replace lamp (see paragraph 4-4).
Instrument operating but very small voltage available at output terminals, oscillator voltage normal.	Amplifier section not operating properly.	Check dc voltage in amplifier section. With proper termination on the output, the ac voltage on the grid of V3A should be 13 volts rms and the ac voltage appearing on the grid (pin 5) of V4 or V5 should be 5 volts rms. (These conditions apply for 1 watt output into a 600 Ω load.)	Replace tube or component.
Intermittent operation of instrument.	Defective coupling capacitor C6, C8, C9, C10, C11. Defective tube.	Determine portion of the circuit that is operating intermittently by signal tracing with an oscilloscope or voltmeter.	Replace component causing intermittent operation.
AMPLITUDE control rotation causes unstable output amplitude variation.	AMPLITUDE control (R17) dirty or worn, C9 defective.	<ol style="list-style-type: none"> 1. Check dc voltage on pin 4 of V3, more than .2 volt indicates defective C9. 2. Resistance between arm (center contact) and ground of R17 does not vary smoothly with rotation of AMPLITUDE control. (CAUTION-measure resistance with instrument disconnected from power line.) 	<ol style="list-style-type: none"> 1. Replace C9. 2. Replace R17.

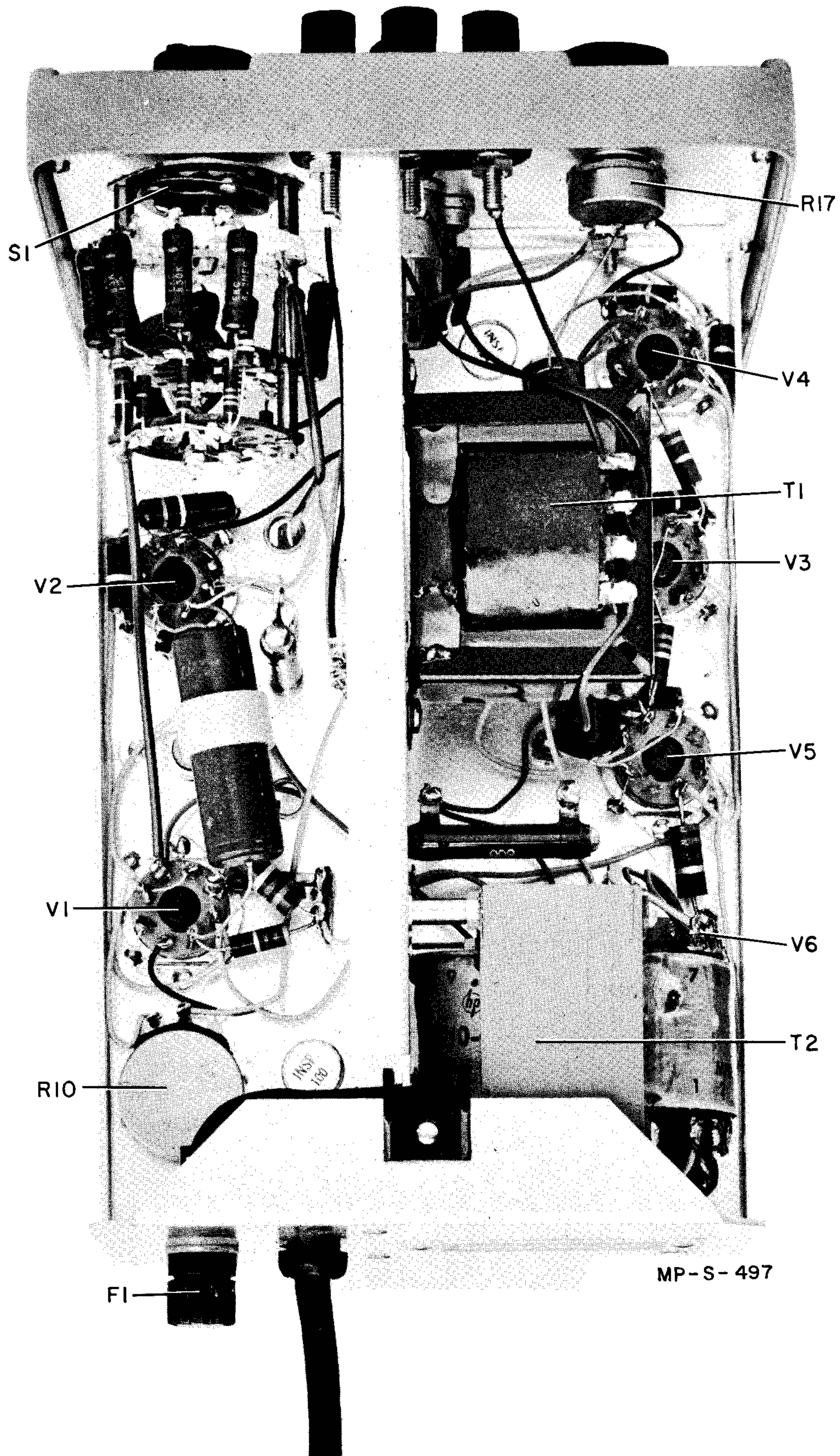

Figure 4-1. Model 200AB Top View

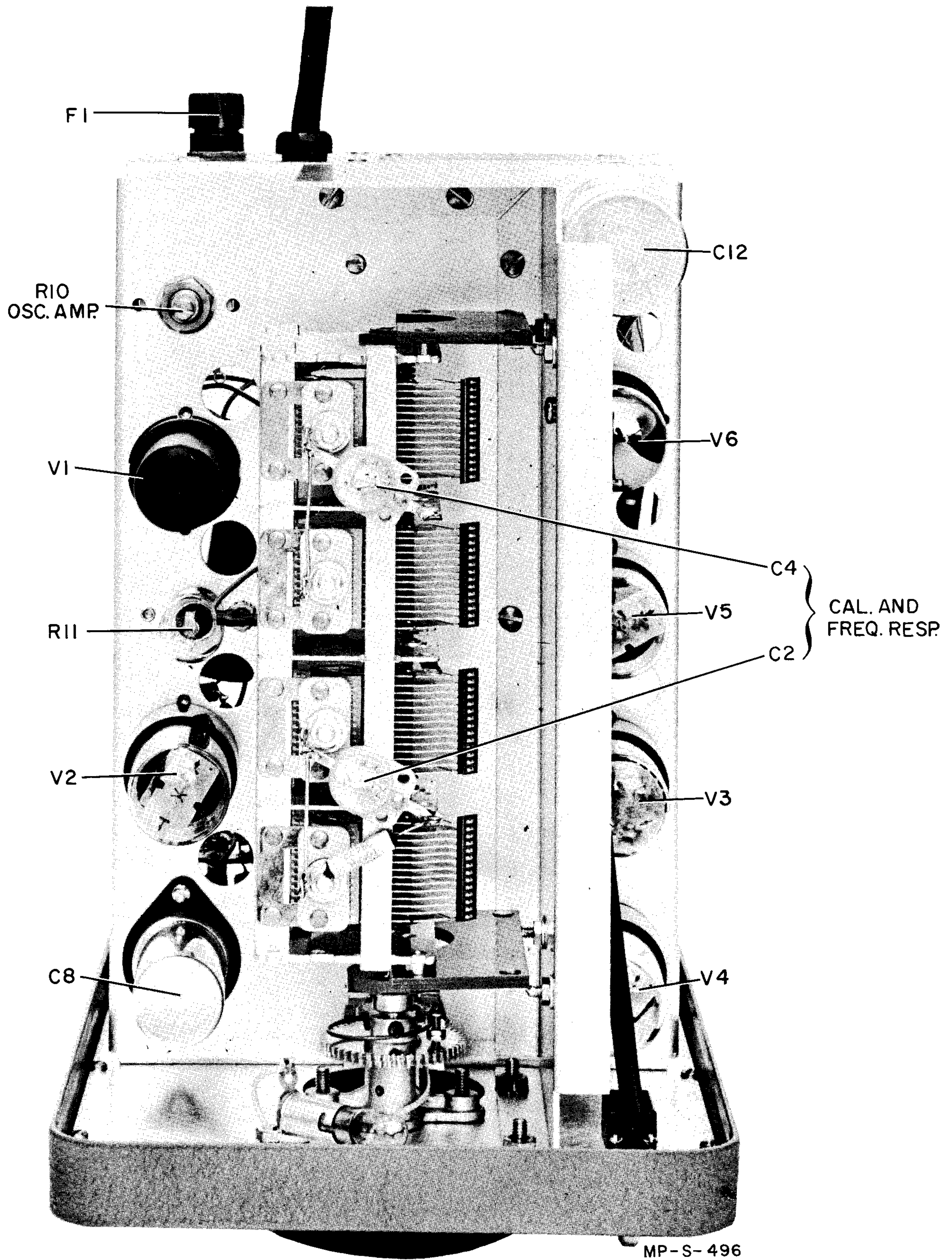

Figure 4-2. Model 200AB Bottom View

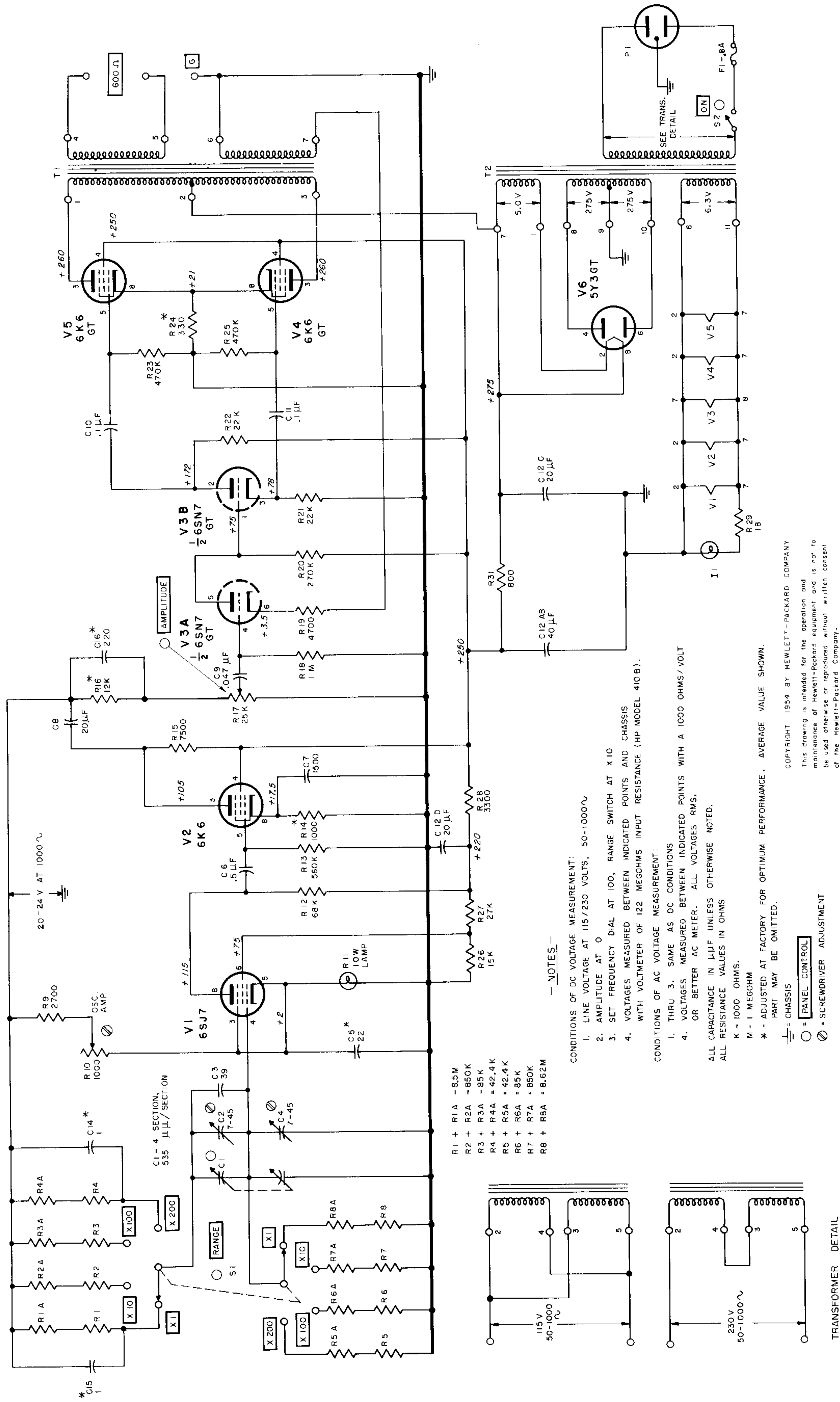

Figure 4-3. Model 200AB Audio Oscillator

SECTION V

TABLE OF REPLACEABLE PARTS

NOTE

Readily available standard-components have been used in this instrument, whenever possible. However, special components may be obtained from your local Hewlett-Packard representative or from the factory.

When ordering parts always include:

1.  Stock Number.
2. Complete description of part including circuit reference.
3. Model number and serial number of instrument.
4. If part is not listed give complete description, function, and location of part.

If there are any corrections for the Table of Replaceable Parts they will be listed on an Instruction Manual Change sheet at the front of this manual.

TABLE OF REPLACEABLE PARTS

CIRCUIT REF.	DESCRIPTION, MFR. * & MFR. DESIGNATION	STOCK NO.	#			
C1	Capacitor: variable, air, 4 sections, 12.4 $\mu\mu\text{f}$ to 535 $\mu\mu\text{f}$ W*	12-7	1			
C2	Capacitor: variable, ceramic, trimmer, 7-45 $\mu\mu\text{f}$, 500 vdcw L*	13-1	2			
C3	Capacitor: fixed, ceramic, 39 $\mu\mu\text{f}$, $\pm 5\%$, 500 vdcw K*	15-4	1			
C4	Same as C2					
C5	Capacitor: fixed, mica, 22 $\mu\mu\text{f}$, $\pm 10\%$, 500 vdcw Z*	14-61	1			
C6	Capacitor: fixed, paper, 0.5 μf , $\pm 10\%$, 400 vdcw J*	16-58	1			
C7	Capacitor: fixed, paper .0015 $\mu\mu\text{f}$, $\pm 10\%$, 600 vdcw CC*	16-32	1			
C8	Capacitor: fixed, electrolytic, 20 μf , 450 vdcw CC*	18-20HP	1			
C9	Capacitor: fixed, paper, .047 μf , $\pm 10\%$, 600 vdcw CC*	16-15	1			
C10, 11	Capacitor: fixed, paper, 0.1 μf , $\pm 10\%$, 600 vdcw CC*	16-1	2			
C12 A, B, C, D	Capacitor: fixed, electrolytic, 4 sections, 20 μf /sect., 450 vdcw CC*	18-42HP	1			
C13	This circuit reference not assigned					
C14, 15	Capacitor: fixed, titanium dioxide, 1.0 $\mu\mu\text{f}$, $\pm 10\%$, 500 vdcw, Electrical value adjusted at factory DD*	15-102	2			
C16	Capacitor: fixed, mica, 220 $\mu\mu\text{f}$, $\pm 10\%$, 500 vdcw, Electrical value adjusted at factory V*	14-220	1			
F1	Fuse, cartridge: 0.8 amp, 115 volt operation T*	211-57	1			
	Fuse, cartridge: 0.4 amp, 230 volt operation T*	211-56				
II	Lamp, incandescent: 6-8V, .15 amp, #47 N*	211-47	1			

* See "List of Manufacturers Code Letters For Replaceable Parts Table".

Total quantity used in the instrument.

TABLE OF REPLACEABLE PARTS

CIRCUIT REF.	DESCRIPTION, MFR. * & MFR. DESIGNATION	STOCK NO.	#			
P1	Power cord Elec. Cords Co.	812-56	1			
R1	Resistor: fixed, deposited carbon, 8.3 megohms, $\pm 1\%$, 1 W part of range switch assembly NN*	31-8.3M	2			
R2	Resistor: fixed, deposited carbon, 830,000 ohms, $\pm 1\%$, 1 W part of range switch assembly NN*	31-830K	2			
R3	Resistor: fixed, deposited carbon, 83,000 ohms, $\pm 1\%$, 1 W part of range switch assembly NN*	31-83K	2			
R4, 5	Resistor: fixed, deposited carbon, 41.5K ohms, $\pm 1\%$, 1 W part of S1 NN*	31-41.5K	2			
R6	Same as R3					
R7	Same as R2					
R8	Same as R1					
R9	Resistor: fixed, composition, 2700 ohms $\pm 10\%$, 1 W R*	24-2700	1			
R10	Resistor: variable, wirewound, 1000 ohms, $\pm 10\%$, 2 W BO*	210-5	1			
R11	Lamp, incandescent: 10 W, 250V N*	211-29	1			
R12	Resistor: fixed, composition, 68,000 ohms, $\pm 10\%$, 1 W B*	24-68K	1			
R13	Resistor: fixed, composition, 560,000 ohms, $\pm 10\%$, 1 W B*	24-560K	1			
R14	Resistor: fixed, composition, 1000 ohms $\pm 10\%$, 2 W Electrical value adjusted at factory B*	25-1000	1			
R15	Resistor: fixed, wirewound, 7500 ohms, $\pm 10\%$, 10 W S*	26-9	1			
R16	Resistor: fixed, composition, 12,000 ohms, $\pm 10\%$, 1 W Electrical value adjusted at factory B*	24-12K	1			

* See "List of Manufacturers Code Letters For Replaceable Parts Table".

Total quantity used in the instrument.

TABLE OF REPLACEABLE PARTS

CIRCUIT REF.	DESCRIPTION, MFR. * & MFR. DESIGNATION	Ⓟ STOCK NO.	#			
R17	Resistor: variable, composition, 25,000 ohms, $\pm 20\%$, 1/3 W BO*	210-11	1			
R18	Resistor: fixed, composition, 1 megohm, $\pm 10\%$, 1 W B*	24-1M	1			
R19	Resistor: fixed, composition, 4700 ohms, $\pm 10\%$, 1 W B*	24-4700	1			
R20	Resistor: fixed, composition, 270,000 ohms, $\pm 10\%$, 1 W B*	24-270K	1			
R21, 22	Resistor: fixed, composition, 22,000 ohms, $\pm 5\%$, 1 W B*	24-22K-5	2			
R23	Resistor: fixed, composition, 470,000 ohms, $\pm 10\%$, 1 W B*	24-470K	2			
R24	Resistor: fixed, composition, 330 ohms, $\pm 10\%$, 2 W Electrical value adjusted at factory B*	25-330	1			
R25	Same as R23					
R26	Resistor: fixed, composition, 15,000 ohms, $\pm 10\%$, 1 W Electrical value adjusted at factory B*	24-15K	1			
R27	Resistor: fixed, composition, 27,000 ohms, $\pm 10\%$, 2 W B*	25-27K	1			
R28	Resistor: fixed, composition, 3300 ohms, $\pm 10\%$, 1 W B*	24-3.3K	1			
R29	Resistor: fixed, composition, 18 ohms, $\pm 10\%$, 1 W B*	24-18	1			
R30	This circuit reference not assigned					
R31	Resistor: fixed, wirewound, 800 ohms, $\pm 10\%$, 10 W S*	26-6	1			
S1	Range Switch Assembly HP*	200AB- 19W	1			
S2	Switch, toggle: SPST D*	310-11	1			

* See "List of Manufacturers Code Letters For Replaceable Parts Table".

Total quantity used in the instrument.

TABLE OF REPLACEABLE PARTS

CIRCUIT REF.	DESCRIPTION, MFR. * & MFR. DESIGNATION	STOCK NO.	#			
T1	Transformer, output Paeco	912-32	1			
T2	Transformer, power Paeco	910-80	1			
V1	Tube, electron: 6SJ7 ZZ*	212-6SJ7	1			
V2	Tube, electron: 6K6GT RCA	212-6K6GT	3			
V3	Tube, electron: 6SN7 ZZ*	212-6SN7	1			
V4, 5	Same as V2					
V6	Tube, electron: 5Y3GT ZZ*	212-5Y3GT	1			
MISCELLANEOUS						
	Binding Post Assembly: red HP*	AC-10D	2			
	Binding Post Assembly: black with ground link HP*	G-76J	1			
	Coupler, insulated HP*	AC-32A	1			
	Disc, vernier drive: on shaft HP*	G-14A	1			
	Disc, vernier drive HP*	G-14B	1			
	Fuseholder T*	140-16	1			
	Handle, cabinet Specialty Leather Co.	144-5	1			
	Holder, lamp: candelabra (used for R11) AD*	145-15	1			
	Holder, lamp AD*	145-13	1			
	Insulator, binding post: 3 hole, black HP*	AC-54B	1			
	Insulator, standoff: 3/4" long AI*	34-34	1			
	Knob: AMPLITUDE HP*	G-74K	1			
	Knob: RANGE HP*	G-74N	1			
	Spring, gear: tuning capacitor gear HP*	624A-36B-5	1			
	Spring, compression: for vernier drive Connor Spring Co.	146-23	1			
	Window, Dial: for curved frequency dial HP*	G-99K	1			

* See "List of Manufacturers Code Letters For Replaceable Parts Table".

Total quantity used in the instrument.



MANUAL CHANGES

MODEL 200AB
AUDIO OSCILLATOR

ERRATA:

- C16: Change to capacitor, fixed, mica, 220uuf $\pm 5\%$, 500 vdcw; -hp- Stock No. 15-32, Mfr., Z
- V6: Change to tube, electron, 5AR4 or 5Y3GT; -hp- Stock No. 212-5AR4, Mfr., ZZ
- P1: Change to power cord; -hp- Stock No. 812-106, Mfr., Elec. Cord Co.