

HEWLETT-PACKARD JOURNAL



COUNTS LO

COUNTS MID
IN PROCESS

COUNTS HI

101

IMPULSE RESPONSE THRESHOLD
 PHASE THRESHOLD
 GAIN THRESHOLD

TRANSMITTER CONTROLS
 FREQUENCY CONTROL
 STEP RATE
 STEP VOLT
 NONLINEAR DISTORTION
 CHECK SIGNAL

LINE MONITOR
 OUTPUT
 SIGNAL

RECEIVER TUNING JACKS
 NORMAL TEST
 TELL BATTERY OFF

MEASUREMENT
 LEVEL, WINDS NOISE
 INTO & DROPOUTS
 IN PROCESS
 DROPOUTS

MEASUREMENT
 LEVEL, WINDS NOISE
 INTO & DROPOUTS
 GAIN HITS

12

PHASE HITS

IN PROCESS

DROPOUTS

GAIN HITS

Measuring Analog Parameters of Voiceband Data Channels

A new Transmission Impairment Measuring Set combines the measurement capabilities of six separate instruments into one portable package. It measures fifteen parameters affecting data transmission in one-fourth the time formerly required.

by Noel E. Damon

THE PROLIFERATION OF DATA SYSTEMS in all areas of science, business, education, and government has resulted in an explosive demand for new communications capabilities. Because the demand has outpaced the building of specialized data communications networks, most data communications now takes place over channels optimized for voice transmission—the voiceband telephone lines. This vast network has been pressed into a service for which it was not originally designed, for which new parameters are important, and for which new measurement instrumentation is required.

Fig. 1 shows a general data network and the interfaces at which test instruments are used. Notice that both analog and digital testing are done: tests between interfaces A and D are digital, while those between B and C are analog.

Several Hewlett-Packard instruments have been developed to test telephone channels. The choice of one or another of these depends on several factors:

- analog or digital interface
- Bell System standard or CCITT standard
- kind of data service and type of facility
- price/performance tradeoffs.

In the United States and Canada, Bell System standards prevail, while CCITT standards are used in most other countries. These standards define different parameters, measurement techniques, and measurement units, so different instruments are required.

For digital tests, the Hewlett-Packard test set for telephone channels with modems is Model 1645A Bit Error Rate Analyzer.¹ For higher-speed digital channels Model 3760A/61A Data Generator/Error Detector² may be used.

Analog Channels

Analog channels may contain cable and microwave links, including satellite relays and various types of carrier systems. Three classes of tests are performed

on the analog channels: installation, routine maintenance, and troubleshooting. Sixteen parameters are commonly used in characterizing an analog data channel, their individual significance depending on signaling speed. The table below lists these parameters and the model numbers of the Hewlett-Packard instruments that measure them according to Bell System and CCITT standards.



Cover: Model 4940A Transmission Impairment Measuring Set is the first instrument capable of separating and simultaneously measuring six types of transient events in voice channels: dropouts, gain hits, phase hits, and three levels of impulse noise. It displays the results three counts at a time. The 4940A also measures eleven other parameters important to data transmission.

In this Issue:

Measuring Analog Parameters of Voiceband Data Channels, by Noel E. Damon **page 2**
Transient Measurements, by Paul G. Winninghoff, **page 8**. *The 4940A Sine Wave Transmitter*, by Richard T. Lee, **page 9**. *Nonlinear Distortion Measurements*, by Donald A. Dresch, **page 12**. *Envelope Delay Distortion Measurements*, by Richard G. Fowles and Johann J. Heinzl, **page 14**. *Peak-to-Average Ratio Measurements*, by Erhard Ketelsen, **page 17**. *Microwave Integrated Circuits Solve a Transmission Problem in Educational TV*, by James A. Hall, Douglas J. Mellor, Richard D. Pering, and Arthur Fong **page 20**

Parameter	CCITT		Bell Standard			
	3552A	3770A	3551A	4940A	5453A/ 5468A	3581C
Loss	•	•	•	•	•	•
Amplitude Distortion	•	•	•	•	•	•
Message Circuit Noise	•		•	•	•	
Noise-to-Ground	•		•	•	•	
Noise with Tone	•		•	•	•	
Phase Distortion (Envelope Delay)		•		•	•	
Impulse Noise				•	•	
Echo						
Single-Frequency Interference	•		•	•	1	1
Frequency Shift				•	•	
Phase Jitter				•	•	
Nonlinear Distortion				•	•	
Phase Hits				•	•	
Gain Hits				•	•	
Dropouts				•	•	
Peak-to-Average Ratio				•	•	

1 Uses a spectral analysis technique

Instruments:

- 3552A Transmission Test Set
- 3770A Amplitude/Delay Distortion Analyzer
- 3551A Transmission Test Set
- 4940A Transmission Impairment Measuring Set
- 5453A Fourier Analyzer with 5468A Transponder
- 3581C Selective Voltmeter

Why so many instruments? First of all, if the service is for low speed, DDD (direct distance dialing) and the facility is known to be entirely copper wire to the nearest central office, then not all of the measurements are really necessary. In North America, the 3551A Transmission Test Set may provide the complete testing answer. However, for higher-speed data, private lines, or carrier-routed service, complete testing of more parameters is necessary. Therefore, one of the more elaborate instruments with this complete capability is required, either Model 4940A Transmission Impairment Measuring Set or Model 5453A/5468A Fourier Analyzer/Transponder. Choosing between these two requires a price/performance decision.

The Fourier analyzer system is a computerized testing and record-keeping system. It allows testing of a

line in less than two minutes with no operator intervention. The basic system with a minimum number of transponders costs over \$60,000. Such a system can replace multiple manual analog test sets and can be more economical on a per-set-of-equipment basis for large installations—10 units or greater.

The 4940A Transmission Impairment Measuring Set is a greatly improved manual test instrument. It requires operator interaction and separate recording and filing of test results, and takes about ten minutes to make all of the tests the Fourier analyzer makes, plus transient analysis. It is fully compatible with most existing test equipment and costs on the order of \$8,000, depending on options.

Transmission Impairment Measuring Set (TIMS)

Some of the instruments listed in the table above will be described in detail in forthcoming issues of the Hewlett-Packard Journal. This article describes the new Model 4940A Transmission Impairment Measuring Set (Fig. 2), which is designed to measure analog parameters that affect data transmission in United States and Canada telephone channels. It is used at the interfaces designated B and C in Fig. 1. Parameters measured by the 4940A are:

- Loss
- Amplitude distortion (relative or absolute loss as a function of frequency)
- Dropouts (sudden large decreases in channel gain)
- Gain hits (sudden positive or negative gain changes exceeding a preselected threshold)
- Phase hits (sudden shifts of channel phase exceeding a preselected threshold)
- Impulse noise exceeding three preselected thresholds
- Weighted noise (3-kHz flat weighted or C-message weighted)
- Noise with tone (weighted noise in the presence of a 1004-Hz tone)

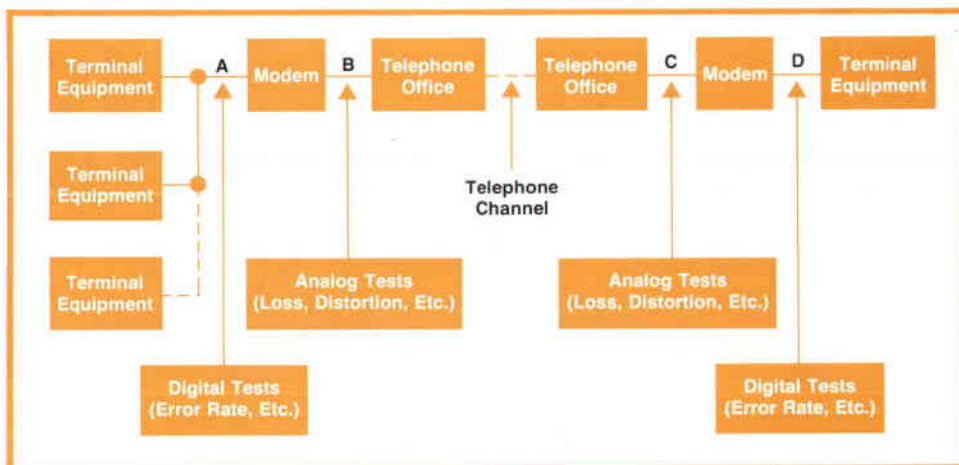

Fig. 1. A general data network, showing where analog and digital test instruments are used.

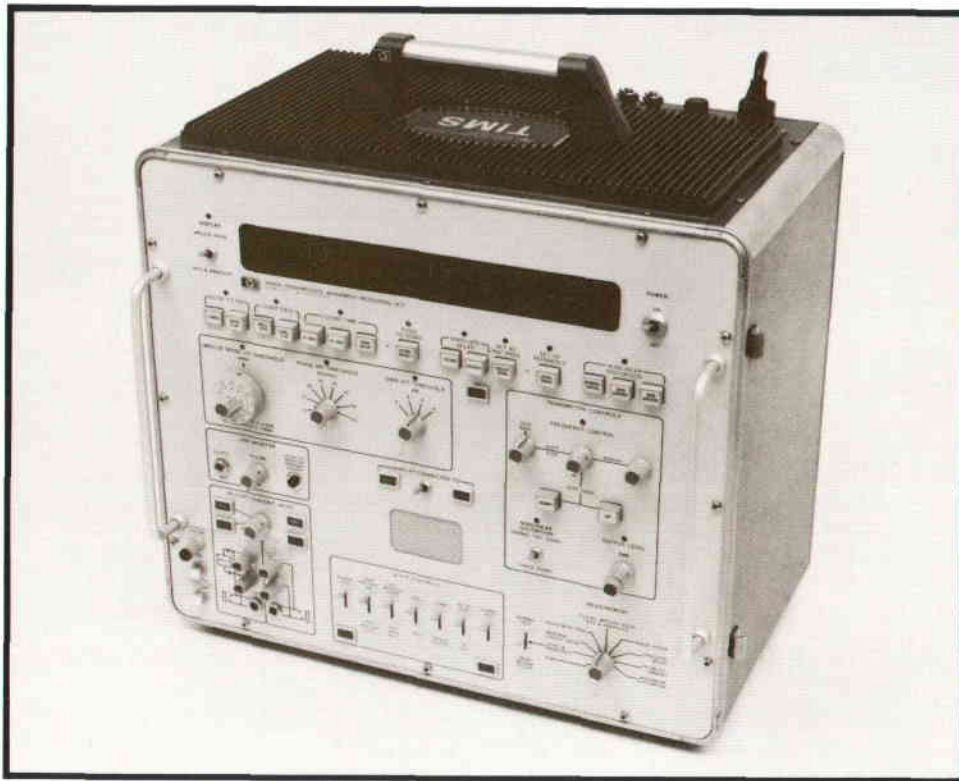

Fig. 2. Model 4940A Transmission Impairment Measuring Set measures fifteen analog parameters affecting data transmission in one-fourth the time formerly required. Tests are according to Bell System standards used in North America.

- Phase noise or jitter of 300-Hz bandwidth
- Relative envelope delay as a function of frequency
- Frequency shift
- Longitudinal noise or noise line-to-ground
- Single-frequency interference
- Intermodulation or nonlinear distortion
- Peak-to-average ratio (P/AR)

The last two are optional.

All measurement functions are provided in the 4940A on balanced lines of either 600 or 900 ohms impedance. Measurements are made in a full-duplex mode on two-pair channels or half-duplex on single-pair channels. A bridging input is also provided to allow parallel connection with other instruments. Measurements may be made in a loop-around configuration using a single 4940A, or in either direction with a second 4940A or any other instrument capable of measuring individual parameters at the other end of the channel.

The front panel has been organized to minimize the number of controls and make the instrument easy to use. All measurements are autoranging to eliminate range switches. Controls are grouped into fields and inactive displays are blanked. Each control and switch field has associated with it a light-emitting-diode dot light that is illuminated in any measurement in which the control is active. If a switch field is misprogrammed for a particular measurement, all displays and dot lights extinguish except the dot light on that field. When the proper switch setting is made

all displays and lights return to normal. Thus the operator's attention is focused on only those controls requiring selection. Switches and controls not part of a given measurement are disabled to prevent inadvertent interaction.

System Organization

Organization of the 4940A is illustrated by Fig. 3. The 4940A system consists of three transmitters, a receiver with varying filter and detector combinations, analog-to-digital conversion capability, three digital processors, and three digital display fields that may be switched to monitor either receive or transmit functions. A group of annunciators associated with each display field indicates the correct units for that field, depending on the measurement being made.

To reduce power dissipation, a high-efficiency inverter-type switching-regulated power supply³ is used. As a bonus, the conventional power transformer is eliminated.

To facilitate circuit sharing, all measurements are reduced to three parameters: dc level, time interval, and event accumulation.

Input Circuits

There are two transformer-coupled balanced connection ports, one for the transmit pair and one for the receive pair. A switch is provided for interchanging the ports without disconnecting the pairs.

A current source across one input port provides a

current to hold the line relay in dial-up line testing. A connection point is provided for a handset to permit voice communication over the lines being tested using either internal power or line battery. An internal loudspeaker and power amplifier are provided for voice communications and for listening to the line signal. A passive RF-suppression input filter removes signals above 10 kHz without affecting dynamic range or introducing intermodulation distortion. The DISPLAY CONNECTED TO switch determines whether a receive or transmit pair is to be monitored by the measuring circuits and display.

An array of input filters selects the fraction of the voiceband to be measured. There is a 1004-Hz bandpass filter for phase jitter measurements, a 1010-Hz notch filter for noise-with-tone measurements, a 60-Hz high-pass filter that may be used in level/frequency measurements where power-line interference is dominant, a P/AR signal bandpass filter, and notch filters to remove baseband nonlinear distortion signals. Filter functions, transmitted signal type, and detector type are selected by the MEASUREMENT switch.

Autorange and Detection

A programmable autorange amplifier centers all input signals within a fixed 12-dB operating range by inserting up to 110 dB of gain in 10-dB increments. The number of 10-dB gain steps needed to place the signal within the fixed 12-dB operating range provides the tens-digit signal level information. Units and tenths-digit level information is obtained from a digital logarithmic converter that has a 30-dB dynamic range roughly centered on the 12-dB operating region. The response of the autorange amplifier may be shaped by 3-kHz flat, C-message weighting, or second and third-order nonlinear distortion filters, depending on the position of the measurement selection switch.

An appropriate detector selected by measurement type follows the autorange block. An averaging detector is used in sinusoidal level measurements because of its noise rejection abilities and in envelope delay measurements because of its insensitivity to modulation. Peak detectors are used as threshold sensors in impulse noise measurements. A weighted sum of the responses of the peak and average detectors provides an excellent approximation to rms response for noise and nonlinear distortion measurements.

Digital Processor

Digital level information from the logarithmic converter and pulse representations of impulse noise and gain hits are routed to a digital processor. A memory in the processor accumulates and stores the information for subsequent display. An arithmetic unit provides the capability of making relative level/frequency measurements by storing an initial measure-

ment and subtracting this count from all following measurements. When a reference is set, the units annunciator automatically shifts from dBm to dB.

The relative level capability is also used in the nonlinear distortion measurement. Four frequencies in two bands are transmitted. The total signal level is first used to set a reference level. Next, second and third-order intermodulation products are selected by switching in the proper bandpass filters and the relative level of these products is measured directly in dB with respect to the total original signal.

The arithmetic unit averages ten readings of 0.01-dB resolution for each refresh cycle. The refresh rate of the digital display has been chosen so the viewer can see the time variations of the average signal. The overall effect closely simulates the response that would be observed on a meter-type display, but provides 0.1-dB resolution, much better than a meter. Measurement of non-sinusoidal signals is made to 1-dB resolution by averaging 10 or 20 readings of 0.1-dB resolution and rounding the result.

Tracking Filter

A limiter and phase-locked loop form a tracking filter that provides a stable, clean signal from which frequency information is derived. To allow rapid reading of frequency with one-hertz resolution, the digital processor averages ten periods and then computes the signal frequency. The display refresh rate is sufficiently rapid to yield apparently instantaneous response to variation of the front-panel transmitter frequency control. The frequency measurement range is from 200 Hz to above 4 kHz.

The processor also handles accumulation of signal dropouts or impulse noise counts. To detect dropouts (a decrease in absolute carrier level of 12 dB lasting longer than 10 ms), a level reference loop samples the carrier at the beginning of the measurement interval and stores this level as a reference in an absolute reference memory. This level attenuated by 12 dB becomes the reference in a threshold comparator and timing circuit.

A presettable relative threshold detector continuously compares the current absolute peak value of the signal to the same signal value delayed by four milliseconds. If the threshold is exceeded the event is counted as a gain transient or hit.

A limiter, phase-locked loop and 300-Hz bandpass filter compare the absolute value of the phase variation of the received signal in a presettable threshold detector with the same signal delayed by four milliseconds. Exceeding this threshold counts as a phase transient or hit.

In the measurement of phase noise or jitter the error signal from the phase-locked loop is detected peak-to-peak at the 2.58-sigma level, quantized by an

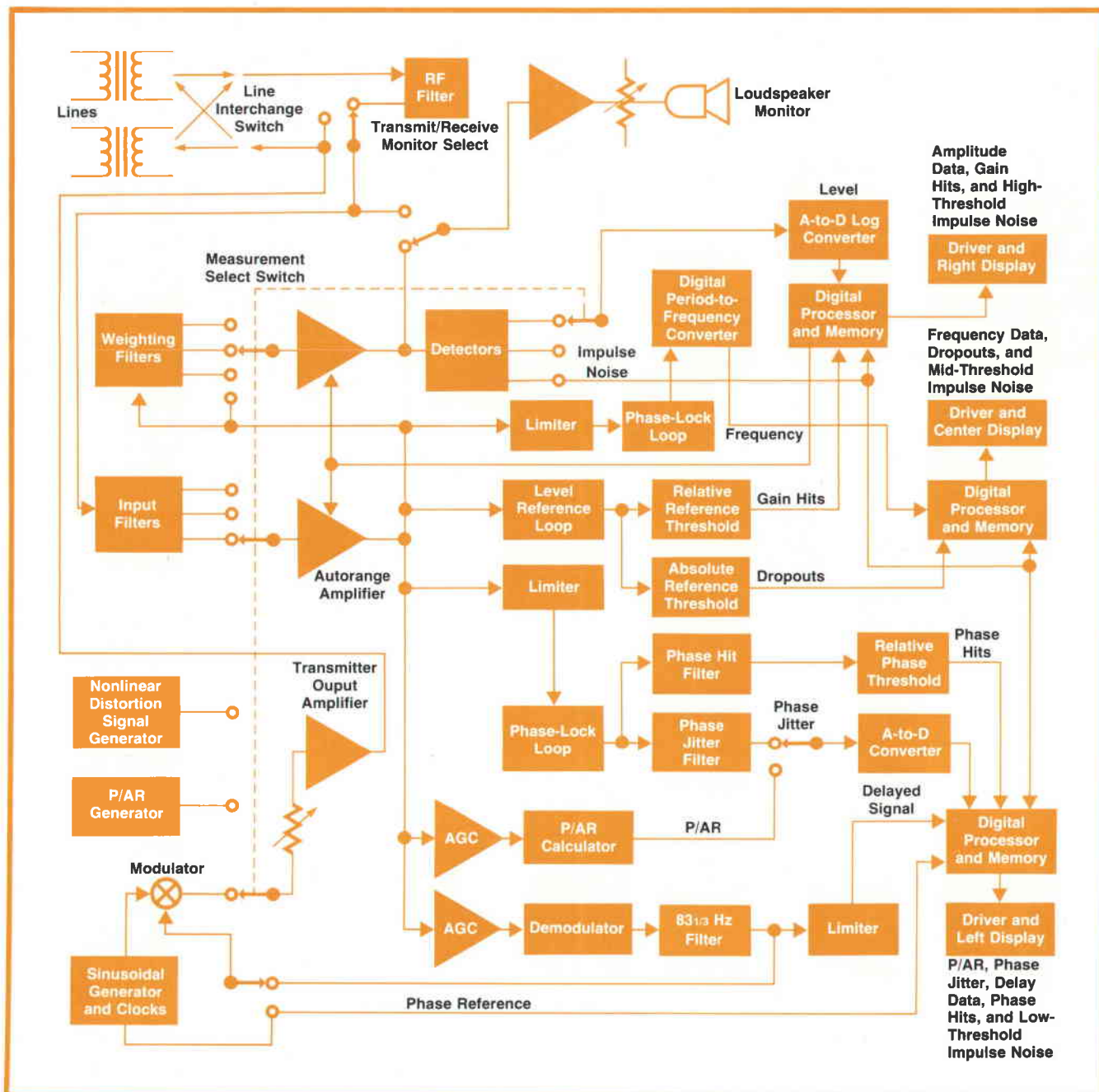

Fig. 3. Model 4940A TIMS is six instruments in one. Many circuits are shared by two or more measurements.

analog-to-digital converter and displayed on the left display field. The error signal from the loop is also available at an external connector for spectral analysis of jitter components.

The output of the carrier-tracking voltage-controlled oscillator is also available as a sync signal for viewing jitter components on an oscilloscope or for making high-resolution frequency measurements.

P/AR and Envelope Delay

P/AR or peak-to-average ratio is measured by

establishing a normalized signal level with an AGC loop and a fixed reference level after passing the input signal through a shaping filter. An analog calculator circuit solves the P/AR equation:

$$P/AR = 100 \left(2 \frac{P/P_o}{FWA/FWA_o} - 1 \right)$$

where P/P_o and FWA/FWA_o are the normalized peak and full-wave-rectified average values of the signal envelope. A dc signal proportional to this value is then quantized by the A-to-D converter and displayed by the left display.

Relative envelope delay is measured by the 4940A over a range of -3000 to $+9000$ microseconds with resolution of one microsecond and accuracy of ± 10 microseconds. An AGC circuit in conjunction with the autorange amplifier provides a precise signal level to the demodulator circuit, thus eliminating amplitude sensitivity. The recovered $83\frac{1}{3}$ -Hz modulation is filtered by a bandpass filter and is either used to remodulate a fixed-frequency carrier for return to a far-end measuring set (repeater function) or compared with the crystal-derived internal modulation source for phase shift (normal or measuring set function). In the normal mode the $83\frac{1}{3}$ -Hz signal is squared by a limiter and routed to a digital processor. Once an initial phase reference is established at a reference frequency, the digital processor calculates the net phase difference and then stores this value and subtracts it algebraically from subsequent readings. The net value of the relative delay is displayed with the correct sign; there is no need for any calculation by the operator. Twenty measurements are averaged for each display reading. The refresh rate is three per second.

Transmitters

One of three internal transmitters is selected by the choice of measurement. The transmitted amplitude is adjustable over a range of $+10$ dBm to less than -40 dBm. Setting the DISPLAY CONNECTED TO switch to TRANSMIT allows the unit to monitor the output level and, if appropriate, the output frequency. When switching between measurements all amplitudes remain constant with two exceptions. Because of the high crest factors of the nonlinear distortion and P/AR signals, output amplitude is limited to 0 dBm in these measurements.

In level/frequency and envelope delay measurements three modes of transmitter frequency control are available: continuously manually variable, stepable up or down in 100-Hz increments with 4-Hz offset ($f = 100N + 4$, where $2 \leq N \leq 39$), or incrementally swept through the same 100-Hz steps at a variable rate. The 4-Hz offset is provided to eliminate interference resulting from the 8-kHz sampling rate in PCM systems. In the swept mode, the automatic stepping action may be overridden manually if a reading is missed. The transmitter is phase-locked to an internal crystal-derived signal when it is in either of the step modes or when operating at the 1004-Hz fixed frequency in noise-with-tone, three-level impulse noise, hits and dropouts, or phase jitter measurements.

Another transmitter generates the P/AR signal. This signal approximates the spectral energy distribution of a data signal and has a precisely defined peak-to-average value, a parameter particularly sensitive to amplitude and phase distortion. A ROM is used to store a digital time domain representation of the P/AR

signal. An A-to-D converter and shaping filter complete the transmitter circuit. Crystal-derived clock drive insures spectral frequency accuracy and stability.

The third TIMS transmitter generates the multi-frequency signal used in measuring intermodulation distortion. Frequencies are obtained by division of a crystal-controlled source.

Self-Test

Built into the 4940A is a complete self-test system that allows an operator to verify the proper functioning and calibration of the set in every measurement. Placing the set in SELF-CHECK and rotating the measurement switch through each position with the transmit and receive inputs connected together and the DISPLAY CONNECTED TO switch in the RECEIVE position causes a series of calibration numbers to be displayed. Miscalibration or malfunction of either transmitter or receiver results in deviation of the calibration numbers from their proper values.

Acknowledgments

The author gratefully acknowledges the contribution of the many dedicated and talented people who contributed to the genesis of the 4940A. Ole Volhontseff and Art Kordes did the mechanical design; Don Dresch the NLD receiver, weighting filters and switching logic interface; Erhard Ketelsen the P/AR receiver and transmitter, and NLD transmitter; Dick Lee the power supply and sinusoidal transmitter; Paul Winninghoff the receiver front end, detectors, noise and transient measurements, and phase jitter circuits; Johann Heinzl the envelope delay circuits; and Dick Fowles the log converter and all digital signal processing. No project succeeds without management support and on this project it was generous. Not only were the division manager and engineering manager involved in product definition and project guidance, but they even became involved in prototype package assembly. Product manager Ray Baribeau was ever present. Thanks to all. 

References

1. J.R. Duerr, "A Data Error Analyzer for Tracking Down Problems in Data Communications", Hewlett-Packard Journal, February 1974.
2. T. Crawford, J. Robertson, J. Stinson, and I. Young, "A High-Speed Pattern Generator and an Error Detector for Testing Digital Systems", Hewlett-Packard Journal, November 1973.
3. B.W. Dudley and R.D. Peck, "High-Efficiency Modular Power Supplies Using Switching Regulators", Hewlett-Packard Journal, December 1973.
4. "Analog Parameters Affecting Voiceband Data Transmission—Description of Parameters", Bell System Technical Reference PUB41008, October 1971.
5. "Transmission Parameters Affecting Voiceband Data Transmission—Measuring Techniques", Bell System Technical Reference PUB41009, January 1972.

Transient Measurements

by Paul G. Winninghoff

Transient phenomena are a major cause of data communication problems, especially as the data rate approaches the channel capacity. Transient measurements are therefore an important part of data channel characterization.

Four transient phenomena of primary interest are called dropouts, gain hits, phase hits, and impulse noise. Measuring these phenomena has been imprecise, partly because of their random, sporadic nature—two successive measurements may yield very different numbers of events—and partly because of the difficulty of separating and classifying the different types of events. The 4940A TIMS is the first instrument capable of simultaneously recording hits, dropouts, and impulse noise and properly distinguishing one from another.

Dropouts are losses of signal carrier. The 4940A recognizes as a dropout a decrease in carrier level of at least 12 dB lasting at least 10 ms. The reference level is established at the beginning of a measurement. Sometimes when a dropout occurs the background noise rises simultaneously, so the total signal level may approximate the original carrier level. In the 4940A, a rate detector, a kind of digital bandpass filter, distinguishes between carrier and noise in such situations.

Gain hits are rapid changes in the channel gain. In the 4940A this is a relative measurement; the reference level is the level of the signal itself, delayed by 4 ms before comparison. The 4-ms delay allows the set to distinguish gain hits from impulse noise and dropouts. Time constants of the TIMS are chosen to match a typical modem AGC response time so that a slowly changing gain that can be tracked by a modem's AGC will not be counted as a gain hit. The gain hit threshold, selectable by means of a front-panel control, is 2, 4, 6, or 8 dB.

Phase hits are rapid phase changes in the channel. The phase reference is the signal itself delayed by 4 ms, and the 4940A time constants match those of typical modems. The phase hit threshold is selectable from 10 degrees to 45 degrees in five-degree steps.

Impulse noise consists of noise spikes that are much greater in amplitude than the average message-circuit noise envelope. These spikes are narrow, typically lasting less than 4 ms and occurring in bursts. The 4940A counts noise spikes that exceed three thresholds. The low threshold is set on the front panel and the middle and high thresholds are 4dB and 8dB above the low threshold.

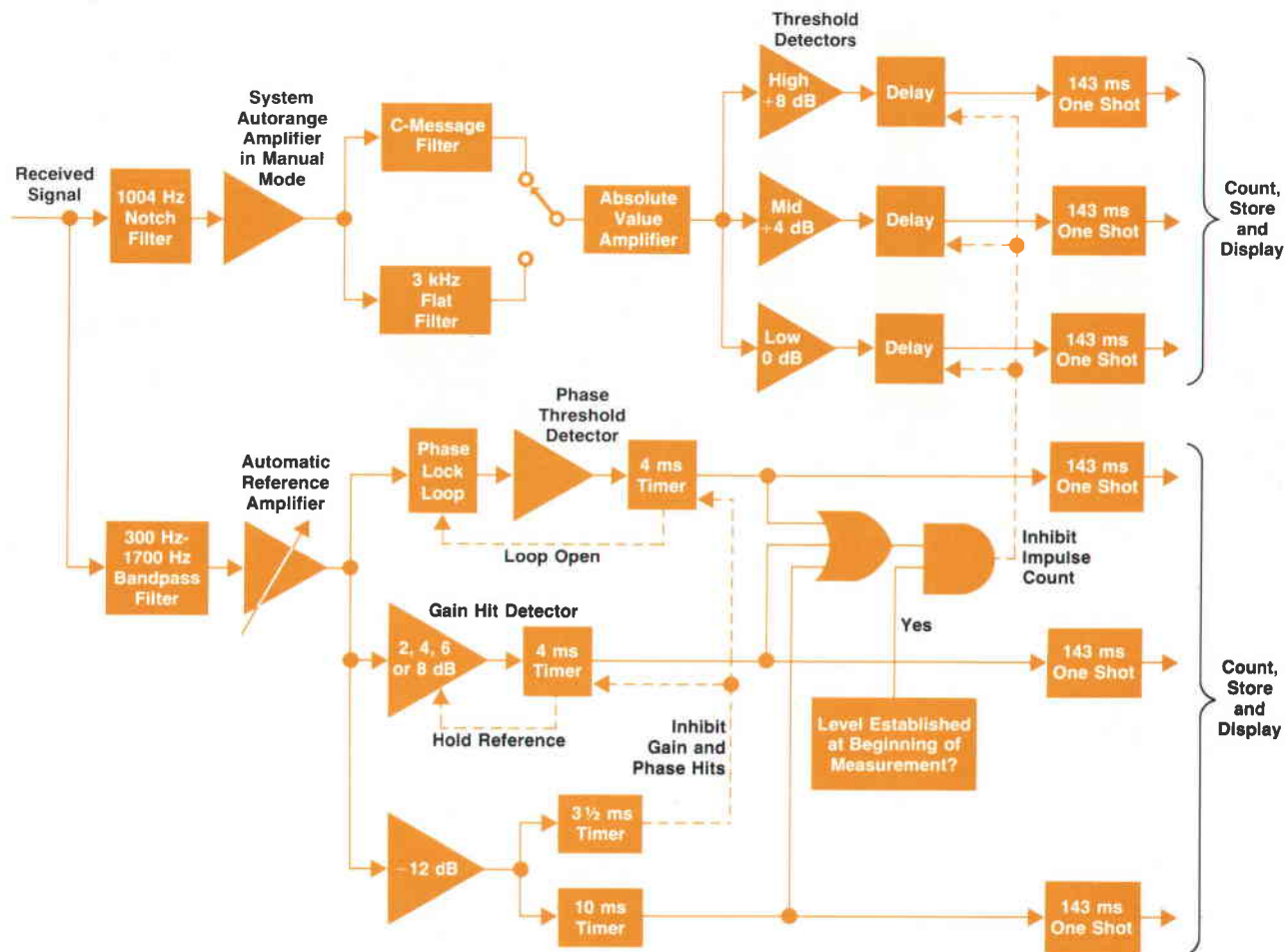

Event Counting

Transient measurements may be made over five-minute or fifteen-minute intervals, or continuously. During the measurement interval the cumulative counts of the six simultaneous measurements (dropouts, gain hits, phase hits, and three levels of impulse noise) are stored in internal memory. The three display fields register either hits and dropouts or impulse noise, depending on the position of a front-panel switch. The final counts remain stored after the end of a measurement until a new measurement is initiated.

An "in process" annunciator informs the operator that a measurement is under way. If the operator changes any critical switches (other than the threshold switches) while a measurement is in progress, the measurement is automatically suspended and the count memories reset to zero. This prevents invalid measurements.

Two count rates are provided. BELL STD limits the count rate to seven counts per second, matching the counting speed of earlier impulse noise sets that used mechanical counters. CHNL LTD (channel limited) allows counting at rates greater than 30 counts per second.

Transient Receiver

The diagram shows the receiver system that simultaneously measures dropouts, gain and phase hits, and three levels of impulse noise. As is true for all 4940A measurements, many of the blocks shown are shared with other measurements.

The top channel in the diagram measures three-level impulse noise and the bottom channel measures hits and dropouts. A 4-ms guard interval is provided so the hit detectors are not

confused by impulse noise spikes. Delay and store loops hold the reference levels during the 4-ms interval. To prevent dropouts' being counted as hits, the hit detectors are inhibited when a carrier loss of more than 12 dB lasts more than 3½ ms.

A measurement is initiated by the operator's pushing the START/RESET button. This sets the automatic reference amplifier in the lower channel to minimum gain. The gain then increases until the output of the automatic reference amplifier reaches a preset level. The timed interval begins after this level has been reached.

Event Discrimination

Any transient disturbance of the carrier generates frequency components outside the 1004-Hz notch filter in the impulse noise channel and therefore simulates impulse noise. Thus the simultaneous measurement of hits, dropouts, and impulse noise poses the problem of event discrimination. The 1004-Hz carrier is necessary for simultaneous measurements, of course, but it is also needed to activate companders, if present in the channel, and to make the impulse noise measurement representative of the channel under operating conditions.

To solve the discrimination problem, recording of impulses is delayed and an inhibit is provided to prevent an event's being recorded as an impulse if it records as a gain hit, a phase hit, or a dropout. The hit and dropout detectors are not easily confused by impulses.

If no carrier is present at the beginning of the measurement the inhibit signal is not generated. This allows impulse noise to be measured with no carrier present. A minus sign annunciator in the right display warns the operator that there is no carrier.

The 4940A Sine Wave Transmitter

by Richard T. Lee

The 4940A sine wave transmitter generates audio frequency signals that are either continuously variable from 200 to 3900 Hz or steppable in 100-Hz increments from 204 to 3904 Hz. It uses a BFO (beat-frequency-oscillator) circuit technique to minimize distortion and to provide at each frequency step the fixed 4-Hz frequency offset necessary to test channels containing PCM systems. A programmable frequency synthesizer provides stable, phase-locked, stepped frequencies at precise 100-Hz increments. The sine wave output can be amplitude-modulated at 83⅓ Hz for testing data lines for envelope delay distortion.

The overall block diagram is shown in Fig. 1. Two crystal oscillators at 9.996 MHz and 10.000 MHz produce the primary signals for transmitter operation: a 20-kHz square wave reference signal for the frequency synthesizer and a 9.996-kHz square wave fixed-frequency input to the BFO mixer.

The frequency synthesizer can be operated in either a programmable phase-locked mode or an open-loop mode (in which case it may be considered simply a voltage-controlled oscillator). In the phase-locked mode the synthesizer generates signals in 100-Hz steps from 10.200 kHz to 13.900 kHz. The actual frequency depends on BCD information from the step-100-Hz circuit. This BCD information may be overridden by a command bit from the system logic control to produce an 11.000-kHz output; this is done whenever a fixed 1004-Hz signal is wanted for noise-with-tone, transient, and phase jitter measurements. In the open-loop mode a tuning voltage from the front-panel manual frequency control directly varies the VCO frequency between 10.2 kHz and 13.9 kHz.

In the BFO mixer the frequency synthesizer output acts as a

local oscillator signal and mixes with the 9.996-kHz input. The result is a chopped signal containing a desired frequency from 204 Hz to 3904 Hz, various harmonics of this frequency, higher-order mixing products, and feedthrough of the input frequencies. Filtering the 9.996-kHz input square wave attenuates harmonics and lower-frequency mixing products, and passing the mixer output through the 4-kHz low-pass filter removes the feedthrough and higher-frequency mixing components.

The sine wave signal from the 4-kHz low-pass filter may be modulated by an 83⅓-Hz tone generated either internally in the transmitter (normal modulation mode) or recovered from an input signal in the receiver section of the 4940A (repeat modulation mode). The 83⅓-Hz sine wave used in the normal mode is crystal-oscillator-derived and is processed in a digital low-pass filter. The digital filter has the stable phase-shift characteristics that are essential for accurate envelope delay distortion measurements.

The sine wave transmitter may be operated in a "signaling frequency skip" mode, its output shut off in the range 2450 Hz to 2750 Hz. A frequency discriminator converts the sine wave signal from the 4-kHz filter to a dc analog voltage that is fed to a window comparator. When the analog voltage falls between two reference input voltages the window comparator is activated, opening the FET switch at the transmitter output.

Programmable Frequency Synthesizer

As shown in Fig. 2, the frequency synthesizer is a phase-locked loop consisting of a voltage-controlled oscillator, a programmable frequency divider, and a phase detector and low-pass filter.

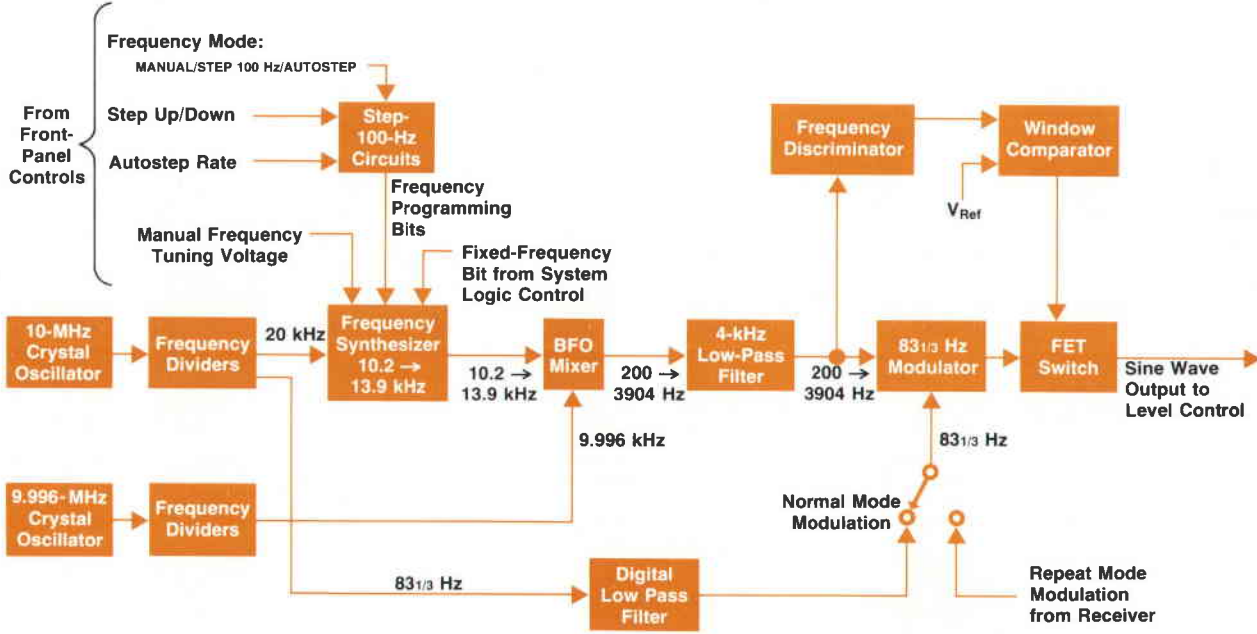

Fig. 1. 4940A sine wave transmitter block diagram

The VCO is an emitter-coupled multivibrator with varactor diode tuning elements. The VCO frequency has a nominal range of 2.04 MHz to 2.78 MHz. Temperature coefficient varies from a maximum of 200 ppm/°C at the lowest output frequency to less than 100 ppm/°C at the highest frequency. After buffering, the VCO output signal is divided in frequency by 200 and becomes the 10.2-kHz-to-13.9-kHz local oscillator signal applied to the BFO mixer.

A programmable divider operates on the 2.04-to-2.78-MHz VCO signal and presents to the phase detector a 20-kHz signal that is phase-locked to a 20-kHz reference frequency when the loop is closed. Three cascaded modulo-N counters and a BCD data selector form the programmable divider. The divisor is $100+N=(100+10P+Q)$, where P and Q are the tens and ones digits respectively. As indicated in Fig. 2, $100 \leq 100+N \leq 139$; however, divisor values of $100+N=100$ or 101 are prohibited by the step-100-Hz logic. Since the output of the programmable divider is constrained to be precisely 20 kHz in the phase-locked condition,

$$f_{VCO} = 20,000(100+N)$$

where $N = 2, 3, \dots, 39$.

There is a convenient direct relationship between N and the transmitter output frequency: $N=2$ corresponds to $f_{out} = 204$ Hz $N=3$ to $f_{out} = 304$ Hz, and so on. Each phase-locked frequency is accurate within ± 0.5 Hz.

A fixed-frequency bit from the system logic control causes the BCD data selector to apply $P=1, Q=0$ to the counter chain, resulting in a fixed-frequency transmitter output of 1004 Hz.

The phase detector converts input phase differences to output currents. A low-pass filter integrates these currents to dc and slowly varying ac voltages that are applied to the VCO tuning input. The bandwidth of the filter is 500 Hz, low enough to allow the loop to lock to the 20-kHz reference, but high enough so that low-frequency disturbances (such as 60 Hz) originating within the loop are attenuated by the action of the loop.

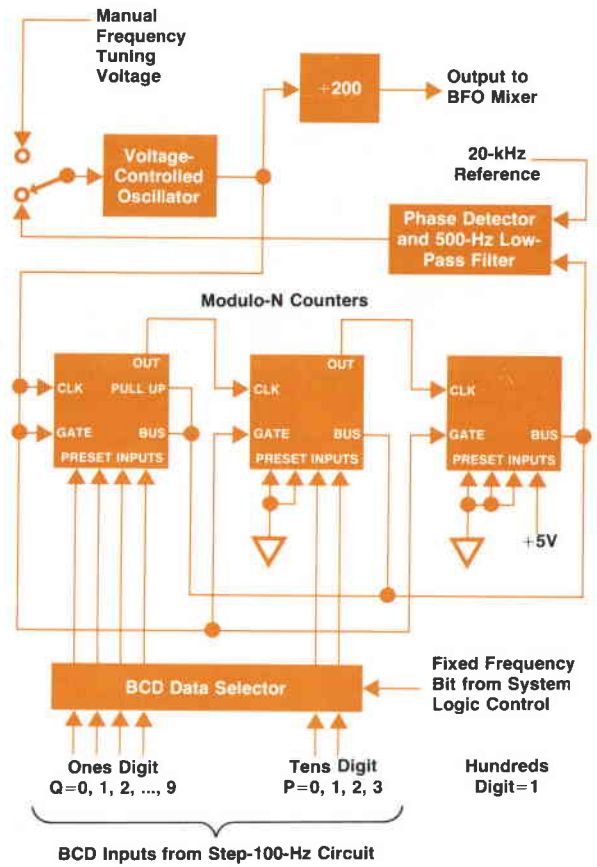

Fig. 2. Programmable frequency synthesizer

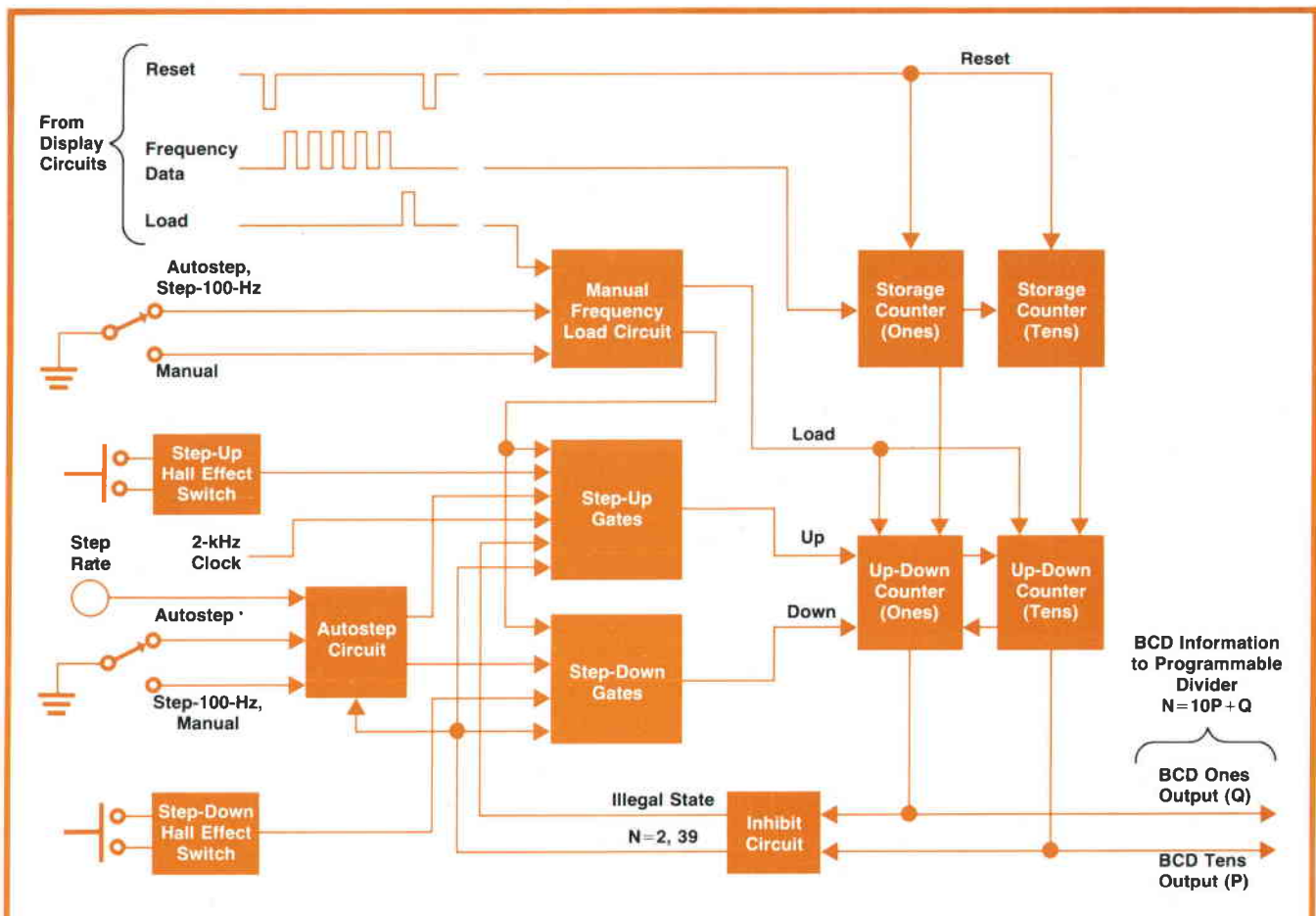

Fig. 3. Step-100-Hz circuit

The Step-100-Hz Circuit

Fig. 3 is a diagram of the step-100-Hz circuit. The key blocks of this circuit are the two up-down counters that furnish BCD ones and tens digit information to the programmable divider in the frequency synthesizer. These up-down counters can operate in two ways: pulses may be applied to the count-up or count-down inputs of the ones counter from either single-step front-panel switches or an autosteping circuit, or information present at their data inputs may be loaded into the counters, determining their outputs. Circuit operation guarantees that these two situations are mutually exclusive.

The up-down counter outputs can be changed in single-step increments by operation of the front-panel step-up or step-down Hall-effect pushbutton switches. The TTL pulse resulting from each push operation travels through a number of step-up or step-down gates to the appropriate count input on the ones up-down counter. During this STEP 100 HZ mode, the autostep circuit is deactivated. The up-down counters are prevented from counting below $N=2$ or above $N=39$ by an inhibit circuit that locks out input pulses to the step-down or step-up gates respectively. When the instrument is turned on, any illegal states (e.g., $N < 2$, $N > 39$, $P > 3$, P or $Q > 9$) present in the up-down counters are sensed by the inhibit circuit, which then allows a 2-kHz clock to run through the step-up gates, stepping the up-down counters until they reach an allowed state, whereupon normal operation begins.

With the front-panel FREQUENCY CONTROL switch in the

AUTOSTEP position TTL pulses from the autostep circuit continuously pass through the step-up gates to the up-down counters until $N=39$. These pulses are then rerouted through the step-down gates until $N=2$. The sequence then repeats. The time interval between steps is adjusted by a front-panel STEP RATE control to be between 0.25 second and 7 seconds. The step-up/down pushbutton switches remain activated in this mode.

When the FREQUENCY CONTROL switch is set to MANUAL and the operator wants to change to the STEP 100 HZ mode, he simply turns the switch to this position. If the transmitter has been manually tuned to f_{out} , where $100N \leq f_{out} < 100(N+1)$, the frequency will phase-lock at $f_{out} = 100N + 4$ Hz when the change is made. This is implemented as follows. In the MANUAL mode an output from the manual frequency load circuit locks out the TTL pulses from the Hall-effect switches and the autostep circuit. A repetitive sequence of three digital signals arrives at the step-100-Hz circuit from the 4940A display circuits. First, a RESET pulse zeros the storage counters. Then a FREQUENCY DATA pulse burst arrives at the input of the ones storage counter, and the count information is presented at the storage counter outputs in BCD form. The number of pulses in each burst equals the two most significant digits of the 4940A frequency display reading (that is, the number of pulses is N). A LOAD pulse then transfers the information in the storage counters to the up-down counters. Thus these counters always contain the current value of N . The LOAD pulse is locked out in the STEP 100 HZ and AUTOSTEP modes.

Nonlinear Distortion Measurements

by Donald A. Dresch

Nonlinear distortion as used here means the generation of unwanted signals as a result of nonlinear operations on a desired signal or group of signals. Harmonic distortion is one well-known example; if the main signal is a sine wave of frequency F , the unwanted signals appear as sine waves at $2F$, $3F$, and so on.

Harmonic distortion is often used as a measure of nonlinear distortion in voice channels because harmonic distortion is easily measured with readily available equipment. However, any conclusion about the nonlinearity of a telephone channel based on harmonic distortion measurements is subject to gross errors. If two identical nonlinearities in a channel are separated by a linear network that has just the right phase characteristic, the distortion products from a single transmitted sine wave may combine in such a manner that the energy of a particular harmonic from one nonlinearity may completely cancel the energy of that harmonic from the second nonlinearity. At the other extreme, a different phase characteristic may cause distortion voltages from the two nonlinearities to add, showing four times the power level at that harmonic that would be produced by each source separately. Because a telephone channel may contain several nonlinearities separated by linear networks, harmonic measurements will yield different results for different test frequencies as a result of variations in channel delay with frequency. If the channel contains a frequency multiplexed system, frequency offset may occur and harmonic distortion measurements may show a very-low-frequency "breathing" or beat with time.

The nonlinear distortion measurement in the 4940A takes a different approach that minimizes these problems. In the TIMS transmitter, count-down chains from a crystal oscillator create two pairs of tones, A and B. The A pair is centered at 860 Hz and separated by 6 Hz, and the B pair is centered at 1380 Hz and separated by 11 Hz. Nonlinear distortion is measured by detecting the intermodulation products created when this signal is transmitted through the voice channel. Second-order distortion is measured by selectively filtering, power summing and detecting the energy at the $A+B$ and $A-B$ frequencies. Third-order distortion is measured by filtering and detecting the $2B-A$ frequencies. Second-order distortion products consist of eight distinct frequencies, while third-order products consist of four distinct frequencies. Together all these frequencies approximate narrow-band noise in amplitude distribution. This reduces the sensitivity of the measurement to envelope delay and frequency offset characteristics.

Tests have shown that the frequency dependence and time variability problems of harmonic distortion measurements are not completely eliminated by using the intermodulation technique. However, they are greatly reduced in most cases. Second-order distortion measurements on channels with different amplitude and envelope delay characteristics produce varying results when amounts of distortion are low. However, in practical applications there is good general agreement when the amount of second-order distortion is of sufficient magnitude to be of interest, and in the case of multiplexed channels, if readings are averaged over a 20-to-30-second interval. Third-order distortion measurements also exhibit a reduced sensitivity to time and delay distortion variability because the A and B frequencies and the third-order $2B-A$ product are near the center of the band where the channel's envelope delay characteristic is typically flat.

There were other considerations for the selection of A and B frequencies. The second-order products must be somewhat immune to the effects of channel roll-off, and the second and third-order products must be separated by at least 300 Hz from any signal components to minimize the effects of phase jitter on distortion readings. The frequencies chosen meet these requirements.

The effect of background noise on the measurement is determined by doubling the power of the A frequencies and disabling the B frequencies. Level-sensitive circuits such as syllabic companders are kept at their operating levels while the noise in the narrow-band $A-B$, $A+B$, and $2B-A$ slots is measured. A correction factor can then be applied to the measurements as shown in Fig. 1.

NLD Transmitter

The block diagram of the nonlinear distortion transmitter is shown in Fig. 2. The four A and B frequencies are synthesized from programmable countdown chains, all fed from a common crystal oscillator. The A and B frequency pairs are added separately and low-pass filtered, then added together. In the output summing circuit, a transistor switch doubles the gain of the amplifier and disables the B count-down chains for background noise measurements.

NLD Receiver

Fig. 3 is a block diagram of the nonlinear distortion receiver. Before notching out the fundamental frequencies the received signals are high-pass filtered to remove any signals at 60 Hz and its harmonics. The notch filters reject the A and B frequencies by 50 dB. Depending on whether it is the signal, the second-order level, or the third-order level that is being measured, narrow-band filters are automatically switched in or out. A quasi-rms detector detects the signals. As in all other measurements, level ranging, level referencing, "+" and "-" indicators, and dB/dBm indicators are completely automatic. Readings are stabilized approximately four seconds after a pushbutton selection has been made.

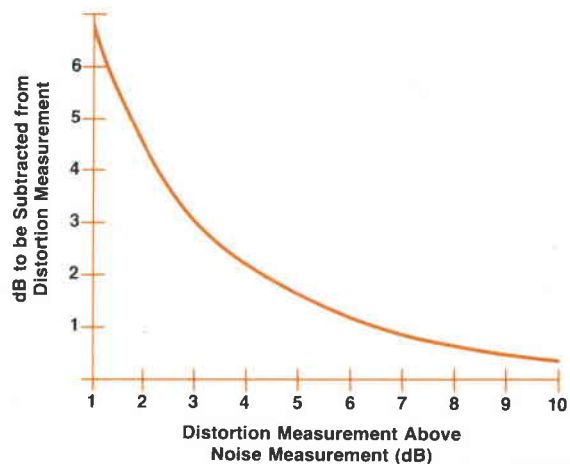

Fig. 1. Correction factor is applied to nonlinear distortion measurements to eliminate noise contribution.

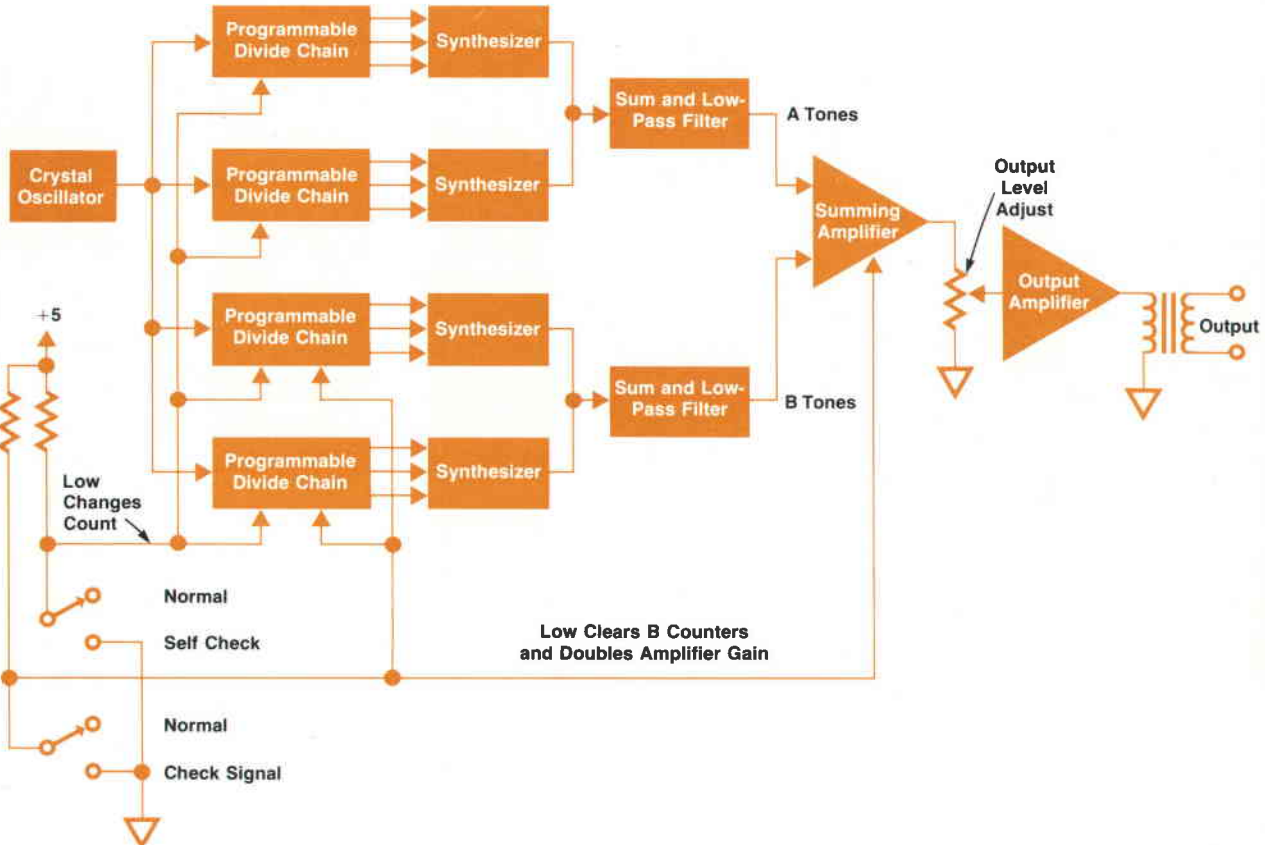

Fig. 2. 4940A nonlinear distortion transmitter

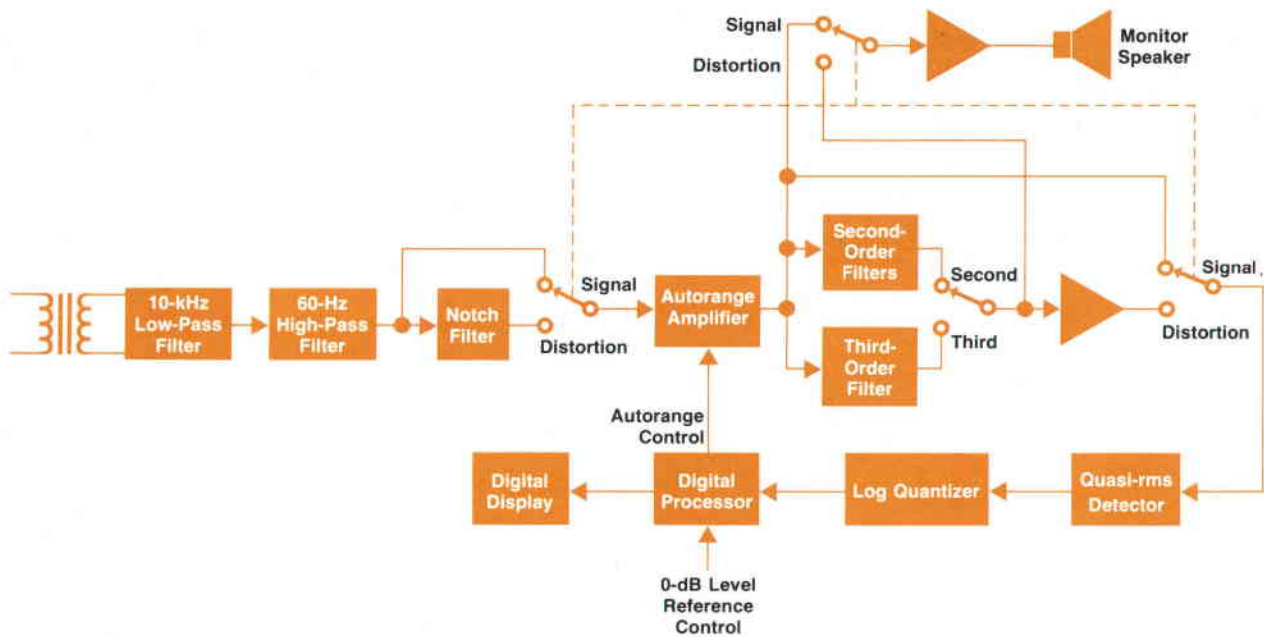

Fig. 3. 4940A nonlinear distortion receiver

Envelope Delay Distortion Measurements

by Richard G. Fowles and Johann J. Heinzl

Phase delay distortion and envelope delay distortion are often confused. Phase delay is insertion phase shift divided by frequency, ϕ/ω . Envelope delay is the first derivative of phase with respect to frequency, $d\phi/d\omega$ (see Fig. 1). Phase delay distortion and envelope delay distortion occur when phase delay and envelope delay, respectively, vary nonlinearly with frequency. It is possible to have phase delay distortion without envelope delay distortion, but envelope delay distortion is always accompanied by phase delay distortion.

Voice transmission is not affected by envelope delay distortion or phase delay distortion because intelligibility is not impaired by phase shift. However, electronic equipment such as data modems may be very sensitive to such distortion because waveforms may be considerably altered. In the special case of pure phase delay distortion, information transmitted by an amplitude, frequency, or phase-modulated signal is not affected because the amplitudes and relative phases of sidebands and carrier are not changed. Envelope delay distortion or EDD, on the other hand, is very troublesome.

Method of EDD Measurement

The 4940A EDD measurement is based on the Nyquist and Brand method.¹ A carrier signal is amplitude modulated with a low-frequency signal. The phase shift encountered by the envelope of the transmitted signal is a measure of envelope delay at that carrier frequency. Although envelope delay is an absolute quantity, the 4940A measures relative envelope delay, that is, envelope delay as a function of carrier frequency with respect to a fixed but arbitrary carrier frequency. This has no effect on the measurement of distortion, which is determined by measuring the variation in relative envelope delay over the frequency band. The 4940A is compatible with other envelope delay test sets used by the telephone companies in the U.S.A. and Canada.

In voiceband measurements, envelope delay distortion is usually referenced to a carrier frequency near 1800 Hz. In the typical channel the envelope delay characteristics are flat and a minimum in this region. The modulation index of the EDD test signal is 50% and the modulation frequency is 831/3 Hz.

To make an EDD measurement, two TIMS are used. The TIMS normal test set transmits a test signal over the channel under test to the TIMS repeat test set. The repeat set responds

by transmitting envelope delay information back to the normal set over the return reference voice channel. The normal set compares its received signal with its transmitted signal to determine envelope delay distortion values.

The normal set transmits an amplitude-modulated test signal consisting of a variable-frequency carrier (300 to 3904 Hz) and a fixed modulation frequency (831/3 Hz). The carrier frequency is varied over the band of interest, usually in 100-Hz steps. The test signal traverses the voice channel under test and is received by the repeat set. The receiver of the repeat set amplitude-demodulates the incoming test signal and then uses the recovered modulation to amplitude-modulate a fixed-frequency carrier that is transmitted back to the normal set. The fixed repeat-set carrier frequency is usually selected near midband (1800 Hz). Because the repeat-set carrier frequency is fixed, no envelope delay distortion is encountered by the return reference signal, although there is a fixed envelope delay. Therefore, the envelope delay value received at the normal set represents the envelope delay value received at the repeat set, plus the constant envelope delay of the return reference channel.

The receiver of the normal set demodulates the incoming return reference signal. The phase of the incoming return reference envelope is then compared to the original 831/3-Hz oscillator signal to determine the difference in phase between the two signals.

At the beginning of the measurement a DELAY ZERO control is used to cancel the envelope delay of the measurement loop. All future measurements are then referenced to the normal-set carrier frequency at which the delay was zeroed (usually near 1800 Hz).

EDD Analog Circuits

Fig. 2 shows the 4940A EDD receiver circuits. The received envelope delay signal passes first through a 10-kHz low-pass filter and an autorange amplifier that keeps the output level within a 12-dB range for input signal variations up to 50 dB. An automatic level control circuit guarantees a nearly constant 831/3-Hz signal amplitude at the demodulator and limiters. This is important because level changes here would cause small delay errors.

A full-wave rectifier is used to demodulate the envelope delay signal. Low-pass filters 1 and 2 recover the 831/3-Hz modulation. The higher the Q of these filters the higher is the attenuation of unwanted interference tones, harmonics, and noise. Unfortunately, an increase in Q also results in an increase of pole location drift with temperature. This causes a phase shift and therefore an error in the envelope delay measurement. To overcome this problem, a special control loop was designed. The loop compares the phase of the demodulated 831/3-Hz signal at the output of high-Q filters 1 and 2 with that of the same 831/3-Hz signal at the output of low-Q filters 3 and 4. The low-Q filters are very temperature stable and serve as a phase reference.

A change in pole location in the high-Q filters (e.g., because of a change in temperature) changes the insertion phase shift at 831/3 Hz. This phase shift is measured in a phase detector and the detector output voltage is compared to a fixed dc reference voltage. The difference is amplified by a differential amplifier, which controls a voltage-dependent resistor in low-pass filter 1. Varying this resistor's value changes the pole location and the insertion phase shift through that filter. The result is a

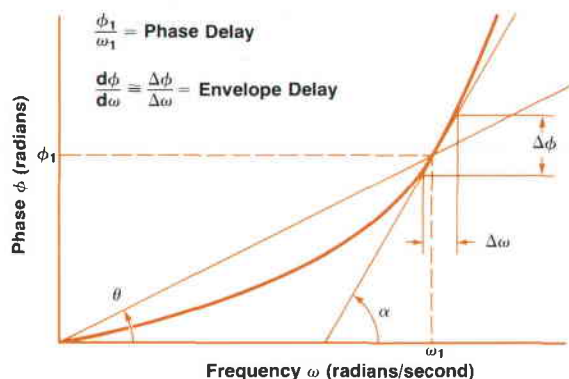

Fig. 1. Phase delay and envelope delay defined.

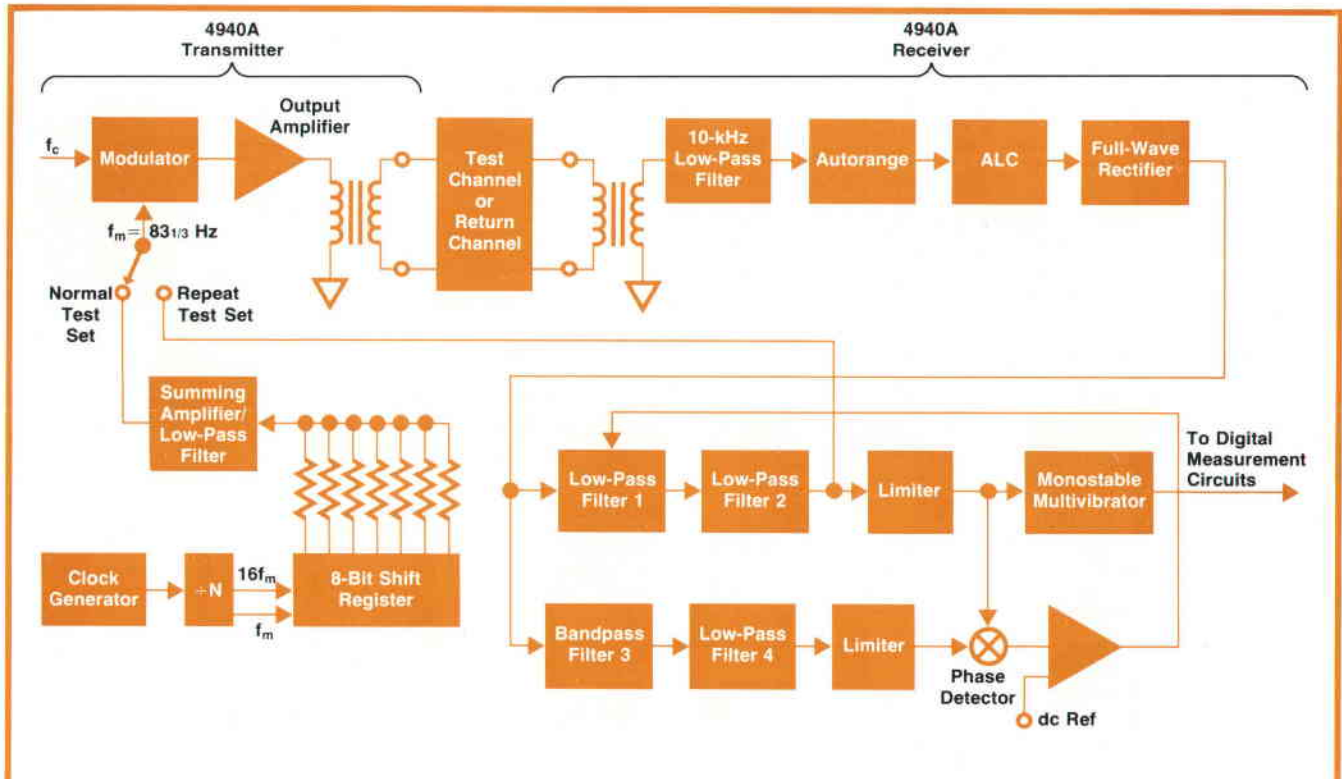

Fig. 2. 4940A envelope delay transmitter and receiver circuits

filter that has high-Q amplitude response and low-Q phase stability. Its temperature stability virtually eliminates warm-up time and the need for a constant ambient temperature to make an accurate envelope delay measurement.

Delay changes with temperature in the transmitter are mini-

mal because the modulation signal is synthesized digitally by summing of the outputs of an 8-bit shift register. This technique overcomes the significant temperature drift of analog filters.

EDD Digital Circuits

From the receiver circuits shown in Fig. 2, the filtered 83 1/3-

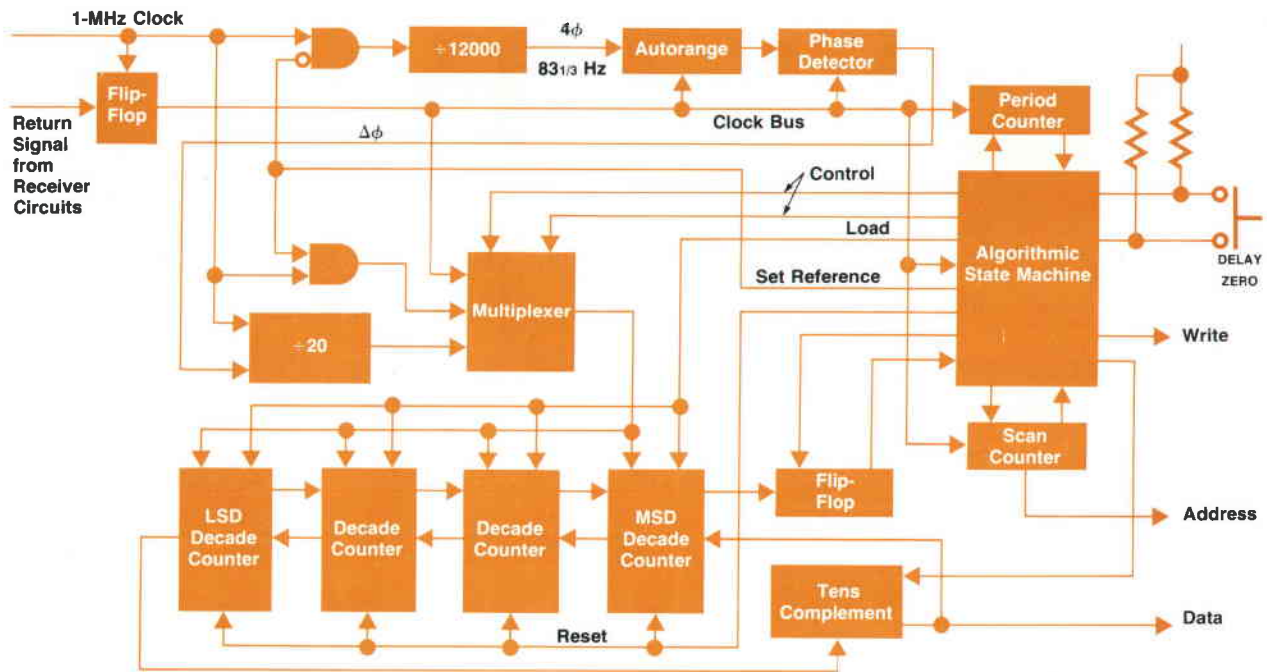

Fig. 3. 4940A envelope delay measurement circuits

Hz output goes to the digital measurement circuits shown in Fig. 3. The measurement is controlled by an algorithmic state machine.²

The dynamic range of the measurement circuits is 12,000 microseconds, distributed as $-3000 \mu\text{s}$ to $+9000 \mu\text{s}$ from a selectable arbitrary reference. 12,000 μs corresponds to one period of the modulation frequency of $83\frac{1}{3}$ Hz.

The $83\frac{1}{3}$ -Hz signal from the receiver circuits is first synchronized with the 1-MHz clock signal and then compared in the phase detector with a reference signal from the phase auto-range circuit. Fig. 4 is a diagram of the phase detector. The detector triggers on the leading edge of either input signal: the reference signal sets the phase detector and the return signal resets it. The output pulse width of the phase detector is therefore a measure of the phase difference.

In a practical circuit, noise causes degradation of the response, as shown in Fig. 5. To meet the accuracy requirement of $\pm 10 \mu\text{s}$, the phase detector must operate in the linear window shown in Fig. 5. For the specified worst case $(S+N)/N$ of 20 dB and a 3.9-kHz bandwidth this window is 11,600 μs wide.

To establish that the phase detector is operating in the linear window a phase autorange circuit (Fig. 6) is activated each time the DELAY ZERO button is pressed. This circuit steps the phase in 90° increments and remains enabled until the phase difference is between 90° and 270° . The arbitrary reference for the measurement is then established by measuring the initial phase relationship between the reference and return signals and then delaying the reference signal until the desired reference phase exists. In practice, the reference phase difference is not arbitrary; it is always set to 90° when the DELAY ZERO button is pressed.

Measurement Procedure

To make an envelope delay distortion measurement the reference phase difference is set at 90° with the reference signal leading the return signal. The carrier frequency at which this is done is arbitrary; however, 1804 Hz is generally used. With the reference established, the measurement proceeds by initializing a $4\frac{1}{2}$ decade counter at 17000. The leading 1 indicates a negative number and 7000 is the tens complement of 3000; thus the number preset into the counters is -3000 . This removes the initial phase difference of 90° . Twenty samples of the phase detector output are allowed to gate 1-MHz clock pulses into the $4\frac{1}{2}$ decade counter. If the delay has increased the counter overflows and resets the overflow flip-flop, and the number in the counter is displayed. If the delay had decreased the counter would not have overflowed. (This indicates a phase detector output of less than 90° .) In this case before

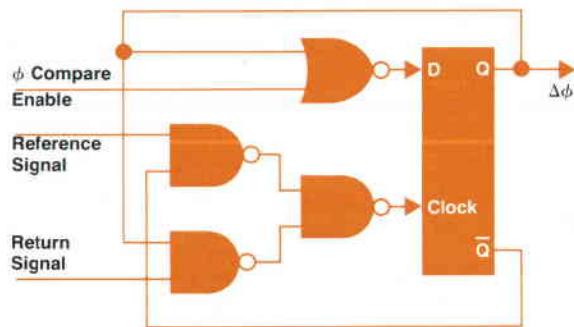

Fig. 4. Envelope delay phase detector

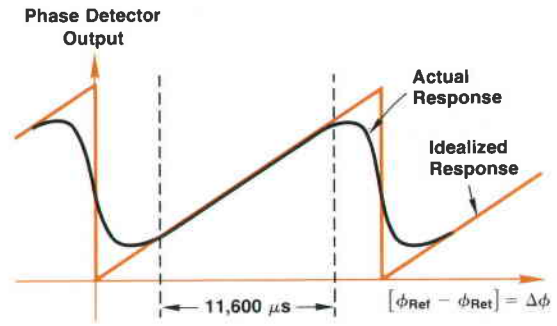

Fig. 5. Phase detector output versus phase difference. To avoid noise-produced deviations from the ideal curve, the detector must operate within the 11,600 μs window shown.

being displayed the number in the counter is tens complemented to put it in proper sign-magnitude form.

The use of the digital display in the measurement of envelope delay offers the advantage of having accuracy and resolution independent of displayed magnitude. But along with this advantage came the digital display's main disadvantage: poor readability for noisy signals. Noise is especially troublesome in phase measurements. The problem was reduced by keeping system bandwidth as narrow as possible in the detector, by averaging 20 samples to reduce noise before displaying the result, and by using a display refresh rate consistent with visual response (three times per second). The result is a mean variation of $\pm 50 \mu\text{s}$ out of a possible 12,000 μs for an input $(S+N)/N$ of 20 dB over a 3.9-kHz bandwidth.

References

1. H. Nyquist and S. Brand, "Measurement of Phase Distortion," Bell System Technical Journal, May 1930
2. R. E. Felsenstein, "The 5345A Processor: An Example of State Machine Design," Hewlett-Packard Journal, June 1974.

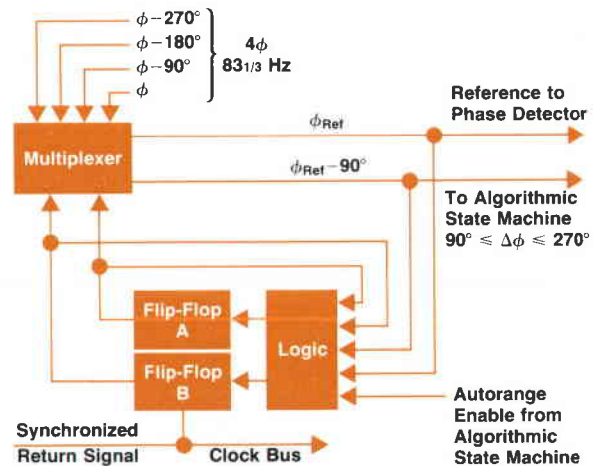

Fig. 6. Phase autorange circuit keeps the phase detector within its linear operating region.

Peak-to-Average Ratio Measurements

by Erhard Ketelsen

Because of the demand for increasing numbers of data-quality telephone channels, a quick means of identifying degraded channels has been sought by the telephone industry. A successful method would eliminate unnecessary measurements on good channels and allow maintenance personnel to concentrate further measurements on degraded channels to locate impairments and repair the channels.

To meet this need, the peak-to-average ratio (P/AR) measurement was developed by Bell Laboratories. Pulses of known peak-to-average ratio are transmitted through a communication channel. At the receiving end the peak-to-average ratio of the pulses is measured, normalized, and displayed. A reading of 100 signifies no pulse degradation.

Any change in the phase relationship of the frequency components of the pulse modifies the pulse shape (primarily by spreading it in time), and therefore the P/AR measurement is very sensitive to envelope delay distortion. Noise, changes in the transfer characteristic of the channel, and repeater amplifier clipping also affect the P/AR reading.

The transmitted pulses are shaped to simulate a data signal. The major portion of the energy is distributed near the center of the voice band. The pulse spectrum contains 16 frequency components from 125 + 15.625 Hz to 3875 + 15.625 Hz (Fig. 1).

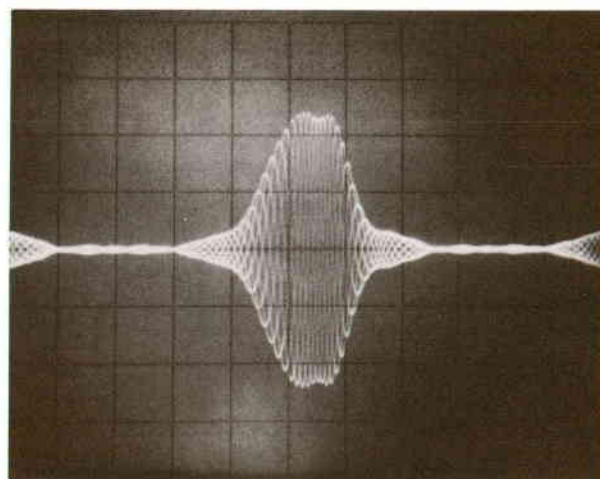
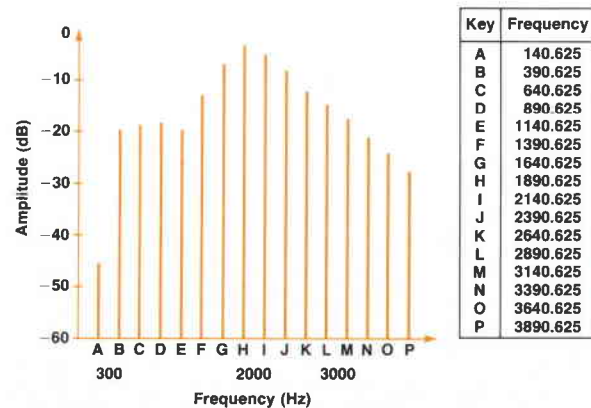

Fig. 1. Frequency spectrum and envelope of transmitted signal for peak-to-average ratio measurements.

Without the offset of 15.625 Hz, the spectral lines are all odd harmonics of the lowest frequency, 125 Hz. The absence of even harmonics produces a pulse train with half-wave symmetry, eliminating a problem of earlier P/AR instruments where reversing the line polarity would result in a different P/AR reading.

Another difficulty in making P/AR measurements is what is commonly called "breathing". In a carrier system, although the carrier frequency of the transmitter is crystal controlled, it may differ from the carrier frequency used in the demodulation process at the receiver. When the frequency difference is less than 2 Hz it causes a slow variation in the phase relationship of the spectral components, which causes the magnitude of the pulses to change slowly. If the detector in the P/AR receiver follows the changes, the readings may vary by a large amount from their average value. The 15.265-Hz frequency offset in the 4940A increases the rate of magnitude variation so the changes are easily integrated by the detector.

To prevent amplifier saturation in the communication channel, the crest factor of the 4940A pulse train is limited to 10 dB. Crest factor is the ratio of peak voltage to rms voltage. Crest factor is important because it determines the dynamic range required for system linearity. A system may operate linearly when the signal is a sine wave but begin clipping when a non-sinusoidal signal of the same rms level but higher crest factor is transmitted. Limiting the crest factor to 10 dB assures that this will not occur.

How It's Done

In earlier P/AR sets the receiver was required to cope with the effect of frequency translation of the P/AR spectrum by the carrier system (breathing). Filters and phase equalizers made the receiver complex and expensive. In these early sets the P/AR signal was generated by means of a pulse generator and shaping filters. In the 4940A an offset P/AR spectrum is generated digitally in the transmitter, and the receiver becomes very simple.

The 4940A uses a 4096-bit read-only memory (ROM) to generate the pulse train (see Fig. 2). The ROM is programmed with the time-domain representation of the offset frequency spectrum. It is driven by a crystal oscillator to guarantee that the spectral lines are at the correct frequencies.

The ROM output repeats each 64 milliseconds, but because

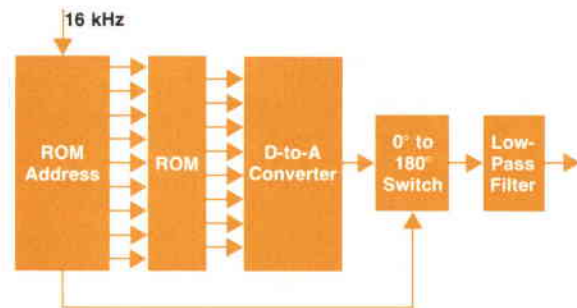

Fig. 2. P/AR signal waveform is stored in a read-only memory in the 4940A. This method of generation allows the receiver to be much less complex and expensive than previous methods.

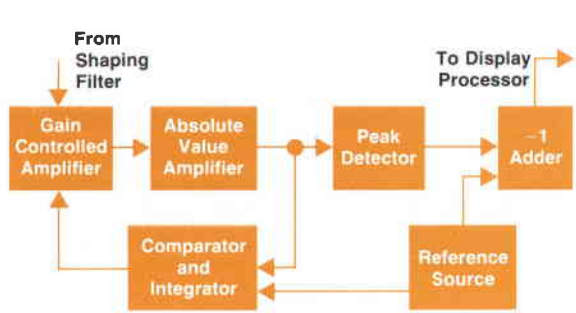

Fig. 3. P/IAR calculator.

the pulse train has half-wave symmetry, only the first 32 ms are stored. The ROM is organized into 512 8-bit words and is sampled at a rate of 62.5 microseconds per word ($512 \times 62.5 \mu s = 32 \text{ ms}$). The sampling frequency of 16 kHz is high enough so that aliasing does not occur.

A 5-kHz low-pass filter keeps out-of-band signal energy 40 dB below the transmitter level and smooths the output waveform. The information in the ROM is pre-emphasized to compensate for the gain and phase changes that occur as the pulses go through the smoothing filter.

At the receiving end P/IAR is calculated using the following equation:

$$P/IAR = 100 \left(2 \frac{P/P_o}{FWA/FWA_o} - 1 \right)$$

where P_o and FWA_o are the peak reading and full wave average readings of the transmitted pulse train. Since P_o and FWA_o are constants, the equation can be written as

$$P/IAR = 100 \left(k \frac{\text{Peak}}{\text{FWA}} - 1 \right)$$

The received pulse is shaped by a fourth-order band-pass filter that has a center frequency of 1300 Hz and a Q of 3.1. The shaping filter reduces the effects of power-line frequency interference and modifies the pulse train before detection.

The filter's response was calculated to minimize the crest factor of the transmitted signal while maintaining the same frequency spectrum at the detector input. This was done on an iterative basis by crosscorrelation of a trial filter function with the desired filter output (detector input). Then the time-domain transform was taken, the peak and rms values of the waveform were calculated, and the resulting crest factor was plotted as a function of pole location. The resulting plot was a cone-shaped contour map with the minimum crest factor at its apex. The 4940A shaping filter is designed to have the pole locations corresponding to this minimum crest factor.

The peak-to-full-wave-average ratio measurement is made by an absolute-value amplifier in an automatic gain control loop referenced to a one-volt source (Fig. 3). The resulting output voltage is digitized and averaged over five intervals to reduce variations caused by noise transients.

SPECIFICATIONS

HP Model 4940A Transmission Impairment Measuring Set

Level and Frequency

TRANSMITTER:
 FREQUENCY RANGE: 200 Hz to 3904 Hz
 FREQUENCY SETABILITY: 1 Hz
 FREQUENCY ACCURACY: ± 0.5 Hz in step mode
 MANUAL MODE: Continuously adjustable; 200 Hz to 3904 Hz
 STEP 100 Hz Mode: 204 Hz to 3904 Hz in 100 Hz increments
 AUTO STEP MODE: Continuously steps up and then back (in 100 Hz increments) from 204 Hz to 3904 Hz
 OUTPUT RANGE: -10 dBm to -40 dBm
 FREQUENCY RESPONSE: ± 0.1 dB 200 Hz to 3904 Hz
 OUTPUT LEVEL SETABILITY: 0.1 dBm
 HARMONIC AND SPIRIOUS SIGNALS: Greater than 50 dB below fundamental

RECEIVER:
 FREQUENCY RANGE: 200 Hz to 3904 Hz
 FREQUENCY RESOLUTION: 1 Hz
 FREQUENCY ACCURACY: ± 0.5 Hz
 DETECTOR: Full wave average
 LEVEL RANGE: -10 dBm to -49 dBm
 LEVEL RESOLUTION: 0.1 dBm
 LEVEL ACCURACY: ± 0.1 dBm at 1 kHz from 0 to -15 dBm
 ± 0.2 dB over full frequency and level range
 60 HZ INPUT FILTER (SWITCH SELECTABLE): 25 dB loss at 60 Hz, 4 dB loss at 180 Hz

Message Circuit Noise

TRANSMITTER: Quiet termination
RECEIVER:
 WEIGHTING FILTERS: C-Message and 3-kHz flat; switch selectable
 DETECTOR: Quasi-rms
 RANGE: -10 dBm to +100 dBm
 RESOLUTION: 1 dBm
 ACCURACY: ± 1 dB

Noise-with-Tone

TRANSMITTER:
 FREQUENCY: 1004 Hz fixed
 OUTPUT RANGE: +10 dBm to -49 dBm
 LEVEL RESOLUTION: 1 dBm
RECEIVER:
 NOTCH FILTER: 50 dB rejection from 995 Hz to 1025 Hz
 For other specifications refer to Message Circuit Noise

3 Level Impulse Noise, Hits and Dropouts

TRANSMITTER:
 FREQUENCY: 1004 Hz fixed
 OUTPUT RANGE: -10 dBm to -40 dBm
 LEVEL RESOLUTION: 1 dBm
RECEIVER:
 RECEIVED TONE LEVEL: 0 dBm to -40 dBm
 NOTCH FILTER: 50 dB rejection from 995 Hz to 1025 Hz
 COUNT INTERVAL: 5 or 15 minutes or continuous
 IMPULSE NOISE THRESHOLD RANGE: Lo: 30 dBm to 109 dBm Mid: 4 dB above Lo Hi: 8 dB above Lo, 109 dBm max
 IMPULSE NOISE THRESHOLD ACCURACY: ± 1 dB

IMPULSE NOISE COUNT RANGE: Lo: 0 to 19,999; Mid: 0 to 9,999; Hi: 0 to 1,999
 COUNT RATE: 7 counts per second maximum or channel limited, switch selectable
 GAIN HIT THRESHOLD: 2, 4, 6, and 8 dB
 PHASE HIT THRESHOLD: 10 to 45 degrees in 5 degree increments
 HIT GUARD INTERVAL: 4 ms
 DROPOUT LEVEL THRESHOLD: Fixed; greater than 12 dB decrease in level
 DROPOUT DURATION: 10 ms or greater
 PHASE HIT COUNTS: 0 to 19,999
 DROPOUT COUNTS: 0 to 9,999
 GAIN HIT COUNTS: 0 to 1,999
 DISPLAY: All six phenomena are counted simultaneously and stored. A switch selection displays either the Impulse Noise counts or the Hits and Dropout counts during or after the measurement period

Phase Jitter

TRANSMITTER:
 FREQUENCY: 1004 Hz fixed
 OUTPUT RANGE: -10 dBm to -40 dBm
 LEVEL RESOLUTION: 1 dBm
RECEIVER:
 FREQUENCY RANGE: 990 Hz to 1030 Hz
 LEVEL RANGE: -10 dBm to -40 dBm
 LEVEL RESOLUTION: 1 dBm
 JITTER DETECTOR: Peak to peak
 JITTER BANDWIDTH: 20 Hz to 300 Hz
 JITTER RANGE: 0.2 to 25 degrees
 JITTER ACCURACY: $\pm 5\%$ of reading ± 0.2 degrees
 JITTER RESOLUTION: 0.1 degree

Envelope Delay

TRANSMITTER:
 FREQUENCY RANGE: 300 to 3904 Hz
 MODULATION FREQUENCY: 83 1/3 Hz
 LEVEL RESOLUTION: 0.1 dBm
 For other specifications refer to Level/Frequency
RECEIVER:
 FREQUENCY RANGE: 300 to 3904 Hz
 LEVEL RANGE: -10 to -40 dBm
 LEVEL ACCURACY: ± 0.25 dBm
 LEVEL RESOLUTION: 0.1 dBm
 DELAY RANGE: -3,000 to +9,000 microseconds
 DELAY RESOLUTION: 1 microsecond
 DELAY ACCURACY (BACK TO BACK): $\pm 10 \mu s$ from 600 to 3904 Hz; $\pm 30 \mu s$ from 300 Hz to 600 Hz
 MINIMUM SIGNAL TO NOISE RATIO: 20 dB, 3 kHz flat weighting for stated accuracy

Noise-to-Ground

TRANSMITTER: Quiet termination
RECEIVER:
 RANGE: 40 to 130 dBm
 INPUT CIRCUIT: 600 or 900 ohms across the line; 100k ohms to ground
 For other specifications refer to Message Circuit Noise

Nonlinear Distortion (Optional)

TRANSMITTER:
 TEST SIGNAL TYPE: Two pairs of tones centered at 860 Hz and 1380 Hz

OUTPUT RANGE: 0 to -40 dBm
 LEVEL RESOLUTION: 1 dBm

RECEIVER:
 LEVEL RANGE: -10 to -35 dBm
 LEVEL ACCURACY: ± 1 dBm
 LEVEL RESOLUTION: 1 dBm
 2ND ORDER RECEIVE FILTERS: Centered at 520 and 2240 Hz
 3RD ORDER RECEIVE FILTER: Centered at 1900 Hz
 2ND ORDER PRODUCTS RANGE: to 50 dB below received level
 3RD ORDER PRODUCTS RANGE: to 60 dB below received level

P/IAR (Optional)

TRANSMITTER:
 OUTPUT RANGE: 0 to -40 dBm

LEVEL RESOLUTION: 1 dBm

RECEIVER:
 LEVEL RANGE: -10 dBm to -30 dBm

LEVEL RESOLUTION: 1 dBm

P/IAR RANGE: 0 to 120 P/IAR Units

P/IAR RESOLUTION: 1 P/IAR Units

P/IAR ACCURACY: ± 2 P/IAR Units

General

TRANSMITTER:
 IMPEDANCES: 600 ohms and 900 ohms

SF SKIP: 2450 to 2750 Hz nominal

RECEIVER:
 TERMINAL IMPEDANCES: 600 ohms and 900 ohms (switch selectable)

BRIDGING IMPEDANCE: Greater than 50k ohm

BRIDGING LOSS: Less than 0.3 dB at 1 kHz

RETURN LOSS: Greater than 40 dB

HIGH FREQUENCY PROTECTION: Greater than 60 dB attenuation above 500 kHz

MONITOR AMPLIFIER OUTPUT:
 OUTPUT RANGE: 0 to 7 volts

3DB BANDWIDTH: 200 Hz to 8000 Hz

FLATNESS: ± 1 dB from 300 Hz to 3900 Hz

OUTPUT IMPEDANCE: 5 ohms

OUTPUT CONNECTOR: 347 jack

TEST JACKS: 310 jack multiplied with 5 way binding posts for both transmitter and receiver

DC BLOCKING (with no holding): 200 volts

POWER REQUIREMENTS: 105 to 129 volts ac, 60 Hz

OPERATING TEMPERATURE: 32°F to 122°F

STORAGE TEMPERATURE: -40°F to 187°F

WARM-UP TIME FOR STATED ACCURACY: 5 minutes

TWO AUXILIARY BNC OUTPUT CONNECTORS: Accesses received frequency and phase jitter modulation signals

WEIGHT: 40 pounds approximately

PRICES IN U.S.A.:

4940A, \$7750

Option 001 adds P/IAR Measurement, add \$350.00

Option 002 adds Nonlinear Distortion Measurement, add \$750.00

Option 003 adds P/IAR and Nonlinear Distortion Measurements, add \$1100

MANUFACTURING DIVISION: DELCON DIVISION

690 E. Middlefield Road

Mountain View, California 94040 U.S.A.

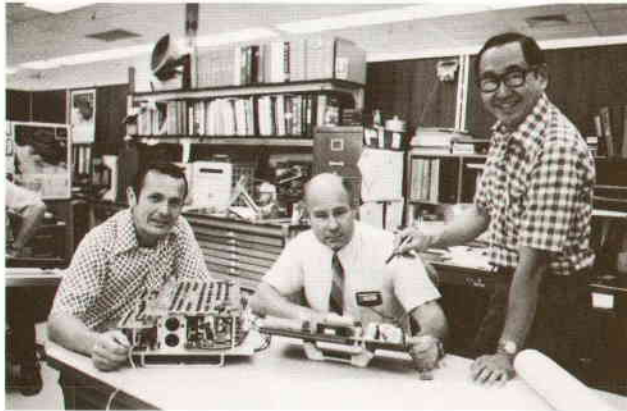

Noel E. Damon (center)

4940A project manager Noel Damon, an engineering group leader at HP's Delcon Division, has been with HP for ten years. During that time he's designed custom RF and data acquisition systems and served as project manager for ultrasonic detectors, cable fault locators, and the 4940A TIMS. Before coming to HP he designed filters and mobile telecommunications systems for seven years. Noel completed his studies for the BS degree in electrical engineering at the University of California at Los Angeles in 1957, following three years in the U.S. Army. He received his MSEE degree from Stanford University in 1970. He's married, has four children,

and lives in Sunnyvale, California, where he's active in church affairs. He likes to bowl, and for vacations, he favors fishing, hunting, skiing, and backpacking.

Donald A. Dresch (left)

Don Dresch came to HP in 1972 with eleven years' experience in the design of communications equipment and sonar systems. He implemented the nonlinear distortion measurement of the 4940A TIMS. Born in Springfield, Illinois, Don served in the U.S. Navy from 1954 to 1957, then attended the University of Illinois, receiving his BSEE degree in 1960 and his MSEE degree in 1970. He's married and has five children, and understandably finds family activities occupying a good deal of his time. But he also enjoys reading and camping, and is something of a connoisseur of malt beverages. The Dreschs live in San Jose, California.

Richard T. Lee (right)

Dick Lee has spent most of his life on the San Francisco peninsula. Born in San Mateo, he received his BSEE and MSEE degrees from Stanford University in 1958 and 1959, and was a research associate at Stanford Electronics Laboratories from 1959 to 1963. With HP since 1964, Dick has done high-frequency and VHF design for the 8411A Harmonic Frequency Converter and the 8407A Network Analyzer, and designed the transmitter section and power supply of the 4940A TIMS. He's an amateur photographer, a collector of classical music records, a Sunday school teacher, and a sometime hiker. He's married, has two children, and lives in Cupertino, California.



Erhard Ketelsen (right)

A native of Husum, Germany, Erhard Ketelsen came to the U.S.A. in 1955. During the next fifteen years he served four years in the U.S. Air Force, met and married his Swiss wife, and earned his BSEE degree from California State University, San Jose in 1970. Since joining HP in 1970, he's designed the 4910F Open Fault Locator and the P/AR circuitry and NLD transmitter for the 4940A TIMS. He's now near completion of his MSEE work at California State University, San Jose. The Ketelsens, who live in Sunnyvale, have two boys. Erhard serves as entertainment director of the local cub scout pack, and likes to spend his leisure time reading, hiking, or working on cars.

Richard G. Fowles (left center)

Dick Fowles designed the digital data processing circuits and automatic EDD referencing system of the 4940A TIMS. Dick joined HP's Delcon Division in 1970 just after graduating from California State Polytechnic University (Pomona) with

a BSEE degree. Now working for his MSEE degree at California State University, San Jose, and specializing in microprocessor design, he recently conducted a class on algorithmic state machine design for his Delcon colleagues. He's a member of IEEE and the California National Guard, and his varied interests include figure skating, archery, music, swimming, and bicycling. A native of Milwaukee, Wisconsin, Dick is single and lives in San Jose.

Johann J. Heinzl (left)

Johann Heinzl graduated from the Technical College of Moedling/Vienna, Austria in 1963 with the degree Ingenieur Grad. in telecommunications. Before coming to HP in 1972 he worked for many years in the design of television test instruments. He's a member of Fernseh Technische Gesellschaft e.V. and author of three professional papers on TV distortion measurements. Johann designed the analog envelope delay circuits for the 4940A TIMS. He is married, lives in Cupertino, California, and enjoys cross-country skiing, backpacking, and photography.

Paul G. Winninghoff (right center)

Paul Winninghoff designed the transient measurement and phase jitter circuits of the 4940A TIMS. With HP since 1964, Paul has contributed to the design of the 8552A Spectrum Analyzer IF Section, the 8443A Tracking Generator/Counter, the 4912A Fault Locator, and the 4940A. This is his third appearance in the Hewlett-Packard Journal. Paul was born in Butte, Montana. He received his BS degree in electrical engineering from Montana State University in 1962 and his MS in 1963. He's married, has two children, and lives in Sunnyvale, California. Along with his major hobbies—amateur radio and high-fidelity audio equipment—Paul has recently been studying Spanish in anticipation of a second trip with his wife to her native land, Colombia.

Microwave Integrated Circuits Solve a Transmission Problem in Educational TV

An educational TV system using a satellite transmission link needs a state-of-the-art ground-station receiver that doesn't cost very much. Microwave integrated circuits provide a way.

by James A. Hall, Douglas J. Mellor, Richard D. Pering, and Arthur Fong

THE REQUIREMENT WAS FOR A two-channel, low-noise, S-band receiver with a channel bandwidth of 20 MHz. It was to be rugged and require little if any maintenance, and it should be capable of being produced in quantity at modest cost.

Stability and low noise at a carrier frequency around 2600 MHz imply a sophistication that ordinarily has not been compatible with mass production. Microwave integrated circuits, however, can help resolve these conflicting requirements.

A novel receiver based on these requirements is designed around a microwave integrated circuit (MIC) amplifier developed at HP. This amplifier serves repetitively as a gain block at 2.6 GHz, leading to a conceptually simple design based on the tuned-radio-frequency (TRF) principle.

Basic Considerations

Today's wideband amplifiers make it unnecessary to heterodyne the received signal down to an intermediate frequency for amplification. Thus the front-end mixer and local oscillator formerly needed in microwave receivers can be dispensed with, eliminating a major source of noise and instability.

Amplification required to bring the weak antenna signal up to the +10-dBm level required by the FM video demodulator occurs at the carrier frequency in five cascaded four-stage amplifiers. The amplifiers are all based on the same MIC design using HP type 35821 transistors but with some differences in the first and last amplifiers. The first amplifier uses a selected input transistor for minimum noise and the fifth amplifier has an active biasing arrangement to increase its power-handling capability. Overall gain of the amplifier chain is about 146 dB and noise figure is less than 4.2 dB, typically 3.7 dB.

To assure that antenna cable losses (5.5 to 8.5 dB) would not affect the system noise figure, the first and second amplifiers are mounted in a separate module at the antenna. DC power to the antenna module is

supplied through the same coaxial cable that brings the RF signal back down. This allows the receiver to be placed up to 30 meters from the antenna.

Another advantage of the tuned-radio-frequency (TRF) design surfaces here: there is no need to provide for environmental immunity of the antenna module to assure the stability of a local oscillator since one isn't used. The module functions reliably throughout a temperature range from -48 to $+65^{\circ}\text{C}$.

The use of microwave integrated circuits also meets another requirement: the receiver should be capable of receiving either one of two channels, centered at 2566.7 and 2667.5 MHz. Tunability used to be a problem with TRF receivers because of insufficient bandwidth but the basic MIC amplifier has an 800-MHz bandwidth that spans both channels. In the proposed design, a single bandpass filter assembly is used for each channel. Changing channels is simply a matter of reconnecting two coaxial lines.

The Rest of the Picture

Designing a TRF receiver to operate at 2.6 GHz

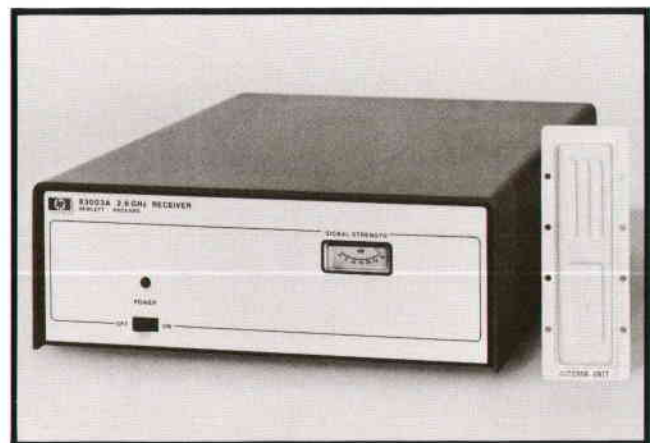

Fig. 1. Educational TV receiver converts low-level satellite-relayed signals to standard video and audio signals for direct application to a monitor.

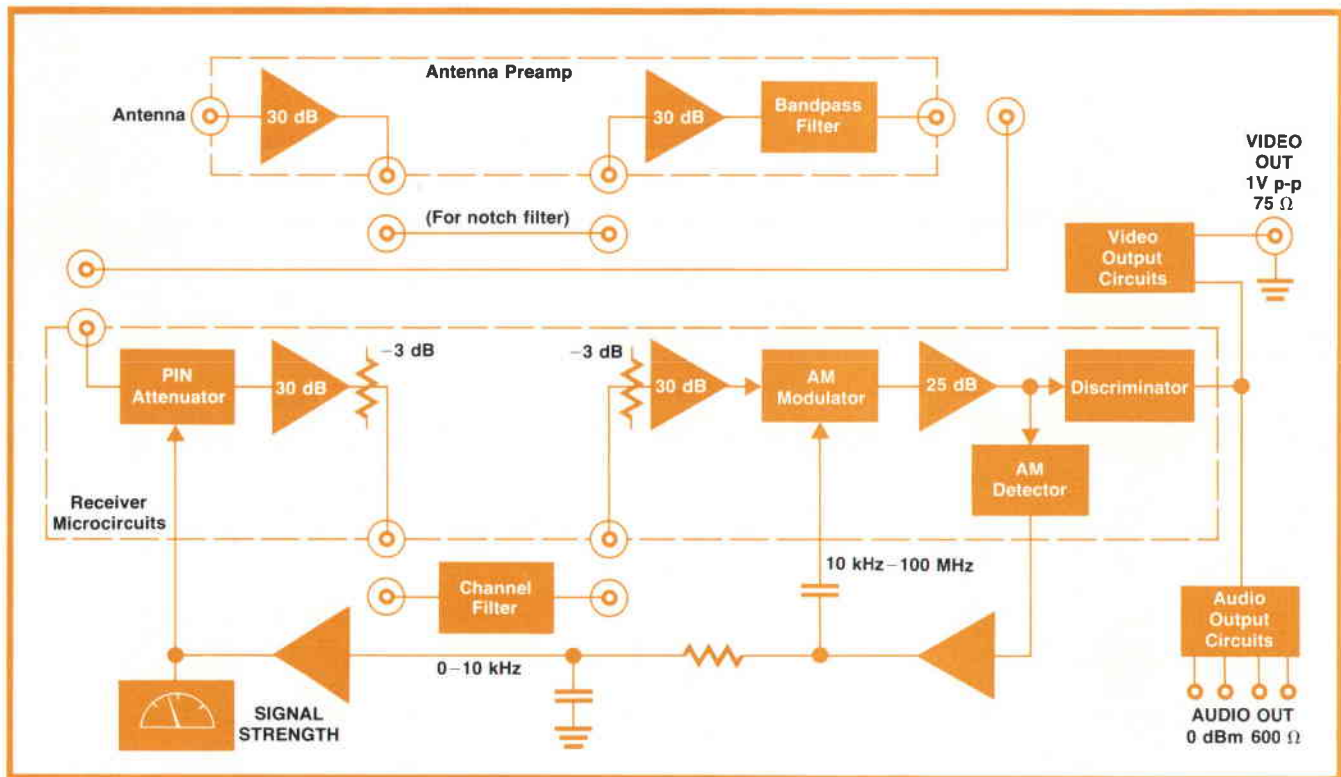

Fig. 2. Block diagram of tuned-RF TV receiver. Availability of cost-effective wideband microwave amplifiers and discriminators simplified the design.

required a few departures from traditional practice. One departure involves the limiter. The received signal consists of one video channel and four audio sub-carriers, all frequency-modulated onto the carrier. Since the receiver may be operating close to the FM threshold level, it is especially important that it not respond to variations in the amplitude of the received signal. Ordinarily, diode clippers or saturating amplifiers are used to remove amplitude variations but these don't function well at 2.6 GHz. A fast-acting ALC system is used instead.

The ALC system uses an AM detector at the side arm of a thin-film 6-dB directional coupler that follows the 5th amplifier. The detector output controls both a PIN-diode attenuator and a Schottky-diode "modulator". The PIN-diode attenuator suppresses most of the AM variations but it is effective only for variations occurring at rates below 100 kHz. The high-frequency variations are suppressed by the Schottky-diode modulator (or, if you will, "AM-unmodulator", which really describes its function).

As shown in the block diagram of Fig. 2, the PIN-diode attenuator is placed ahead of the third RF amplifier, thus reducing the dynamic range requirements of the circuits that follow. The modulator is just ahead of the fifth amplifier. Because of the short signal paths in the circuits, feedback-loop phase shift is minimized. Thus, amplitude variations occurring at rates

up to 100 MHz are suppressed.

This system provides more than 30 dB of AM suppression and it maintains the discriminator drive level within ± 0.5 dB for all normal input signal levels and operating temperature variations. Another advantage of the high-speed ALC limiting technique is that it generates no carrier harmonics as clippers do, eliminating the need for further filtering.

The Discriminator

The wavelength of a 2600-MHz signal is sufficiently short to make transmission lines 1 or 2 wavelengths long compatible with microwave integrated circuit technology. It is thus possible to design a discriminator based on the variations of a transmission line's input impedance as a function of frequency, and build it using mass-producible thin-film techniques.

To gain some insight into the operation of this kind of discriminator, Fig. 3 is presented. One transmission line (T1) is terminated in a short and the other (T2), equal in length to T1, is terminated in an open. At very low frequencies, the input to T1 is effectively shorted so no input voltage appears at node 1.

Transmission line T2, on the other hand, has a high input impedance at low frequencies so all of the input voltage appears at node 2. The output of the summing block is then a negative voltage, $-V$.

At the frequency where the lines are $\frac{1}{4}\lambda$ long, the

Direct-to-Schoolhouse Satellite Relay of Video Programs

Among the many experiments being conducted this fall by NASA's latest applications technology satellite, the ATS-6, is an ambitious experiment involving direct-to-schoolhouse relay of educational TV programs. The experiment, developed by the Federation of Rocky Mountain States, a regional educational organization, is designed to determine the feasibility of making metropolitan educational resources available to sparsely settled areas. With the satellite relay, educational programs like those for early childhood, career development, and continuing adult education can be brought to areas where resources have hardly been adequate to provide basic reading, writing and arithmetic, much less anything beyond that.

The satellite link is also being used to carry video consultations to hospitals and other health care centers that otherwise do not have ready access to major medical facilities. The system is funded by the National Aeronautics and Space Administration and the Department of Health, Education, and Welfare. Many other organizations, such as the Corporation for Public Broadcasting, are also involved in the effort.

Parked in an equatorial geo-stationary orbit 22,300 miles above the earth at 94° west longitude over the Galapagos islands, the satellite has an elliptical ground coverage over the United States of about 800 by 500 km. Pointing is ground controllable to cover any portion of the continental United States.

Pre-taped TV material with as many as four simultaneous language channels is beamed up to the ATS-6 satellite from a ground station near Denver, Colorado. Powered by solar cells, the satellite functions as a transponder, receiving signals on carrier frequencies near 2 and 6 GHz and re-radiating them to earth at S-band frequencies (2566.7 and 2667.5 MHz).

The 2600-pound satellite has a 10-meter antenna dish, the largest ever deployed in space. The parabolic dish consists of a copper-coated Dacron mesh supported by thin-gauge aluminum ribs that had been wrapped around the satellite body for the launch phase. The dish gives a beam width of 2.7° which, with the 22 watts of transmitter power, gives an effective isotropic radiated power of 200,000 W.

About 100 receiving sites are involved in the initial program. The antenna at each site is a fixed, parabolic dish 3 meters in diameter. The receiver recovers the video signal and the four audio channels for direct application to a monitor or for remodulation to VHF for CATV distribution amplifiers.

The key to the implementation of the educational TV program and other similar systems is the realization of a low-cost satellite ground station. The receiver must be reliable, simple to operate, and suitable for mass production. Nevertheless, it must give state-of-the-art performance. How technology in the form of microwave integrated circuits can resolve these conflicting requirements is described in the accompanying article.

The ATS-6 was built by Fairchild Industries, and Westinghouse Electric Corporation is prime contractor for the ground station. Hewlett-Packard developed a suitable receiver with company resources and produced a quantity under sub-contract for the experiment (the receiver is not offered for individual sale).

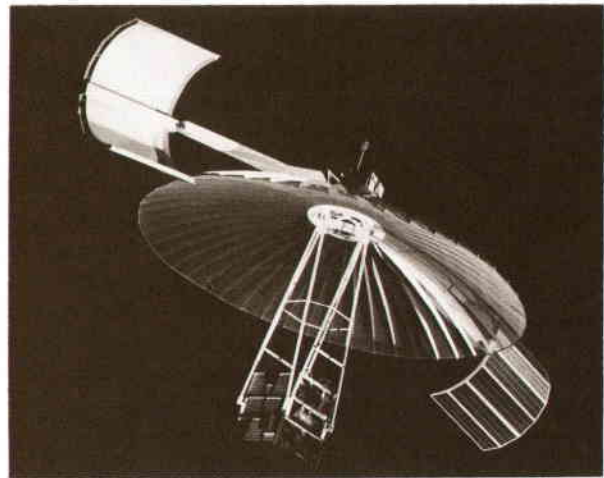

situation is reversed. Now line T2 appears as a short at node 2, while the input to T1 appears as an open circuit. The output of the summing block is now a positive voltage, +V.

At a signal frequency where the lines are $\frac{1}{8}\lambda$ long, the magnitudes of the transmission lines' input reactances are equal, so the diode detectors produce equal but opposite voltages. The output of the summing block is then zero. Since the voltage output varies relatively linearly with respect to input frequency, this network could be used as an FM discriminator by making the lines $\frac{1}{8}\lambda$ long at the carrier frequency.

Above the frequency where the lines are $\frac{1}{4}\lambda$ long, the voltage output reverses sense, returning to $-V$ at the frequency where the lines are $\frac{1}{2}\lambda$ long, where it again reverses sense. This process repeats as the frequency increases, with the output passing through zero when the lines are odd multiples of $\frac{1}{8}\lambda$ long. This suggests that the sensitivity (volts/MHz) can be

increased by making the lines an odd multiple of $\frac{1}{8}\lambda$.

The final discriminator design uses lines about $13/8\lambda$ long at 2600 MHz. The output thus goes from $-V$ to $+V$ between 2400 and 2800 MHz, thus increasing sensitivity by a factor of 13 but still allowing enough bandwidth to accommodate both channels.

Sensitivity and linearity were further improved through use of a computer optimization program that modified the transmission-line characteristic impedance and lengths. As a result, 70Ω transmission lines are used and the resultant voltage/frequency triangle is asymmetrical.

One serious problem with this type of discriminator has been the response to harmonics. In the final discriminator design, these were reduced to manageable proportions by inserting resistances in the lines $\frac{1}{4}\lambda$ from the terminating ends. At the center frequency, a shunt resistor at this position in the open line is at a voltage null and therefore has no effect on circuit operation. At all even harmonic frequencies,

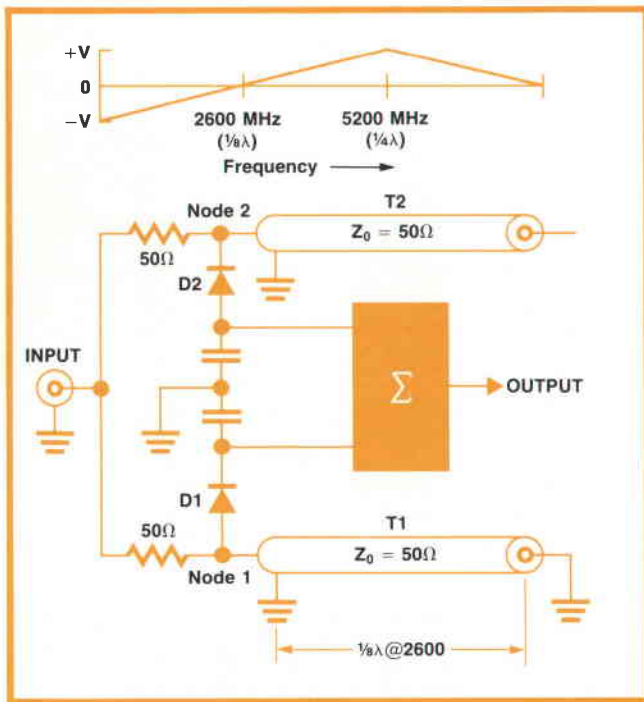

Fig. 3. Basic transmission-line FM discriminator.

however, it is at a high impedance point so it terminates the line. A series resistor performs a dual function in the shorted line.

All of the circuits beyond the discriminator use standard off-the-shelf components and conventional techniques. The output of the discriminator is amplified an additional 30 dB for application to the TV de-emphasis network and to the four audio subcarrier demodulators.

The video signal is further amplified and then applied to a diode dc restoration circuit. This removes a 30-Hz triangular modulation (synced to the video frame rate) that is frequency modulated onto the satellite down-link carrier to disperse the energy within the frequency spectrum. This technique is needed to meet international maximum flux density specifications designed to protect terrestrial communications systems from satellite interference.

RF Filtering

Preliminary filtering is provided in the antenna

module by a 3-section thin-film filter that has a bandwidth of 300 MHz at the 3-dB points and less than 1-dB insertion loss. This filter is a capacity-coupled, $\frac{1}{2}\lambda$ transmission-line design.

Connectors are provided in the antenna module for inserting an optional notch filter between the two amplifiers. This is for use in areas where there may be strong interference from adjacent RF signals.

Center frequency, receiver bandwidth, and group delay characteristics are determined by the channel filter, so this filter is critical to proper receiver operation. Because of the requirements for high Q, thin-film circuits could not be used here (in general, the smaller a resonant structure is, the lower the Q). The proportionately narrow bandwidth (0.9%) and the need for temperature stability dictated a coaxial 3-pole interdigital structure. This gives a bandwidth of 23.5 MHz at the 3-dB points. Temperature-compensated resonators assure a frequency drift of less than 2 ppm/°C.

RF Amplifier

As mentioned before, the RF amplifier is a key factor in determining receiver cost and performance. It must be designed in a way that takes maximum advantage of the high gain-bandwidth product available from present-day microwave transistor chips but it must be simple to fabricate and test.

The two-element (shunt L, series C) matching networks often used as transistor interstages yielded a 300-400 MHz bandwidth in this application. However, to assure adequate gain flatness within the bandwidth of interest and to allow for the inevitable variations from unit to unit without resorting to trimming adjustment, bandwidth was doubled with little sacrifice in gain or complexity by using the double-tuned interstage shown in Fig. 4.

First of all, for maximum bandwidth L_c is made equal to zero. This requires a coupling coefficient K such that:

$$K = (R_2/R_1)^{1/4}$$

Then, $C_2 = C_1/K^2(1-K^2)$, where C_1 is the parasitic capacitance.

Relationships established by the center frequency are

$$L_1 = 1/(\omega_0^2 C_1) \text{ and } L_2 = K^2 L_1.$$

These values were transformed to those required for

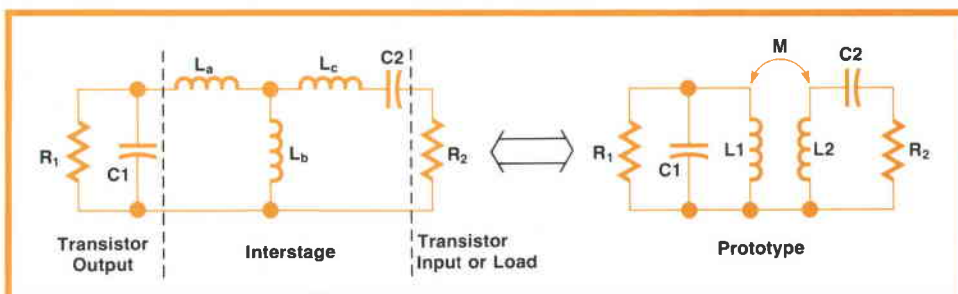



Fig. 4. Interstage coupling circuit at left was derived from the transformer-coupled prototype at right. Four-stage hybrid amplifiers using microwave chip transistors and this interstage achieve 30 dB of gain and 600-800 MHz bandwidth at 2.6 GHz.

the actual circuit by the following relationships:

$L_c = L_2 - M$ where M , the mutual inductance, $= K\sqrt{L_1L_2}$ (it was already established that $L_c = 0$); $L_b = M$; and $L_a = L_1 - M$.

A four-stage amplifier design using this interstage was realized in thin-film circuitry by making L_b a shorted shunt section of transmission line and L_a a squared spiral inductor. C_2 is a chip capacitor.

Acknowledgments

Thanks are due R. Ruppel for the product design, H. Halverson and D. Gray for their early work, and the many people of the Microelectronics Technology Center. Also involved in formulating the basic concept were A. Whelan of NASA, J. Janky of the Rocky Mountain Federation, and A. L. Horley of HEW. 



Douglas J. Mellor (far left)

Doug Mellor joined HP in 1971 on graduating from Brigham Young University with BSEE and MSEE degrees. Initially he worked on the 1.3 GHz plug-in for the 8660A Synthesized Signal Generator and then went to work on the 2.6 GHz amplifier for the TV receiver. Meanwhile he completed course work towards a PhD in the HP Honors Co-op program and now plans to tackle the dissertation. Active in church affairs, he also likes to picnic with his family (two girls, 4 and 3, and a boy, 1) and do a little hunting and fishing on his own.

Richard D. Pering (far right)

Rick Pering worked summers at HP starting in 1958 and he joined full-time in 1962 after graduating from Stanford University (BSEE). Initially he worked on frequency-counter plug-

ins for the 5245-series Counters and later became project leader on the 8-18 GHz Frequency Converter plug-in. Following that, he worked on high-frequency integrated-circuit transistor arrays and then worked on the filters and MIC discriminator in the TV receiver. With two children ages 3 and 5, Rick and his wife devote what spare time they have to working with the Creative Initiative Foundation, an organization devoted to developing human potential.

James A. Hall (left center)

A native of Halifax, Virginia, Jim Hall worked 13 years in microwave communications before joining HP in 1972 to work on planning for the TV receiver. He has a BSEE from North Carolina State University and an MS in Physics from Lynchburg College (Va.). Besides being an amateur radio operator (CW), Jim's also an amateur mineralogist (rock hound), gardener, and flyer. He and his wife have two children, 7 and 4.

Arthur Fong (right center)

Of Art Fong's many accomplishments, he is best known for his contributions to HP microwave signal generators and spectrum analyzers but he also laid the groundwork leading to HP's involvement in hybrid microcircuits. He's a graduate of the University of California (BSEE) and Stanford (MSEE). Art was concerned with microwave test instrumentation at the MIT Radiation Labs during World War II. Since joining HP in 1946, he has had a number of positions, but he is now on the HP corporate engineering staff, responsible for electronic design strategy. An avid skier, Art also likes fishing, backpacking, and photography—activities he finds more time for now that the two youngest of his four children are in college.

Hewlett-Packard Company, 1501 Page Mill Road, Palo Alto, California 94304

HEWLETT-PACKARD JOURNAL

AUGUST 1974 Volume 25 • Number 12

Technical Information from the Laboratories of
Hewlett-Packard Company

Hewlett-Packard S.A., CH-1217 Meyrin 2
Geneva, Switzerland

Yokogawa-Hewlett-Packard Ltd., Shibuya-Ku
Tokyo 151 Japan

Editorial Director • Howard L. Roberts
Managing Editor • Richard P. Dolan
Contributing Editors • Ross H. Snyder,
Laurence D. Shergalis

Art Director, Photographer • Arvid A. Danielson
Art Assistant • Sue M. Reinheimer
Administrative Services • Anne S. LoPresti
European Production Manager • Kurt Hungerbühler

Bulk Rate
U.S. Postage
Paid
Hewlett-Packard
Company

CHANGE OF ADDRESS . To change your address or delete your name from our mailing list please send us your old address label (it peels off). Send changes to Hewlett-Packard Journal, 1501 Page Mill Road, Palo Alto, California 94304 U.S.A. Allow 60 days.

HP Archive

This vintage Hewlett-Packard document was
preserved and distributed by

www.hparchive.com

Please visit us on the web!

On-line curator: John Miles, KE5FX

jmiles@pop.net

