

APRIL 1974

HEWLETT-PACKARD JOURNAL



Mass Memory System Broadens Calculator Applications

Inventory control, payroll, order processing, and other large-data-base applications are now within the capability of HP's most powerful desktop calculator, the BASIC-language Model 30.

by Havyn E. Bradley and Chris J. Christopher

MODEL 30 OF HEWLETT-PACKARD'S 9800 Series Calculators, or Model 9830A if you prefer, ranks among the world's most powerful desktop calculators.¹ Its BASIC-language programming, along with alphanumeric string and matrix manipulation, give it tremendous data handling capability. As a result, many users have developed applications that require storage capacity much larger than Model 30's standard tape cassette can provide. Typically, these applications also call for random data access, and therefore are not conveniently run on any magnetic tape system. Such applications include inventory control, payroll processing, order processing, account maintenance and others.

The most obvious answer is a disc drive, and two are now available as peripherals to the 9830A. The drives are Hewlett-Packard 7900 Series Disc Drives² that have been slightly modified and given new model numbers. Model 9867A has one removable disc cartridge. Model 9867B has one fixed disc and one removable cartridge. Each fixed disc or cartridge can store 2.4 million 8-bit bytes of data. Data access is rapid and, most important, the drives have proven high data-handling reliability.³

On the assumption that a calculator-based system should have a command set that is flexible and powerful, yet easy to use, the FILES commands of HP 2000C time-shared BASIC were implemented for the new system. This means that users can take advantage of the large library of programs for HP 2000 Time-Shared Computer Systems. Only minor modifications are needed to run these programs on the new calculator-based system.

Included with the new system is a comprehensive package of support software to simplify system turn-on and data backup. Close cooperation between hardware and software development teams was maintained to arrive at a reliable and versatile system at

minimum cost, and to make the hardware as unobtrusive to the user as possible.

Mass Memory System

Besides the disc drive, the new mass memory system includes the elements shown in Fig. 1. A plug-in read-only memory (ROM) block is installed in one of the 9830's eight ROM slots to expand the calculator's instruction repertoire. An interface cable assembly containing interface circuitry and a small cache



Cover: *There was a time when a small business only needed one good book-keeper. Today he usually has a staff and, more and more frequently, an automatic data processing system. A particularly painless way for a small business to get started in automated accounting, inventory control, and other large-data-base applications is the new 9880A/B Mass Memory System for the 9830A Calculator.*

In this Issue:

- Mass Memory System Broadens Calculator Applications, by Havyn E. Bradley and Chris J. Christopher . . .* **page 2**
- An Easily Calibrated, Versatile Platinum Resistance Thermometer, by Tony E. Foster* **page 13**
- Speeding the Complex Calculations Required for Assessing Left Ventricular Function of the Heart, by Peter Dikeman and Chi-ning Liu* **page 18**

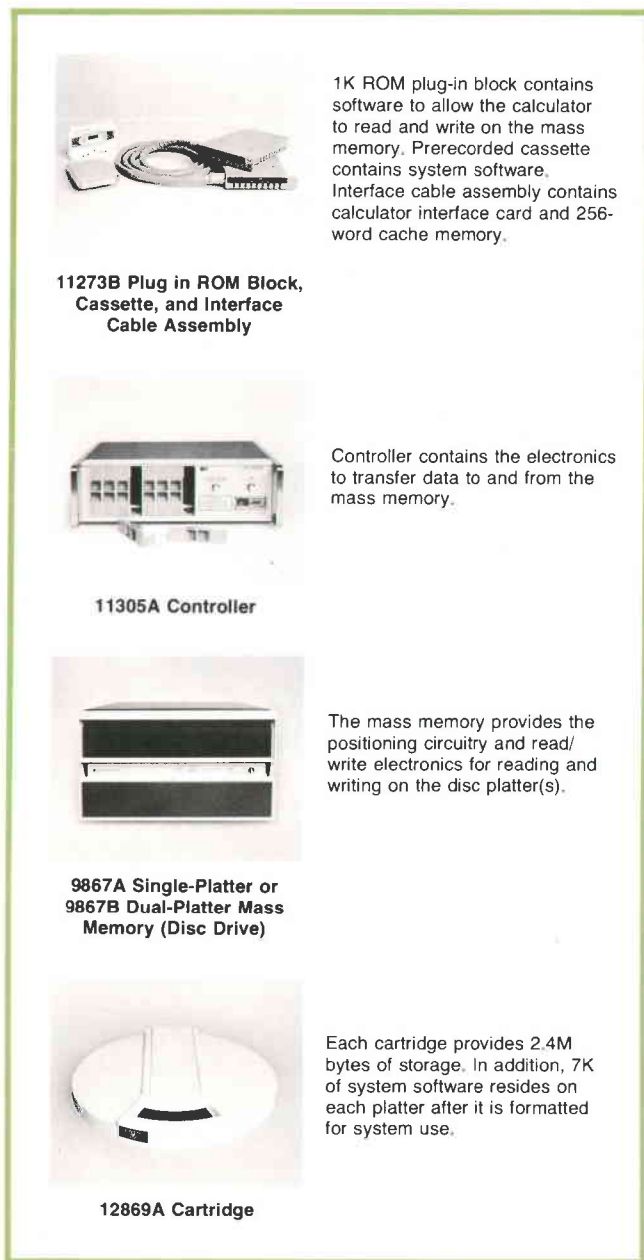

1K ROM plug-in block contains software to allow the calculator to read and write on the mass memory. Pre-recorded cassette contains system software. Interface cable assembly contains calculator interface card and 256-word cache memory.

11273B Plug in ROM Block, Cassette, and Interface Cable Assembly

Controller contains the electronics to transfer data to and from the mass memory.

11305A Controller

The mass memory provides the positioning circuitry and read/write electronics for reading and writing on the disc platter(s).

9867A Single-Platter or 9867B Dual-Platter Mass Memory (Disc Drive)

Each cartridge provides 2.4M bytes of storage. In addition, 7K of system software resides on each platter after it is formatted for system use.

12869A Cartridge

Fig. 1. Model 9880A/B Mass Memory System for Model 9830A BASIC-Language Calculator consists of the elements shown here. The FILES commands of HP 2000C time-shared BASIC are used to access the mass memory; advantages are ease of use and a large existing program library.

memory connects the calculator to the disc drive controller. Another cable assembly connects the controller and the disc drive.

The complete system is designated Model 9880 Mass Memory System. Model 9880A includes the 9867A Mass Memory (disc drive) and Model 9880B includes the 9867B.

Fig. 2 shows the information-transfer paths in the system. All data transfers between the calculator and the mass memory go through the cache memory. All

addresses, commands, and status information are processed through the 9830A input/output structure.⁴ The basic difference is that cache-memory transfers go directly to the calculator read/write memory and are much faster than transfers through the calculator I/O structure.

The cache memory is a 256-word (512-byte) MOS read/write memory. It allows data transfer from the calculator at one rate and to the mass memory at a different rate. This avoids any synchronization or timing problems between the two components. The full 256-word contents of the cache memory are transferred during any read/write operation with the mass memory. The cache memory appears to the calculator as an extension of its own memory, but it is not accessible by the user.

Multiple Calculators and Platters

The mass memory has an extremely large storage capacity. Each disc, or platter, as it is frequently called, can store 2.4 million bytes. Therefore, one mass memory is usually enough for an individual user.

For applications that require still more storage, the 11305A Controller can handle up to four platters in the same system, giving a total storage capacity of 9.6 million bytes. This offers some important advantages to the user. For example, he can access separate data bases stored on different cartridges and process the data on another platter. It also makes duplication of important data bases very simple.

To match this storage and accessing capacity, the controller can also handle up to four 9830A Calculators in the same system (see Fig. 3). Any of the four calculators can access any of the four platters connected to the system. Each platter contains the full system software and is not dependent on any of the others for its operation.

It should be emphasized that this system is *not a time-shared system in the usual sense*. Only one calculator can access a platter at any given time. The remaining calculators in the system can access their respective cache memories during this time. The cache memory remains dedicated to the calculator, not to the controller.

It is true, however, that two or more users can be working on different applications and sharing one or more mass memories, and in most such situations, neither user would notice that someone else was using the system. An order processing system, for example, might have someone entering new orders, another preparing shipping papers and updating inventory records, and still another preparing order acknowledgments and billing customers. The new order entries could be transferred from a holding file to the main data base at the beginning of each day.

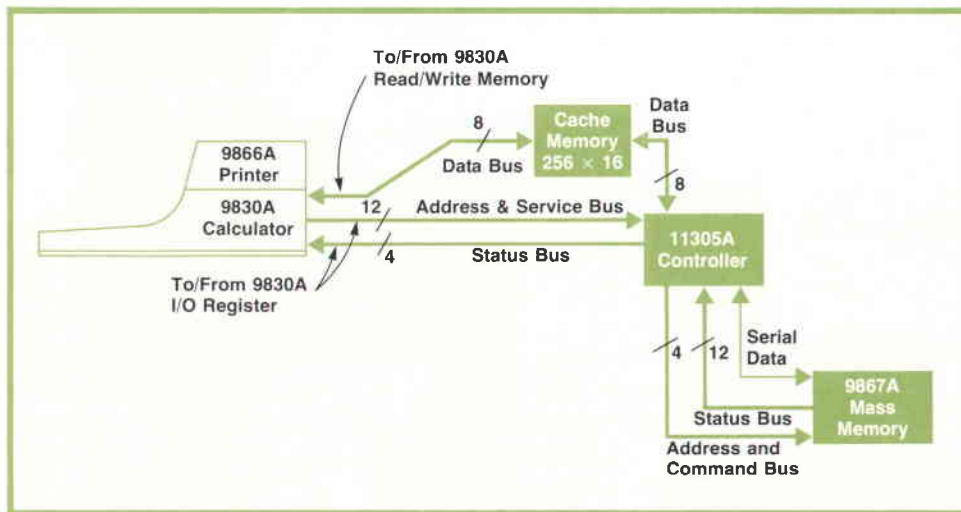

Fig. 2. Data transfers to and from the mass memory (disc drive) go by way of a cache memory that is separate from the calculator I/O system and considerably faster.

Software Organization

The 9830A add-on ROM structure allows the user to select specific ROM blocks to integrate a system that meets his needs.¹ The maximum number of add-on ROMs is eight. Each contains 1024 words. The total software necessary to meet the objectives of the mass memory system was estimated at approximately 7000 words. Obviously, it would be impractical to

provide all this software as firmware because this would consume most of the add-on ROM capability of the calculator. This problem was solved by adapting the software organization shown in Fig. 4.

The single 1K Mass Memory ROM provides the controlling firmware and all the speed-sensitive mass memory commands. Additional mass memory commands that are to be executed from the keyboard or infrequently in a program are stored on each mass memory platter during initial turn-on. When these commands are encountered in a program or executed from the keyboard, the mass memory ROM fetches the corresponding bootstrap—i.e., software needed to accomplish the particular function—from the mass memory, transfers it to the calculator read/write memory (RWM), and executes it. A bootstrap fetch operation is accomplished within 50 milliseconds.

How are the bootstraps executed in the RWM of the calculator without destroying the user information currently residing there? During power turn-on, if the mass memory ROM block is present, the calculator allocates 300 words of RWM for mass memory operations. The 300 words are used for bootstrap execution and special mass memory buffers that facilitate the execution of the data transfer commands.

The support software is comprised of a number of binary programs stored on a magnetic tape cassette that every mass memory user will receive. These programs accomplish such functions as initial system turn-on, bootstrap verification, platter duplication, repack of mass memory files, and so on.

Platter Organization

Each platter, removable or fixed, represents a separate mass memory system. As such, each platter is independent and must have its own directory area, bootstraps, and so on. The platter organization is as follows.

Mass Memory for Business Applications

To help users put the new Mass Memory System to work as soon as it's installed, three applications program packages are now available. They are for inventory control, accounts payable, and accounts receivable.

In each package are all the programs a typical user needs for each type of application. Thus the programming effort required of the user is greatly reduced. While some users may elect to modify the programs, for example, by changing the format of a report, many will find the programs usable as is.

The Accounts Receivable and Billing package provides for orderly follow-up of receivables and fast preparation of statements. Statements and reports are generated at a single keystroke. The system can be operated by any clerk who understands accounts receivable—no computer expertise or special training are needed.

The Inventory Control package provides reports to help management make inventory decisions. Complete reports, such as status, activity, and reorder, are called for by a single keystroke. This package also provides for immediate inquiry into the status of any item in the inventory.

The Accounts Payable package features easy operation by normal office staff. It provides management reports to help anticipate future cash requirements, the ability to reflect discounts when available, and check writing capability. It can charge payments to various general ledger accounts and cost centers, and it can handle partial payments to invoices for balancing available cash with cash requirements.

All of the packages are designed for ease of operation, easy data entry, and expandability.

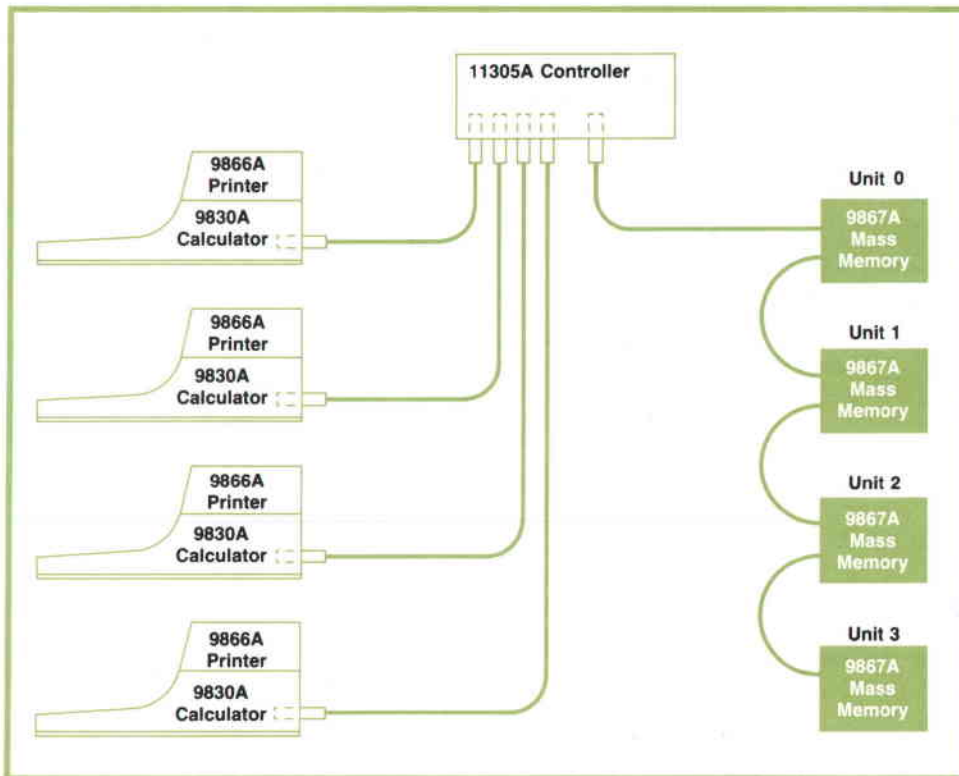

Fig. 3. Controller can handle up to four platters and four calculators. Operation is not time-shared: only one calculator at a time can access a mass memory. At least two platters are recommended so backup copies of data can be made easily.

Any location on the platter is defined by three variables: head, cylinder, and sector.⁶ CYLINDER defines the radial position. There are 203 cylinders, 0 through 202, numbered from the outside of the platter towards the center. SECTOR defines the angular position around the platter. There are 24 sectors, numbered 0 through 23. A thin metal skirt on the hub of the platter has 24 slots cut into it to define precisely the start of each sector. An index slot provides a reference for sector 0. HEAD 0 and HEAD 1 specify the upper and lower platter surfaces, respectively.

Each platter is divided into two areas, the system area and the user area. The system area is used by the mass memory system and is occupied by the following items.

Item	Location
Directory	Head 0, Cylinders 0 and 1
Availability Table and Defective Track Table	Head 0, Cylinder 2
Bootstraps	Head 0, Cylinders 3 to 7

The directory serves as the file index of the mass memory system. All file names, along with other pertinent information such as relative location and size, are entered in the directory. The availability table contains a list of all vacant mass memory segments that are available for user files. The directory and the availability table are automatically updated by the system every time a file is created or deleted. The defective track table contains a list of the defective tracks present on the platter. A maximum of six defective tracks are allowed in the user area.

The remaining platter area is available for user data, program files, and key files. This area has a capacity of 4752 512-byte records.

Files

The mass memory system accepts three types of files: data, program, and key files. The minimum file size is one 512-byte record. The maximum file size is 4752 records.

Data files are created via the OPEN command. This command is both keyboard-executable and programmable, and has the following syntax:

```
[Line No.] OPEN "DATA1", N
[Line No.] OPEN A$, N
```

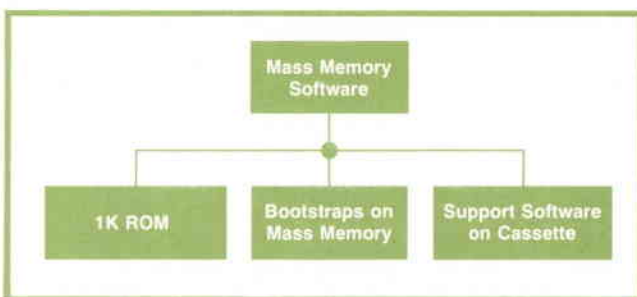

Fig. 4. Mass memory software organization. Control firmware and speed-sensitive mass memory commands are stored in the read-only memory. A prerecorded support cassette is used to record bootstraps (routines to execute other mass memory commands) on the platter when the system is turned on.

N specifies the length of the file in records, DATA1 is a file name, and A\$ is a string variable that represents a file name to be assigned later. The line numbers are used only when the OPEN command is in a BASIC-language program.

Data files can be deleted via the KILL command.

```
[Line No.] KILL "DATA1"
```

```
[Line No.] KILL A$
```

Like OPEN, the KILL command is both program-able and keyboard-executable. Thus a program can determine the necessary number of data files and their sizes, create these files, and dynamically delete them when their contents are no longer needed.

Program and key files are automatically created by the SAVE and SAVEKEY commands, which store in the mass memory the present main-line programs and key definitions, respectively. The system calculates the minimum file size, opens the file, and stores the specified information. Programs can be read from the mass memory and transferred to the calculator via the GET and CHAIN commands. The GET command destroys the variable values established by any previously executed program whereas CHAIN retains them. Like data files, program and key files can be deleted via the KILL command.

Data Handling

The mass memory system enhances the data handling capacity of a 9830A Calculator. Numeric data in integer form (± 32767), split precision form ($\pm 9.99999E+63$), and full precision form ($\pm 9.99999999999E+99$) can be stored in mass memory files. Integers and split precision numbers occupy four mass memory bytes. Each full precision number occupies eight mass memory bytes. When numeric data is retrieved from the mass memory, type conversion is allowed and is automatically accomplished by the mass memory system, provided that numeric overflow is not encountered.

If a String ROM block is present in the 9830A, alphanumeric strings of characters can also be stored

in the mass memory. The maximum string size is 255 characters. Strings and numeric items of any precision can be stored in mass memory files in any order.

Data can be stored in mass memory files in serial or random modes. In the serial case, the complete file is considered a serial access storage device. In the random case, a file can be used as a random access storage device in which logical records (256-word sub-files) can be modified independently.

The data files that will be accessed by a given program must be declared by name in a FILES statement before data storage or retrieval is attempted. A maximum number of ten files can be declared in a FILES statement and be active at any one time.

Upon execution of the FILES statement, it will be verified that the declared files exist in the directory as data files. In addition, the "files" buffer will be created. This buffer will contain address, size, and other file information. Once this buffer is created, all subsequent data transfer commands will refer to the declared files by numbers corresponding to their relative positions in the FILES statement. This technique allows greater flexibility and higher data transfer rates.

Data is stored in the mass memory via the PRINT # command and retrieved via the READ # command. Entire arrays can be transferred to and from the mass memory via the MAT PRINT # and MAT READ # commands when a Matrix ROM block is available in the system.

The PRINT #n; END command prints an "end of file" marker in the next available position of the nth data file, where $n = 1, 2, 3, 4, 5, 6, 7, 8, 9, 10$. This marker indicates the end of available data and can be detected by the READ # commands.

The TYP(n) function can be used effectively to determine the type of the next data item in a data file, and thus avoid terminal execution errors caused by type mismatch. The value of the function is an integer between 0 and 6, depending on whether the next item is a full-precision number, a string, an end-

```
10 REM THIS PROGRAM ALLOWS THE USER TO ENTER SALES INFORMATION.
20 REM THE INPUT INFORMATION (CUSTOMER NAME AND ADDRESS, NO. OF UNITS PURCHASED
30 REM AND TOTAL COST OF TRANSACTION) IS STORED IN THE DATA FILE "PORDER".
40 FILES PORDER,TEMP,*,*
50 DIM A$(70),B(2),D$(10)
60 PRINT
70 PRINT "CUSTOMER'S NAME ?"
80 INPUT A$(1;20)
90 PRINT "CUSTOMER'S ADDRESS ?"
100 INPUT A$(21;70)
110 PRINT "NO. OF UNITS ?"
120 INPUT B(1)
130 PRINT "UNIT COST ?"
140 INPUT C
150 PRINT "DONE ?"
160 INPUT D$
170 PRINT #1:A$,B(1),C*B(1)
180 IF D$="NO" THEN 60
190 PRINT #1:END
200 END
```

Fig. 5. Up to ten files can be active at any time. Files must be named in a FILES statement (line 40). *s may be used to reserve storage for files to be assigned later.

```

10 REM THIS PROGRAM PRINTS THE SALES INFORMATION
20 REM PRESENT IN THE REQUESTED DATA FILE.
30 DIM A$(16),B$(70)
40 PRINT
50 PRINT "FILE NAME ?"
60 INPUT A$
70 FILES *
80 ASSIGN A$,1,R
90 IF R=0 THEN 130
100 PRINT "ERROR--";A$,"NOT PRESENT"
110 STOP
120 IF END#1 THEN 190
130 PRINT
140 FIXED 2
150 READ #1:B$,Y:X
160 PRINT " ";X:B$
170 PRINT
180 GOTO 150
190 END

```

Fig. 6. This program is written so it accepts a file name to be supplied by the user during execution. Data in the selected file is then printed. Line 120 ends the program when the end of the selected file is reached.

of-file marker, an end-of-record marker, a split-precision number, or an integer.

The example in Fig. 5 illustrates the file and serial data print concepts by collecting the input data and storing it serially in file "PORDER". The PRINT # command of line 170 will store the data items listed to the right of the semicolon in the file corresponding to position one of the FILES statement, that is, the file PORDER. The PRINT # command of line 190 will place an "end of file" marker in the first location of the next available record. The *'s are used in the FILES statement to reserve buffer storage for files that will be assigned later.

File Protection

To provide restricted access to important data files and to protect files from accidental deletion, the user may protect his files via the PROTECT command:

```
PROTECT "FILE NAME", "PROTECTION KEY"
```

The protection key should be a secret string of one to six characters.

The only way the user can gain access to a particular protected data file is through the ASSIGN command:

```
ASSIGN "FILE NAME", N, X, "PROTECTION KEY"
```

N is the FILES statement position to which the specified file is to be assigned. X is a return variable that provides status information about the attempted operation. The file name and protection key may also be given as string variables.

To delete protected data, program, or key files, the user must execute the KILL command augmented by the correct protection key:

```
KILL "FILE NAME", "PROTECTION KEY"
```

The example in Fig. 6 illustrates the file assignment and serial data read concepts. The IF END # command of line 120 sets an "escape" condition for the read

command of line 150. This escape condition stipulates that if an "end of file" marker is encountered in the read process, control must be transferred to line 190.

Special Commands

A set of special commands provides additional flexibility for data backup and file handling.

PLATTER-DUPLICATE transfers all the information of the specified source platter to the specified destination platter. Thus, where multiple platters are available, a backup copy of a platter's contents can be made in approximately three minutes.

DFDUMP enables the user to dump data file information onto a magnetic tape cassette. The system will dump 150 records of data on one magnetic tape cassette. If the data file is larger than 150 records and more data is present in the file, the system will request additional cassettes.

DCOPY copies the information of a specified data file into another file of a different name. The source and destination files must be of the same protective status.

DREN allows the user to change the name of a specified file. If the file is protected, the correct protection key must be given. If the proposed new name already exists in the mass memory directory, the command will be aborted.

Transfer Rates

Transfer rates for programs and data are of particular interest when the mass memory is used to GET or CHAIN many programs and transfer large amounts of

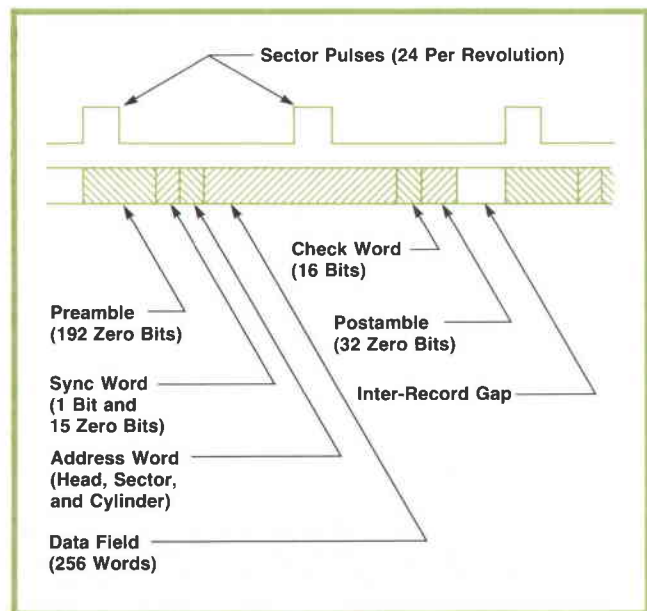

Fig. 7. Each 512-byte (256-word) record occupies two sectors on the platter.

data. The program transfer rate is approximately 1.2 milliseconds per word. Data transfer rates depend on the number of items present on the PRINT # or READ # list. The typical transfer rate is approximately 20 milliseconds per data item.

Record Format

A record is defined as the amount of information that is transferred to and from the mass memory in any given read or write operation. A record contains 256 words or 512 bytes of usable data. It also contains a preamble of 192 zero bits (see Fig. 7), a sync word, which is a 1 bit followed by 15 zeros, and an address word, which contains the binary equivalent of the three location variables (head, sector, and cylinder), followed by the data field of 256 words, the 16 bit checksum, and a postamble of 32 zero bits.

Each record occupies two sectors and begins only on the even numbered sectors. No address word exists for any odd numbered sector because this location is overwritten by the data field.

When information is written on the platter, a crystal controlled circuit provides a clock rate of 2.5 MHz. A clock pulse is written at the beginning of each data "cell." The data is mixed with this clock such that a 1 bit causes a pulse to occur between clock pulses, while a zero bit does not cause a pulse between clock pulses.⁵ When the information is read from the platter, the presence of a pulse between clock pulses indicates a 1 bit; otherwise the cell contains a zero bit.

Small variations in the speed of the platter cause the data transfer rate to fluctuate. Pulse crowding in the magnetic medium causes further perturbations in the transfer rate. When reading, therefore, it is necessary to synchronize with the data rate rather than any absolute reference. This synchronization is started at the beginning of each record. The 192 bits of the preamble allow a phase locked loop to synchronize to the 2.5 MHz data rate from the platter. Once it is locked, the loop will track the small variations in the data rate. The absence of any 1 bits in the pream-

ble assures that the loop becomes locked only to the clock rate. The 1 bit of the sync word establishes a reference point so the remainder of the record can be correctly interpreted.

The checksum is a 16-bit word that is uniquely determined by the address word and the data field. It enables certain errors to be detected when the record is read from the platter. The postamble provides clock pulses at the end of the record to allow the read circuitry to complete the read operation.

The entire record must be written each time any portion of the data field is to be changed. However, the address word will always be the same because it corresponds to the physical location on the platter.

Write Operations

A WRITE operation consists of four stages. First, the data to be written is placed in the cache memory. Next the desired platter location is found. Third, the location is verified to be the correct one, and finally, the record is written on the platter.

After the data has been placed in cache memory the calculator requests service from the 11305A controller. When service is granted to the calculator, the head, sector, and cylinder addresses are transmitted to the controller and mass memory. When the mass memory signals the controller that it has found the desired location, the controller commands the mass memory to read the address portion of that record. The address word that is read must compare bit for bit with the address sent by the calculator. If it does not, an error signal is returned to the calculator.

If the address is correct, the data is then written into the next sequential record on the platter (see Fig. 8). This offset allows time for the address comparison to be made and then a full record to be written, including the preamble and an updated address, as soon as the next record is reached. If this were not done, the controller would have to wait a full revolution of the platter before it could initiate the write command.

The read operation is the same except that the data

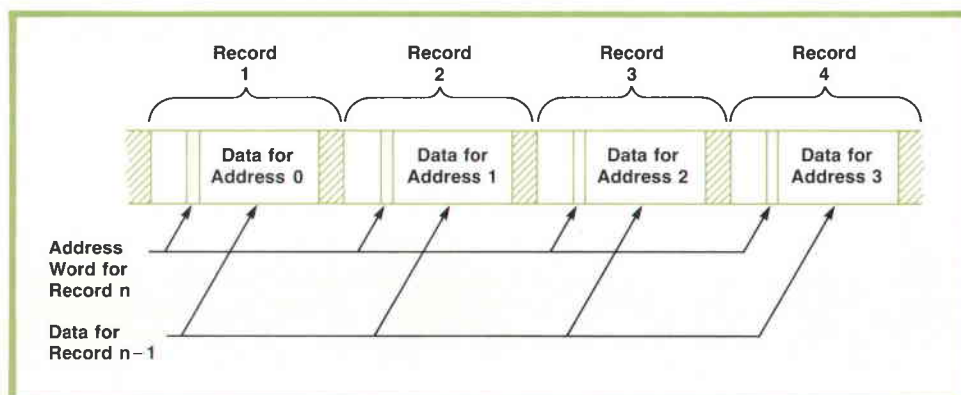

Fig. 8. Data is offset from record addresses on the platter so data can be read or written as soon as the correct address is detected instead of waiting for another revolution of the platter.

is read into cache memory from the platter. The calculator can then access any of the 256 words of cache memory as needed.

The system does not have read-after-write capability. The penalty in operating speed and software made this function costly to implement. The overall system reliability is high enough that read-after-write is not necessary.³

Multiple Platters

When there are two or more platters in a system the UNIT numbers shown in Fig. 3 provide platter identification for the system software. The 9867A single-platter drive has a switch on the front panel that can be set to four positions, 0 through 3. The 9867B two-platter drive has an internal setting corresponding to UNITS 0 and 1 or UNITS 2 and 3. In the 9867B, UNITS 0 and 2 correspond to the removeable cartridge and UNITS 1 and 3 to the fixed platter of the mass memory.

A UNIT *n* command from the calculator determines which platter in the system is to be accessed. Obviously, no two platters in the system can be assigned the same UNIT number. The UNIT number is part of the address that is sent to the mass memory. Only the drive with the selected UNIT number will respond to the controller commands.

Service Allocation for Multiple Calculators

When there are two or more calculators in a system the controller sequentially scans each of the service request lines from the calculators. As soon as a service request is detected, the controller halts the scanning process and enables the address and status lines from that calculator (see Fig. 2). These lines are common to all calculators connected to the system, so

only one calculator can use them at any given time. The data lines (8 lines) between the cache memory and the controller are also common, so the controller must enable these lines to the cache memory corresponding to the calculator requesting service.

The controller remains dedicated to this calculator until it has released its service request for about 750 milliseconds. Then the controller resumes scanning the service request lines. The scan rate is about 150 kHz. The scanning circuits are designed so there is a dead zone between the time that each service request line is checked. This guarantees that there will be no transients that could cause access to be granted to the wrong calculator.

Handshake Operation

The calculator and the controller operate asynchronously. To guarantee that they do not get out of step and misinterpret data, all address and command signals from the calculator are flagged and receipt acknowledged by the controller. Each time the controller acknowledges receipt of an address byte, the calculator checks the status lines to determine whether an error occurred. The controller does not always immediately acknowledge receipt; tests may be made on the information or some other operation performed first, but all transmissions are eventually acknowledged.

If an address error is detected during the transmission or reading of addresses, three attempts are made before the operation is terminated by the calculator. If a checkword error is detected in trying to read the data, ten attempts are made before the calculator gives up and displays an error message to the user. This technique makes momentary errors recover-

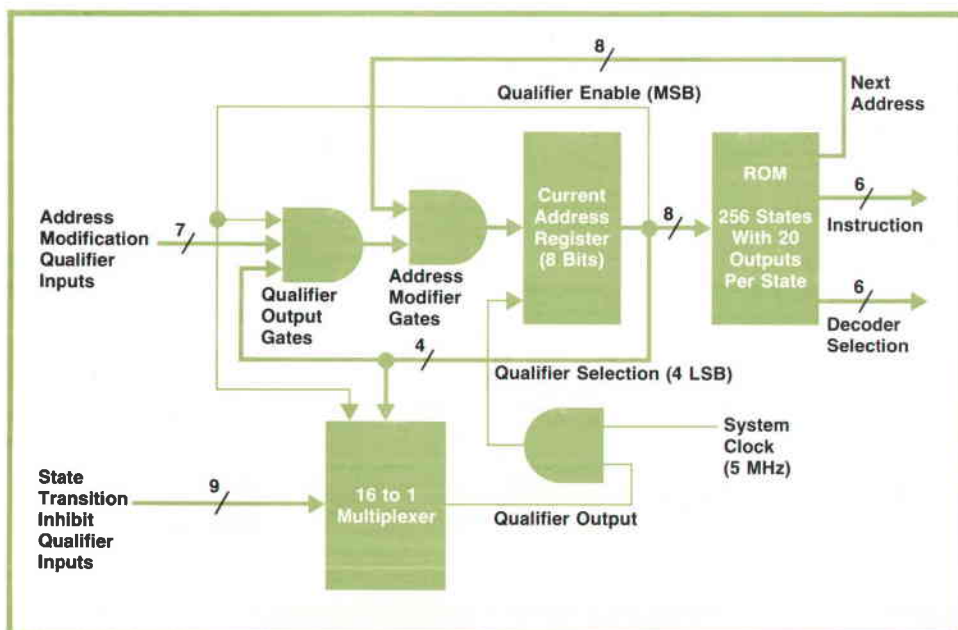

Fig. 9. Controller instructions and functions are stored in a 256-state bipolar ROM. One bit of the current ROM address determines whether the transition to the next address is qualified or unconditional.

able so the system is not affected by them.

Controller Hardware

All of the controller functions and instructions are contained in a 256-state, 20-output ROM (see Fig. 9). The clock frequency of 5 MHz required that the ROM be bipolar rather than MOS. The 20 outputs provide information for the next address state (8 lines), the coded instruction outputs (6 lines), and the instruction decoder selection bits (6 lines).

The most significant bit of the current ROM address determines whether the transition to the next address is qualified or unconditional. For qualified transitions, two types of qualifiers are used. One type modifies the NEXT ADDRESS data that comes from the ROM. This type is generally used when an exit must be made from a microprogram loop. The second type of qualifier prevents the NEXT ADDRESS from being clocked into the address register until the qualifier is satisfied. This type is particularly useful when an asynchronous event is expected but its time of occurrence is only approximately known. There are seven modifier qualifiers and nine inhibit qualifiers. In each type, the four least significant bits of the present

address determine which qualifier is to be selected.

Instructions

Six instruction decoder chips, each having four instruction bit inputs, generate the signals required to operate the system. These decoders are divided into three sets of two decoders each (see Fig. 10). Each decoder has a unique enabling bit that comes from the ROM. The six instruction bits from the ROM are decoded into 44 individual control lines for the system. The relationship between the ROM address states and qualifier selection and the interleaving of the instruction outputs made the ROM state assignments and microprogramming a very interesting and challenging task.

To avoid transients caused by the unequal switching times of the ROM outputs, all of the 44 control signals from the decoders are latched into flip-flops. The outputs of these flip-flops control the rest of the system. Each signal lasts 200 nanoseconds or a multiple of 200 nanoseconds. All instructions are latched on the next clock following their generation from the ROM. Because of the complexity, careful attention was given to gate delays and switching speeds.

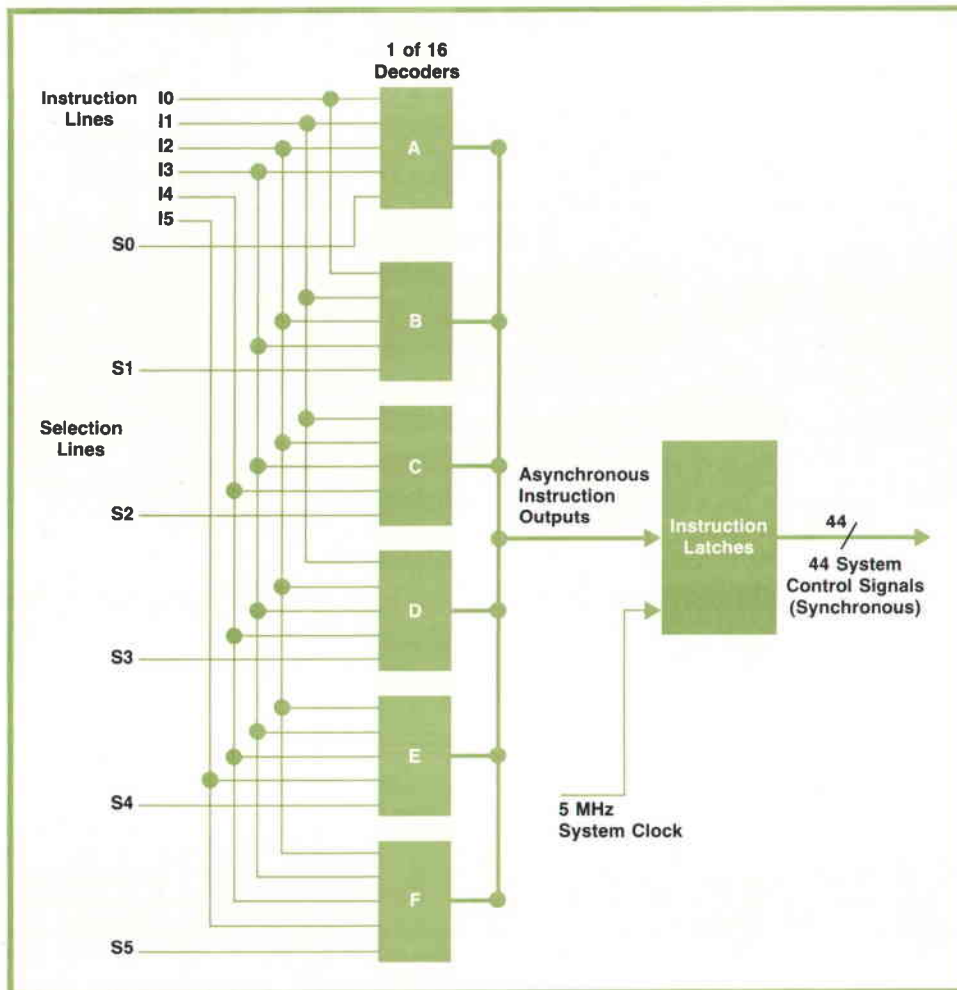

Fig. 10. Six-line instructions from the ROM are decoded into 44 lines to control the system.

Data Transfer

Data is transferred between the cache memory and the controller via an 8-bit data bus. Two 8-bit shift registers in the controller receive the data. The data is then transferred serially to the mass memory.

In a read operation, data from the mass memory is transferred serially into these registers, then in parallel to the cache memory. As soon as one shift register is filled, its contents are gated to cache memory while the second shift register is being filled. This requires 3.2 microseconds. Two write pulses, each one microsecond long, write 4-bit bytes into the cache memory. The remaining time is used to change the cache memory address for the second byte. The control circuits for cache memory keep count of the total number of bits transferred. When 256 words are completed, a signal is sent to the ROM qualifier and the operation is terminated.

Clock Switching

Normally, all of the system functions are controlled by the 5 MHz crystal clock. However, when data is read from the platter, the clock must be derived from this data. This poses a problem in that transfer from one clock base to the other must be accomplished without any transients that could cause false signals or cause the system to "get lost."

Two requirements must be met to avoid these problems. First the clock signal coming from the mass memory must be well established, and second, switching must take place at the beginning of a clock period to avoid any very short clock periods. Short clock periods are bad because the ROM needs a certain amount of time to respond to each clock pulse. If a clock pulse arrives too soon the ROM may jump to an incorrect address.

This problem is solved by the synchronization circuit shown in Fig. 11. This circuit allows the clock currently in effect to disable itself and the clock being

acquired to enable itself. To further minimize risk, no other instructions are given in the ROM state preceding and following the clock transfer state. With this approach it is possible that an extra long clock cycle may be generated during the switching process but not any short ones.

System Reliability

Multiple-calculator/multiple-mass-memory systems have accumulated more than 7500 unit hours of testing to establish their reliability. Extensive applications development has provided further testing. Systems have transferred more than 10^{10} bits between recoverable errors.

Hardware safeguards have been implemented to reduce the possibility of loss of the user's data. Both the 9867A and the 9867B have front-panel switches which, when set, prevent any writing on their platters.

Failures can occur in any system, of course, no matter how well designed it is. For example, if primary line power fails during a write operation, that data will be lost. Improper maintenance or lack of maintenance can cause the mass memory to malfunction and data can be lost. This emphasizes the need to provide backup for any critical data. A multiple platter system makes this backup quickly and easily accomplished. Tape cassettes are another means of backup data storage and the system software also makes this easily accomplished.

Acknowledgments

The authors gratefully acknowledge the contributions of Fred Wullschleger for product design and Rich Kochis for electronic design of the controller. Also, Cal Finn made strong contributions early in the project to system definition and electronic design.

Paul Morrison contributed to the support software development and Gene Burmeister to development

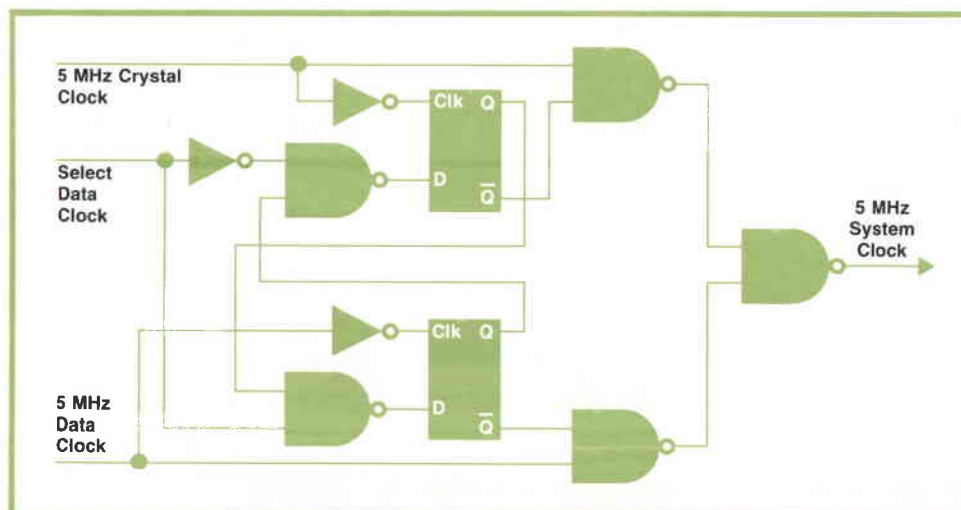

Fig. 11. 5-MHz crystal clock controls the system except during read operation, when the clock signal is derived from the data. This circuit synchronizes switching from one clock to the other.

of the special commands. Special thanks go to Jack Walden for his software help and invaluable group leadership. Much credit also is due to the many people who contributed to software testing.

The authors would also like to express their appreciation to Chuck Near, peripherals section manager, and Chuck McAfee, group leader, for their suggestions and encouragement throughout the project.

Larry Mitchell, Joe Arata, Curt Kohanec, and Mike Bir of the Mountain View Division also deserve special thanks for their help in the sometimes trying task of bringing the 9867A and 9867B Mass Memory drives to production for the 9880 Mass Memory System.

Much of the work of transferring to production was taken over by technicians Norm Carlson and Terry Smith. A grateful acknowledgment is also made to the many people from the facility shops and

production areas whose efforts have made this project a success. ☺

References

1. R.M. Spangler, "BASIC-Language Model 30 Can Be Calculator, Computer, or Terminal," Hewlett-Packard Journal, December 1972.
2. J.E. Herlinger and J.R. Barnes, "A Faster and Tougher Disc Drive for Small Computer Systems," Hewlett-Packard Journal, May 1972.
3. J.E. Herlinger and W.J. Lloyd, "Inside the 7900 Disc Drive," Hewlett-Packard Journal, May 1972.
4. G.L. Egan, "Versatile Input/Output Structure Welcomes Peripheral Variety," Hewlett-Packard Journal, December 1972.
5. W.I. Girdner and W.H. Overton, "Reading and Writing on the Fast Disc," Hewlett-Packard Journal, May 1972.
6. D.J. Bowman, "An Efficient Disc Drive/Computer Interface," Hewlett-Packard Journal, May 1972.

SPECIFICATIONS

HP Model 9880A/B Mass Memory System

DATA CAPACITY AVAILABLE TO USER:

	9880A	9880B
BYTES	2,433,024	4,866,048
BYTES PER WORD	2	2
WORDS PER RECORD	256	256
NUMBER OF RECORDS	4,752	9,504(4752/platter)
MAXIMUM NUMBER OF FILES	768	1,536(768/platter)

SPEED:

	9880A	9880B
AVERAGE ACCESS TIME	47.5 ms	42.5 ms
DATA TRANSFER TIME	5.7 ms	5.7 ms
	per 512 bytes	per 512 bytes
	(Mass Memory to Calculator or vice versa)	

ENVIRONMENTAL (ENTIRE SYSTEM):

TEMPERATURE:
Operating: 10 to +40°C
Non-operating: -20 to +65°C

ALTITUDE: 0 to 10,000 feet

HUMIDITY: 8 to 80% non-condensing

VIBRATION: 10 to 50 Hz at 0.01 inch peak-to-peak excursion

ATTITUDE: ±30° pitch and roll

AIR FILTRATION:

	9867A Mass Memory Drive	9867B Mass Memory Drive
ABSOLUTE FILTERING	0.3 micron	0.3 micron
AIR FLOW RATE	25 CFM	75 CFM

PRICES IN U.S.A.: 9830A Calculator with 7616 bytes of read/write memory and String Variable ROM, \$8495.

9880A (single platter) System, \$10,945.

9880B (dual platter) System, \$12,995.

(9880A/B prices do not include calculator.)

Installation (Option 101), \$200.

Applications software packages, \$500 each.

9866A Thermal Page Printer, \$2995.

MANUFACTURING DIVISION: CALCULATOR PRODUCTS DIVISION

815 Fourteenth Street SW
Loveland, Colorado 80537 U.S.A.



Havyn E. Bradley (left)

Havyn Bradley received his BA degree from Harvard University in 1962 and his MSEE degree from the University of Wyoming in 1966. He's been with HP since 1966. Havyn has contributed to the development of the 745A AC Calibrator and the 9100 A Calculator system, and has served as produc-

tion engineer for the 9100A and as project leader for the magnetic card reader in the 9810A and 9820A Calculators. He was hardware project leader for the 9880A/B Mass Memory System. Havyn is married and has four children, whom he's teaching to program the 9820A Calculator. He's served as advisor to two Junior Achievement companies and once coached a women's softball team. Topping his list of favored recreational pursuits are fishing, hiking, and touring on his motorcycle, activities for which Colorado offers a superb setting.

Chris J. Christopher (right)

Chris Christopher was born in Greece, came to the U.S.A. in 1961, and graduated from Colorado State University in 1968 with a BSEE degree. At HP since 1968, Chris has been involved with computerized testing and production of 9100 series calculators and peripherals and with cassette software development for the 9830A Calculator. He was software project leader for the 9880A/B Mass Memory System. Having continued his studies while at HP, Chris received his MSEE degree just last month from Colorado State. He and his wife live in Loveland, Colorado, and frequently take advantage of the skiing in the nearby Rocky Mountains. Chris is a member of IEEE.

An Easily Calibrated, Versatile Platinum Resistance Thermometer

Unusual features of this digital thermometer are a choice of normal or expanded resolution, linear analog output, interchangeable probes, and many options including a battery pack and digital output.

by Tony E. Foster

DIGITAL THERMOMETERS ARE convenient high-resolution instruments that are widely used both in laboratories and in industry when the ultimate in laboratory-standard temperature accuracy isn't required. General-purpose digital thermometers usually have three- to five-digit displays. Their temperature-sensing elements may be platinum or nickel resistance wires, thermocouples, thermistors, or other solid-state devices.*

Model 2802A Digital Thermometer, Fig. 1, is a new 4½-digit platinum resistance thermometer designed to measure a broad range of temperatures with greater-than-ordinary versatility, ease of use, and economy. The new thermometer is a dual-range instrument that measures temperatures between -200°C and +600°C with 0.1°C resolution, or between -100°C and +200°C with 0.01°C resolution. Accuracy in both ranges is specified as $\pm 0.5^\circ\text{C} \pm 0.25\%$ of reading, which means that a reading of 0°C is accurate within $\pm 0.5^\circ\text{C}$, readings of $\pm 200^\circ\text{C}$ are accurate within $\pm 1^\circ\text{C}$, and a reading of +600°C is accurate within $\pm 2^\circ\text{C}$. These specifications are for the entire system including the probe, and are conservative.

A standard feature of the instrument is rear-panel analog output, which provides a voltage proportional to the measured temperature for monitoring, recording, or feedback purposes. The output voltage is equal to one millivolt per degree on the normal range and ten millivolts per degree on the expanded-resolution range. The accuracy of the output voltage is the same as that of the digital display.

An important characteristic of the new thermometer is its system design, which provides a great deal of versatility. There are three basic elements: display, thermomodule, and probe. The display is a stan-

dard Model 34740A, a member of the 3470 Measurement System¹; it forms the top half of the instrument. The thermomodule, which contains probe input and sensor-linearization circuits, references, and analog output circuits, is the bottom half. Between the display and the thermomodule the user may insert one or both of the two center modules of the 3470 System, a battery pack and a BCD digital output module. Thus the thermometer can be completely portable and/or be part of a digital data acquisition system.

It is also possible to replace the thermomodule with other modules of the 3470 System, which in-

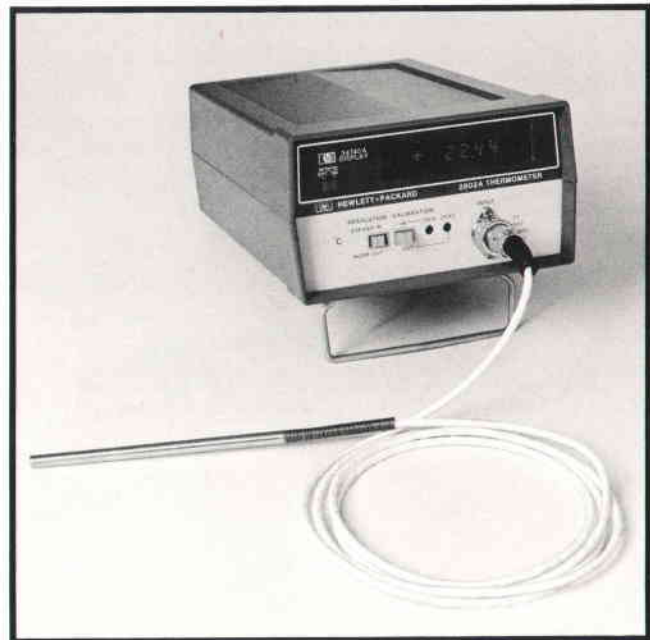

Fig. 1. Model 2802A Thermometer measures -200°C to 600°C with 0.1°C resolution or -100°C to 200°C with 0.01°C resolution. Compatibility with the 3470 Measurement System provides versatility and expandability.

*An exception is Hewlett-Packard's Model 2801A Quartz Thermometer, a super-high-resolution digital thermometer that is probably more properly classified as a special-purpose instrument.

clude digital voltmeter and multimeter modules. Users who already have a 3470 System need only acquire the thermomodule to gain temperature-measurement capability. The thermomodule is also compatible with the 5½-digit 34750A display module; the last digit is blanked when the thermomodule is attached.

Besides making the thermometer a versatile instrument, the system design makes it possible to start with just a basic system and add other capabilities later at modest cost.

Why Platinum?

The basis of any measurement is the sensor. The reliability of the measurement depends first on how well the sensor's characteristics can be specified and then on how well the sensor information can be linearized for presentation to the user.

Of the commonly used sensors for general-purpose digital thermometers platinum is the most stable and most easily linearized. Platinum sensors also have good range (-250° to $+800^{\circ}\text{C}$). They are more costly than either thermocouples or thermistors, and their minimum size is larger. But thermistors suffer from instability and limited temperature range, and thermocouples, while they have broad range (up to 1800°C), are difficult to linearize and require good reference junctions, which are difficult to obtain.

Platinum is used as a temperature standard by the United States National Bureau of Standards² and is the basis for the International Practical Temperature Scale (1968).³ Thus its characteristics are well known.

Platinum resistance sensors are in common use in industry. Typically, they are linear within $\pm 10\%$ between -200°C and $+600^{\circ}\text{C}$. Also, there is a particular-

ly simple and accurate way to linearize them.

For all these reasons, platinum resistance wire was chosen as the sensor for the new thermometer. Four different types of sensor probes are available (see Fig. 2 and specifications, page 17).

What's Inside

The goal in the electronic design of the 2802A Thermometer was to make maximum use of the accuracy of the sensor, but not at the expense of versatility, ease of use, and low cost.

To study the effects of changes in various parameters on accuracy, proposed designs were simulated using an HP 9810A Calculator and a 9862A Plotter. Among the parameters varied were probe specifications (i.e., nominal resistance R_0 and nominal slope $\alpha = dR/dT$), lead resistance, degree of linearization, amplifier gain stability and dc drift, temperature coefficients of electronic components, and calibration methods. A four-wire, autozeroed, resistance ratio measurement technique was decided upon.

The 34740A display was chosen because it provided a dual-slope analog-to-digital converter, a 4½-digit display, power supplies, and a convenient package, and because the required engineering effort should be greatly reduced by using an existing instrument.

The major part of the thermometer design was in the thermomodule. The principal circuits are a linearizer, a current source, a reference circuit, autozero circuits, and an analog output buffer (see Fig. 3).

Linearization Simplifies Calibration

If the resistance-versus-temperature characteristic of platinum were linear, a voltage proportional to temperature could be derived simply by sending a known current I through the sensor and detecting the resulting voltage $I_0 R_s$, where R_s is the sensor resistance. However, R_s is not a linear function of temperature. As Fig. 4 shows, the resistance-versus-temperature characteristic of platinum departs from the ideal linear characteristic, especially at higher temperatures.

To cancel the nonlinearity of the sensor a nonlinear amplifier is used. Positive feedback is added around the sense amplifier (i.e., the input amplifier), making its effective gain increase as the sensor resistance increases with temperature (see Appendix). The linearization is typically accurate within $\pm 0.5^{\circ}\text{C}$ worst case over the range of -200°C to $+600^{\circ}\text{C}$. Fig. 5 is a linearity plot for a typical sensor after linearization.

An advantage of this analog method of linearization is that there are no discontinuities in the displayed temperature as the temperature changes. This is sometimes a problem when piecewise-linear com-

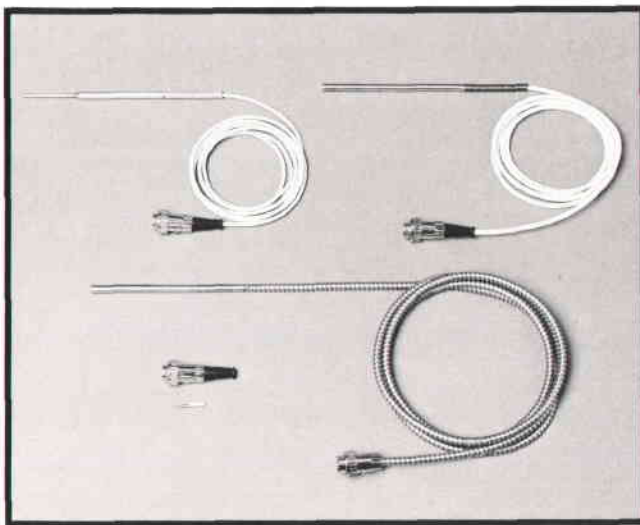

Fig. 2. Four types of platinum resistance probes are available. A change of probes requires only a simple recalibration that can be performed by the user.

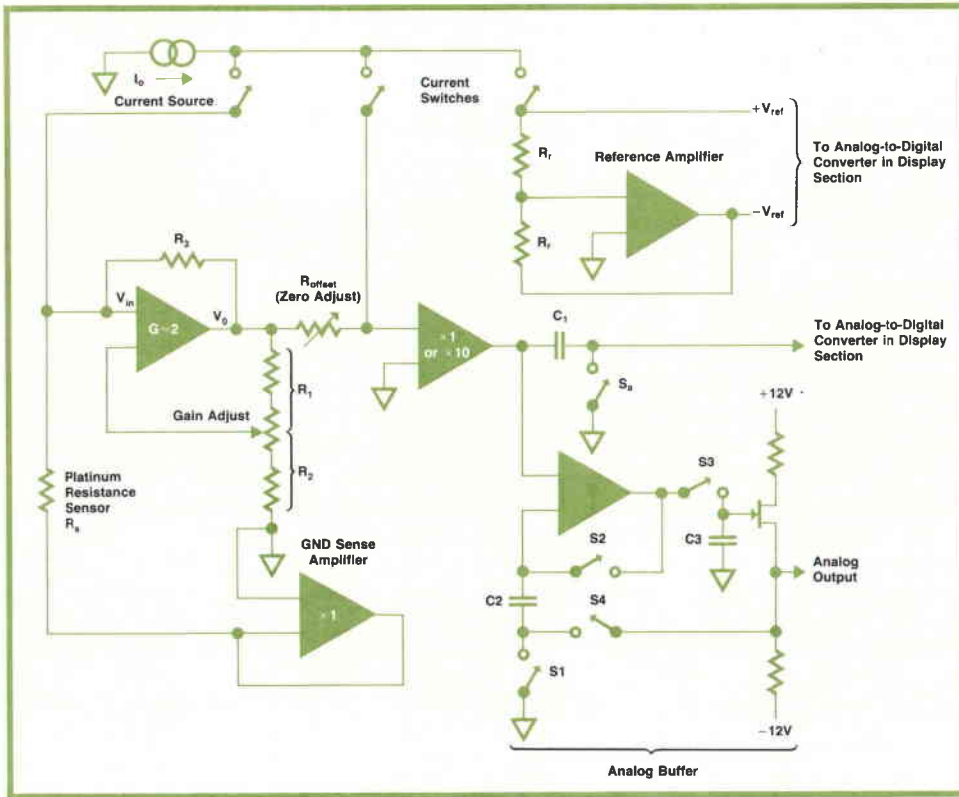

Fig. 3. Thermomodule (bottom half of instrument) contains a linearizer, a current source, a reference circuit, autozero circuits, and an analog output buffer. Dual-slope analog-to-digital conversion is done in the display module. The thermometer makes a four-wire resistance ratio measurement.

pensation networks or read-only memories are used for linearization.

The analog linearization method also makes probe calibration a simple task that can be performed by the user. To get maximum accuracy, the instrument and the probe must be calibrated together because of inherent probe-to-probe variations in sensor characteristics. Calibration has usually been done by the instrument manufacturer, but if a probe is damaged or changed, the entire instrument must be returned to the factory, a cumbersome arrangement.

With the 2802A, on the other hand, a probe can be matched to the instrument simply by immersing the probe in an ice bath and making two front-panel adjustments. This one-point calibration is possible because smooth analog linearization is used. The gain-determining components are fixed, which means that if the gain is known at one temperature it is known at all temperatures.

After linearization, the temperature characteristic of the system is theoretically a straight line and can be defined by its slope and one point. The slope is determined by the gain of the system. With the probe characteristics (R_0 and α) properly specified, the gain required at 0°C is easily determined. When the user calibrates the system at 0° he first sets the gain to this value. With the CAL button IN (this disables the center current switch in Fig. 3 so it never closes) and the probe in an ice bath, the user makes a front-panel adjustment so the display reads .2.4.0.8. This sets the

gain. Then with the CAL button OUT and the instrument operating normally, he makes another front-panel adjustment so the display reads all zeros, the temperature of the ice bath. This sets the required point on the line. Having set the slope and one point on the temperature characteristic, the user has calibrated the system.

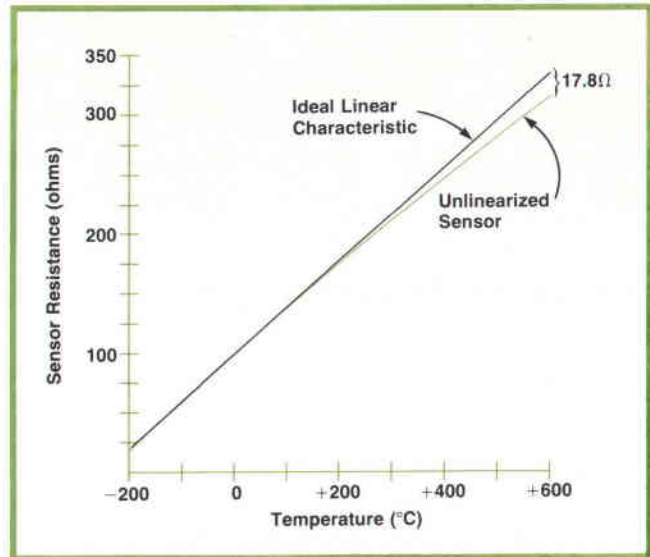

Fig. 4. Linearizer corrects the R -vs- T characteristic of platinum. Analog linearization avoids the discontinuities of piecewise-linear and ROM methods and makes feasible a simple one-point user calibration procedure.

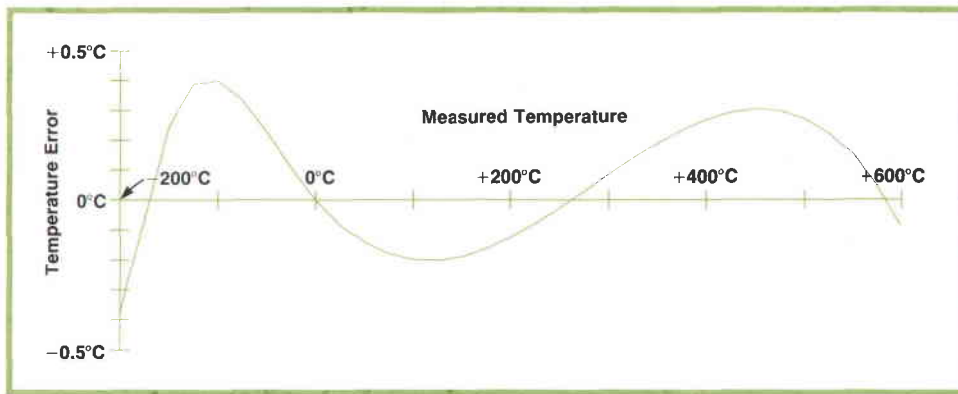

Fig. 5. After linearization, deviations from linearity are less than 0.5°C over the entire temperature range. Specified accuracy of $\pm 0.5^\circ\text{C} \pm 0.25\%$ of reading includes all instrument and probe errors.

Calibrations done at one ambient temperature are valid even if the ambient temperature changes by $\pm 5^\circ\text{C}$. Because of the way they are specified and calibrated, all HP probes are completely interchangeable. After a change of probes the user need only repeat the ice-bath calibration procedure and the instrument will meet its published specifications.

Ratio Measurement

In the 2802A the reference current I_0 is generated by the three-output current source shown in Fig. 6. The operational amplifier compares the voltage across the current-sense resistor R_c with the voltage V_r and adjusts the bias voltage on the gate of one of the three field-effect-transistor current-pass elements to keep the voltage across R_c , and therefore the current through it, constant. Logic signals cause one and only one of the three FET's to be turned on at any time.

The dual-slope analog-to-digital converter in the display section makes it possible to perform a ratio measurement by time-sharing the current source. First the current is applied to the sensor, and the A-to-D converter integrates the voltage $I_0 R_s$ for a fixed time. The current is then switched to the reference resistors R_r in Fig. 3, and the A-to-D converter integrates the resulting voltage downwards until its output reaches zero. The time required to integrate down to zero is proportional to $I_0 R_s / I_0 R_r$. I_0 cancels and R_r is chosen so the unknown temperature can be measured directly by counting the rundown time. Thus the measurement is a resistance-ratio measurement and its accuracy is dependent primarily on the accuracy of the reference resistor.

An advantage of the dual-slope analog-to-digital conversion is that any long-term changes in the current source, the clock, or the integrator do not affect the accuracy of the measurement.

Autozero Cancels Errors

During the autozero periods, which alternate with the measurement periods, switch S_a (see Fig. 3) is closed and the current I_0 is switched to flow through R_{offset} . In a properly calibrated instrument, the voltage

across this resistor is then equal to the output of the linearizer at zero degrees Celsius. This voltage and any amplifier-offset error voltages are stored on capacitor C1. Then, during the measurement period, S_a opens and the voltage on C1 is subtracted from the linearizer output voltage, thereby cancelling the errors.

Autozero cancels the effects of drift in the dc amplifiers and any thermocouple effects in connectors. Thus little sensor current is needed and self-heating is negligible. Less than 0.1 milliwatt is dissipated in the sensor.

To make the measurement independent of the resistance of the probe cable a four-wire measurement technique is used. Two leads drive current through the sensor and two different leads sense the voltage across the sensor. Any voltage drop in the sense leads caused by amplifier bias current in the lead resistance is cancelled during the autozero cycle. The ground sense amplifier shown in Fig. 3 provides a return path for the sensor current while assuring that the ground lead of the sensor is at ground potential.

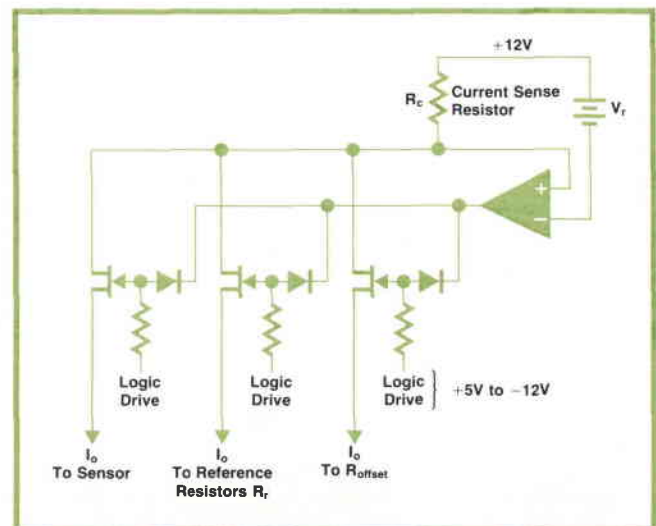

Fig. 6. Current source has three outputs that are switched on one at a time to send the reference current to the sensor, to a set of reference resistors, or to the autozero circuits.

Analog Output Also Autozeroed

The analog output buffer is an autozeroed sample-and-hold circuit. During the autozero period switches S1 and S2 are closed and S3 and S4 are open. A voltage representing errors and zero offset is stored on capacitor C2. Then during the measurement period S1 and S2 open and S3 and S4 close, thereby closing the loop so the output voltage tracks the input voltage minus the voltage on C2. Capacitor C3 stores the output voltage between measurements.

Acknowledgments

Many thanks are due Doug Smith (the originator of the linearization scheme), Stu Hansen, Chet Haibel, and Bill Petersen. I would also like to thank Dave Stead, Parkie Low, and Alson Wong for their help in getting production started. 📧

SPECIFICATIONS HP Model 2802A Thermometer

These specifications are "total system specifications" meaning they apply to both the instrument and the probe working together.

RANGES: -200 to +600°C and -100 to +200°C

RESOLUTION: 0.1°C on -200 to +600°C range, 0.01°C on -100 to +200°C range

ACCURACY: ±(0.5°C ±0.25% of reading) on both ranges

DISPLAY: 4½ digits LED on HP 34740A Module

STABILITY: ±0.2°C for 7 days (23°C ±5°C ambient)

LINEAR ANALOG OUTPUT: 1 mV/°C on -200 to +600°C range, (-0.2 V to +0.6 V F.S.), 10 mV/°C on -100 to +200°C range (-1.0 V to +2.0 V F.S.)

Voltage accuracy equal to that of digital display. Output impedance 1 kΩ on both ranges.

ENVIRONMENTAL STANDARD: HP 2802A Thermometer operates within these specifications in environments of 0 to 50°C and up to 95% relative humidity over most of this temperature range. After calibration in some arbitrary ambient temperature, instrument calibration remains valid with ambient temperature changes up to ±5°C.

POWER REQUIREMENTS: Operates on any of four single phase ac line voltages 100 V, 120 V, 220 V, 240 V rms (+5%, -10%), 48 Hz to 440 Hz. Power dissipation is 8.7 volt-amperes.

DIMENSIONS: Thermomodule with display unit is 159 mm wide, 98 mm high, 248 mm deep (6¼ × 3¾ × 9¾ in); net weight is 2.27 kg (5 lb), shipping weight about 3.39 kg (7½ lb).

PRICES IN U.S.A.:

2802A Digital Thermometer complete with 4½ digit 34740A Display, requires HP 18640 series probe (see list below), \$700.

Option 001 Digital Thermomodule thermometer unit only, without display unit or probe. NOTE: Since thermomodule will not operate without display, this option is for those planning to use thermomodule with their own HP 34740A or HP 34750A Display Modules. Deduct \$325.

PROBES:

NOTE: Time constant for probes measured in water flowing at 3 meters per second.

18641 Probe, 13 cm stainless steel sheath, 6.4 mm diameter, with armored cable 1.83 m long; for -200 to +500°C, to +600°C short term (prevent cable movement above 250°C); time constant 5s. \$165.

18642 Probe, same as 18641 probe except with 1.83 m Teflon-insulated cable; cable must be kept below 250°C. \$150.

18643 Probe, 13 cm stainless steel sheath, 6.4 mm diameter, with last 5.1 cm of sheath tip reduced to 3.2 mm diameter; for -200 to +500°C, to +600°C short term; Teflon cable 1.83 m long, must be kept below 250°C; time constant 1.8s. \$180.

18644 Probe Kit, includes platinum sensor cartridge, 1.3 cm × 0.25 cm diameter, having two nickel leads, 1 cm × 0.03 cm diameter, cable connector, wiring diagram for four-wire hookup; time constant 0.5s. \$105.

MANUFACTURING DIVISION: SCIENTIFIC INSTRUMENTS DIVISION
1601 California Avenue
Palo Alto, California 94304 U.S.A.

References

1. A. Gookin, "Compactness and Versatility in a New Plug-Together Digital Multimeter," Hewlett-Packard Journal, August 1972.
2. J.L. Riddle, "Notes to Supplement Resistance Thermometer Reports on the International Practical Temperature Scale of 1968," United States National Bureau of Standards, April 1, 1969.
3. "The International Practical Temperature Scale of 1968," Metrologia, Vol. 5, No. 2, April 1969.

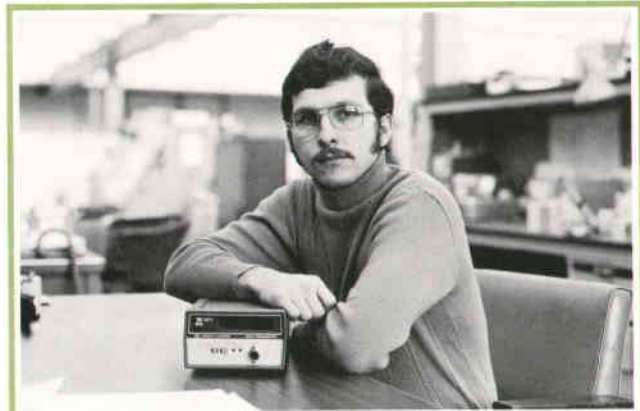

Tony E. Foster

Tony Foster was project leader for the 2802A Thermometer. A native of Indianapolis, Indiana, Tony graduated from Case Institute of Technology in 1970 with a BSEE degree, then joined HP's Scientific Instruments Division in California. There he's also contributed to the design of the 8330A/8334A Optical Power Meter and the 5950A ESCA Spectrometer. Tony hopes to get his MSEE degree from Stanford University later this year. And to balance the relatively sedentary occupations of engineer and student, he keeps in shape with jogging, swimming, scuba diving, bicycling, and tennis.

APPENDIX Analog Linearization

In the 2802A Thermometer, platinum resistance temperature sensors are linearized by adding positive feedback to the sense amplifier. This feedback is represented by R_3 in Fig. 3.

Without feedback, the gain of the amplifier is

$$G = (R_1 + R_2)/R_2 > 1$$

and the output voltage is

$$V_o = V_{in} G = I_o R_s G.$$

With feedback, V_o becomes a nonlinear function of R_s :

$$V_o = R_3 I_o R_s G / (R_3 + R_s - G R_3)$$

$$V_o = I_o R_s G_e$$

where the effective gain G_e is given by

$$G_e = G R_3 / (R_3 + R_s - G R_3).$$

Thus with feedback, the effective gain of the amplifier increases as R_s increases, i.e., as the temperature increases. With properly chosen parameters, this tends to cancel the nonlinearity of the R_s -vs-T characteristic of platinum.

Speeding the Complex Calculations Required for Assessing Left Ventricular Function of the Heart

Adapting computers to medical tasks has been slower than originally anticipated, going step-by-step as truly suitable tasks are identified and implemented. Here's another example of how a computer can help out when a suitable task is identified.

by Peter Dikeman and Chi-ning Liu

THE ANALYSIS OF A CINEANGIOGRAM—a dynamic photographic recording of fluoroscope images of blood vessels—is one of the major clinical diagnostic procedures in the assessment of heart function. The procedure involves injecting radiopaque dye into the blood stream in different parts of the heart. Under the X-ray fluoroscope, the outline of the different chambers of the heart and large blood vessels are clearly visible. This X-ray image can then be recorded on cine film to provide a dynamic, real-time record of blood flow through the blood vessels and heart chambers. The left ventricular cineangiogram is a major diagnostic tool for the assessment of ventricular function.

Analysis of a left ventricular cineangiogram provides measurements of ventricular volumes at different points in time during the cardiac cycle. From these volume measurements, parameters vital to ventricular function can be derived.

Review of Basic Theories

The basic methods commonly used in measuring ventricular volume from the ventricular angiogram are as follows.

The Biplane Area Length Method¹. The anteroposterior (frontal) view and the lateral view of the left ventricle image are recorded simultaneously by biplane X-ray equipment. Fig. 1 shows a sample of the film and the parameters used for the calculations. The areas are usually measured by using a planimeter.

The area-length method postulates that the left ventricular cavity can be represented by an ellipsoid and that the volume can be calculated using the following formula:

$$V = \frac{4\pi}{3} \times \frac{D_a}{2} \times \frac{D_e}{2} \times \frac{L}{2} \quad (1)$$

where

D_a = Minor axis in the anteroposterior view.

D_e = Minor axis in the lateral view.

L = Major axis, i.e., the longest measured length regardless of whether it is in the AP or lateral view.

The two minor axes, D_a and D_e are calculated as follows:

$$D_a = \frac{4A_a}{\pi L_a} \quad (2)$$

$$D_e = \frac{4A_e}{\pi L_e} \quad (3)$$

where

A_a = Area of the projected image in the AP view.

A_e = Area of the projected image in the lateral view.

L_a = Largest measured length in the AP view.

L_e = Longest measured length in the lateral view.

The Biplane Integration Method². This method is based on the assumption that the cross-sectional outline of the left ventricle is approximately circular or elliptical. It requires successive measurements of corresponding cross sectional axes at fixed intervals from the biplane cine image as shown in Fig. 2. The left ventricle is thus divided into "slices", and the volume of each slice is calculated by:

$$\Delta V = h (A \times B)/4 \quad (4)$$

where

ΔV = Volume of each segment

h = Thickness of each segment

A = Axis in the lateral view

B = Axis in the lateral view

Based on a modification of Simpson's Rule, the total left ventricular volume is given by

$$V = \frac{\pi h}{3} \left(\sum_i^{\text{odd}} A_i B_i + \sum_j^{\text{even}} 1/2 A_j B_j \right) \quad (6)$$

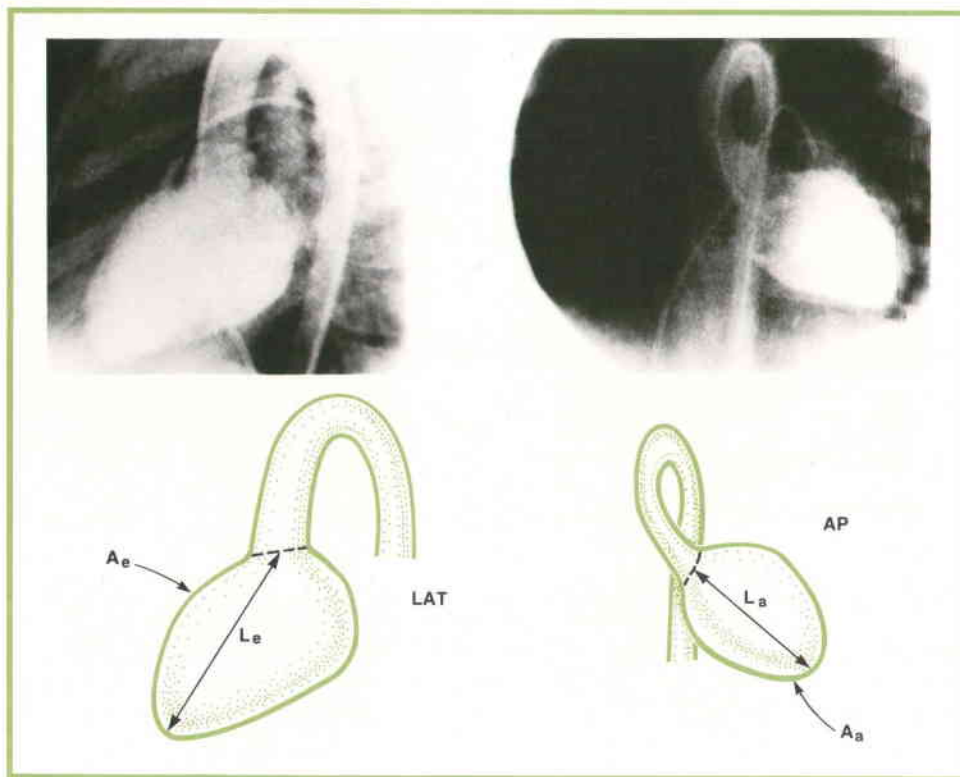

Fig. 1. Typical angiograms showing the left ventricle and aorta with dye injected. The photo on the left shows the x-ray view from the side and the one on the right shows the heart as viewed by the fluoroscope from the front. The drawings show the parameters that are measured for calculation by the biplane area-length method.

The Single Plane Area-Length Method³. This is a simple technique specially developed for those laboratories which may not have biplane X-ray facilities. In this method, the minor axis in the lateral projec-

tion D_e in equation (1) is assumed to be equal to the minor axis in the frontal (AP) projection D_a , i.e., the left ventricle is assumed to be an ellipsoid of revolution. Therefore, equation (1) becomes:

$$V_a = \frac{\pi}{6} D_a^2 L \quad (6)$$

Under many circumstances, this method yields a close approximation to the values obtained from the corresponding biplane method.

Although several other methods have been used for volume calculation, the above summarizes all the common techniques used today.

Correction Factors

In calculating the volume by any of the above methods, each measurement taken from the film must first be corrected for X-ray magnification using the following formula (Fig. 3):

$$M = H/(H-P) \quad (7)$$

where

H = X-Ray Tube to image plane Distance

P = Object to image plane Distance

Linear measurements are corrected by dividing with this factor. Similarly, area measurements are corrected by dividing with the square of the factor.

After the volume is calculated, it must further be corrected for the inaccuracies of the assumptions made in the process of modeling the left ventricle. This correction is accomplished by applying a linear regression equation of the form

$$V_{\text{True}} = V_{\text{Calc}} \times A + B \quad (8)$$

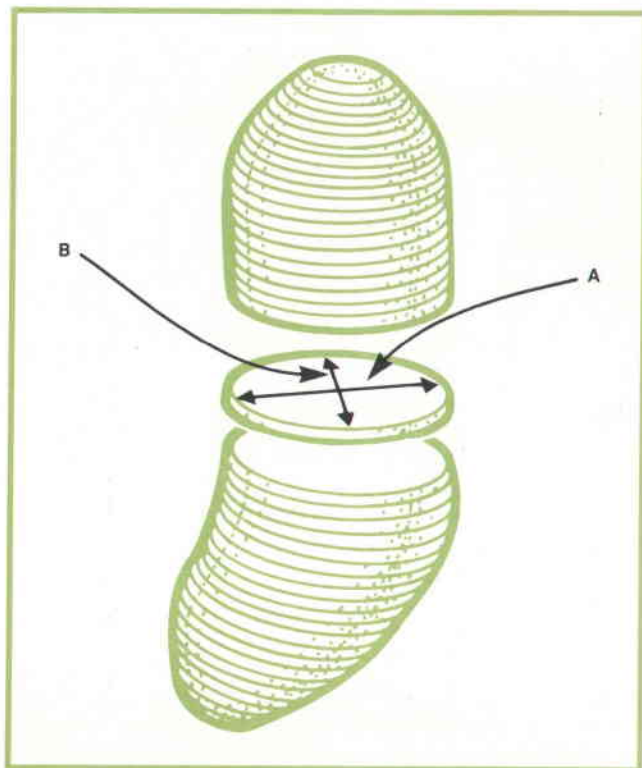

Fig. 2. Biplane integration method.

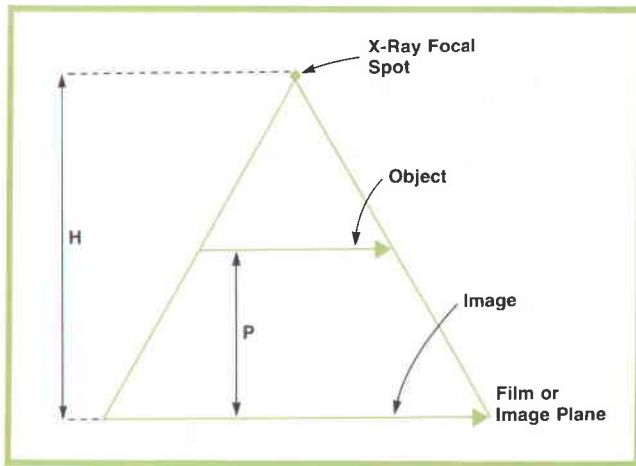

Fig. 3. Correction factors for X-ray magnification.

The constants A and B are empirically determined (typically $A = .98$ and $B = -1$ ml).

Defining a System

The conventional procedure for analyzing the left ventricular function from a cineangiogram involves measuring the image areas by tracing the image with a planimeter, then defining and measuring the different axes. A magnification correction factor is calculated and applied to the measurements. These corrected measurements are then substituted into one of the volume equations described above. The true volume must then be obtained by applying the volume

regression equation to the calculated volume.

If a diagnosis calls for analysis of a complete cardiac cycle, many frames (15 or more) must be processed. This is a task that may require more than a day's effort, so it is not done routinely. Therefore, if the technique is to be used as a routine clinical procedure, there is a definite need for automation.

In designing a system for automated analyses of cineangiograms, the major design considerations would be:

- Flexibility. The system package should be modular and flexible so that it can be interfaced with a variety of X-ray equipment and so that it can accommodate different methods for the analyses.
- The data acquisition medium should be based on the standard cineangiogram (16 mm or 35 mm). Equipment for photographing fluoroscope images and for processing the films rapidly is widely used in the cath lab and its operation is well understood by hospital personnel. A video record, such as video tape or disc, is not suitable at the present time; video tape has poor frame control, a video disc has limited storage and both are limited to a frame rate of 30 frames/second.
- Operation should be simple, requiring minimum training.

Hardware Description

It was decided to make the new angiogram capability an interactive hardware-software subsystem for use with the Model 5690B Cath Lab System, a disc-



Fig. 4. Angio-analyzer uses a cineprojector and a rear-projection screen with a front-viewing surface that eliminates parallax errors. The position digitizer has a linear microphone along the top edge of the screen and another along the left edge; it measures the times taken for ultrasound pulses to travel from the pen to each microphone, from which the computer calculates distance. The position of the symbols on the "keyboard" are interpreted as symbols by the computer.

based computerized system for obtaining blood pressure waveforms from which other vital information about the heart's function is derived⁴. There would be an overlapping data base so that the cath lab information (pressure and other patient data) would be readily available for the ventricular function analyses.

The new system is based on use of the standard cine-angiogram (16 or 35 mm). The projection unit is mounted on a projection stand that provides a rear-projected image of the angiogram on a 32 cm × 37 cm viewing screen. The projected image is formed on the outer surface of the viewing screen to avoid parallax errors. The projector has variable speed control, single frame advance control, and a forward-reverse switch.

The next step was to provide means for getting the data from the films into the computer. This is done with a commercially-available digitizer, a device that mounts on the projection screen (Fig. 4). The physician traces the area to be analyzed on each frame as he used to do with the planimeter but now he uses an electronic pen from which X-Y coordinate data is automatically derived and entered into the computer. To give visual verification of the area being traced, the computer displays the series of coordinate points on a video monitor.

Using a Pen to Talk

An additional means of communicating with the computer is essential. Although the Model 5690B Cath Lab System already includes a keyboard, this is usually installed where it is most convenient for those conducting the cath lab procedure. The system also has a teletype terminal, but this is in the office or computer room so that its noise will not intrude on those performing the cath lab procedure.

Obviously, a means of communication should be conveniently available to the physician performing the angiogram analysis. The X-Y digitizer provided a convenient answer to this need. A drawing of a keyboard is placed in the upper right hand corner of the projection screen (Fig. 4). All the physician needs to do is to touch one of the "keys" with the electronic pen, and the computer then recognizes that coordinate data as a command. This turns out to be particularly convenient because the physician does not have to put the pen down to talk to the computer. The alpha-numeric are echoed on the video monitor to provide visual feedback.

The equipment thus assembled for the physician is shown in Fig. 4. A block diagram of the complete system is shown in Fig. 5.

The Program

Finally, there is the software. Since this was to be a subsystem of the 5690B cath lab system, it was designed to work within the same computer hardware and software configurations.

The software is modular in form and consists of one Master program and nine segments organized as in Fig. 6. The Master program contains a "menu" that allows the user to choose and execute one of these segments (Fig. 7). Note that all segments except "off" return to the Master program after completion. This allows a great deal of flexibility since the segments do not have to be executed in any particular order.

The functions of the segments are as follows:

Set Program Parameters

This segment allows the user to calibrate the system by entering the raw data required to calculate the magnification/distortion of the x-ray system. It

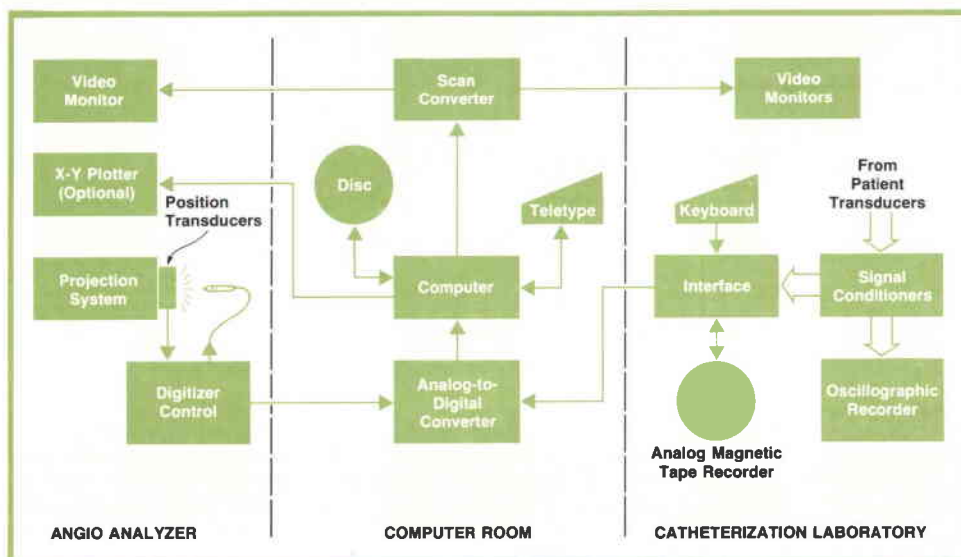

Fig. 5. Block diagram shows how angio-analyzer ties into cath lab system.

also allows the user to display and/or change the various program constants. Normally, these constants are set at program configuration time and probably will not be changed except for research or special cases such as a change in x-ray equipment or a special patient.

Patient Data Entry

This segment sets up files for new patients and allows the entry and editing of patient data (name, hospital identification number, height, weight, etc.).

Trace LV

This segment allows the entry of left ventricle (LV) tracings. The boundary of the LV is traced with the digitizer pen and the trace is displayed on the video monitor for operator verification. Upon operator confirmation, LV volume and wall thickness are calculated and displayed, as shown in Fig. 8.

Input LV Pressures

Allows the entry of LV pressures either as numeric data or by projecting a recording of the pressure waveform and using the digitizer.

Analyze

Calculates derived parameters from calculated volume data previously entered. Fig. 9 shows typical results.

Report

Generates a report on the video monitor, or a hard copy report on the teletype, of all volumes and

derived parameters calculated to date.

Plot

This segment plots any user-selected derived parameters on the monitor and/or optional X-Y plotter (P-V loops, pressure vs. time, etc.), as in Fig. 10.

File Manager

Permits listing the patient file directory, deleting a patient file and changing the current patient file.

Off

Terminates the program and returns control to the computer executive.

All the programs except the I/O controls are written in FORTRAN. One unique feature of the software is the use of a centralized formatting scheme. All formats are stored in a single disc-based Source File. This allows all operator messages to be converted to languages other than English without re-compiling any programs.

Conclusion

With the addition of the 5693A to the HP 5690B Cath Lab System, the physician can now study the hemodynamic problems of the heart by not only looking at the heart as a pump through pressure analysis, but also assessing the left ventricle function quantitatively through the analysis of its muscle geometry. The system uses the tools at hand, adding only the

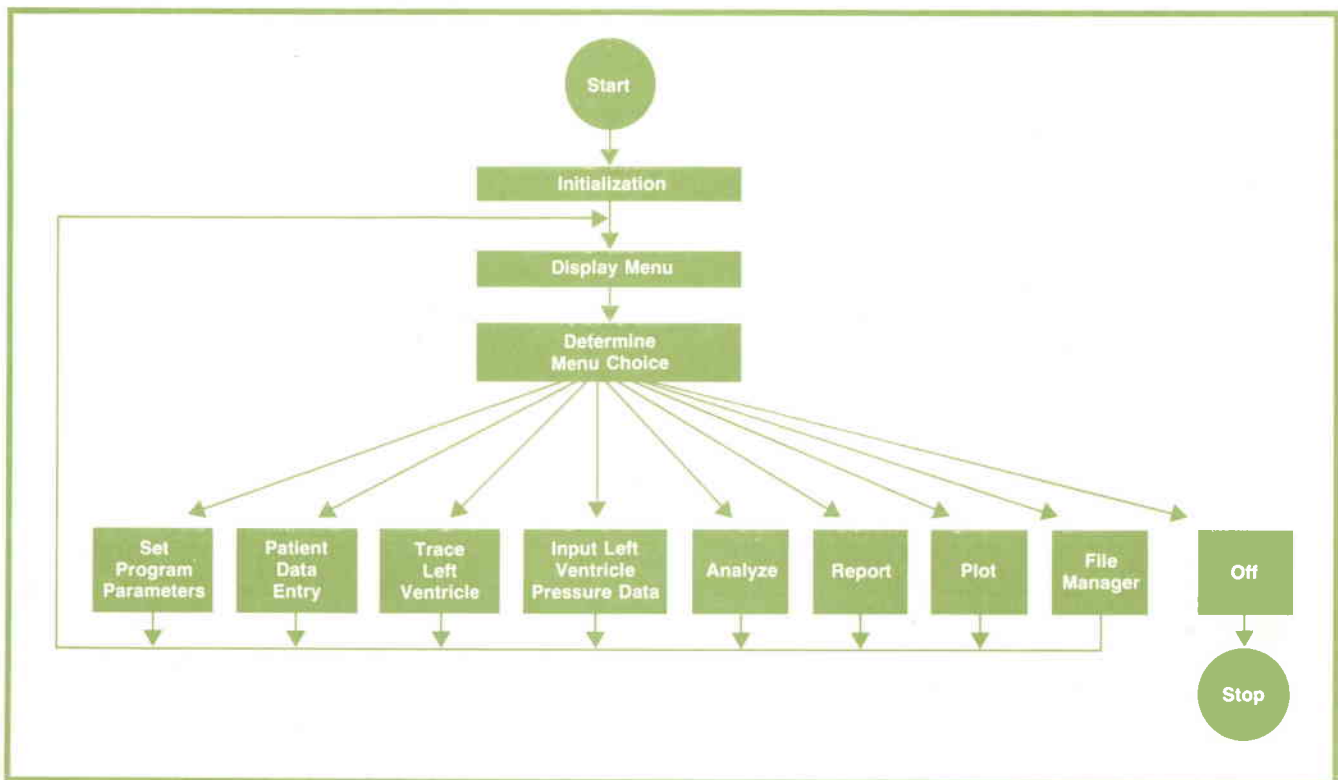

Fig. 6. Program organization allows program segments to be executed in any order.



Fig. 7. Each program segment (except off) returns to the "menu" display after completion.

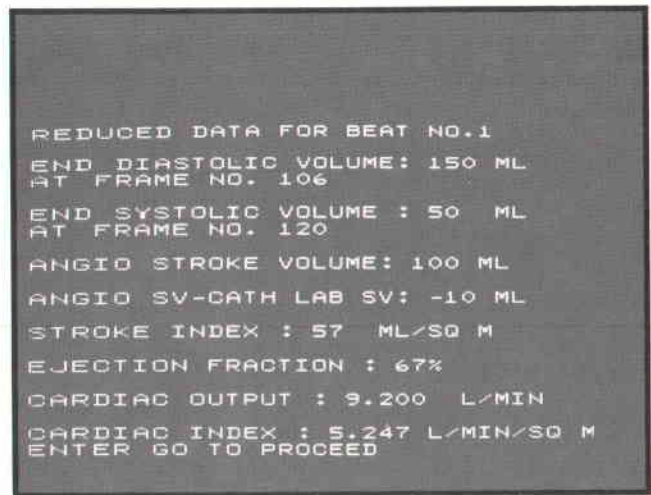

Fig. 9. Following entry of all tracings, computer analyzes results.

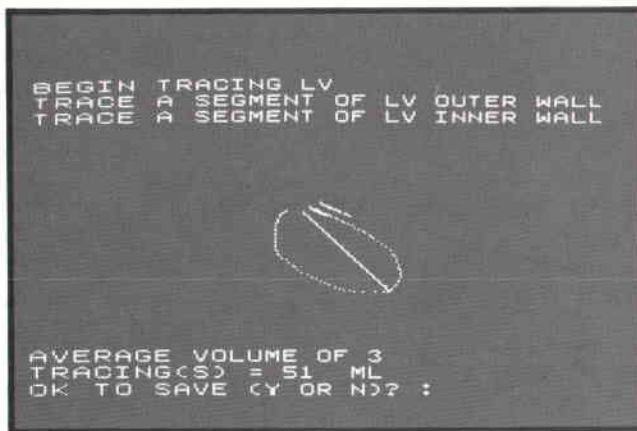

Fig. 8. When the physician indicates that a satisfactory tracing has been obtained, the computer calculates ventricular volume.

minimum necessary to tie all the parts together, and operation relates directly to presently used procedures, requiring a minimum of retraining for the medical personnel who would use it. Analysis that formerly required a full day of a physician's time may now be done in about 20 minutes, thus allowing the technique to be used routinely for clinical diagnosis.

Acknowledgments

The system has been evaluated in the Stanford University Hospital Cath Lab under the direction of Dr. Donald C. Harrison, Chief of the Cardiology Division and Dr. Edwin L. Alderman, Assistant Professor

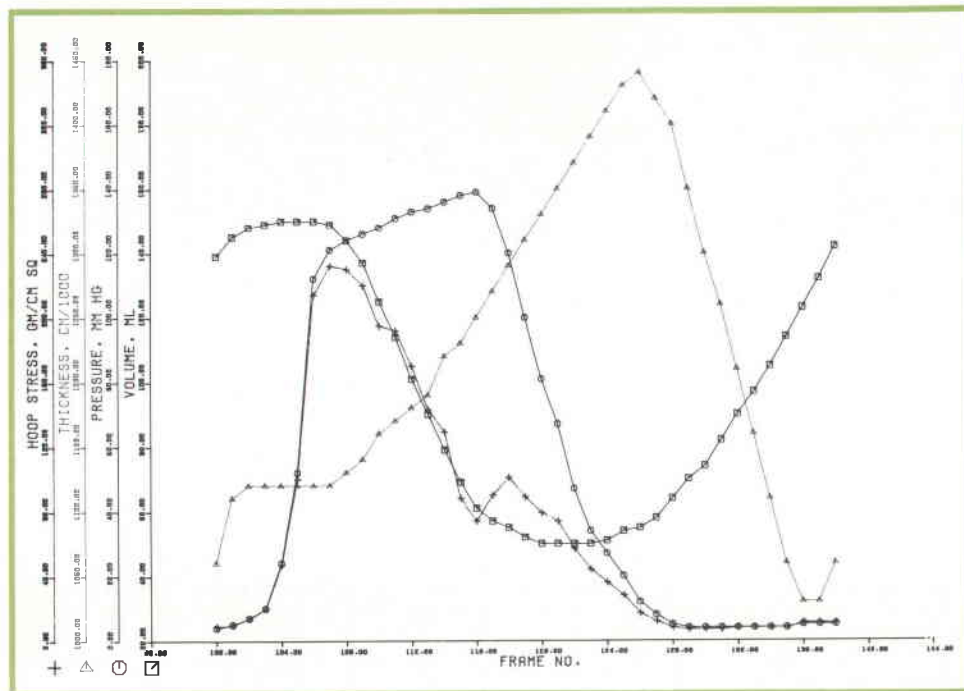



Fig. 10. On command, the computer can plot derived parameters like these plots of hoop stress, thickness, pressure, and volume versus time (frame number).

of Cardiology. During the course of the development Drs. Harrison and Alderman gave us many valuable suggestions which have contributed a great deal towards the success of this system. 

References

1. H.T. Dodge, H. Sandler, D.W. Badlew, J.D. Lord, Jr., "The Use of Biplane Angio-Cardiography for the Measurement of Left Ventricular Volume in Man," *American Heart Journal*, 60: 762, 1960.
2. C.B. Chapman, O. Baker, J. Reynolds, F.J. Ronte, "Use of Biplane Cinefluorography for Measurement of Ventricular Volume," *Circulation*, 18: 1105, 1958.
3. H. Sandler, R.R. Hawley, H.T. Dodge, W.A. Rexley, "Calculation of Left Ventricular Volume from Single Plane (A-P) Angiocardiogram," *Journal of Clinical Investigation*, 44: 1094, 1965.
4. J.L. Fanton, "A Computer-Aided Hospital System for Cardiac Catheterization Procedures," *HP Journal*, January 1972.



Peter Dikeman

Before joining Hewlett-Packard in 1972, Peter Dikeman spent three years at an aerospace firm doing logic design and programming for automatic test systems. He's a graduate of Swarthmore College in Pennsylvania where he earned his BSEE degree in 1969. A furniture-making woodworker when time permits, Peter and his wife enjoy cross-country skiing in the Adirondack mountains of eastern New York state and sailing in their 27-foot Catalina on Buzzards' Bay in south-eastern Massachusetts.

Chi-ning Liu

Chi-ning Liu did his undergraduate work at National Taiwan University, earned his MSEE at the University of Sydney (Australia) and his PhD at the Polytechnic Institute of Brooklyn (New York). He was a research physicist at the Commonwealth Acoustic Laboratories in Australia, designing ultrasound systems for visualizing internal organs, and a senior research fellow at the Polytechnic Institute of Brooklyn where he developed a model of the heart as a multipole generator of electric potentials. Since joining Hewlett-Packard in 1967, he has worked on computer systems for biomedical research and on-line patient care. A past vice-president of the Greater Boston Chinese Cultural Association, an organization that bridges eastern and western cultures, Chi-ning plays informal basketball games within that organization and he is an accomplished performer on Chinese string instruments. He and his wife have three daughters, ages 8, 4, and 1.

SPECIFICATIONS

HP Model 5693A Angio Analyzer

(an option to the Model 5690B Cardiac Catheterization Laboratory System)

PROJECTOR

FILM TYPE: 16 or 35 mm.

FILM ADVANCE: motion picture mode, 5 to 24 frames/s. Single frame advance.

Projector is equipped with frame counter.

MAGNIFICATION: approximately $\times 12.7$.

DIGITIZER

PRECISION/ACCURACY: < 0.25 mm.

RESOLUTION: 70 lines/in (28 lines/cm) at analog output

SAMPLE RATE: 1 to 200/s, variable.

PEN LIFE: 5×10^7 samples

POWER: 115V, optionally 230V, 50/60 Hz, 600W.

WEIGHT: 122 lbs (56 kg)

PRICE IN U.S.A.: 5693A option: \$17,000

5690B (typical installation): \$58,000

MANUFACTURING DIVISION: MEDICAL ELECTRONICS DIVISION

175 Wyman Street

Waltham, Massachusetts 02154

Hewlett-Packard Company, 1501 Page Mill
Road, Palo Alto, California 94304

Bulk Rate
U.S. Postage
Paid
Hewlett-Packard
Company

HEWLETT-PACKARD JOURNAL

APRIL 1974 Volume 25 • Number 8

Technical Information from the Laboratories of
Hewlett-Packard Company

Hewlett-Packard S.A., CH-1217 Meyrin 2
Geneva, Switzerland

Yokogawa-Hewlett-Packard Ltd., Shibuya-Ku
Tokyo 151 Japan

Editorial Director • Howard L. Roberts
Managing Editor • Richard P. Dolan
Contributing Editors • Ross H. Snyder,
Laurence D. Shergalls

Art Director, Photographer • Arvid A. Danielson
Art Assistant • Sue M. Reinheimer
Administrative Services • Anne S. LoPresti
European Production Manager • Kurt Hungerbühler

CHANGE OF ADDRESS : To change your address or delete your name from our mailing list please send us your old address label (it peels off). Send changes to Hewlett-Packard Journal, 1501 Page Mill Road, Palo Alto, California 94304 U.S.A. Allow 60 days.

HP Archive

This vintage Hewlett-Packard document was
preserved and distributed by

www.hparchive.com

Please visit us on the web!

On-line curator: John Miles, KE5FX

jmiles@pop.net

