

DECEMBER 1973

# HEWLETT-PACKARD JOURNAL

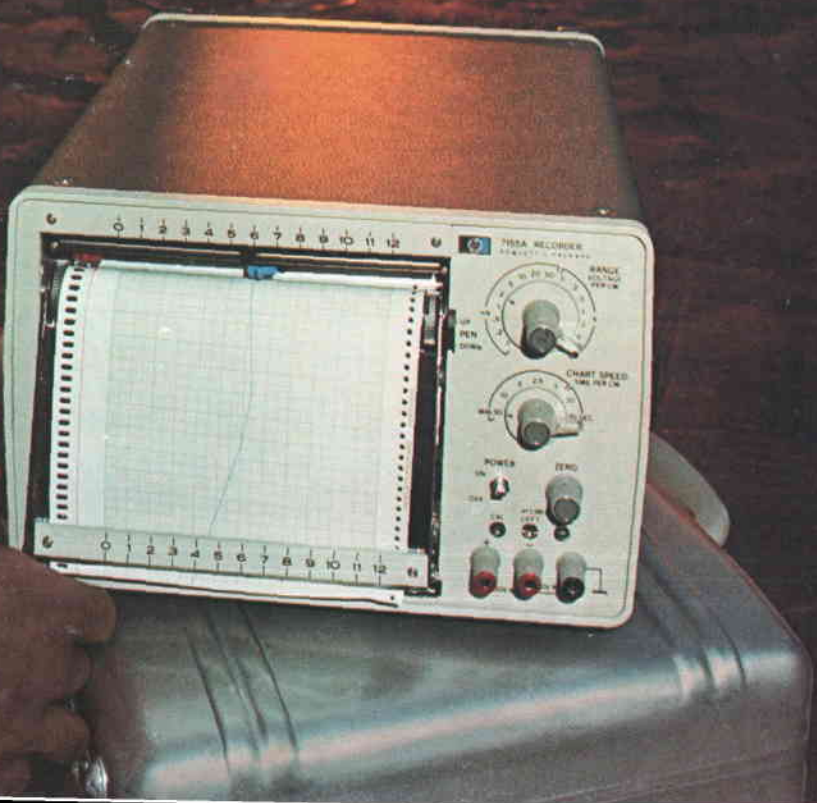
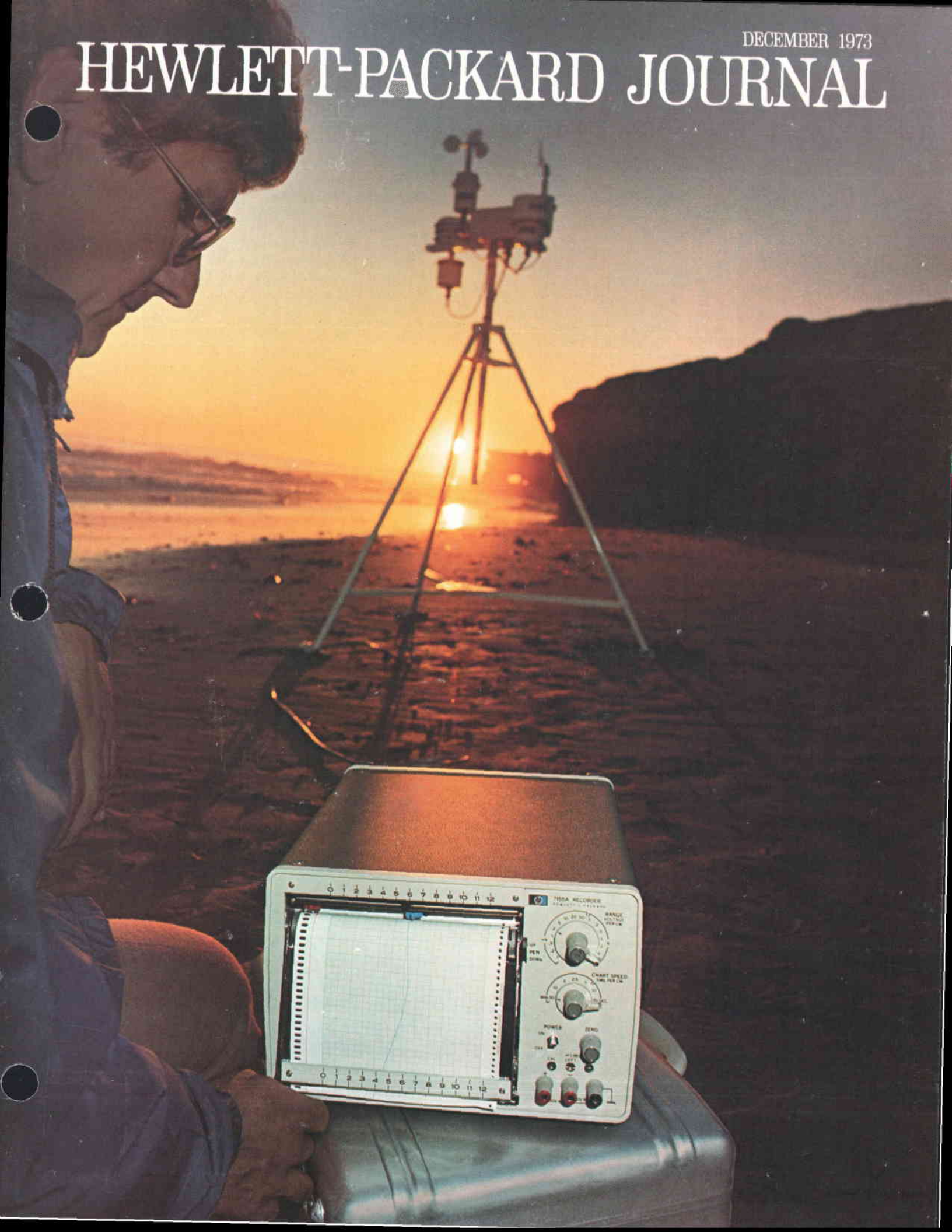

# A Go-Anywhere Strip-Chart Recorder That Has Laboratory Accuracy

*This rugged, portable recorder is designed to operate in the laboratory, in a moving vehicle or aircraft, in the desert, in freezing temperatures, on battery power or ac of various frequencies, even upside down, always within its laboratory specifications.*

by Howard L. Merrill and Rick A. Warp

**M**ONITORING A VOLTAGE representing some variable and producing a permanent graphic record of it as a function of time is the special job of the strip-chart recorder. These recorders come in many different types and sizes with capabilities to match nearly every application. However, there has long been a need for a strip-chart recorder that could deliver laboratory-accuracy recordings under relatively severe field conditions while operating on batteries or whatever power might be available.

Model 7155A Portable Strip-Chart Recorder, Fig. 1, was designed to fill this need. To our knowledge it is the first laboratory-quality strip-chart recorder that is also rugged and portable. Its specifications are guaranteed over a temperature range of  $-28^{\circ}\text{C}$  to  $+65^{\circ}\text{C}$  and under all conditions of humidity, shock, and vibration imposed by Hewlett-Packard class B environmental specifications.\* Typical instruments exceed the shock and vibration specifications by substantial margins.

The new recorder is accurate within  $\pm 0.5\%$  of full scale. Overshoot is less than 1% and deadband (a combination of backlash, turn-on voltages, and friction) is less than 0.2% of full scale. Chart speed is accurate within  $\pm 1\%$  and is independent of power-line frequency, so paper movement is equally accurate whether the recorder is operated in a laboratory, on 400 Hz power in an airplane, or on power from an auxiliary generator whose frequency is uncontrolled. Common-mode rejection of the floating, differential input amplifier is greater than 120 dB at dc and greater than 100 dB at 50 or 60 Hz.

Depending on what power option is selected (see specifications) the new recorder can operate on external ac, external dc, or internal rechargeable batteries. Ac power can be 115 or 230 volts, 48 to 440

\*Relative humidity: five 24-hr cycles to 95% at  $40^{\circ}\text{C}$ . Shock: 30g. Vibration: 10-55 Hz, 0.010 inch peak-to-peak deviation.

Hz. External dc can be 10.5 to 34 volts. The internal batteries recharge while the recorder is operating on ac power.

The recorder package is a modified version of the one used for HP 1700-Series Portable Oscilloscopes.<sup>1</sup> For maximum ruggedness, most parts of the recorder are rigidly attached to the front and rear castings of the case. This creates a rigid base for the instrument without incurring high tooling costs.



**Cover:** *The new Model 7155A Portable Strip-Chart Recorder takes remote sites, rugged terrain, and un-laboratorylike environments in its stride. It can't quite match the automatic weather station on our cover when it comes to enduring severe weather without special protection, but it'll help check things out after the storm is over. (The weather station is from Towner Systems of San Leandro, California.)*

## In this Issue:

*A Go-Anywhere Strip-Chart Recorder That Has Laboratory Accuracy, by Howard L. Merrill and Rick A. Warp* **page 2**

*Telecommunication Cable Fault Location from the Test Desk, by Thomas R. Graham and James M. Hood . . . . .* **page 9**

*High-Efficiency Modular Power Supplies Using Switching Regulators, by B. William Dudley and Robert D. Peck* **page 15**

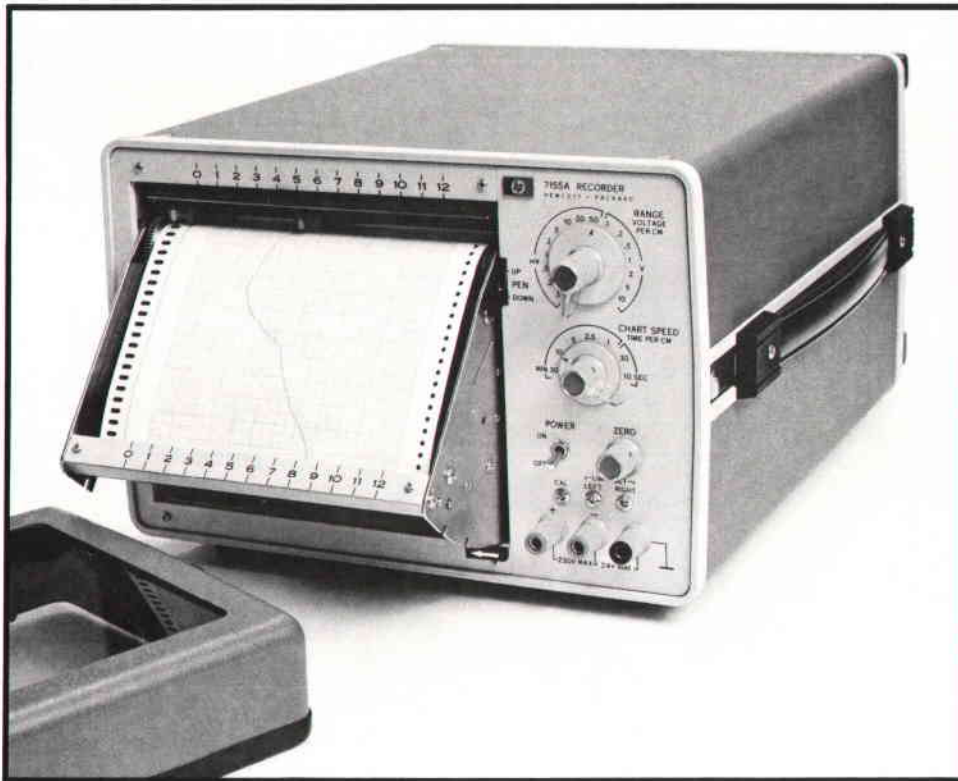

**Fig. 1.** Model 7155A Portable Strip-Chart Recorder is designed to deliver laboratory accuracy in field use. Pen displacement is accurate within  $\pm 0.5\%$  and chart speed is accurate within  $\pm 1\%$ , independent of ac line frequency, over a wide range of environmental conditions. Internal batteries are optional.

Disposable fiber-tip pens, insensitive to attitude changes or fluid forces caused by acceleration, are used in the new recorder. The ink is red or blue and is specially formulated so the pens will write reliably over the entire  $-28^{\circ}\text{C}$  to  $+65^{\circ}\text{C}$  temperature range. The trace dries instantly at any writing or chart speed.

#### The Writing System

Internally, the 7155A consists of two major systems, the writing system and the power supplies. The writing system is composed of a chopper-stabilized differential input amplifier, an accurate servo system, a reliable stepper-motor chart drive, and the disposable-ink system, all guaranteed to operate at temperatures from  $-28^{\circ}\text{C}$  to  $+65^{\circ}\text{C}$  and through five cycles of relative humidity to 95% at  $40^{\circ}\text{C}$ .

#### Dc Preampifier

Considering possible approaches to the design of a stable dc preamplifier for a recorder such as this, the designers asked themselves, "Can the desirability of low cost justify the use of direct-coupled amplifier stages even though these inherently have greater drift?" Because of the wide operating temperature range of the 7155A, the answer to this question had to be, "No."

The next approach considered was to use a number of ac-coupled gain stages preceded by a chopper type of modulator and followed by a

switching demodulator and a low-pass filter, as shown in Fig. 2a. This design has been used successfully in other recorder preamplifiers, but its cost wasn't compatible with 7155A cost objectives. Because semiconductor choppers vary in efficiency, and any such variation would appear as an error in the preamplifier output, the chopper would have to be mechanical and the transformer would need high input inductance. These two components alone would have raised the selling price of the instrument by more than 10%.

The approach chosen, shown in Fig. 2b, has also been used in other recorders. Its advantage is that it uses a semiconductor chopper, but the varying chopper efficiency affects only the internal loop gain of the preamplifier. The preamplifier output remains stable at the gain level determined by the feedback resistors.

The preamplifier and servo system float with respect to the case of the recorder, which is grounded. The preamplifier acts as a differential amplifier and responds only to the difference in the voltage applied to its two floating inputs. Any voltage common to both inputs, such as hum pickup in the input leads or the constant voltage on the outputs of a resistive bridge, will be rejected.

#### Servo System

The pen-positioning servo system consists of a reference voltage, a feedback potentiometer that indicates pen position, an error amplifier that com-

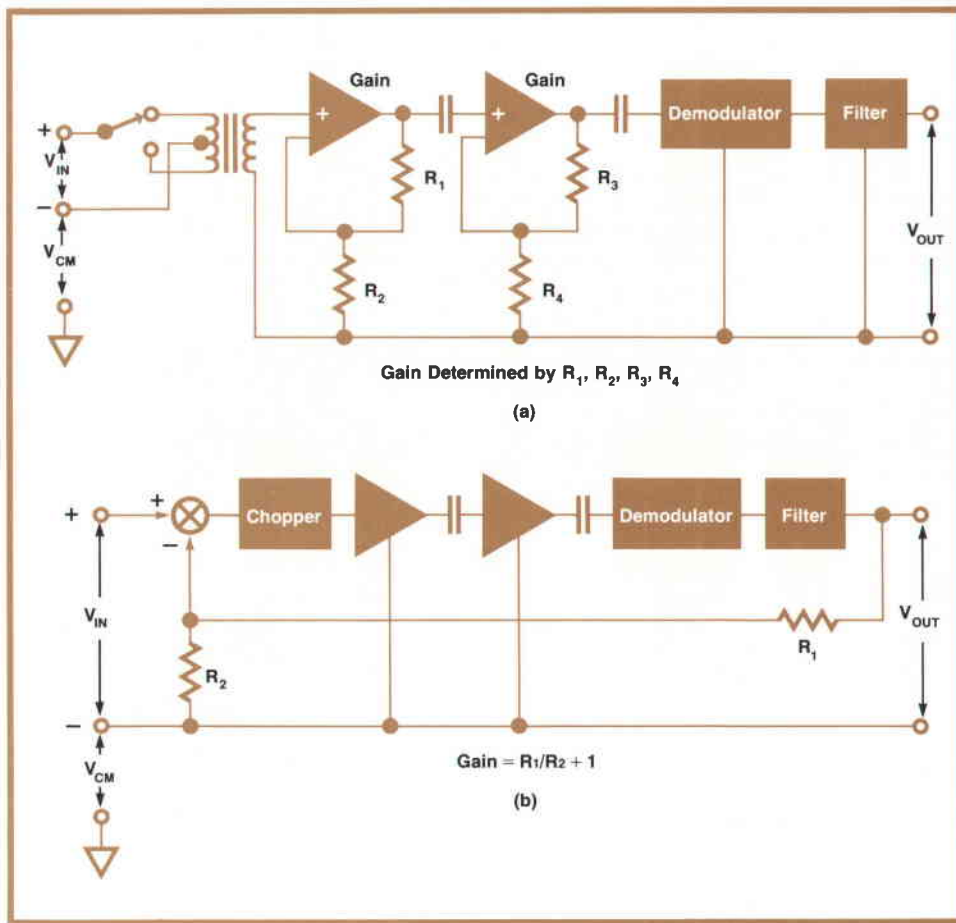

Fig. 2. Dc preamplifier stabilized by a mechanical chopper, as shown in (a), is used in other recorders, but was judged too costly for the 7155A. The 7155A input amplifier, shown in (b), uses a semiconductor chopper, but the design makes the output independent of chopper efficiency. Common mode rejection of the floating differential input is greater than 120 dB at dc, 100 dB at 50 or 60 Hz.

compares the actual pen position to the desired pen position (the preamplifier output), a power amplifier driving a dc motor and a belt/cable system that moves the pen, and two compensation networks. Fig. 3 is a diagram of the system.

The open-loop transfer function of the servo system consists basically of the transfer function of a dc motor with a constant field and the input voltage

applied to the armature, along with a constant representing the gain of the amplifiers and the pulley reduction between the motor and the pen. Thus

$$T = K_t / [s(JR_s + K_v K_t)]$$

where  $K_t$  is a torque constant representing the amount of torque produced for a given armature cur-

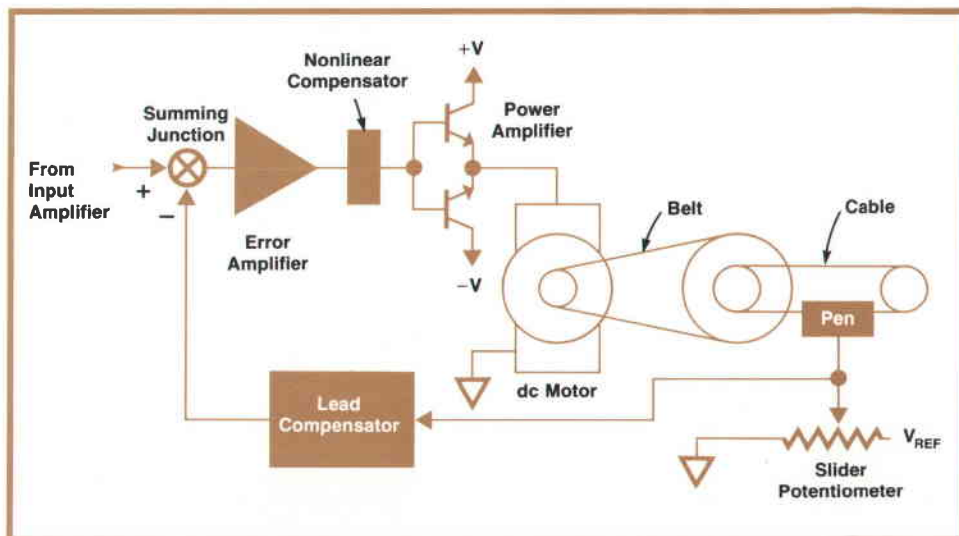
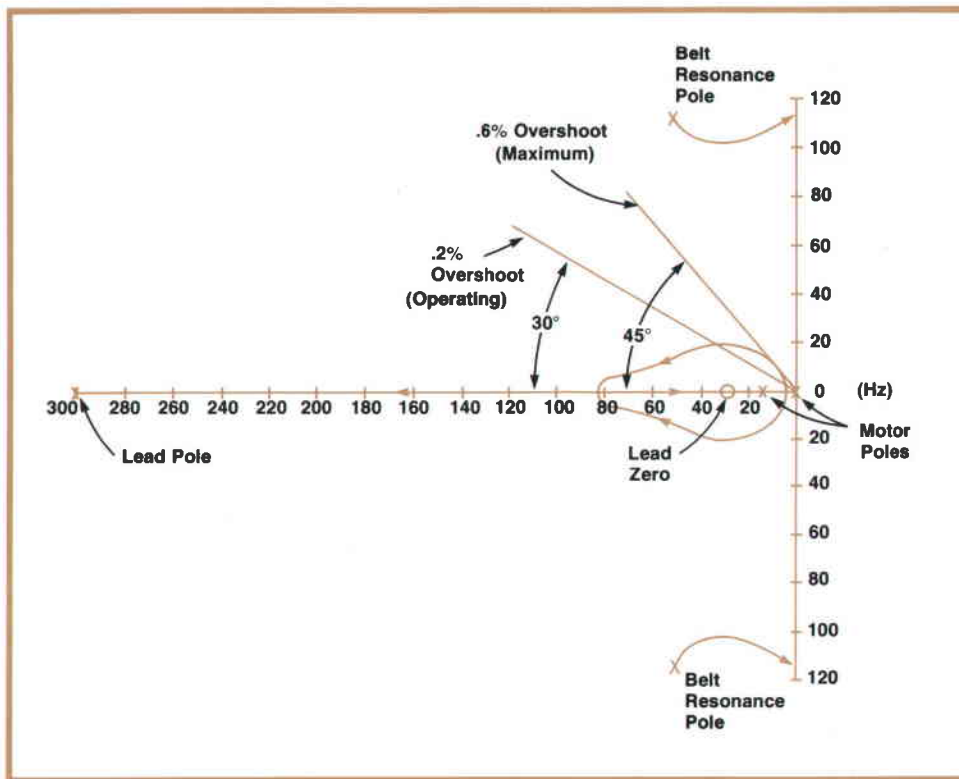

Fig. 3. Slider-potentiometer provides pen-position information for the servo system. Pens are disposable fiber-tip type, insensitive to attitude and acceleration, and the ink is specially formulated to write from  $-28^\circ\text{C}$  to  $+65^\circ\text{C}$ .



**Fig. 4.** Root-locus plot of the positioning servo system shows that the operating loop gain results in poles that have less than maximum overshoot but are still off the real axis. This results in the fastest possible response consistent with adequate gain margin for the belt resonance poles.

rent,  $J$  is the rotational moment of inertia of the system reflected at the motor,  $R$  is the motor armature resistance, and  $K_v$  is a velocity constant representing the back voltage for a given angular velocity of the motor shaft. To this basic transfer function must be added a pair of complex poles describing the resonance characteristics of the pen, pulley, and motor inertial masses and the characteristics of the belt, and a pole and a zero representing the feedback compensating network.

The resulting pole-zero configuration and the root-locus plot of the system are shown in Fig. 4. The complex poles near the origin dominate the response, and the theoretical maximum overshoot is 0.6%. The root-locus plot shows that the operating point chosen has less overshoot than the theoretical maximum but is still off the real axis. This was done to assure an adequate gain margin for the resonance poles of the mechanical components while maintaining as fast a response as possible.

At this operating point, however, the gain is insufficient to achieve the required deadband specification. Therefore, a nonlinear compensator makes the small-signal gain of the system higher than the large-signal gain, as shown by the Bode diagrams, Fig. 5. The transition from small-signal to large-signal characteristics is determined by the turn-on voltage of a string of diodes, a voltage approximately equal to the starting voltage of the system measured at the servo motor armature. The actual starting voltage, or deadband, at any time may be greater than

or less than the diode turn-on voltage, but this will not affect the stability of the system or the large-signal step response.

#### Chart Drive

The chart drive design is shown in Fig. 6. A 440 Hz Wien-bridge oscillator with automatic gain control provides a reference frequency that is divided by a programmable integrated-circuit divider and applied to a stepper chart-drive motor.

The oscillator makes the chart drive accuracy independent of the power line frequency, and makes it possible to operate on dc power. Using a stepper motor instead of a synchronous motor eliminates the need for a mechanical transmission to provide different chart speeds. It also substantially increases reliability and reduces cost.

#### Fiber-tip Pens

The disposable fiber-tip pens are made of polypropylene and filled with a compressed bundle of oriented polyester fibers. The ink injected into the fiber bundle is insensitive to gravitational or inertial effects because of the large capillary forces drawing it towards the polyester pen tip.

#### Power Supplies

An overall block diagram of the new recorder's power system is shown in Fig. 7. The internal battery is a sealed, 12 volt, gelled-electrolyte, lead-acid battery. In spite of the fact that its specific energy ca-

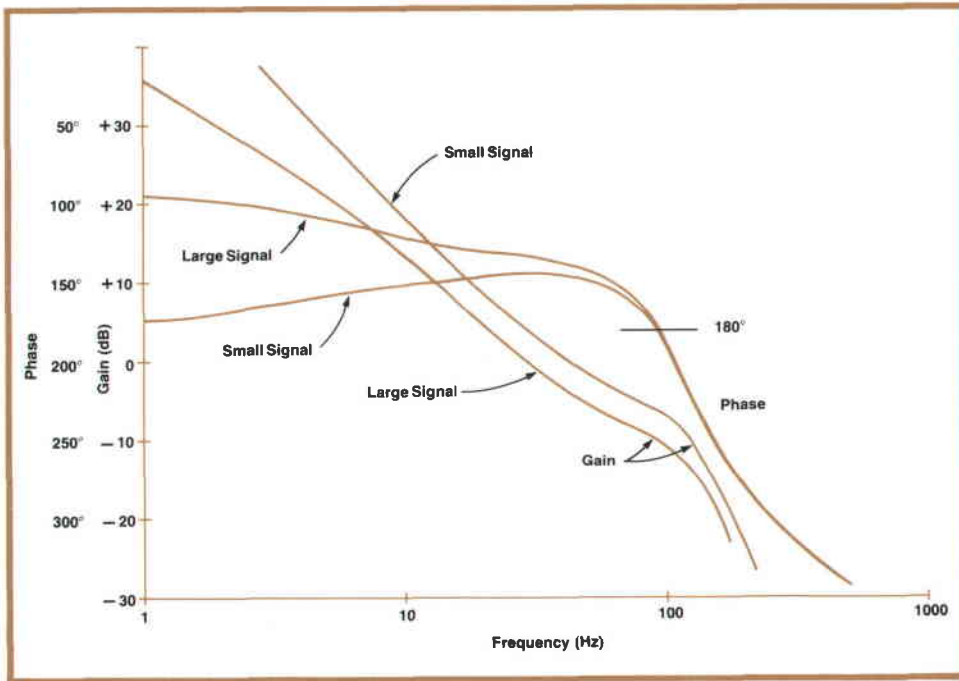

**Fig. 5.** To achieve the specified deadband of less than 0.2% of full scale, a nonlinear compensator was included in the servo system to increase the loop gain for small signals, as these Bode plots show.

capacity (energy stored per unit volume) is about 30% less than that of nickel-cadmium or other high-performance batteries, the economy of the lead-acid battery, its lack of the long-term memory effects\* that are common in nickel-cadmium batteries, and its wide operating temperature range make this type of battery very attractive for this application. The recorder will operate approximately nine hours at 20°C before the batteries need recharging.

\*Temporary loss of capacity due to repetitive partial discharge cycles.

The ac rectifier and the +10V regulator are of standard design. The regulator is a series type.

The battery charger consists of a current-limited 13.8V supply that is connected across the battery terminals whenever the recorder is plugged into the ac line. The maximum charging current available is 1.2A. This "float charger" allows the battery to be charged whenever ac power is available. It also makes possible a standby mode of operation, wherein the instrument is plugged into the ac line and set

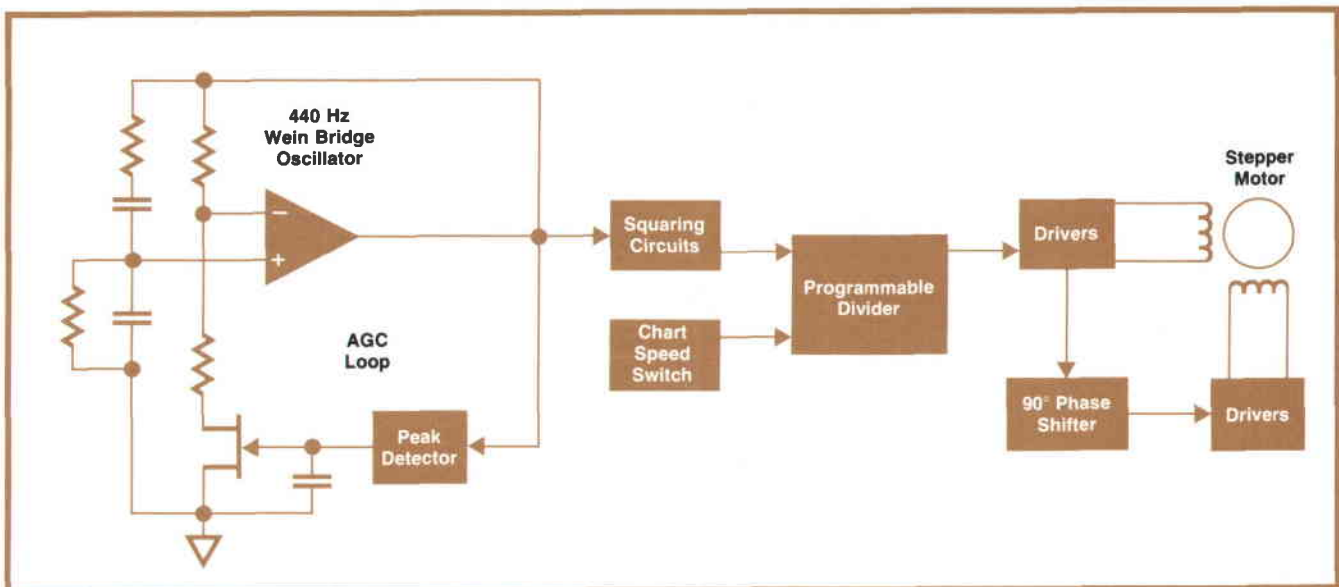

**Fig. 6.** Chart drive motor is a stepper motor driven by a Wien bridge oscillator with AGC. Seven chart speeds are derived by dividing the oscillator frequency. No mechanical transmission is needed. The oscillator makes chart speed independent of power line frequency and makes battery operation possible.

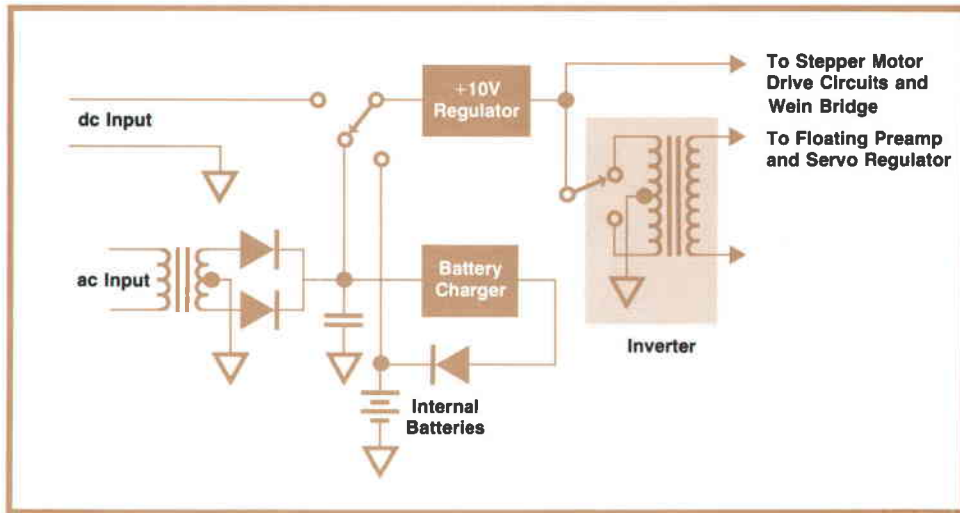

**Fig. 7.** Internal batteries are gelled-electrolyte lead-acid batteries capable of operating in any position and having no long-term memory effects. Recorder operates 9 hours at 20°C without recharging. Ac power supplies are of standard design.

to the battery position (see rear-panel view, Fig. 8). The charger is capable of charging the batteries and operating the recorder simultaneously. If the ac power should fail, the recorder will keep operating for up to nine hours on its internal battery. When the ac power is restored, the battery will then recharge.

The battery charger has a current sensor on its output (a 0.5Ω resistor and a comparator). This circuit turns on a “battery charging” light when the current into the battery is greater than 50 mA.

**Other Features and Options**

Other features of the 7155A Recorder include a

transparent plastic front cover to keep out dust and dirt, three chart-magazine tilt angles, and easy access to the internal printed-circuit boards for servicing.

Among the options are left and right limit switches positioned by screwdriver adjustment from the front panel, both adjustable over the full recording span. An optional notch filter reduces unwanted input noises, and an optional 5 kΩ retransmitting potentiometer provides true pen-position output information. Other options include right-hand zero, metric scaling, and a remotely controlled event marker.

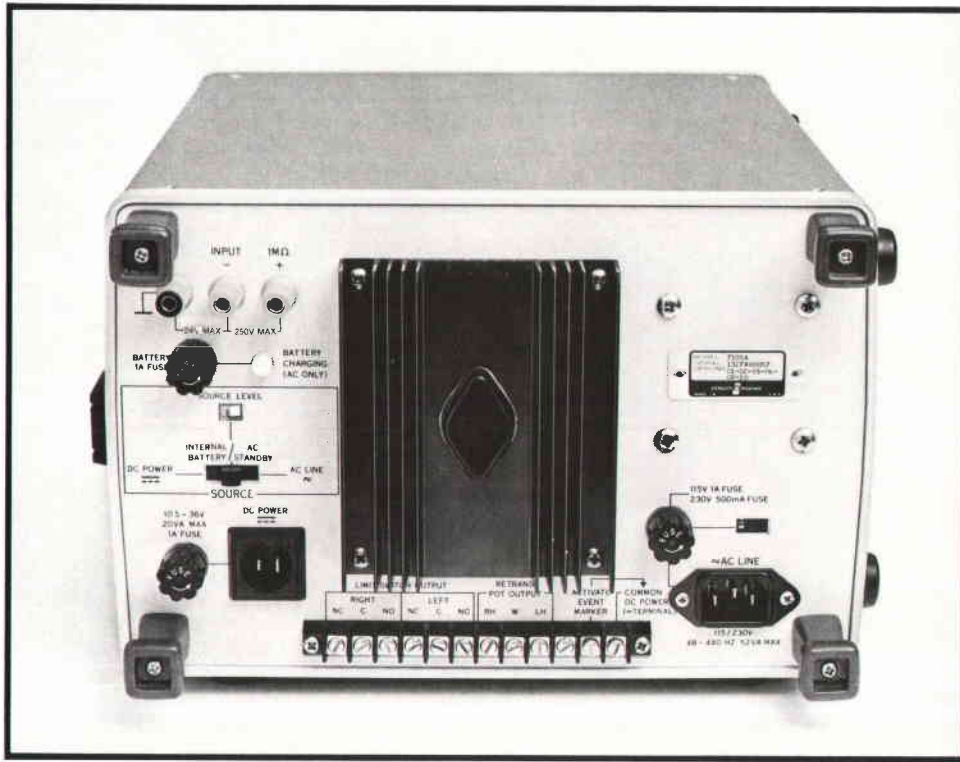

**Fig. 8.** Battery charger is connected across the internal batteries whenever the recorder is plugged into the ac line. When the rear-panel source switch is in the battery/standby position, ac power can be used and the recorder will switch to battery power if the ac power fails.

## Acknowledgments

Many people contributed to the development of this recorder. Jim Follansbee and Paul Freda were the original electrical engineers and Dick Weddleton was the original mechanical engineer. Product designer was Glen Passmore and tooling was by Tom Young. The disposable-pen writing system was developed by Dale Davis. Group leaders Larry Brunetti and Ron Norton provided much encouragement and advice. 📄

## SPECIFICATIONS

### HP Model 7155A Recorder

#### Performance Specifications

**INPUT RANGES:** .1mV/div thru 10V/div in 1,2,5 steps with overlapping vernier (10 div/full scale).

**TYPE OF INPUT:** Single-ended, floating.

**INPUT RESISTANCE:** 1M $\Omega$  constant on all spans.

**MAXIMUM ALLOWABLE SOURCE RESISTANCE:** 5k $\Omega$  for rated response and accuracy.

**NORMAL MODE REJECTION:** 25 dB (65 dB with filter, Option 004) at 50 Hz or 60 Hz.

**COMMON MODE REJECTION:** 120 dB at dc; 100 dB at ac 50/60 Hz.

**RESPONSE TIME:** 0.5 seconds full scale to within rated accuracy.

**OVERSHOOT:** 1% of full scale (maximum).

**ACCURACY OF DEFLECTION (at 25°C):**  $\pm 0.5\%$  of full scale (includes dead-band and linearity).

Temperature coefficient: 0.02%/°C.

**RANGE-TO-RANGE ACCURACY:**  $\pm 0.3\%$  of full scale.

**LINEARITY:** 0.25% full scale (terminal based).

**ZERO:** Full span adjustment.

**CHART SPEEDS:** 20 seconds/inch, 1,2,5,10,20,60 minutes/inch.

**CHART SPEED ACCURACY:** 1% cumulative.

**ENVIRONMENTAL (OPERATING):** -28°C to +65°C <95% relative humidity (40°C).

#### General Specifications

**WRITING MECHANISM:** Servo actuated ink pens (wide temperature disposable pens).

**GRID WIDTH:** 5 inches (12 cm).

**CHART LENGTH:** 70 ft (21.3 m).

**PEN LIFT:** Mechanical.

**WEIGHT:** Net, 30 lbs (13.64 kg) with battery option.

#### POWER SOURCES:

**OPTION 007 - External ac** (48 to 440 Hz, 115  $\pm 10\%$  or 230  $\pm 10\%$  V); 30VA max.; External dc (10.5 to 36V, 0.5 amp typ.; 0.9 amp max. independent of voltage).

**OPTION 008 - External ac, External dc, Internal rechargeable batteries** (recharge while operating).

**OPTION 009 - External dc** (10.5 to 34V, 0.5 amp typ.; 0.9 amp max. independent of voltage).

**NOTE:** Power option must be specified when ordering instrument.

**PRICE IN U.S.A.:** \$985 (Power Options 007 and 008 additional).

#### Options

**METRIC SCALING:** Option 001 - N/C

**SPAN:** .1mV/cm thru 10V/cm in 1,2,5 steps with overlapping vernier (12 cm full scale).

**SPEEDS:** 30, 10, 5, 2.5, 1 minute/cm; 30, 10 seconds/cm.

**LIMIT SWITCHES:** Option 002 - \$100

**RETRANSMITTING POTENTIOMETER (5k $\Omega$ ):** Option 003 - \$75

**FILTER 65 dB NMR, response time 1 sec f.s.:** Option 004 - \$25

**RIGHT HAND ZERO:** Option 005 - N/C

**EVENT MARKER:** Option 006 - \$75

**EXTERNAL AC AND DC:** Option 007 - \$40

**EXTERNAL AC, DC, AND BATTERY:** Option 008 - \$150

**EXTERNAL DC:** Option 009 - N/C

**DELETE FRONT COVER:** Option 010 - less \$25

**MANUFACTURING DIVISION:** SAN DIEGO DIVISION  
16399 West Bernardo Drive  
San Diego, California 92127 U.S.A.

## Reference

1. T.K. Bohley, R.E. Mast, and D.R. Bloyer, "A Power-Thrifty Portable Oscilloscope," Hewlett-Packard Journal, May 1971.

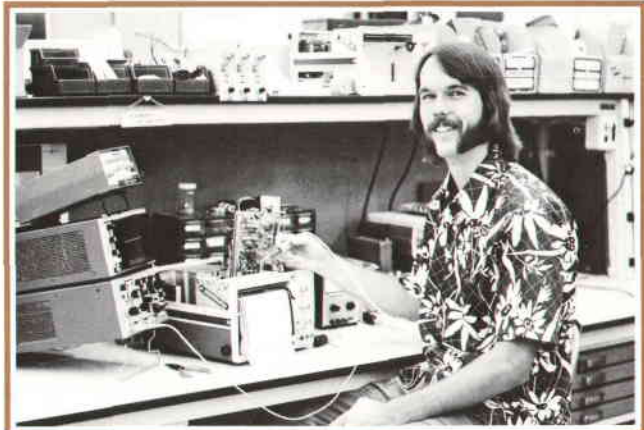

### Rick A. Warp

Rick (it's not a nickname) Warp did the mechanical design of the 7155A Recorder. Born in Tacoma, Washington, Rick came to California to attend Stanford University. He received his BSME and MSME degrees in 1971, then continued his southward migration to join HP's San Diego Division. He's a member of ASME. The creative process intrigues him, and he once served as a teaching assistant in a course on "visual thinking" Away from the job, Rick can often be found playing tennis, riding his bicycle, or playing guitar (he plays both folk and classical). Rick and his wife live in San Diego.



### Howard L. Merrill

Howard Merrill joined HP following his graduation from California Polytechnic College in Pomona, California where he received his BS degree in 1970. Howard's responsibilities with HP have included development of the 17400A High Gain DC Preamplifier plug-in for the 7402A Oscillographic Recorder and project leadership for the 7155A Portable Strip-Chart Recorder. One of Howard's major interests is music. He plays the piano and is a student of both modern dance and folk dancing. Backpacking also qualifies as a major interest. Howard makes his home near the beach in La Jolla, California.

# Telecommunication Cable Fault Location from the Test Desk

*This new fault locator automates Wheatstone-bridge methods that have fallen into disuse because they are too cumbersome. The result is fast, easy fault location and better telephone service.*

by Thomas R. Graham and James M. Hood

**I**F YOU HEAR VOICES from other conversations while using your telephone it may be crosstalk caused by moisture that has formed a conductive path between wires in the telephone cable. If there's a high noise level on your line, it may be the result of leakage between a wire and ground.

Model 4913A Test Desk Fault Locator, Fig. 1, is designed to locate faults like these quickly and easily. Its 3½-digit light-emitting diode display indicates the distance in feet from the instrument to the fault, from the instrument to the end of the cable, or from the end of the cable to the fault.

The 4913A will locate resistance paths between the wires of a pair (shorts), resistance paths between wires of two different pairs (crosses), and resistance paths between a wire and ground (grounds). Grounds and crosses can be located using only the faulty pair. Locating shorts requires one good pair in addition to the faulty pair. Under most conditions, the 4913A will locate faults that have resistances as high as 10MΩ, its sensitivity increasing as the fault resistance decreases (see Appendix). Thus the instrument can detect even faults that are unnoticeable to the telephone user.

## Role of the Test Desk

A local test desk is a test station located in a telephone company's local service center or repair service bureau. The local test desk uses dedicated test trunks to central offices to access customer lines. One repair service bureau can service several central offices. A simplified interconnection is shown in Fig. 2.

Trouble reports normally originate in the service bureau from subscriber complaints, routine tests, or acceptance tests. Fault location then proceeds in six steps. First, the fault is isolated to the cable or to other equipment such as the switching equipment

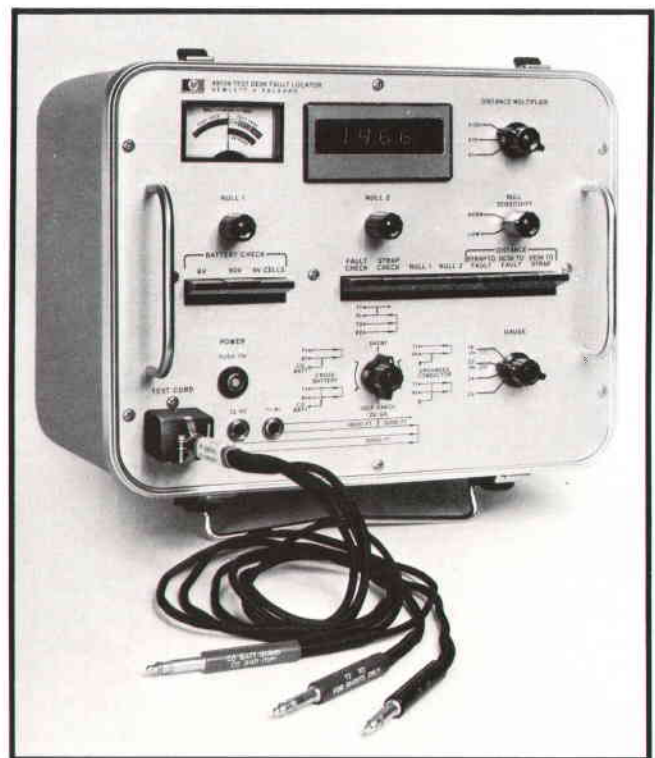

**Fig. 1.** Model 4913A Test Desk Fault Locator quickly locates shorts, crosses, and grounds without requiring special training. Piano-key switches are used in left-to-right sequence.

or subscriber set. Next, the fault is classified as to type.

The fault is then sectionalized, which means that its location is determined as accurately as possible from the local test desk. (Wire parameter tolerances, instrument accuracy tolerances, and difficulty in measuring cable lengths in the field prevent pinpointing faults from the local test desk.) This is the job of the 4913A.

The final three steps are performed in the field. The fault is localized from the cable access closest

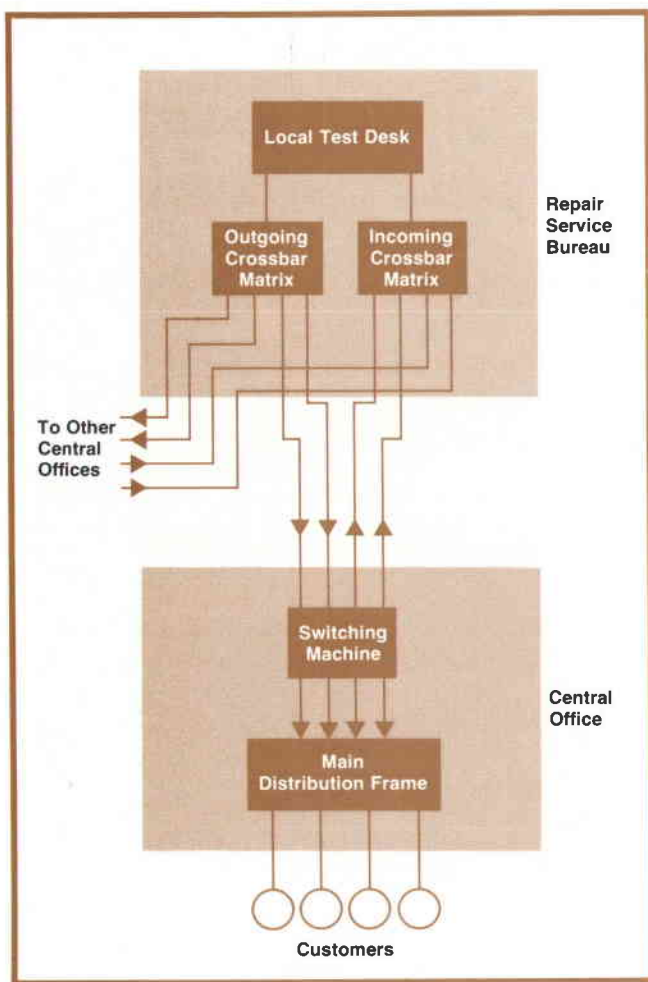

Fig. 2. 4913A Test Desk Fault Locator is designed for use at a local test desk in a telephone company repair service bureau. Faults are typically in customer lines originating in central offices. The test desk operator works with a craftsman in the field, e.g., at the customer location.

to the fault with another type of fault locator. The fault is then pinpointed by visual inspection or other means and repaired. The final step is verifying that all faults and their causes have been cleared.

### The Old Way

Fault sectionalization from the test desk is not a new idea. For years Wheatstone bridges have been present on some test desks for this purpose. The test desk operator works with a craftsman in the field. With the fault between the central office and the craftsman, a pair of wires free from faults is identified and shorted by the craftsman to one side of the faulted pair (Fig. 3). The test desk operator nulls the galvanometer, G, and records the resistance reading, V, for each of the three switch positions. This procedure is known as the three-Varley method. The following calculations must then be performed to obtain  $R_Y$ ,  $R_X$ , and  $R_T$ .

$$R_Y = \frac{A}{A + B} (V_2 - V_1) \text{ ohms} \quad (1)$$

$$R_X = \frac{A}{A + B} (V_3 - V_2) \text{ ohms} \quad (2)$$

$$R_T = \frac{A}{A + B} (V_3 - V_1) \text{ ohms} \quad (3)$$

Distances are then calculated by multiplying  $R_Y$ ,  $R_X$ , or  $R_T$  by an ohms-to-feet conversion factor determined by the wire gauge. The strap-to-fault distance, represented by  $R_Y$ , is usually the most important parameter. A typical faulted pair could be 35,000 feet long with the fault located 1500 feet from the far end.

A problem with this method of fault location is that the calculations are time consuming and the method requires an experienced operator. Also, the bridges lack the sensitivity to locate very-high-resistance faults resulting from wet plastic-insulated cable. When higher currents are used to compensate for this lack of sensitivity, faults are often dried out before they can be located. Because of these disadvantages Wheatstone bridges are not included in new test desks.

### The 4913A Way

The 4913A digital readout of the distances represented by equations 1, 2, and 3 can be obtained in seconds. The time consuming process of recording three different resistance values, calculating  $R_Y$ ,  $R_X$ , and  $R_T$ , and multiplying by an ohms-to-feet conversion factor has been eliminated.

First a craftsman at the customer station or other access point establishes communication with the test desk and makes a strap, depending on the type of fault. For shorts an extra good pair of wires is strapped to one wire of the faulted pair. For crosses and grounds only the faulted pair is strapped. At the test desk, connections to the faulty pair, good pair (if needed), battery, and ground are made, using the 4913A's 310-type telephone plugs.

Next, the fault mode switch (Fig. 4) is set according to the type of fault and the gauge switch is set to the proper wire gauge. When a cable consists of more than one gauge, that of the wire at the far end is chosen first because experience has shown that the fault is most likely to be found in the end section. This procedure gives an accurate strap-to-fault distance reading. If it turns out that the fault is in the gauge section closest to the test desk, changing the gauge switch to that gauge will give an accurate desk-to-fault distance reading. If the fault lies beyond a gauge-change point from both the strap and the test desk, a correction factor must be applied to get the correct reading.

The following steps are then taken, using the

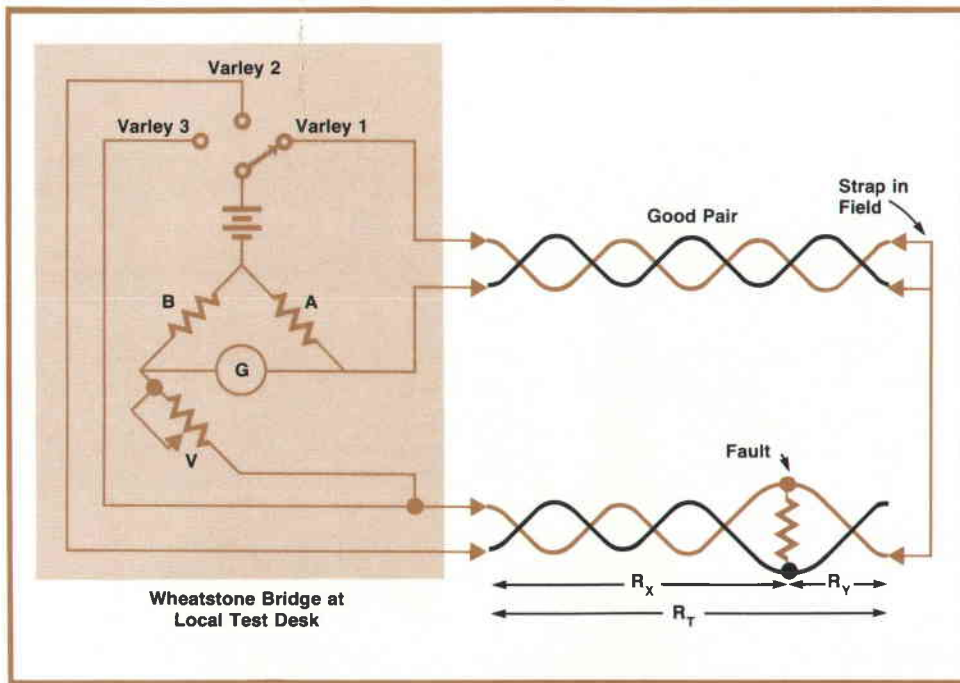

Fig. 3. Old three-Varley method required the test desk operator to make three Wheatstone-bridge nulls and calculate the distances represented by  $R_X$ ,  $R_Y$ , and  $R_T$ .

front-panel piano-key switches in left-to-right sequence.

- BATTERY CHECK
- FAULT CHECK: An analysis of the cable is made automatically to determine whether the fault still exists or has dried out.
- STRAP CHECK: The strap connections are verified automatically to assure a valid measurement.
- NULL 1: Dc voltage on the faulty pair is bucked out so it doesn't interfere with the measurement.
- NULL 2: The bridge circuits are balanced by adjusting the NULL knob so the computation circuits can compare the bridge ratio to the strap distance.
- FAULT DIST FROM STRAP: Distance to the fault

back from the strap is displayed.

- FAULT DIST FROM DESK: Distance to the fault from the desk is displayed.
- DIST DESK TO STRAP: Distance from the desk to the strap is displayed.

#### Null Operation

There are two sequential nulls. Null 1 (see Fig. 5) is a dc zero adjustment to cancel offsets from thermal voltages and loop voltage in the faulted wire caused by multiple faults. For example, a resistance path to the telephone company's -48 Vdc battery combined with a resistance path to ground generates the series voltage shown as  $V_{os}$  in Fig. 5. The Wheatstone bridges formerly used at the local test desk give incorrect readings when  $V_{os}$  is present in the faulted wire. In the 4913A, the internal dc offset generators of IC1 are adjusted to cancel  $V_{os}$ .

After Null 2 (Fig. 5) has been adjusted the circuit is a balanced Wheatstone bridge and equation 4 applies.

$$\frac{R_C}{R_X} = \frac{R_A + R_B}{R_Y + k(R_X + R_Y)} \quad (4)$$

$R_X$  is one arm of the bridge and  $R_Y + k(R_X + R_Y)$  is the other unknown arm. The coefficient  $k$  is an imbalance factor representing a good pair of wires that is different in length or gauge from the faulted pair.

#### Distance Readouts

The distance in feet from the strap to the fault, from the local test desk to the fault, or from the local test desk to the strap can now be displayed by pressing the appropriate switch.

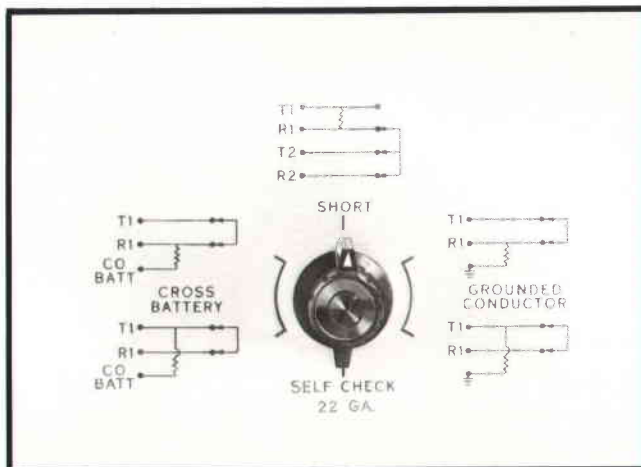

Fig. 4. 4913A fault mode switch is set to the type of fault.

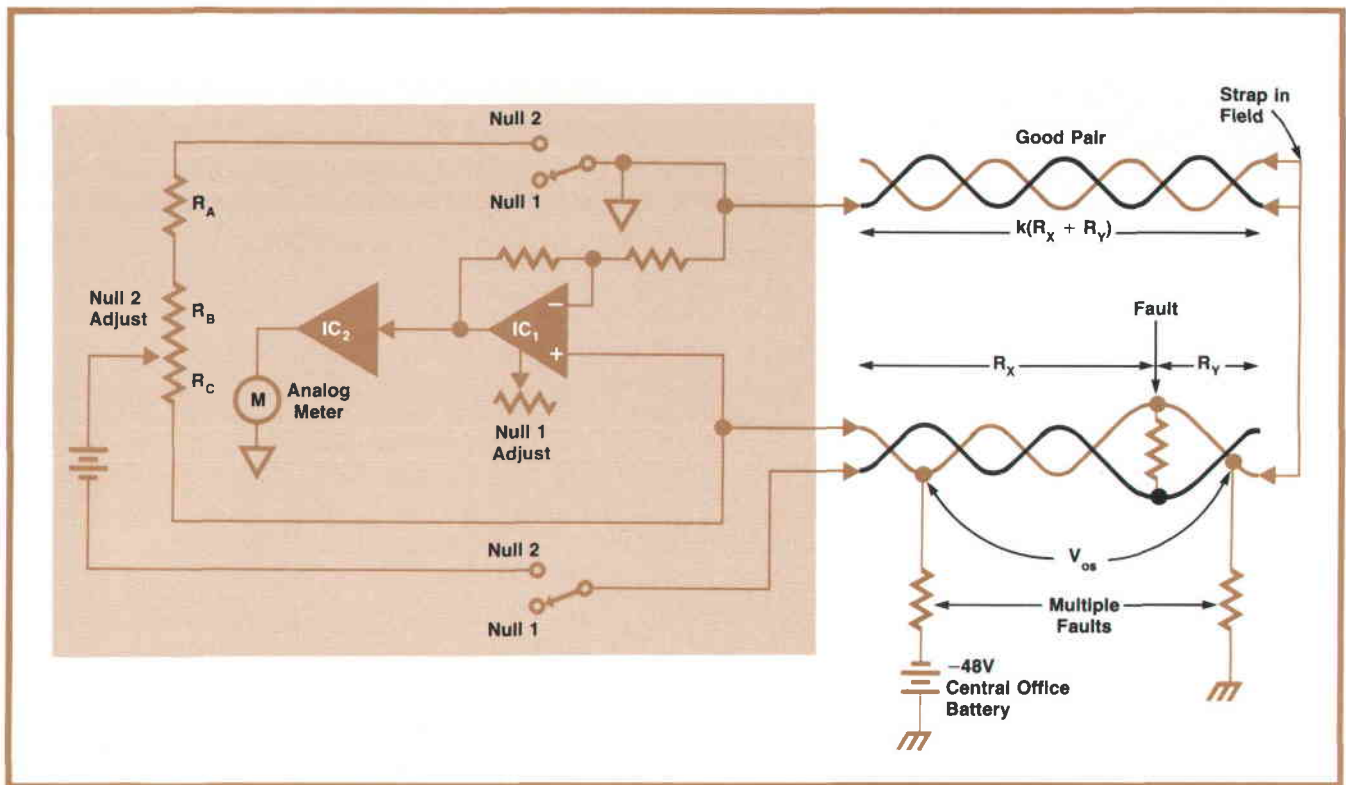

Fig. 5. Two nulls are adjusted in 4913A operation. Null 1 cancels voltages such as  $V_{os}$  that often caused errors in the old three-Varley method. Null 2 sets up a balanced-bridge condition.

Fig. 6 is a diagram of the circuit for determining fault distances for a short. Determination of strap to fault distance starts with the voltage  $V_1$  at the output of the buffer IC1.  $V_1$  is not affected by  $V_{os}$  because Null 1 has effectively eliminated  $V_{os}$ .

$$V_1 = I_o (k + 1) (R_X + R_Y) \quad (5)$$

$V_4$  results from voltage division across the Null 2 potentiometer.

$$V_4 = V_1 \frac{R_A + R_B}{R_A + R_B + R_C} \quad (6)$$

After substituting equations 4 and 5 into equation 6,

$$V_4 = I_o [R_Y + k (R_X + R_Y)] \quad (7)$$

The buffer IC3 uses one of the good wires as a sense lead to measure the voltage at the strap.

$$V_3 = I_o k (R_X + R_Y) \quad (8)$$

After subtracting,

$$\begin{aligned} V_5 &= V_4 - V_3 \\ &= I_o [R_Y + k (R_X + R_Y)] - I_o k (R_X + R_Y) \\ &= I_o R_Y \end{aligned} \quad (9)$$

At the input to the digital panel meter,

$$V_6 = A I_o R_Y \quad (10)$$

$A$  and  $I_o$  are calibrated to convert the resistance  $R_Y$  to the equivalent number of feet.

The other two distance readouts are obtained in a similar manner.

When only one wire of a pair is faulty an extra good pair is not required. The craftsman in the field shorts the two wires of the pair and the operation of the 4913A is unchanged. The internal system is configured differently and the mathematics describing the instrument operation are altered, but the basic idea is the same.

#### Acknowledgments

Mike Bergen helped work out the interface with telephone company equipment. Al Peterson contributed to the electrical design by solving our noise filtering problems. Tom Peterson had the mechanical design responsibility for the project. We also appreciate the total team effort that contributed to the development of the instrument. 📄

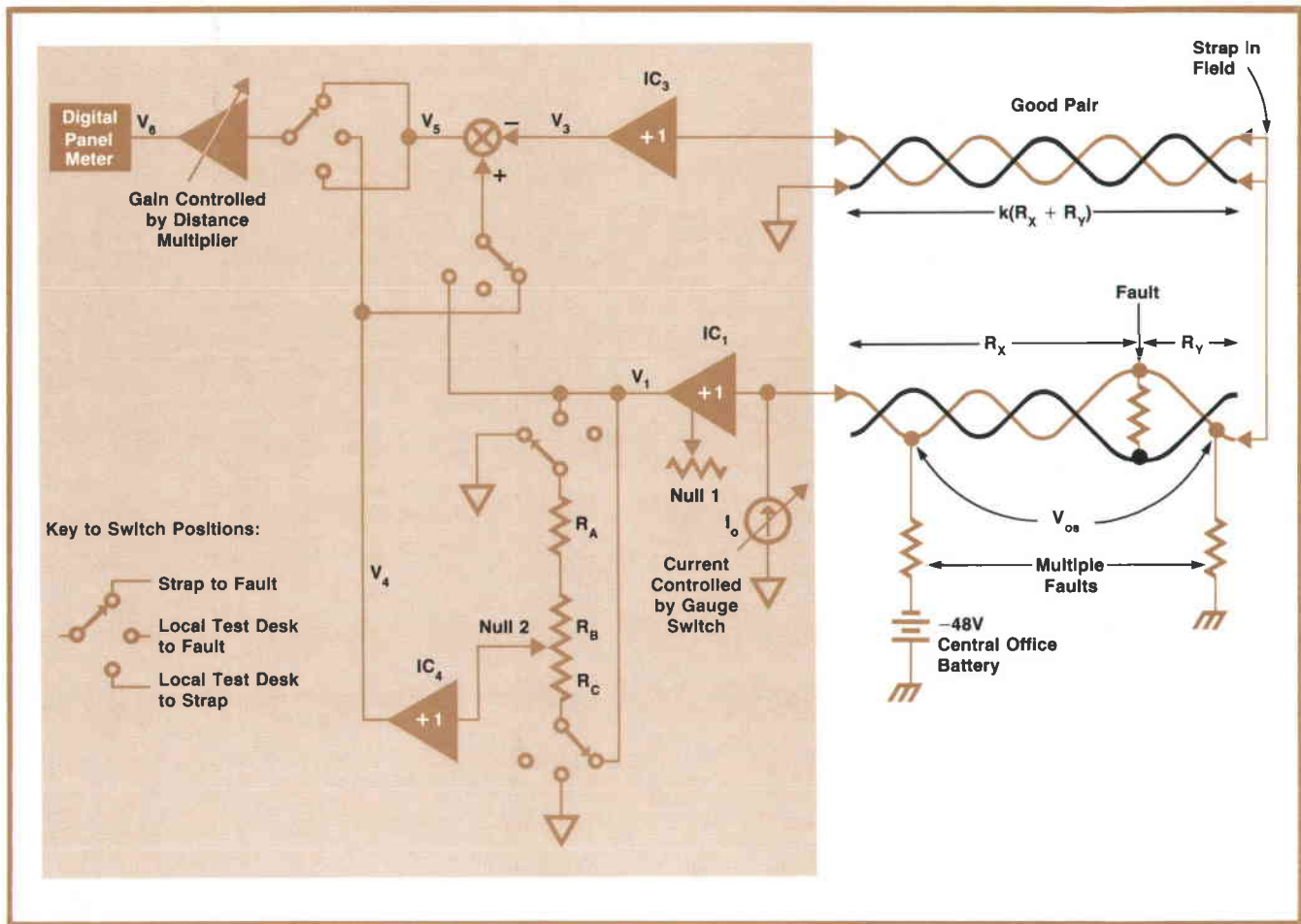

Fig. 6. After Null 2 is adjusted, selected distances are displayed automatically on the 3½-digit digital panel meter. No calculations are needed.

## SPECIFICATIONS

### HP Model 4913A Test Desk Fault Locator

#### Distance Measurement

##### OVERALL INSTRUMENT ACCURACY:

RANGE: X100, X10 ±1.2% ± 1 LSD  
X1 ±1.2% ± 5 LSD

DISTANCE RANGE: 0 to 199,900 feet.

DISTANCE DISPLAY: Displays distance from strap to fault, distance from desk to fault, and distance from desk to strap on digital display directly in feet.

GAUGE CALIBRATION: 19, 22, 24, and 26 AWG (copper); 17 and 20 AWG (Aluminum).

#### Fault Characteristics

**TYPES OF FAULTS:** Will locate shorts; crosses to working or non-working conductors; and grounds to earth, shield, or to working tips.

**RETURN LOOP REQUIREMENTS:** Grounds and crosses can be located using only CO battery or ground for return. Shorts require good pair for return (good pair need not be same gauge nor length as faulty pair).

**FAULT RESISTANCE:** Dependent on wire gauge and distance from fault. Under most conditions, faults as high as 10 MΩ can be located.

#### Foreign Voltage

**C.O. BATTERY:** dc loop voltages between good and bad wire caused by multiple faults can be nulled out. Measurement accuracy unaffected by C.O. battery crosses.

**INPUT PROTECTION:** Instrument circuitry protected against accidental application of foreign voltages as follows: ±100 Vdc or 280 Vp-p sinusoidal.

#### Self Check

Artificial line equivalent to 30,000 feet of 22 AWG wire with 300 kΩ fault at 18,000 feet. Built into test set for checking operation.

#### Power Requirements

Battery (or Equivalent)	Voltage	Type	Cells Req'd.	Typical Life*
Eveready 520 or	6V	Alkaline-MnO <sub>2</sub>	1	100 days
Eveready 731	6V	Zinc Carbon	1	50 days
Eveready 216	9V	Zinc Carbon	8	110 days
Burgess N60	90V	Zinc Carbon	1	600 days

\*Based on ½ hour per day intermittent on time.

**BATTERY TESTS:** Built-in test circuits permit instant check of battery conditions.

#### Test Cord

**DESCRIPTION:** Detachable test cord terminated in color coded 310 type plugs. Following test cords are available (one furnished with 4913A as specified):

**18080A TEST CORD:** For use with Western Electric 12-Type and 14-Type (cord-type) test desks. Has three plugs labeled "T1 R1", "T2 R2 FOR SHORTS ONLY", and "CO BATT (RING) CO GND (TIP)".

**18081A TEST CORD:** For use with Automatic Electric (cord-type) test desks. Has three plugs labeled: "T1 R1", "T2 R2 FOR SHORTS ONLY", and "CO BATT (RING) CO GND (TIP)".

**18082A TEST CORD:** For use with Western Electric 16-Type and modified 14-Type console (cordless-type) test desks. Has two plugs labeled: T1 R1" and "T2 R2 FOR SHORTS ONLY".

**PRICE IN U.S.A.:** \$1095.

**MANUFACTURING DIVISION:** DELCON DIVISION

690 East Middlefield Road  
Mountain View, California 94040 U.S.A.

## Appendix 4913A Sensitivity

To determine the sensitivity of the 4913A Test Desk Fault Locator, we first calculate the sensitivity of the null detector of a Wheatstone bridge to a small change in the impedance of one arm.

In the bridge circuit of Fig. A, all voltages are measured with respect to point B. Assuming an infinite input impedance for the null detector,

$$E_c = \frac{Z_2 E_A}{Z_1 + Z_2}$$

$$E_d = \frac{Z_3 E_A}{Z_3 + Z_4}$$

$$E_{det} = E_c - E_d = \frac{(Z_2 Z_4 - Z_3 Z_1) E_A}{(Z_1 + Z_2)(Z_3 + Z_4)} \quad (1)$$

In a balanced bridge,  $Z_2 Z_4 = Z_3 Z_1$  and  $E_{det} = 0$ .

We will now let  $Z_2$  change by a small amount  $\Delta Z_2$ . Differentiating equation 1 gives

$$\frac{\partial E_{det}}{\partial Z_2} = \frac{P E_A}{(P + 1)^2} \cdot \frac{1}{Z_2}$$

where  $P = Z_3/Z_4 = Z_2/Z_1$ . Thus

$$\Delta E_{det} = \frac{P E_A}{(P + 1)^2} \cdot \frac{\Delta Z_2}{Z_2} \quad (2)$$

In the 4913A, the minimum detectable  $\Delta E_{det}$  is 14  $\mu$ V. Suppose that the faulted line consists of 26,000 feet of 22 gauge wire and 9,000 feet of 19 gauge wire and the fault is 1,500 feet from the strap. What is the resolution of the 4913A in feet?

The actual 4913A circuit after Null 2 is shown in Fig. B.  $R_x$  represents the distance to the fault (33,500 feet) and  $R_y$  represents the distance from the fault to the strap (1,500 feet). In this case  $R_x = 480.0 \Omega$  and  $R_y = 12.1 \Omega$ .

The equation for the null condition is

$$(R_A + R_B) R_x = R_C (R_x + 2R_y)$$

In the 4913A,  $R_A = R_B + R_C = 5 \text{ k}\Omega$ . Therefore  $R_B = 122.9 \Omega$  and  $R_C = 4877 \Omega$ .

The voltage developed across the bridge depends upon the fault resistance  $R_f$ :

$$E_A = \frac{90 R_T}{18,000 + R_f + R_T}$$

where

$$R_T = \frac{(Z_1 + Z_2)(Z_3 + Z_4)}{Z_1 + Z_2 + Z_3 + Z_4}$$

In our example,

$$E_A = \frac{90 (2744)}{18,000 + 2744 + R_f} \quad (3)$$

Assuming a fault resistance of zero ohms and substituting the known values into equation 2 gives

$$\Delta Z_2 = 0.007 \Omega,$$

which means the 4913A resolution in this case is about one foot. For  $R_f = 10 \text{ M}\Omega$ ,  $\Delta Z_2 = 0.31 \Omega$  and the resolution is about 45 feet.

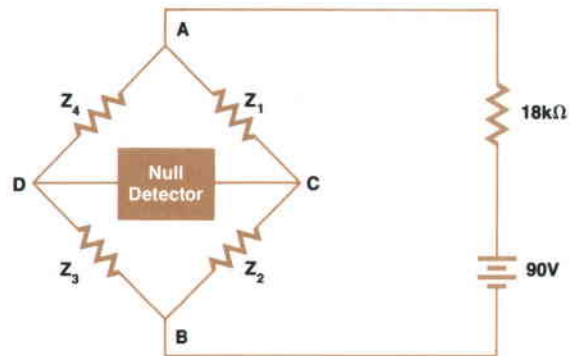

Fig. A

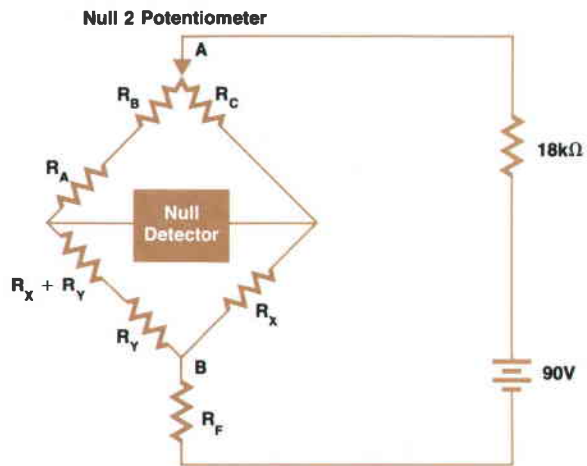

Fig. B



**Thomas R. Graham** (left)

Tom Graham received his BSEE degree in 1971 from the University of Minnesota, then did a year of graduate work as a teaching assistant at Massachusetts Institute of Technology before coming to HP in 1972. Initially a design engineer on the 4913A Fault Locator project, Tom now has

project responsibility for a new line of instruments. He's a member of IEEE. Among his outside interests are skiing, handball, and hiking, and he's also currently very much involved in the health food movement in all its aspects, from natural foods and vitamins to food allergies. A native of Minneapolis, Tom spent four years in the U.S. Air Force before going back to school for his degree.

**James M. Hood** (right)

Jim Hood is engineering group manager for outside plant instrumentation at HP's Delcon Division. At HP since 1967, Jim has contributed to the design of the 4920A Coaxial Fault Locator and had responsibility for development of the 4910 F/M Open Fault Locator and the 4912 F/M Conductor Fault Locator. A native of Jacksonville, Florida, Jim received his BSEE degree in 1967 from New Mexico State University and his MSEE degree in 1971 from Stanford University. He's a member of IEEE. Now living in San Jose, Jim is married and has a small son. He likes to play softball, basketball, and bridge, and he's an amateur photographer.

# High Efficiency Modular Power Supplies Using Switching Regulators

*The switching regulators' advantages of smaller size and cooler operation used to be counterbalanced by higher cost, slower transient response, and noise, both electrical and acoustical. These new power supplies reduce the disparity significantly.*

by B. William Dudley and Robert D. Peck

**R**EGULATING A DC POWER source has for years been done by dissipating power in a series pass regulator. This approach has size, weight, and thermal handicaps.

Switching regulators, on the other hand, dissipate little power and theoretically could be designed to dissipate no power at all. With practical circuits, they can achieve efficiencies as high as 80%.

A switching power supply converts the incoming ac line power to dc and uses the dc to generate a high-frequency pulse train that is transformer-coupled to a rectifier and filter. The resulting dc output voltage is levelled by controlling the duty cycle of the pulse train. The pulse-generating switching device is thus either fully on or fully off, and consequently dissipates little power.

Besides low power dissipation, another advantage of this technique is that the high pulse repetition

rates make possible the use of transformers, inductors and filter capacitors that are much smaller than those required for operation at power line frequencies. Power supplies that use switching regulators are thus smaller, lighter, and cooler running than their series-regulated counterparts.

This basic scheme is used in a new line of power supplies, the Hewlett-Packard 62,600J series (Fig. 1). These can supply the high current at low voltage needed by present-day digital computers, communication equipment, and process control equipment. At present there are nine models in this series, covering an output range extending from 40 amperes at 4 volts to 10.7 amperes at 28 volts. Although these units can supply up to 300W to a load, they weigh only 14.5 lbs (8.2 kg) and occupy less than  $\frac{1}{4}$  of a cubic foot (less than 8000 cm<sup>3</sup>), about one-third that of an equivalent series-regulated supply.

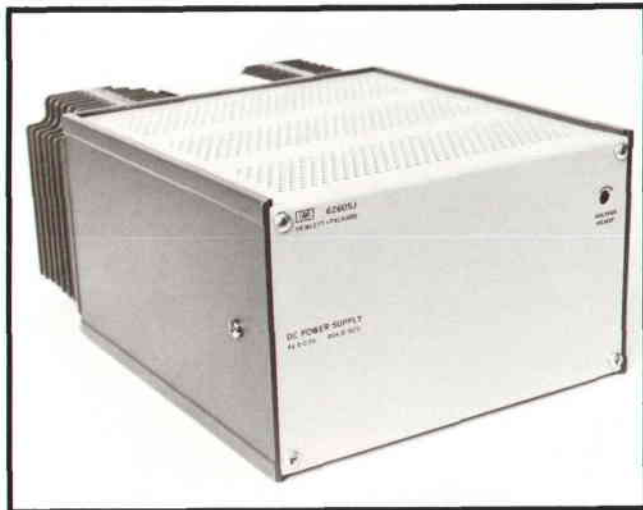
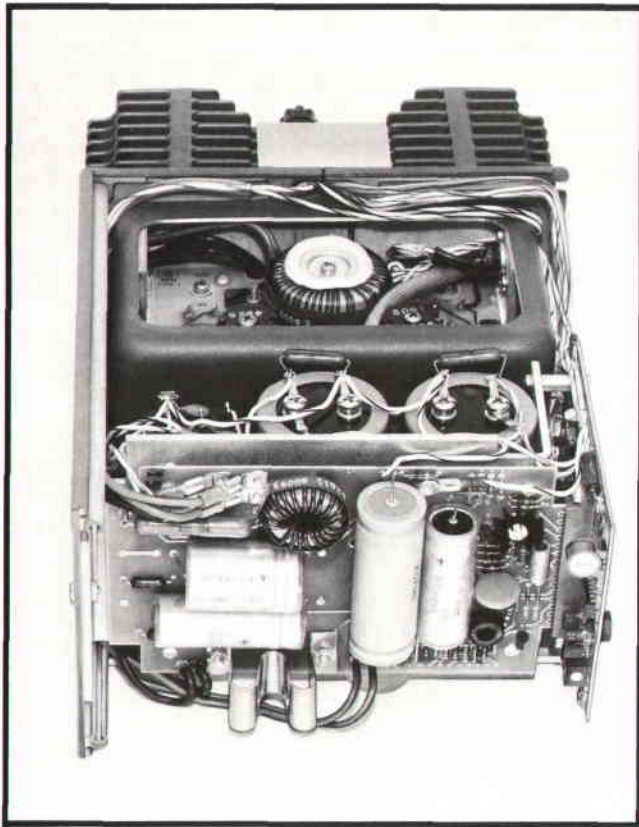

**Fig. 1.** New modular power supply for fixed-voltage applications uses a switching regulator to achieve 300 W output in a compact package.

## Historical Problems

Power supplies using switching techniques are certainly not new but they used to have certain problems. Switching speed was one. In the 1950's, supplies using transistors or SCRs as switches operated at pulse repetition rates around 2500 Hz. Although this was raised to 10 kHz by the 1960's, these frequencies are in the audio range so acoustic noise was a problem, requiring expensive damping and mounting of the magnetic components. Nevertheless, in airborne, space, and other applications where cost was a secondary consideration to weight and size, switching techniques were widely used.

Another problem was radio-frequency interference. The substantial voltage transients generated by switching the current on and off rapidly into an inductive load like the transformer created a spectrum of radio-frequency noise. Unless appropriate steps were taken, this would be conducted to the load,



**Fig. 2.** Aluminum shield, cut open in this view, houses power transformer, switching transistors, and other sources of electrical interference.

back into the ac line, and radiated into the surrounding environment.

Yet another problem was slow response to changes in line or load with consequent inability to smooth power line ripple. The use of conventional feedback techniques resulted in slow response because the two-stage LC filters commonly used were often included within the feedback loop.

### A New Age

Components have recently become available that now make switching techniques more practical while lowering costs. Transistors that are rated at 400 volts and that can switch up to 5 amperes in a switching time of less than  $1 \mu\text{s}$  are now available at reasonable prices. Concurrently, high-current, fast-recovery rectifiers, new ferrite materials that yield high-efficiency magnetic components, and new capacitors that have lower series inductance and resistance contribute to improved performance. It is therefore possible to design switching power supplies to operate with pulse repetition rates above the audio range, generally 20 kHz, eliminating the problem of acoustical noise.

In the new HP 62,600J series switching power supplies, major sources of radio-frequency interference

are enclosed in an aluminum shield attached to the heat sink (Fig. 2). This plus appropriate filtering reduces electrical noise by a factor of about 100. Noise conducted to the load within a range of 20 Hz to 20 MHz is less than 40 mV peak-to-peak.

The new switching regulator supplies also have improved regulation characteristics, holding the output within 0.1% of nominal, but able to respond to a change in load within 3ms. To gain an understanding of how this came about, an explanation begins with the elementary switching power supply shown in Fig. 3.

As shown by the waveforms, switch S is closed by the comparator and opened by the oscillator. Inductor L integrates the pulses generated by switch S. D1 is a "fly-back" diode that completes a current path for inductor L when switch S opens (the current through inductor L never decays to zero). The output voltage thus has a triangular waveform superimposed on the dc, rising while switch S is closed, and falling when S is open.

Whenever the dc plus the triangular wave drops below the reference voltage  $V_{\text{ref}}$ , the comparator switches on the driver. When there is an increase in load current, turn-on occurs sooner, thus widening the pulse. The width of the driver pulses is thereby modulated by the comparator to maintain a constant output voltage.

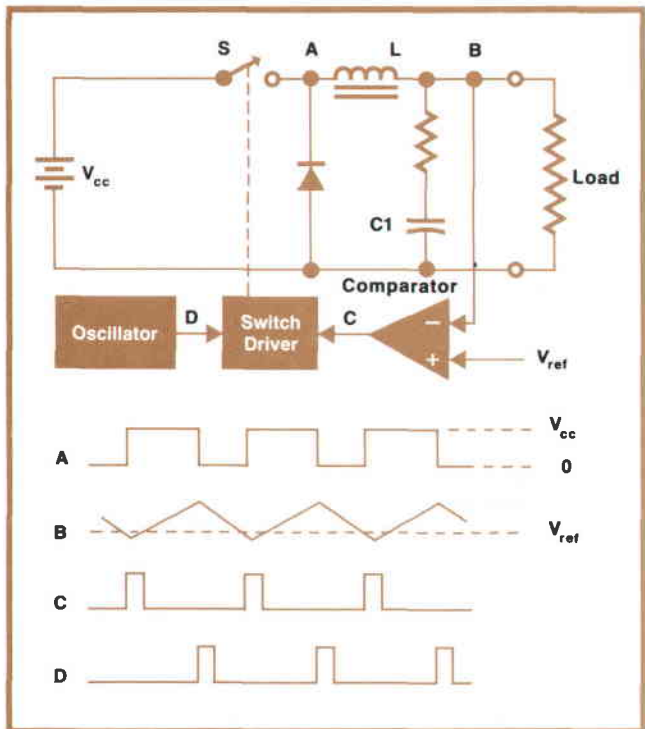

**Fig. 3.** Elemental switching regulator power supply maintains the output voltage constant despite load changes by adjusting the percentage of time that switch S is closed.

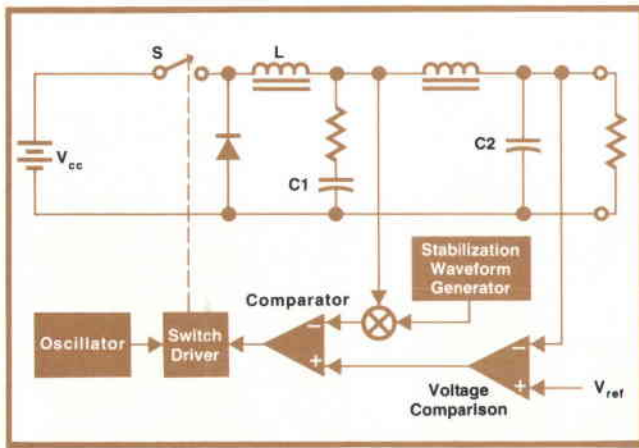

**Fig. 4.** By retaining the feedback loop around the first filter section, and adding a second loop around the second filter section, the new power supplies achieve relatively fast response with closely-regulated output.

This system responds to load or line changes within one cycle of the switching frequency and is thus able to smooth out line-related ripple.

It turns out that without additional compensation, this circuit tends to be unstable when the pulse duty cycle is less than 50%. This problem is resolved in the new 62,600J series power supplies by the addition of a parabolic waveform to the triangular feedback waveform. This increases the slope of the feedback waveform for light loads to give a more sharply defined comparison point.

Some high-frequency ripple is required for this system to operate. The ripple can be smoothed with a second LC filter but this raises a new problem: how to maintain good regulation when one of the filter sections is outside the feedback loop. The solution is diagrammed in Fig. 4.

In the circuit of Fig. 4, the reference voltage into the comparator is replaced by an error voltage derived from a comparison of the output, as measured at the output of the second filter, to the reference  $V_{ref}$ . The time constant of the comparison amplifier can be made long with respect to the oscillator period, enabling the supply to have as fine a regulation as desired. The sawtooth regulating loop around the first filter section, on the other hand, responds within one cycle ( $25\mu s$ ), smoothing out power line ripple and perturbations resulting from fast changes in the load. The overall response of the system to a load change from full load to half load or half load to full load, being limited by only one LC filter section, is  $\leq 3$  ms to within 0.1% of the nominal output voltage, a significant improvement over earlier designs.

### Reducing to Practice

The new 62,600J Power Supplies use these techniques but with additional refinements. A block dia-

gram is shown in Fig. 5 (all models in this series use the same basic circuit—only certain circuit constants differ).

The ac line connects directly to a rectifier bridge that functions as a conventional full-wave rectifier when there is no connection between points E and F, or as a voltage doubler when a shorting strap ties E and F together (two of the rectifiers are out of the circuit when the circuit functions as a doubler with the strap in place). This circuit, based on a principle used in the HP Model 2100 series Computers<sup>1</sup>, allows the supply to operate from either a 120 V or a 240 V line without requiring a line transformer.

The power line input also goes to the auxiliary power supply, a low power, series regulated supply that derives the voltages needed for operating the control circuit.

Saturation of transformer T1 is avoided by using two regulator switches (Q1 and Q2). These are switched on alternately so the current through the primary of T1 periodically reverses. This arrangement, in conjunction with the rectifier configuration, permits 400-volt transistors to be used with a 230V input, rather than the more expensive 800V transistors required by some other configurations.

The alternating current pulses in T1 are balanced by capacitor C3, which charges if there is any net dc resulting from any unbalance. The biases on transistors Q1 and Q2 are thereby shifted to correct the unbalance. Saturation of transformer T1 is thereby avoided.

The Q1-Q2 output pulses are stepped down to the desired voltage level by transformer T1 and rectified by diodes D2 and D3. These diodes can conduct up to 44 amperes but have a reverse recovery time of less than  $0.2\mu s$ . The rectified pulses are smoothed in the two-section LC filter to derive the output.

Regulator switching is controlled by the pulse width modulator, FF1, a flip-flop (Fig. 5). The D (data) input to this flip-flop is permanently connected high so when a clock input is received from the turn-on comparator, the Q output goes high, switching on Q1 or Q2. The next pulse from the 40-kHz oscillator applied to the "clear" input of FF1, resets the Q output to "low", terminating the pulse.

FF2 is another flip-flop connected as a binary divider. It switches states on each pulse from the 40-kHz oscillator thereby steering one drive pulse to Q1, the next to Q2, and so on to derive the alternating current input to transformer T1.

The 40-kHz oscillator is an asymmetrical multivibrator that spends  $5\mu s$  in one state and  $20\mu s$  in the other. The  $5\mu s$  output switches FF2 and clears FF1, forcing the FF1 Q output low to terminate the drive pulse. The  $5\mu s$  period establishes a "safety band"



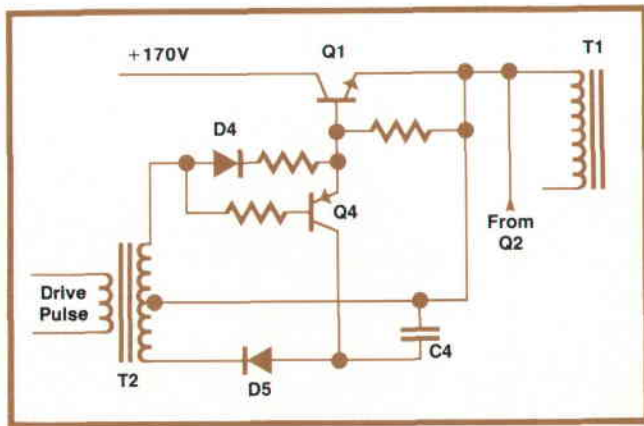

Fig. 6. The switching circuit speeds up turn-off of power transistor Q1.

former. The circuit is reset by removing the ac line power.

In the case of an ac line interruption, the "carryover" time (time during which the output remains within 2% of nominal), of interest for example in computer applications, is 30 ms.

When turn-on and turn-off sequencing of several power supplies may be required, the supply can also be held off by an external contact closure between the terminals marked "-" and "o" on the rear panel. This clamps the output of the voltage comparison amplifier so that no turn-on pulse can be initiated.

The supply and/or the load are also protected by an adjustable current limit. Current in excess of that desired develops an IR drop across the current-sampling resistor that causes the current-limit amplifier to pull down on the input to the turn-on comparator, preventing any increase in the drive pulse width. The range of the current limit control is from 50% to 113% of full-rated output.

### Series-Pass vs Switching Regulators

The circuits just described, using the new generation of components, make possible improved performance at lower cost. The reader might very well ask, then, are series-regulated supplies obsolete? Not really. Series-regulated supplies have quieter outputs, as little as 1mV peak-to-peak on the output, and faster response to load transients, typically less than 0.1ms. For output power levels below 100 W, they also have a lower dollar/watt cost, though this advantage is disappearing as the cost of the high-voltage fast-switching semiconductors needed by switching regulators continues to come down.

Switching regulated supplies are significantly smaller, lighter and cooler running, as shown by Fig. 7. With the introduction of the 62,600J series, switching supplies have a lower dollar/watt cost for output levels of 200-300 watts.

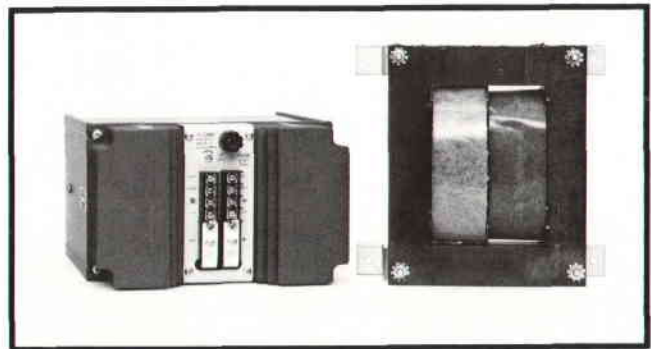

Fig. 7. A complete 300 W switching regulated supply is scarcely larger than just the power transformer of an equivalent series-regulated supply, and it weighs less —14.5 lbs (6.6 kg) vs the transformer's 18 lbs (8.2 kg).

### Efficiency

Efficiency is the principal advantage of the switching power supply. Consider the basic equation for efficiency,  $\eta$ :

$$\eta = \frac{P_o}{P_o + P_1}$$

where  $P_o$  is the output power and  $P_1$  is the power lost internally. Rewriting,

$$\frac{P_1}{P_o} = \frac{1-\eta}{\eta}$$

As an example, assume a 100W switching power supply with an efficiency of 80%. The power lost internally is:

$$P_1 = \left(\frac{1-\eta}{\eta}\right) P_o = 25 \text{ watts}$$

In comparison, a series-regulated supply with an efficiency of 40% would have an internal loss of 150 watts. In other words, doubling the efficiency cuts the internal dissipation by a factor of 6. This means that much less cooling is required by the switching power supply. This and the smaller size simplifies installation requirements.

### Acknowledgments

Thanks and appreciation are due Don Pauser for the mechanical design, Paul Amthauer for help in getting into production, Jim Gallo for product guidance, and especially Tim Buntin for breadboards and prototypes. 📧

### References:

1. R.D. Crawford and G. Justice, "A Bantam Power Supply for a Minicomputer," *Hewlett-Packard Journal*, October 1971.

## SPECIFICATIONS

### Models 62604J-62628J Switching Regulated Modular Power Supplies

#### RATINGS:

MODEL	DC OUTPUT		AC INPUT		POWER (Max.)	Efficiency
	NOMINAL VOLTAGE (Minimum Adj. Span)	CURRENT (AT 50°C)	CURRENT (Max.)			
62604J	4V (+0.5V)	40.0A	3.5A	308W	65%	Efficiency
62605J	5V (+0.5V)	40.0A	3.5A	308W		
62606J	6V (+0.5V)	33.0A	3.5A	308W		
62610J	10V (+0.5V)	25.0A	4.0A	334W	75%	Efficiency
62612J	12V (+0.6V)	23.0A	4.5A	334W		
62615J	15V (+0.75V)	20.0A	5.0A	375W	80%	Efficiency
62618J	18V (+0.90V)	16.7A	5.0A	375W		
62624J	24V (+1.20V)	12.5A	5.0A	375W		
62628J	28V (+1.40V)	10.7A	5.0A	375W		

**OUTPUT CONTROL:** Screwdriver control for output voltage adjustment is accessible through hole in front panel.

**DC OUTPUT ISOLATION:** Either output terminal may be grounded or floated at up to 100 volts off ground.

**CURRENT LIMIT:** Internal adjustment, factory-set to approximately 110% of maximum rated output current. Automatically resets when overload is removed. Minimum adjustment range is approximately 50% to 113%.

#### Performance

**LOAD EFFECT (Load Regulation):** Change in dc output voltage is less than 0.15% for a load change from 0 to 15% of rated output, and less than 0.10% for load change from 15% to 100% of rated output.

**SOURCE EFFECT (Line Regulation):** Change in dc output voltage resulting from change in ac input voltage over specified range, at any output voltage and current within rating, is less than 0.1%.

**RIPPLE (Ripple and Noise):** Residual ac voltage superimposed on dc output voltage, at any line voltage and under any load condition within rating is less than 20mV rms, 40mV p-p (20Hz to 20MHz).

**TEMPERATURE COEFFICIENT:** Change in dc output voltage per degree Centigrade change in ambient temperature under conditions of constant load resistance and ac line voltage following 30-minute warm up is less than 0.02%/°C over temperature range from 0 to 50°C.

**DRIFT (Stability):** Total drift in dc output voltage (dc to 20Hz) over 8-hour interval under conditions of constant line, load, and ambient temperature following 30-minute warm up is less than 0.1%.

**LOAD EFFECT TRANSIENT RECOVERY:** Time required for output voltage to recover within 0.1% of nominal following load change from 100% to 50% or 50% to 100% is less than 3ms.

**OVERSHOOT:** Turn-on transient is within regulation and ripple band. Turn-off is smooth exponential decay.

**CARRY-OVER TIME:** Time that output voltage remains within 2% of specified nominal under full load following removal of ac input power is greater than 30ms.

**OVERVOLTAGE PROTECTION:** Output voltage is continuously monitored and if it exceeds preset trip level, overvoltage protection circuit reacts within 30µs. Following activation, output voltage drops to less than 50mV.

**TRIP LEVEL:** Screwdriver adjustment accessible through hole in rear panel. Trip voltage range is from 1.5Vdc to 3.0Vdc above nominal rated output voltage.

**INPUT TRIP PULSE:** Pulse applied across OVP terminals on rear barrier strip remotely trips overvoltage circuit. Pulse requirements are:

Voltage: 8V min. to 15V max.

Width: 5µs min. to 2ms max.

**OVERVOLTAGE OUTPUT PULSE:** Pulse is generated across OVP terminals when overvoltage trips OVP circuit. Pulse specifications are:

Voltage: 2V min. to 12V max.

Width: 1µsec min. to 20µsec max.

Load Impedance: 10kΩ min.

#### General

##### INPUT POWER:

LINE: 104-127Vac, 48-440Hz, single phase. Operation at 190-233Vac or 208-254Vac is available as an option.

**OPERATING TEMPERATURE:** 0 to 50°C ambient. Output current for continuous operation is derated linearly from full output at 50°C to 50% of full output at 71°C.

**COOLING:** Convection cooled.

**THERMAL PROTECTION:** Internal thermostat opens ac line for an overtemperature condition. Automatically resets after power supply has cooled.

**REMOTE CONTROL:** Can be remotely programmed off and on with contact closure across "o" terminal and the "out" bus bar on rear panel barrier strip.

**REVERSE VOLTAGE PROTECTION:** Supply is protected against application of reverse polarity voltage across output terminals. Maximum steady-state reverse current can be up to 50% of rated output current.

**AC INPUT PROTECTION:** Line fuse in extractor post on rear.

**PRICE IN U.S.A. (all models):** \$395. 190-254 Vac input options: no charge.

**MANUFACTURING DIVISION:** NEW JERSEY DIVISION  
Green Pond Road  
Rockaway, New Jersey 07866



#### B. William Dudley

Bill Dudley came to HP after earning a BSEE degree from Rose-Hulman Institute of Technology in 1965. He designed the first models of the 6215 series low-cost lab power supplies then joined the marketing department as an applications engineer. A skier, sailor and licensed pilot, Bill spends most of his spare time as a volunteer fireman/paramedic. He and his wife Selena are both active in town affairs.



#### Robert D. Peck

After graduating from the Newark College of Engineering (1965), Bob Peck designed DVM's for a time then spent two years in the Army. He came to HP in 1969, going to work on switching regulators while working towards an MSEE at NCE. Married, and with two daughters, Bob also enjoys chess, hiking, and amateur theatricals.

Hewlett-Packard Company, 1501 Page Mill Road, Palo Alto, California 94304

Bulk Rate  
U.S. Postage  
Paid  
Hewlett-Packard  
Company

## HEWLETT-PACKARD JOURNAL

DECEMBER 1973 Volume 25 • Number 4

Technical Information from the Laboratories of  
Hewlett-Packard Company

Hewlett-Packard S.A., CH-1217 Meyrin 2  
Geneva, Switzerland  
Yokogawa-Hewlett-Packard Ltd., Shibuya-Ku,  
Tokyo 151 Japan

Editorial Director • Howard L. Roberts  
Managing Editor • Richard P. Dolan  
Contributing Editors • Ross H. Snyder,  
Laurence D. Shergalis

Art Director, Photographer • Arvid A. Danielson  
Art Assistant • Sue M. Reinheimer  
Administrative Services • Anne S. LoPresti  
European Production Manager • Kurt Hungerbühler

CHANGE OF ADDRESS: To change your address or delete your name from our mailing list please send us your old address label (it peels off). Send changes to Hewlett-Packard Journal, 1501 Page Mill Road, Palo Alto, California 94304 U.S.A. Allow 60 days.

# HP Archive

This vintage Hewlett-Packard document was  
preserved and distributed by

**[www.hparchive.com](http://www.hparchive.com)**

Please visit us on the web!

On-line curator: John Miles, KE5FX

[jmiles@pop.net](mailto:jmiles@pop.net)

