

JULY 1973

HEWLETT-PACKARD JOURNAL

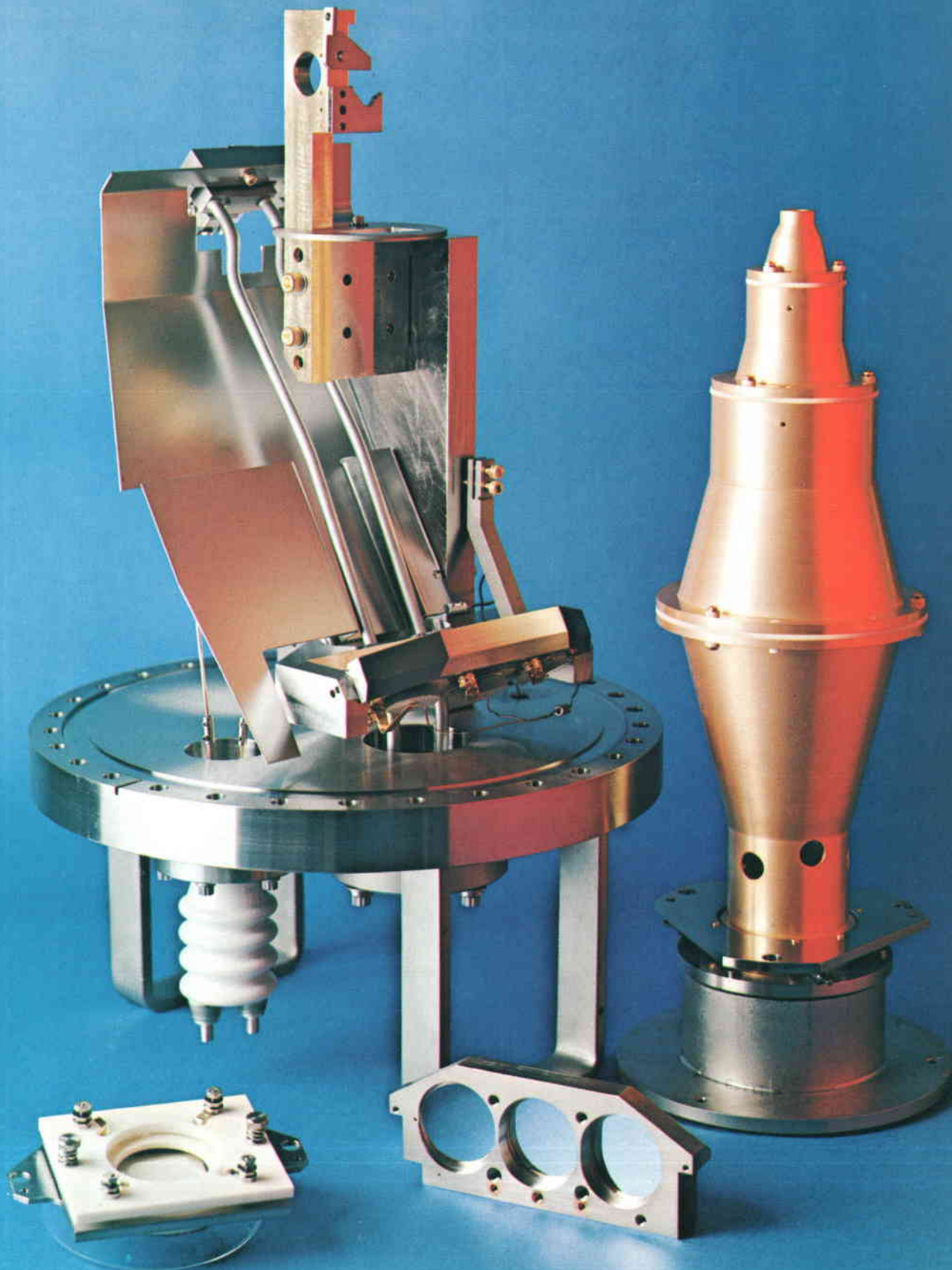

A Second-Generation ESCA Spectrometer

*Monochromatized x-rays, a dispersion compensated electron optical system, and an improved detection system enhance the sensitivity and resolution of a powerful analytical technique—
Electron Spectroscopy for Chemical Analysis.*

By Michael A. Kelly and Charles E. Tyler

ELECTRON SPECTROSCOPY for Chemical Analysis (ESCA) is a powerful analytical technique, able to study surface phenomena, to measure the energy levels of electrons in an element or compound directly and with great precision, and to give structural information about molecules as well as accurate quantitative information about sample composition (see box, page 5).

In late 1968, however, ESCA was being hampered by practical difficulties attributable mainly to the spectrum of the x-rays that are used to eject photoelectrons from the sample. The shifts in electronic energy levels that occur when chemical bonds are formed, thus indicating chemical structure, average about three electron volts and are at most only about 10 electron volts, while x-ray lines have inherent widths of about one electron volt. This means subtle chemical changes were often not resolved. Attempts to improve the apparent resolution by deconvoluting the photoelectron lineshapes were less than satisfactory, being complicated severely by the asymmetric $K_{\alpha_{1,2}}$ doublet of the x-rays.

X-ray satellite lines placed anomalous peaks in the spectra that would occasionally mask a minor but highly significant detail. Also, x-rays typically have a broad bremsstrahlung background, and this contributed a correspondingly broad and structureless photoelectron background in which small but significant detail could be lost.

There were other problems as well. The x-ray flux levels needed to obtain spectra in a reasonable time were so large that degradation of organic samples was common. The hard bremsstrahlung especially contributes to the degradation. Finally, insulating targets tended to become charged under the x-radiation, and charging produces ESCA peaks that are strongly shifted by the potential of the target surface and often severely broadened by surface potential gradients.

In 1968, when HP began development of Model 5950A ESCA Spectrometer, elimination of ESCA's problems was made a primary design objective. The obvious solution to the problems of broad line widths, satellite peaks and bremsstrahlung was to build an x-ray monochromator. But before this could be practical, it was necessary to develop a dispersion-compensated electron optical system and a new type of large-area detection system. Together all these elements make the 5950A a second-generation instrument capable of giving maximum resolution and maximum sensitivity simultaneously. Fig. 1 is a photograph of the new spectrometer.



Cover: *The monochromator assembly, crystal disperser, electron lens, and detector assembly from Model 5950A ESCA Spectrometer represent significant contributions of this instrument to the state of the art of Electron Spectroscopy for Chemical Analysis.*

In this Issue:

A Second-Generation ESCA Spectrometer, by Michael A. Kelly and Charles E. Tyler **page 2**

Compact Function Generator with Enhanced Capability/Cost Ratio, by E. Harry Heflin **page 15**

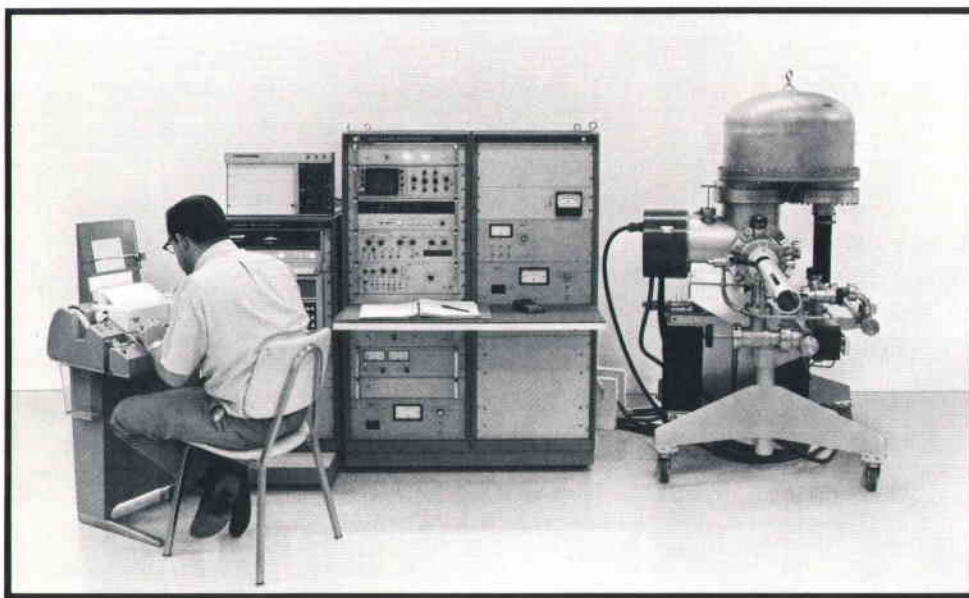

Fig. 1. Model 5950A ESCA Spectrometer operates at maximum sensitivity and resolution at all times. Background noise, satellite lines, and sample damage are sharply reduced, compared to conventional designs.

X-Ray Monochromator

The x-ray monochromator exploits Rowland's Theorem, which establishes that if a diffracting crystal with radius of curvature R is tangent to a circle of diameter R , and if an x-ray source and the sample are placed on this circle so that they both make angle θ relative to the crystal surface, then the radiation striking the crystal surface which satisfies the Bragg diffraction law will be reflected and brought to a focus on the sample, and all the other radiation in the x-ray spectrum will not be reflected. This is indicated in Fig. 2. The Bragg diffraction law is

$$n\lambda = 2d \sin\theta,$$

where n is any integer, λ is the x-ray wavelength, and d is the spacing of the atomic planes within the crystal.

There are actually three crystals in the monochromator. This is done to collect more x-ray intensity than would have been possible with a single crystal.

Fig. 3 shows two views of the monochromator. The plane of symmetry of the system, that is, the plane of Figs 2 and 3a, passes through the center of one spherically bent quartz crystal. Two similar crystals are symmetrically positioned on either side of this plane, as shown in Fig. 3b. Each crystal may be regarded as having a separate Rowland circle in a different plane from the others. These three planes intersect in the line passing through the anode and the sample.

The diameter of the Rowland circle is equal to the radius of curvature of the atomic planes of the bent crystal. This geometry introduces aberrations which limit the diameter of the reflecting crystal.

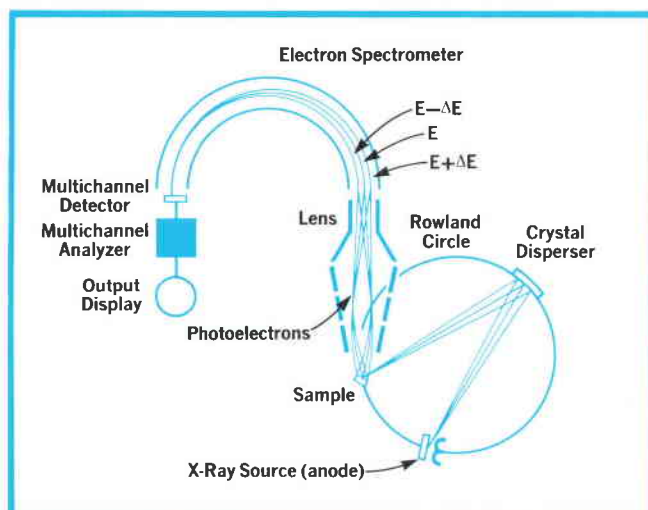

Fig. 2. Schematic drawing of Model 5950A ESCA Spectrometer showing x-ray and electron paths through monochromator and dispersion-compensated electron optics.

However, the reflection of the $AlK\alpha$ radiation from the crystal planes takes place at a Bragg angle θ of 78.5° . A Bragg angle close to 90° has the advantages of minimizing the geometrical aberrations and maximizing the Bragg diffraction intensity and the dispersion of the monochromator. Also, the bending of each crystal wafer causes it to have a nonuniform strain distribution and hence a variation in lattice spacing throughout the wafer. This variation of lattice spacing in the thin surface layer ($3 \mu\text{m}$) which the x-rays penetrate gives rise to a significant aberration, but this aberration has the opposite sign from that of the geometrical aberration resulting from the lack of conformation of the crystal surface to the Rowland circle, so they partially cancel. By proper choice of wafer thickness



Fig. 3. X-ray monochromator has three spherically-bent crystals with three Rowland circles that intersect at the anode and sample.

and other parameters, a considerable degree of cancellation has been attained.

The x-ray monochromator removes outright the bremsstrahlung and the satellites. The anode is made large enough that the Bragg condition is satisfied for the entire $AlK_{\alpha_{1,2}}$ doublet, and this spectrum is spatially dispersed across the sample. This is done to get as much flux on the target as possible, since the basic x-ray flux limitation is the power density at the anode.

Nevertheless, due to the small crystal size necessary to control spherical aberrations, only about 3 milliradian of solid angle is intercepted by the crystals and the K_{α} x-ray flux is reduced by two orders of magnitude over a typical achromatic spectrometer. This, plus the absence of bremsstrahlung, means that sample damage is very sharply reduced.

Dispersion Compensation

The energy of the x-ray photons incident on the sample varies across the sample by about one electron volt, which is the width of the x-ray line. As a result, the kinetic energy of the photoelectrons from a given energy level also varies by one electron volt.

The electron lens and electron spectrometer work together to cancel out this inherent variation. This can be seen by referring to Fig. 2. The electron lens (Fig. 4) has four elements or three gaps, corresponding to three degrees of freedom in the electron optics. The first is used to retard the photoelectrons of interest to 115 eV kinetic energy before they enter the electron spectrometer. The second is used to form a focused electron image of the target at the spectrometer entrance. The last degree of freedom is used to magnify the image ($-5.0\times$) so the dispersion of the electron spectrometer at 115 eV kinetic energy precisely cancels the dispersion of the x-ray monochromator across the sample.

This cancellation, called dispersion compensation, thus removes the inherent line-width limitation on instrument resolution. 1486 eV photons have adequate penetration in quartz (i.e., bring into play enough crystalline planes) to have a resolution of 0.165 eV, and the dispersion compensation scheme is capable of realizing this resolution. In fact, resolution has been given away up to 0.220 eV in spherical aberrations to achieve higher flux from larger crystals.

Cancellation of the effect of the inherent x-ray line width also removes the effect of the x-ray line shape. The remaining dispersive effects combine in an uncorrelated, structureless fashion, so the response of the instrument to a perfectly sharp electronic state is now Gaussian. This makes deconvolution work very much easier, since the Fourier transform of a Gaussian function is also Gaussian.

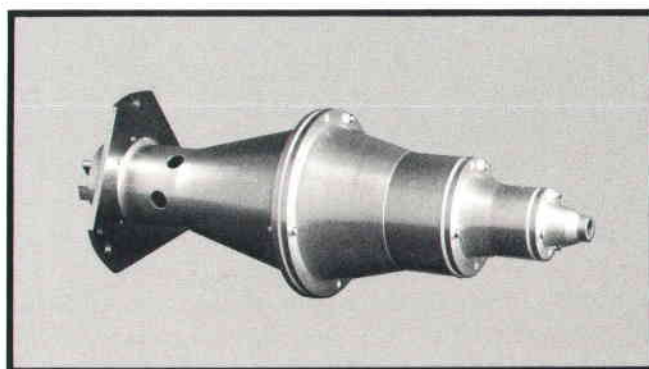

Fig. 4. Electron lens has four elements and three gaps. Thus there are three degrees of freedom in the electron optics.

Electron Spectroscopy for Chemical Analysis

Almost three-quarters of a century ago, Einstein explained how electrons are knocked out of solids by sufficiently short electromagnetic radiation. Yet until recently practical applications of this fundamental phenomenon have been limited almost entirely to radiation detectors, photomultipliers, and photovoltaic and photoconductive cells. That the escaping electrons contain important information about the material from which they are ejected has been a recent discovery, dating back scarcely a decade.

Einstein's theory of the photoelectric effect predicted that the ejected electron's energy should equal the energy of a quantum of the incoming electromagnetic radiation less the electron's binding energy. However, early measurements of the energies of escaping electrons were disappointing. There was little correlation between Einstein's simple relation and the energies observed. This lack of correlation wasn't too surprising, since electrons typically make numerous collisions with atoms before escaping, and hence lose some of their original energy.

It wasn't until the early 1960's that it was demonstrated that collisions don't always obliterate the information contained in the electron energies. Dr. Kai Siegbahn, head of the Institute of Physics of the University of Uppsala, Sweden, constructed a high-resolution electron energy analyzer and observed the electrons ejected from a target by the action of x-rays. He found that while many electrons did suffer collisions before leaving the target, a substantial fraction did not, and for these electrons Einstein's simple relation held. Thus, by illuminating a sample with nearly monoenergetic x-rays and measuring the energies of the electrons emitted, one could determine the binding energies of the electrons in the sample. Since these binding energies are quantized, and every element or compound has a unique set of binding energies, this information is sufficient to determine what elements are present in the sample, and often the chemical compound to which a given element belongs.

Siegbahn and his colleagues pursued this technique, calling it ESCA (Electron Spectroscopy for Chemical Analysis), and have published numerous papers and two excellent books describing their researches.

HP became interested in the technique in 1968 at the instigation of a member of the board of directors, Luis Alvarez, and Don Hammond, the director of the HP Physical Electronics Laboratory. They saw that the technique had great potential, both as a general-purpose research tool and as an analytical instrument to solve applied problems. A development project was initiated in the Physical Electronics Laboratory with Professor Siegbahn as a consultant, and the result was the Model 5950A ESCA Spectrometer.

How ESCA Works

In an ESCA spectrometer, x-rays from a specific anode material illuminate the sample, causing electrons to be ejected. Many of these electrons will have come from the first few atomic layers of the sample, and will not have suffered any collisions with atoms. The kinetic energies of these photoelectrons are measured to high precision and the number of electrons detected is plotted as a function of their energy. The resulting energy spectrum has sharp peaks that correspond to the electronic energy states of the sample material.

Typical ESCA spectrometers use x-rays from the $\text{AlK}\alpha_{1,2}$ line at 1486 electron volts or the $\text{MgK}\alpha_{1,2}$ line at 1253 electron volts. With the energy of the x-rays known, the binding energy E_b of a given electron can be determined from the relation

$$E_b = h\nu - E_k - e\phi$$

where $h\nu$ is the x-ray photon energy (h is Planck's constant and ν is the x-ray frequency), E_k is the measured kinetic energy of the photoelectron, e is the electronic charge, and ϕ is the work function of the spectrometer. This is illustrated in drawing A (with the spectrometer work function omitted for clarity).

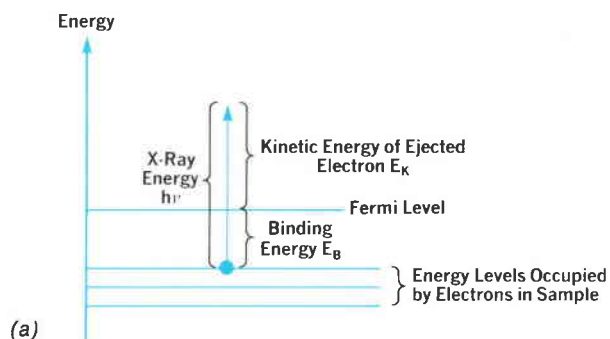

In the HP 5950A ESCA Spectrometer, electron energy is analyzed by passing the electrons between two hemispherical domes that have a potential difference between them. Electrons of the desired energy follow a circular orbit between the domes and reach the detector, while electrons having higher or lower energies strike one of the domes and are not detected. The number of electrons striking the detector for a given potential difference is counted and plotted as a function of energy.

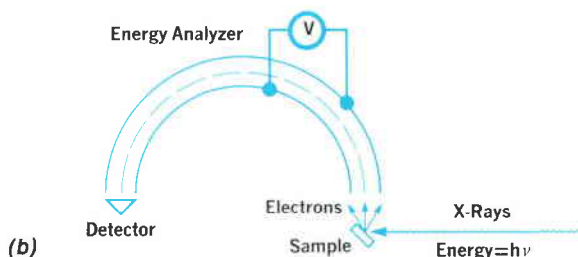

Advantages of ESCA

ESCA is a universal technique. No nuclear magnetic moment, electric dipole, or other quantum-mechanical "handle" is required; all matter has electrons. The locations of the several peaks in an ESCA spectrum provide an immediate elemental analysis of the target, since the binding energies of the shells within each element have been measured and tabulated. Furthermore, ESCA (as applied to solids) is a surface technique, with the photoelectrons comprising the sharp peaks all coming nominally from the top 50 angstroms of the target. That is, ESCA looks at that part of the solid that interacts with its environment. This can have

considerable practical significance. For example, two catalysts with the same bulk properties can have sharply different catalytic behavior.

However, the advantage of ESCA is much more than this. When a bond is formed between two atoms, the outer electronic shells coalesce into molecular shells, called molecular orbitals, at different binding energies. These changes in binding energy, called chemical shifts, carry uniformly into the innermost shells of the atom as well, so the potentials of the shells within an atom are shifted by the same amount (to first order) when a bond is formed. This is why the chemical shifts have been so difficult to observe in the past. That is, while previous spectroscopies have dealt with transitions between equally shifted shells, ESCA deals directly with individual atomic and molecular shells, so the

chemical shift is a first order effect in ESCA.

The chemical shift associated with a bond between two atoms can be calculated from quantum mechanics, and the calculation can be checked on a simple, well understood compound of those atoms with the ESCA spectrometer. Then, by measuring the chemical shifts experienced by the several atoms of a complex molecule, one can determine which atoms are bound to one another within the molecule. That is, ESCA provides structural as well as stoichiometric information.

In summary, the molecular orbital is a familiar and fundamental concept of chemistry, but its study and exploitation is incomplete. ESCA seems perfectly suited to further illuminate its nature.

Large-Area Detection System

The x-ray monochromator and dispersion compensation provide higher resolution, the absence of bremsstrahlung and satellites, and sharply reduced sample damage. They also make lineshapes significant and render deconvolution work much easier. However, the price is a hundred-fold reduction in $K\alpha$ flux and a corresponding hundred-fold drop in signal level. This factor is recovered in the large area detection system.

The conventional exit slit at the output of the electron spectrometer is replaced with a 1.1-inch-square imaging electron multiplier. Wherever a single photoelectron strikes the input of this active surface, a corresponding pulse of 10^8 electrons exits from the same position on the output surface and strikes a phosphor plate. The resulting flash of light is imaged onto and stored within the target of a vidicon television tube. The event remains stored until erased by the conventional TV raster scan of the vidicon electron beam, which converts the event to an electrical pulse at the vidicon output. These pulses are transferred to an HP 5401B Multichannel Analyzer, where they are entered into the proper place in the spectrum. See Fig. 5.

With this detection system, all electrons arriving at the detector at any energy level and at any time are detected. The multichannel analyzer monitors the scan voltage of the vidicon tube and derives the information necessary to sort the pulses it receives according to the energies of the detected photoelectrons. Each pulse is assigned to one of up to 1024 multichannel-analyzer channels, each of which corresponds to a particular energy.

Counts are accumulated in the various channels for an appropriate time and the resulting spectrum, a plot of counts per channel versus channel energy level, can be displayed visually, drawn by an X-Y plotter, or put into a computer for analysis or further processing.

An unusual feature of this system is the absence of slits. In most spectrometers, there is a slit that is opened for survey runs and then narrowed when high resolution is desired, so much longer runs are required. In the new spectrometer, each line of the TV raster corresponds to a narrow slit positioned to intercept electrons of a particular energy. Thus the TV system is equivalent to 262 fully active, conventional exit slits, so the hundred-fold drop in signal level left after monochromatization and dispersion compensation is regained. This provides a signal rate that compares favorably with conventional instruments. Thus the 5950A runs at maxi-

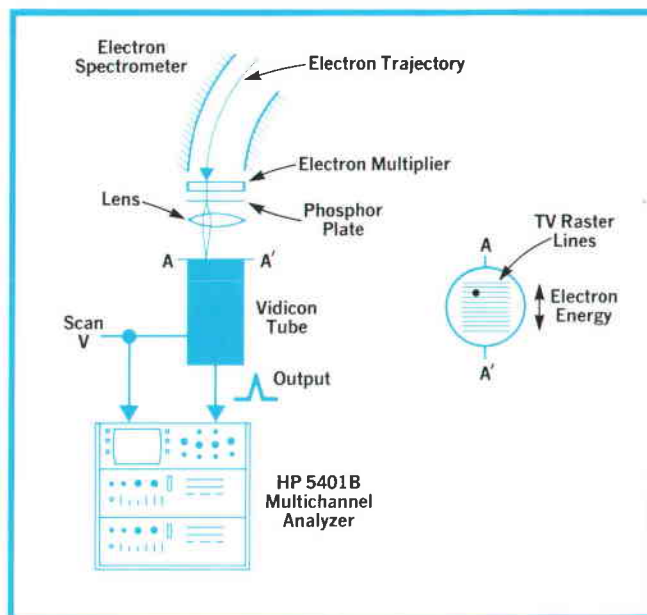

Fig. 5. In the wide-area detection system, an incoming electron strikes a multichannel electron multiplier, resulting in a flash of light from a phosphor plate. The flash is imaged onto a vidicon tube. As the vidicon scans, each flash produces a pulse that is counted by the Multichannel Analyzer and classified according to the energy of the incoming electron. The result is the ESCA spectrum, a plot of number of photoelectrons versus energy.

imum resolution and maximum throughput at all times.

Applications of ESCA

Although still in its infancy, ESCA has found a broad range of applications, from basic studies of the structure of solids to solving problems in manufacturing processes. The technique has been applied successfully to the effect of sunlight on polymers, the composition and uniformity of deposited thin films, the efficiency of washing processes, the molecular structure of complex organic molecules, the activity of catalysts, and the effect of lubricants on metallic surfaces, as well as many other problems.

Perhaps the best way to describe the utility of the technique, and in particular, to show how some of the instrumental features of the HP 5950A increase its power, is to consider a few examples.

A Basic Study in Solid-State Physics

The last decade has seen a vast increase in the sophistication of solid state devices: light-emitting diodes, high-frequency high-power transistors, optical detectors, metal-oxide-semiconductor devices, and large-scale integrated circuits, to name a few. These developments are possible because of a detailed understanding of the bulk and surface properties of semiconducting materials, whether these are doped silicon or more complicated alloy systems.

One interesting alloy presently receiving considerable attention is the germanium-tellurium system. To understand the electrical or optical properties of such a compound, a detailed knowledge of its band structure is necessary. ESCA provides a powerful and direct means for determining this, as illustrated by the spectra in Fig. 6 of a 50% germanium, 50% tellurium alloy.

The first spectrum was taken after the sample was ion bombarded to remove any surface contaminants, and hence indicates its bulk composition. Each peak in the spectrum corresponds to a specific electronic state within the material, and by observing its energy and structure, it can be assigned to a specific atom. Of particular interest is the valence band structure, the spectra of the loosely bound electrons within the material, which are responsible for its chemical and electrical properties. In this region, the Te (5s) and Ge (4s) levels are clearly seen, and the Te (5p) and Ge (4p) levels merge to form the highest energy (i.e., least tightly bound) electrons in the sample. Thus, by looking at this one spectrum, one has a detailed picture of how all the electrons in the material are configured.

The second spectrum shows the same sample after exposure to air, and thus reflects the normal surface properties of the alloy, rather than its bulk characteristics. One sees immediately that the surface has been oxidized, since there is a large oxygen line at about 24 eV binding energy. In addition, the spectrum of the loosely bound valence electrons has changed substantially. The strong peak due to Te (5p) and Ge (4p) is no longer evident, and there is an additional level at about 5 eV binding energy, due to the oxygen.

These spectra contain other information as well. For example, it is possible to say that all of the oxygen on the surface is bound to germanium atoms. The evidence for this is that the Ge (3d) level has shifted about 2 eV higher in binding energy (to 32.7 eV), indicating that the electron density surrounding it has decreased, as it would if it were bound to oxygen. The Te (4d) doublet, on the other hand, is unchanged. The physical changes that are responsible for the differences between these two spectra are quite subtle; they involve only a small fraction of the electrons surrounding each atom, and they occur only in a very thin layer of the sample near the surface.

One reason these changes are so evident is that the HP spectrometer has a very low background, that is, the spectra drop off sharply at the Fermi level (0 eV binding energy) with few stray or background counts above it. Hence small peaks are easily seen. This is a result of using monochromatized radiation on the sample, which removes the bremsstrahlung and confusing satellite radiation from conventional x-ray sources. In addition, the high resolution of the spectrometer preserves the detailed structure of the peaks, which is particularly important in the valence region.

To interpret these spectra adequately, though, one needs to look at more than the valence band. Many elements have loosely bound electrons, so one should be sure what is present on the surface that contributes to the valence band spectra. The wide scan capability of the HP 5950A provides this information by simultaneously giving the spectra of more tightly bound electrons. Thus one has information about all the elements present on the surface of the sample, so one can tell whether minute contaminants have affected the valence spectra. By looking at the inner "core" electrons as well as the valence bands, one obtains a complete and consistent characterization of the material.

An Industrial Application

A manufacturer of optical equipment recently had yield problems in fabricating a device that re-

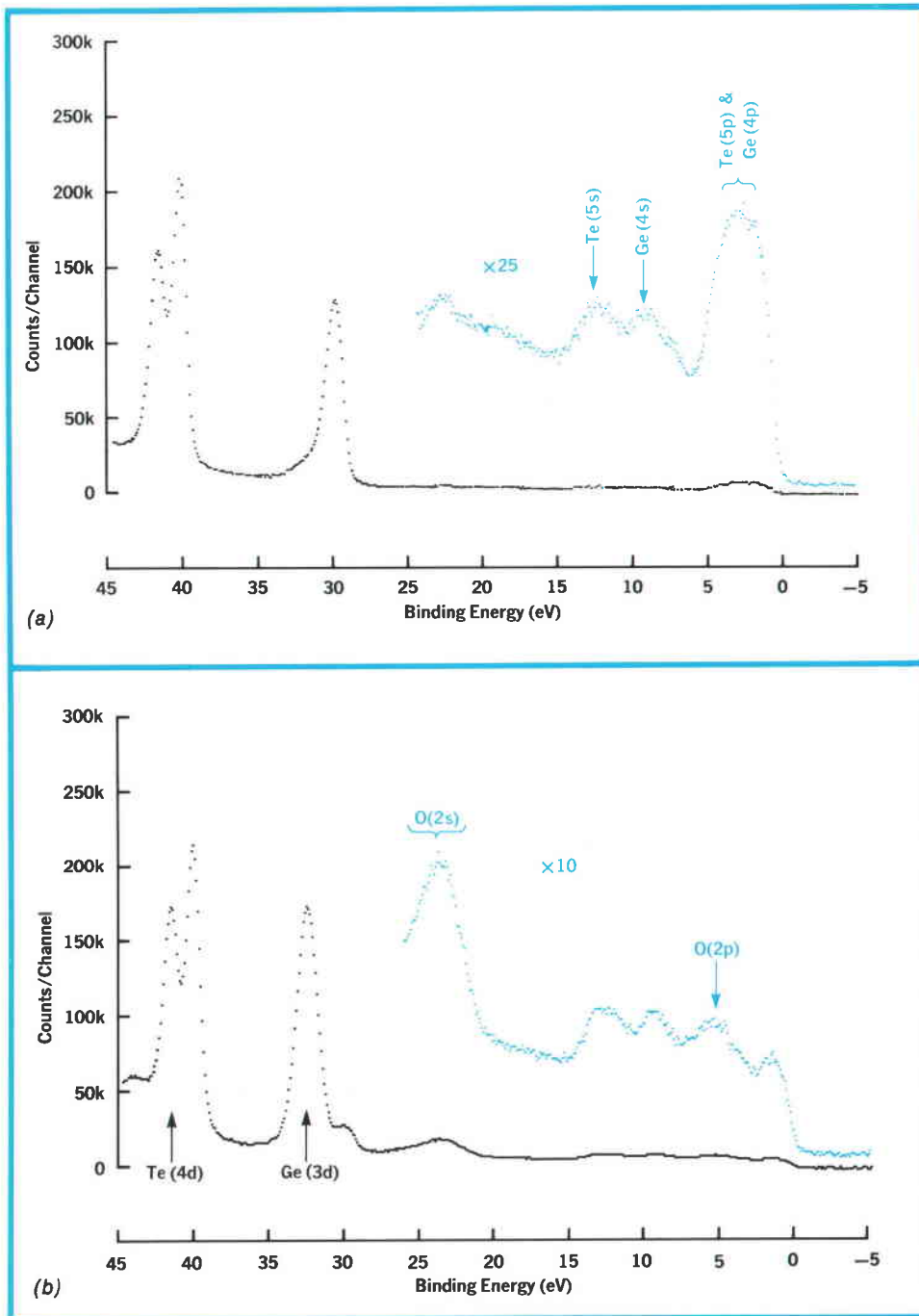

Fig. 6. ESCA spectra of an alloy of 50% germanium and 50% tellurium (a) after ion bombardment to remove surface contamination and (b) after exposure to air. Together these two spectra provide a complete and consistent characterization of the material.

quired a very low leakage dielectric layer. The charge on some devices, after assembly inside a glass envelope, would leak off at too high a rate. The devices were pre-tested before assembly and appeared to be good.

This puzzling situation, typical of a wide variety of fabrication problems, was studied with ESCA. Fig. 7 shows two spectra, one of a good device, the other of a bad one. In both, the constituents of the dielectric coating are clearly visible. In the bad one, however, a number of differences are apparent. There is nickel present, presumably from the elec-

trodes of the device, and some sulfur and lead. The presence of lead was the clue that appeared most likely to provide a solution to the problem. During assembly, portions of the glass envelope were heated. Some of the glass contained lead, which vaporized and condensed on the device. The manufacturing process is now being modified to eliminate this problem.

The detection and interpretation of very weak signals, such as the lead peaks in Fig. 7, can present some difficult problems. By eliminating satellite peaks and excessive background, HP's monochro-

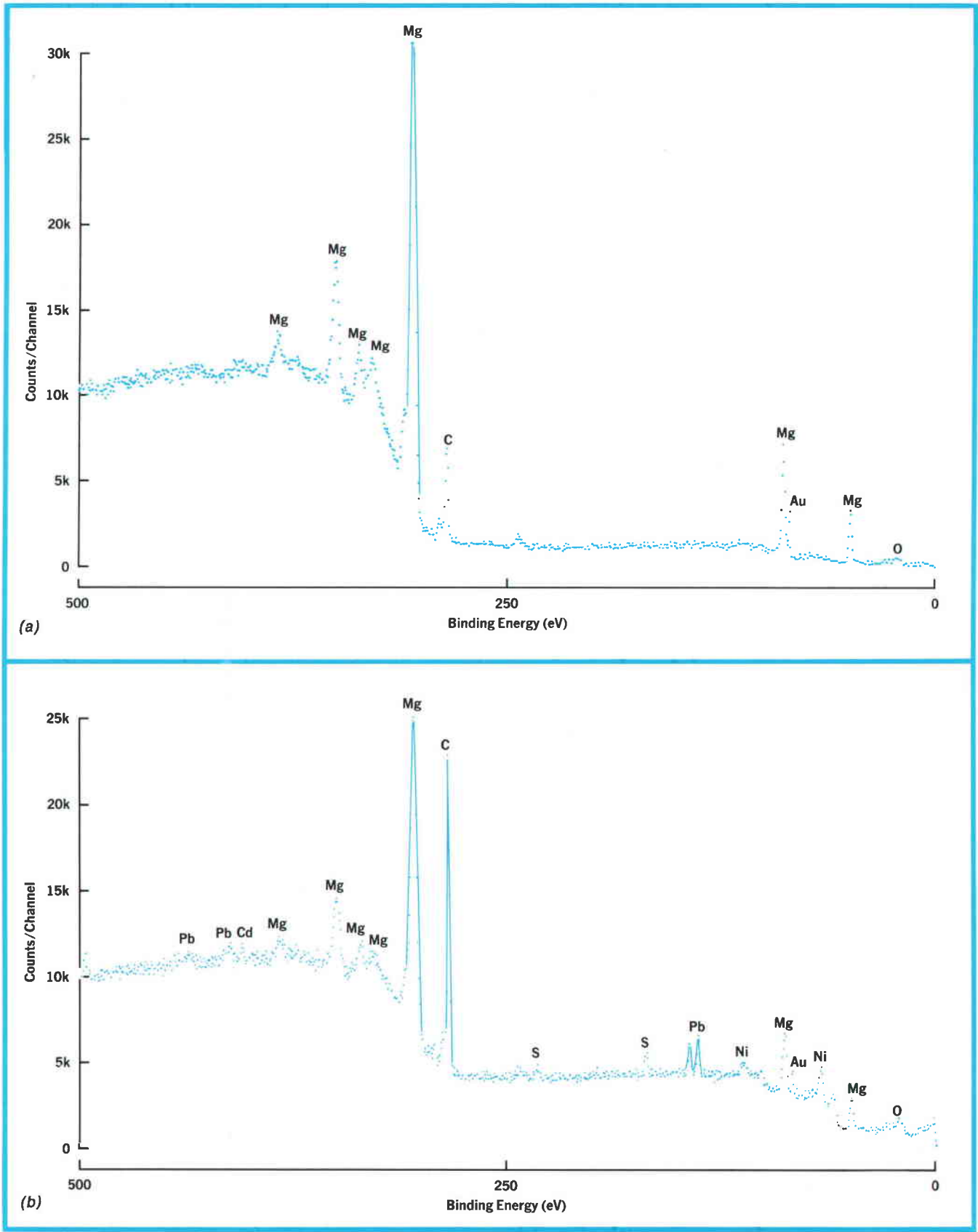

Fig. 7. ESCA helps a manufacturer find a reason for low yields. Lead peaks in the ESCA spectrum of a leaky dielectric layer (b) were traced to contamination during heating of a leaded-glass envelope. Spectrum of a good device (a) has no lead peaks.

matized x-ray source alleviates these problems, and in addition, provides higher resolution, so assigning small peaks to specific elements is greatly simplified.

A New Tool for Catalysis

Catalysts are essential to the manufacture of materials that have influenced our society greatly, from plastics to gasoline. Yet determining the properties of these compounds and finding methods to evaluate their efficiency are important problems that until recently have defied almost all analytical techniques. Predicting the performance of fresh catalysts has been equally difficult. ESCA offers hope here; not only can it determine the oxidation states of species at the surface, but it can give information about surface conductivity, an important parameter for characterizing catalyst activity according to studies on a few catalyst systems.

An example of the type of information ESCA can provide about a catalyst can be seen in the following

The Charging Effect

Early measurements on insulators using ESCA yielded confusing results. Peaks corresponding to different elements did not have the energy predicted by Einstein's simple relation, but appeared to be shifted to higher binding energies by amounts that depended on the material involved and also, somewhat unexpectedly, on the type of instrument used. These shifts appeared larger on the HP 5950A Spectrometer than on any other commercial instrument presently available, sometimes by as much as an order of magnitude.

The reason for the shifts is simple. The x-rays incident on the sample cause electrons to be emitted, so the sample surface acquires a net positive charge. In all spectrometers there are some stray electrons present in the vicinity of the sample to prevent the charging from continuing indefinitely, and the sample ultimately comes to equilibrium at a potential sufficient to attract enough stray electrons to compensate for those emitted. In the HP instrument this charging effect is enhanced since few stray electrons are produced. This is because focused, monochromatized x-rays illuminate the sample.

Until recently, this charging effect was regarded as a nuisance. In the 5950A, however, means are provided so that one can turn the charging on or off as desired. This capability yields a surprising amount of additional information about the sample.

Good examples of charging shifts can be seen in the oxygen and boron lines in Fig. 8, page 11. The text accompanying that illustration explains the shifts' significance.

The charging effect is turned off by supplying a flood of electrons having a uniform low energy to the sample. The surface potential can thus be clamped to a potential determined by the energy of these electrons.

The flood gun that supplies the low-energy electrons is an optional accessory to the Model 5950A ESCA Spectrometer.

example. The compound involved, VB_2 , is used in the dimerization of carboxylic acids and is not a catalyst in the strict sense, but the features of its spectrum are representative of a number of catalyst systems, although simpler.

Fig. 8 shows a broad spectrum of VB_2 taken with the HP 5950A ESCA spectrometer. Peaks corresponding to the vanadium and boron, as well as the oxygen that quickly forms on its reactive surface, are easily identified. The two unshaded portions of the spectrum, corresponding to the oxygen and boron regions, are shown on an expanded scale in Fig. 8. These detailed spectra were taken under two conditions: the upper two traces show the oxygen, vanadium, and boron lines taken with electrons flooding the sample to neutralize sample charging effects (see box, this page), and the lower two traces are the same spectra without the flooding electrons.

The flooding electrons cause the two boron lines to coalesce, showing that there is only one chemical species of boron present, but that some of these atoms are electrically isolated from the bulk material. (Because they are isolated, the flooding electrons are needed to neutralize any potential these atoms acquire.) This information is quite significant, as will be shown.

Looking at the two vanadium peaks, it can be seen that these do not charge appreciably, that is, their positions are independent of the flooding electrons. This indicates that all of the vanadium atoms are in electrical contact with the bulk material.

The oxygen lines provide other information about the material. We can deduce that peak (C) is oxygen bound to the vanadium atoms and peaks (A) and (B) represent oxygen bound to the boron atoms by noting their relative shifts as the flooding electrons are supplied. Also, these spectra show that there are twice as many oxygen atoms bound to boron as to the vanadium, and that all the boron atoms have similar affinities for oxygen.

We thus have a rather complete picture of the surface composition of this compound, but how does this relate to its activity, the parameter of primary practical importance? To answer this question, a sample of the material was examined after it had been reacted and its activity substantially reduced. The flooding electrons no longer had an effect on any of the peaks, indicating that none of the boron atoms was electrically isolated from the bulk material any longer.

Studies of catalyst systems have shown that the charging shifts observed are also a function of catalyst activity, just as they are with the compound VB_2 . Hence charging shifts provide an empirical criterion for estimating catalyst efficiency, as well as being a valuable tool for studying the detailed

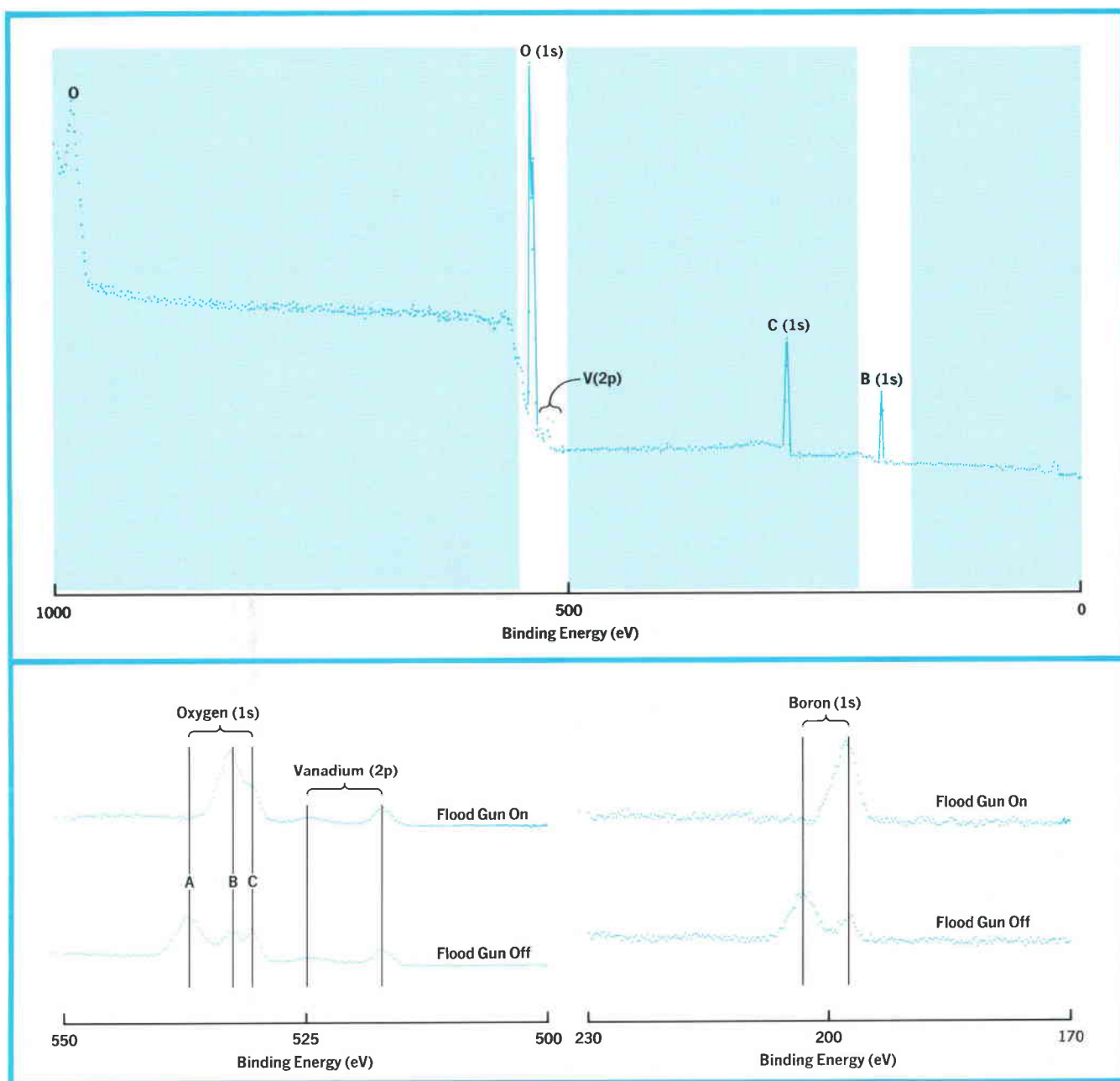

Fig. 8. Wide-scan and expanded ESCA spectra of VB_2 exemplify the use of ESCA in the study of catalysts. Shifts of peaks due to charging of the sample surface give valuable information about surface activity. Charging effect is turned off by supplying a flood of low-energy electrons to the sample surface.

mechanisms of surface reactions.

Factors influencing surface reactions, whether in a catalyst, an electrode in an electrochemical cell, or simply on a corroding surface are apparently quite subtle, as evidenced by the failure of more traditional analytical techniques to detect them. The HP spectrometer's ability to solve such problems is largely based on the monochromatic photon flux on the sample that minimizes sample damage and makes line shifts due to charging very evident, as well as the ability to turn these shifts off and on.

In addition, the sample handling system is ideally suited to analyze rapidly a large number of samples, as would be required for screening or quality control operations.

Sample Handling

Surface techniques, in contrast to many spectroscopic analyses of bulk materials, usually require that the sample to be analyzed be placed in a special environment: in the case of ESCA this environment is a good vacuum. Electrons escaping from a

solid at atmospheric conditions would travel only a few thousandths of an inch before being stopped by air molecules, so analysis of their energy would be impossible. To ensure that escaping electrons do not suffer undesired collisions in the spectrometer, they must be in an environment having a pressure of less than 10^{-9} atmosphere (about 10^{-6} torr). Moreover, if the sample is composed of a reactive material (aluminum, for example), the pressure must be even lower to prevent the surface being oxidized or otherwise contaminated. In such cases, the pressure of residual gases must be as low as 10^{-12} atmosphere (approximately 10^{-9} torr).

To enable a sample originally at atmospheric pressure to be conveniently placed in such a vacuum, a technique that requires less than 30 seconds to insert three samples has been developed for the 5950A ESCA Spectrometer. This is shown in Fig. 9.

Three samples are attached to a rod, which slides through four seals. As the samples pass the second of these seals, they are evacuated to about 10^{-5} atmospheres in a few seconds. They are then transported into the sample preparation chamber where the pressure is four orders of magnitude lower (approximately 10^{-7} torr). Here they can be cleaned by a beam of ions to remove layers of oxidation, or be otherwise prepared if desired.

The rod is then inserted farther into the main spectrometer chamber, and one of the three samples is placed in the proper position for analysis. The rod automatically positions the sample in the x-ray beam so the emitted electrons can enter the electron lens.

Analyzing the Sample

With the sample in position, the x-ray beam is turned on at a desired power between 100 and 1600 watts. The detector control unit, shown in Fig. 10, is set to the desired analysis conditions, and the analysis begun.

A number of analysis parameters can be selected including the range of energies to be scanned (from 10 to 1000 eV), the starting energy (0 to 1250 eV), the scan rate (1 to 10 eV/sec), and the number of scans. When the desired measurement is completed, the spectrometer shuts off and displays the results on the oscilloscope display (Fig. 10).

Accessories

Data System. To upgrade the signal processing and control functions of the spectrometer, a data system using an HP 2100A Computer and cassette storage is available. This system permits sequential analysis of selected spectral regions, data smoothing operations, and user-dedicated programming.

Variable Temperature Probe. A special sample rod permits samples to be analyzed at any desired temperature between -150°C and $+300^{\circ}\text{C}$. A controller is supplied with the probe that automatically regulates the sample temperature at the desired value.

Evaporation Probe. To study samples that are extremely reactive, it is desirable to prepare them in the spectrometer so they are never exposed to atmospheric conditions. To do this, a probe that permits samples to be vapor deposited on a substrate is available. Any material volatile enough to be

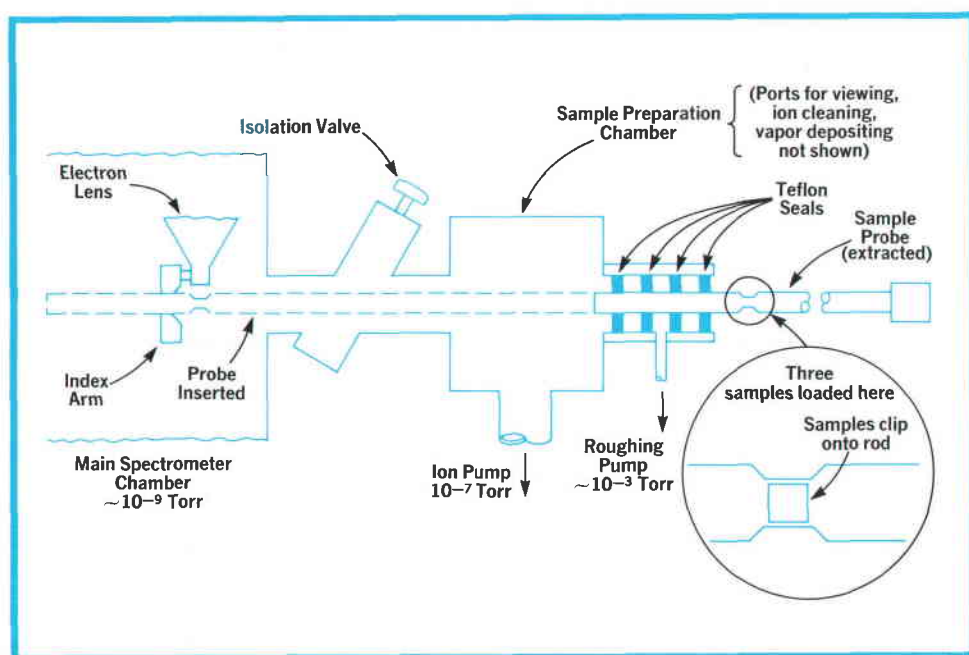

Fig. 9. Sample inlet system requires less than 30 seconds to insert three samples. Variable-temperature probe, evaporation probe, and ion gun are optional.

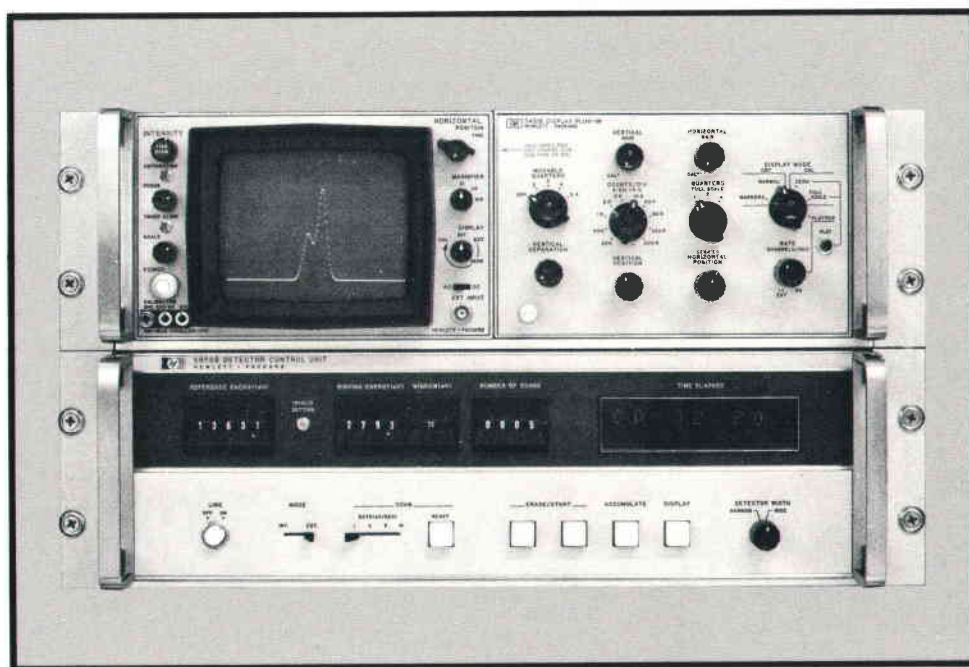

Fig. 10. Range of energies to be scanned, the starting energy, the scan rate, and the number of scans are selected at the detector control unit. The multichannel analyzer displays the resulting spectrum. Data can also be plotted or transmitted to a computer for analysis.

vaporized below 1700°C can be evaporated.

Flood Gun. This accessory permits the operator to neutralize the charging effects observed with insulating samples (see description of use, p. 10). It is supplied with a controller that allows both the energy and the number of flooding electrons to be varied.

Ion Gun. Samples can be cleaned to remove layers of oxide or other surface impurities with the accessory. It attaches to the sample preparation chamber so that the cleaned sample can be analyzed without exposure to air.

Acknowledgments

Design of the 5950A ESCA Spectrometer began as a project of Hewlett-Packard Laboratories. Dr. Kai Siegbahn conceived the principle of dispersion compensation and contributed to the total instrument design. Don Hammond and Hugo Fellner developed the crystal monochromator and the overall instrument philosophy. Bob Moody managed the program and supervised the design and construction of the first three prototypes. Rudy Meitzner developed the tooling and Ron Lackey and Henry Yoshida the processing of the monochromator crystals. Frank Barnett carried out a total system optimization and with Bill Kruger designed the electron lens. Harold Rocklitz and Harry Weaver extensively tested the electron lens, and Harry did further system development and testing. Vas Peickii, Larry LaBarre, John Vaught, and Walt Neumeier carried major mechanical design responsibility, ably assisted by Frank Bunya, Jerry Rector,

Paul Richert, Frank Adams, Bob Hansen, and Gaylen Grover. Don Norgaard developed much of the control and detection circuitry. Bill Kruger, Claus Hyllested and Clarence Blom contributed detection techniques and prototypes. Attilio Melera did early applications and marketing work.

At this point the 5950A was transferred to the Scientific Instruments Division. Many of the original designers went with it, joining others to form a team to complete the development and put the instrument into production. Harry Weaver as chief scientist and Attilio Melera developed a scientific understanding of the new technique and defined new areas of application. Gaylen Grover, Jerry Rector, Chuck Taylor, Harold Rocklitz, Frank Bunya, Don Jackson, and Larry Mauro continued the mechanical development of the analyzer and established production procedures. Roger Rauskolb, Tony Foster, Chet Haibel, Bill Peterson and Ken Pocek developed the present electronic components including lens supplies and signal processing system. Norton Bell developed the data system hardware. John Hearn supervised the overall engineering effort and Howard Harrington developed and implemented the marketing program.

Many others in addition to those just mentioned have contributed substantially to the development of the 5950A. Two people, however, deserve special acknowledgment: Don Hammond, in whose laboratory the project was begun, has lent it active and continuous support throughout its development, and Harry Weaver, who has been the technical and scientific mainstay of the project and has guided it through many difficult phases. 

SPECIFICATIONS

HP Model 5950A ESCA Spectrometer

RESOLUTION

UNSCANNED MODE

The full width at half maximum of the 1s level of carbon shall be 0.8 eV or less as determined by a 300 second measurement in the unscanned mode (window set to OFF) using a standard graphite calibration sample and an X-ray power of 800 watts. The baseline for the measurement shall be the signal level at a point 7 eV lower in binding energy than the peak.

SCANNED MODE

The full width at half maximum of the 1s level of carbon shall be 0.85 eV or less as determined by a measurement in the scanned mode (5 sweeps, 1 eV/sec, 10 eV window). Other measurement conditions shall be identical to those specified for the unscanned mode.

SENSITIVITY

The peak signal obtained from the 1s level of carbon in the scanned mode and with a clean X-ray anode shall meet or exceed the following:

Signal-to-background ratio:	200 to 1
Number of counts per channel (for total of 128 channels):	25,000
Signal-to-noise ratio:	1500 to 1

Noise is defined as the rms uncertainty in the number of counts per channel in the background. Background is defined as the signal measured at a point 7 eV lower in binding energy than the peak.

SPECTRUM ACCURACY

When calibrated with a sample at a known binding energy, the ac-

curacy of the entire energy scale from 0 to 999.9 eV binding energy shall be ± 0.1 eV (measured with a 10 eV window).

SPECTRUM STABILITY

After a 2-hour warmup, the spectrum is stable and reproducible to within $\pm 0.03 \pm 0.015 \Delta T$ eV during an 8-hour period, where ΔT is the ambient temperature change in $^{\circ}\text{C}$.

VACUUM

Without bakeout, the main chamber of the analyzer maintains a base pressure of 2×10^{-8} Torr or less in the Vaclon pump as determined from the pump current calibration curves (isolation valve #11 closed); the sample preparation chamber maintains a base pressure of 2×10^{-7} Torr or less in the Vaclon pump as determined from the pump current calibration curves.

SWEEP WIDTH

Selectable sweep width of 10, 20, 50, 100, 200, 500, and 1,000 eV. Energy calibration linear to within 0.3 percent of the selected sweep width ± 0.01 eV over the scan range.

SWEEP OFFSET

Sweep offset from 0.0 to 999.9 eV in 0.1 eV steps. Total binding energy displacement (sweep width plus sweep offset) will not exceed 1299.9 eV.

PRESETTABLE NUMBER OF SWEEPS: 1 to 9999.

PRESETTABLE SWEEP RATES: 1, 2, 5, and 10 eV per second.

OPERATING AMBIENT TEMPERATURE: +20 to +40 $^{\circ}\text{C}$.

PRICE IN U.S.A.: \$114,000 plus options.

MANUFACTURING DIVISION: SCIENTIFIC INSTRUMENTS DIVISION
1601 California Avenue
Palo Alto, California 94304 U.S.A.



Charles E. Tyler

Chuck Tyler is manager of the electron physics department of Hewlett-Packard Laboratories. He joined HP and the ESCA development team in 1969. His PhD degree in physics is from Washington University (1969) and his BS, also in physics, is from Massachusetts Institute of Technology (1964). He's authored three professional papers and four patent applications (now pending). Chuck's present work is a far cry from his early career, when he worked as a heavy machinery mechanic and welder, and later as a consultant on construction of a spectral array of henhouses! Married, and with two small children, Chuck is an outdoorsman who enjoys trout, salmon, and deep-sea fishing, duck and pheasant hunting, skeet, and table tennis.

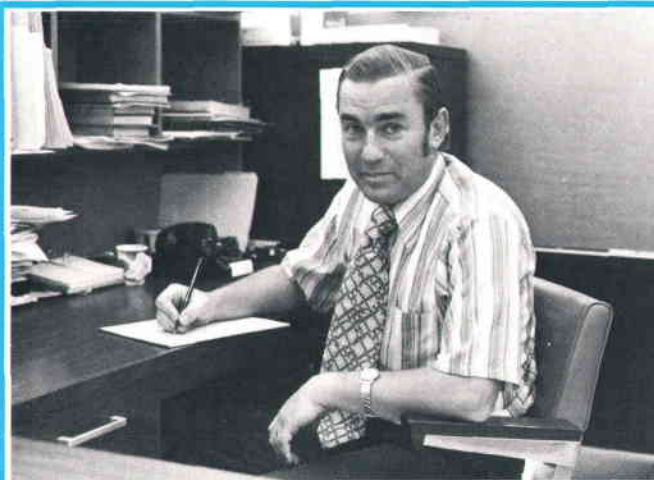

Michael A. Kelly

Mike Kelly is manager of ESCA research and development at HP's Scientific Instruments Division. He holds BS and MS degrees in electrical engineering and the PhD degree in physics, the BS from the University of California at Los Angeles (1959), the MS from Brooklyn Polytechnic Institute (1962), and the PhD from the University of California at Berkeley (1968). Mike joined HP Laboratories in 1968 and assumed his present position in 1972. He's the author of a dozen professional papers, the holder of two patents, a member of the American Physical Society, and an instructor in atomic theory at the University of Santa Clara. For the past few years he's also been an amateur enologist; in fact, he's just planted thirty vines in his back yard so he can grow his own grapes as well as produce his own wine.

Compact Function Generator with Enhanced Capability/Cost Ratio

A no-frills design plus a computer's help in verifying zero production defects brings the cost of this handy instrument down without sacrificing quality.

By E. Harry Heflin

IN THE SAME WAY that a multimeter is handy to have around for all sorts of everyday measurements, the function generator is useful to have as a general-purpose source of test signals (Fig. 1). The function generator's ability to supply sine waves for frequency response measurements, square waves for transient response testing, and triangular waves for trigger threshold measurements—and do these over a wide range of frequencies—has earned it a place among universal test instruments.

Recognizing the desire of nearly every electronics engineer and technician to have a function generator as part of his test and measurement lineup, and also the need that colleges and technical schools have for rugged and reliable signal sources that don't cost very much, we set out to design one that would be low-priced as well as versatile, but that would not compromise traditional HP quality (Fig. 2).

Such a program entails a number of engineering choices. First, we had to establish frequency range. We chose a range of 0.1 Hz to 1 MHz in seven decade bands, not as wide a range as some function generators but a range that spans the great majority of function generator uses in the sub-audio, audio, and ultrasonic ranges. A wider range would have incurred added cost that would be out of proportion to the added usability.

The second choice was output amplitude and impedance. The new generator (Model 3311A) produces up to 20V peak-to-peak into a high-impedance load from a 600 Ω output. Although it will no doubt be used to drive 50 Ω circuits as well as higher impedance loads, we chose 600 Ω because of the lower cost. It can supply 1V into a 50 Ω load, however, enough for most such applications. A 30 dB variable attenuator is included for lower level outputs.

One useful feature we felt could be included because of its modest incremental cost, was a separate 3-volt pulse output capable of driving 50 Ω or up to 20 TTL loads. In view of the fact that analog equipment these days very often includes some logic circuitry, the usefulness of the new Function Generator is enhanced by its ability to supply TTL-compatible clock pulses. The pulse output, which is referenced to ground, is also useful as a source of triggers for oscilloscopes or other instruments in the test setup.

Dc offset for the main output was another feature we included. This is useful in trigger threshold tests and also as a bias source for circuits driven by the Generator. We also isolated the circuit ground from chassis ground so that the output can be floated

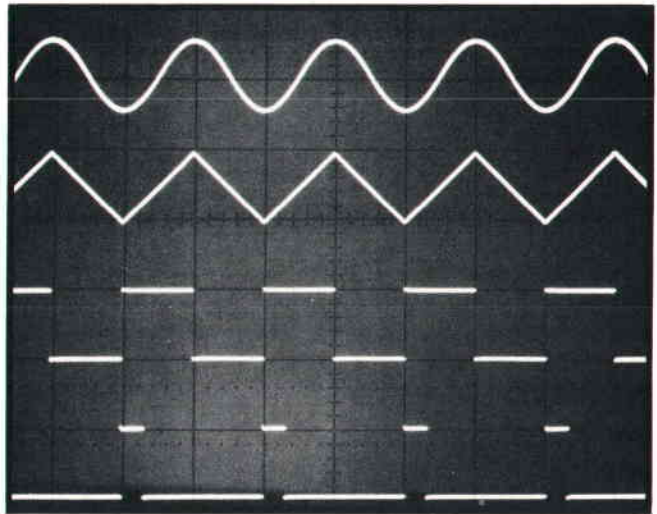

Fig. 1. Waveforms produced by new Model 3311A Function Generator as shown by triple-exposed oscillogram (frequency is 10 kHz). Pulse train (bottom trace) is available at a separate output simultaneously with any of the waveforms selected for the main output.

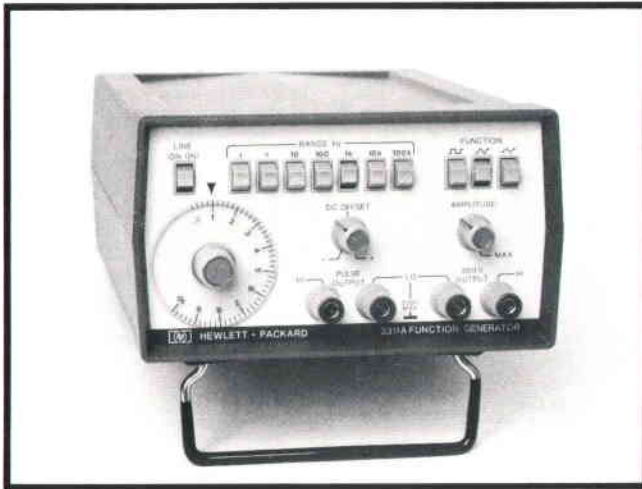

Fig. 2. New Model 3311A Function Generator supplies waveforms for many kinds of tests over 0.1 Hz to 1 MHz frequency range. Maximum output is 10V peak to peak into a 600 Ω load (20V into an open circuit). The amplitude control has a range of 30 dB.

up to $\pm 500V$ from chassis ground.

Another feature that was included at little expense was a VCO input (on the rear panel) for sweep-frequency testing or for frequency modulation of the output. With the FREQUENCY dial set to 1.0, a 0 to $-10V$ ramp at this input will sweep the frequency linearly from $\times 1$ to $\times 10$.

Keeping It Simple

A major objective in working out the circuit design was to simplify the circuitry wherever possible. As a result, the number of electronic components is small enough to allow all interconnections to be made with a single, two-sided board, avoiding the expense of a multi-layer board. In addition to that, the board layout was arranged to allow automatic insertion of the majority of components, another production cost-saver (Fig. 3).

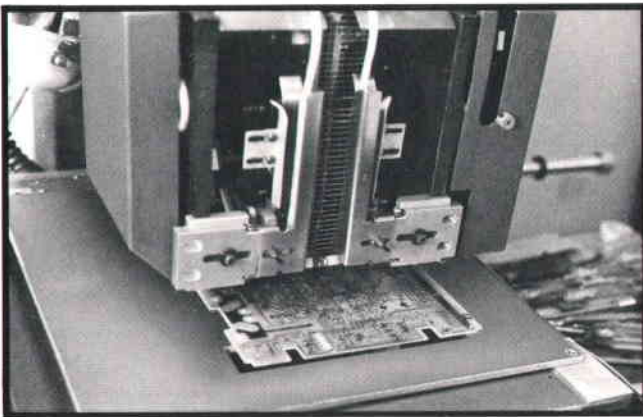

Fig. 3. Circuit-board layout aligned and spaced components to permit automatic insertion.

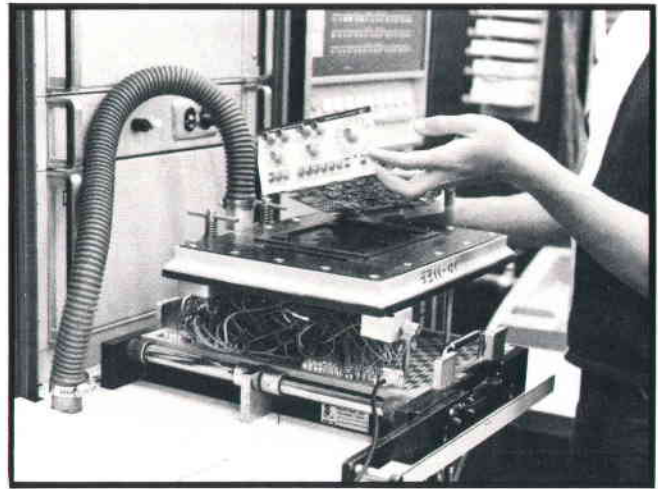

Fig. 4. Automatic test system quickly finds any production errors, reducing trouble-shooting time significantly. A vacuum holds the instrument on the test fixture and protruding component leads make contact through holes in the fixture.

The mechanical design also sought to reduce parts while at the same time simplifying assembly procedures. The "clam-shell" housing used for other HP low-cost instruments (5300-series Counters, 3470-series DVM's) fulfilled this objective admirably. Front and rear panels attach directly to the single circuit board and this assembly simply snaps into the rugged cast-aluminum housing. The instrument is completely functional when removed from the housing, simplifying test and repair.

A Computer Lends a Hand

Perhaps the most significant reduction in cost came from development of a computer-controlled test system that very quickly verifies the absence of production errors. The system exercises the completed circuit assembly and in the event that common production problems such as solder splashes, broken circuit-board traces, out-of-tolerance components, reversed diodes, and the like may exist, it identifies their nature and location (Fig. 4). It also finds marginal components that might later cause an instrument failure. The operator of the test system can quickly correct the indicated faults so the calibration technician does not have to spend hours tracking down elusive troubles. In addition to that, the instrument requires only nine adjustments for calibration, so each instrument needs to remain at the calibration station only a few minutes.

How It Works

As did the very first Function Generator (HP's venerable Model 202A¹), the new Model 3311A generates a triangular waveform by linearly charging and discharging a capacitor between fixed volt-

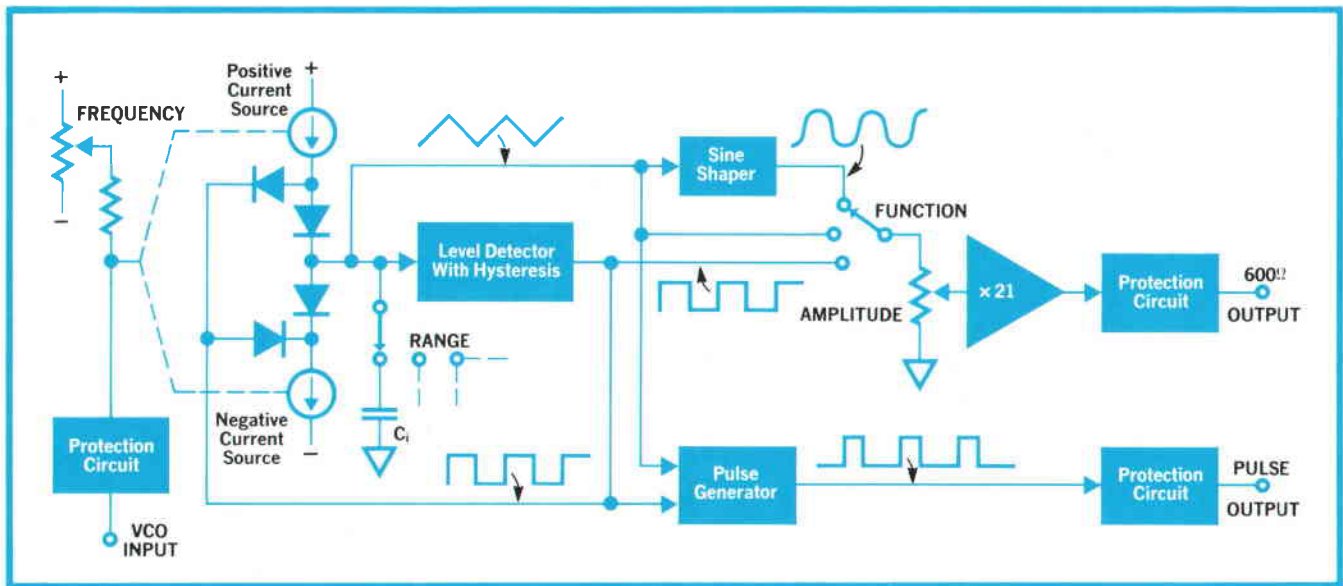

Fig. 5. Simplified block diagram of Model 3311A Function Generator.

age limits. A two-level voltage detector responds to the capacitor voltage and switches the direction of current flow when either voltage limit is reached. Thus, the detector generates a square wave. Sine waves are derived from the triangular waveform by a nonlinear network.

A block diagram is shown in Fig. 5. The square-wave output of the level detector switches the positive and negative current sources alternately to the integrating capacitor C_i . The resulting square and triangular waves, as selected by the FUNCTION switch, are passed on to the output amplifier through an attenuator that provides amplitude control.

Sine waves are derived in a circuit that differs from the ladder-type sine shaper used in other HP Function Generators. This one, shown in Fig. 6, uses two silicon diodes as clippers to flatten the

tops and bottoms of the triangular wave. Strings of germanium diodes, which have a "softer" clipping action, then round off the truncated triangles, shaping them into sine waves that have little harmonic distortion. Overall sine-wave distortion at the main output, typically less than 1%, is less than 3% over the full 0-to-55°C environmental operating range of the instrument.

The pulse output is derived by using the triangular waveform to shorten the time duration of the square wave's positive excursion. To do this, the triangular wave is applied to a comparator that triggers when the triangular wave is at 30% of peak amplitude (Fig. 7). This comparator's output is thus a pulse train in which each pulse spans the bottom 30% of the corresponding triangle.

The comparator output and the square wave are applied to an AND gate. This produces a pulse train

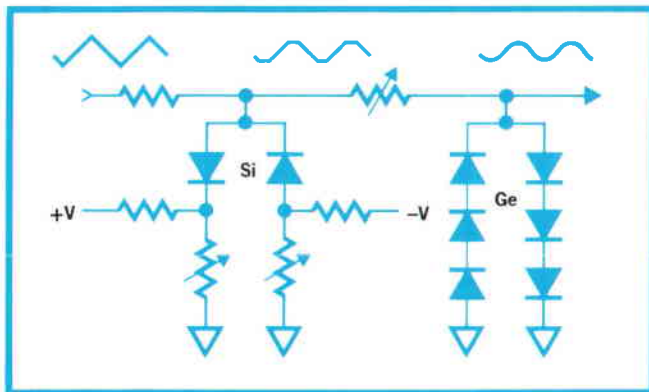

Fig. 6. New sine shaper converts the triangular wave into a low-distortion sine wave using fewer parts than earlier types of sine shapers.

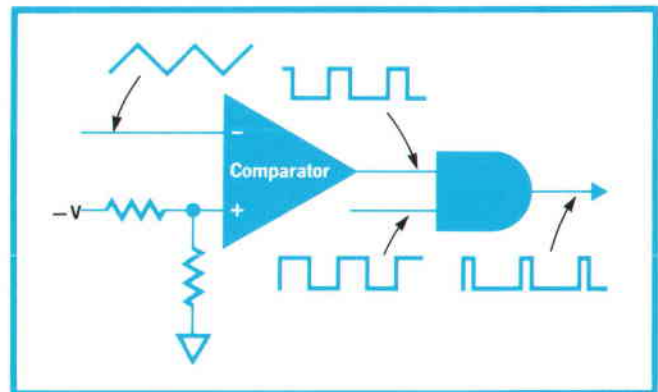
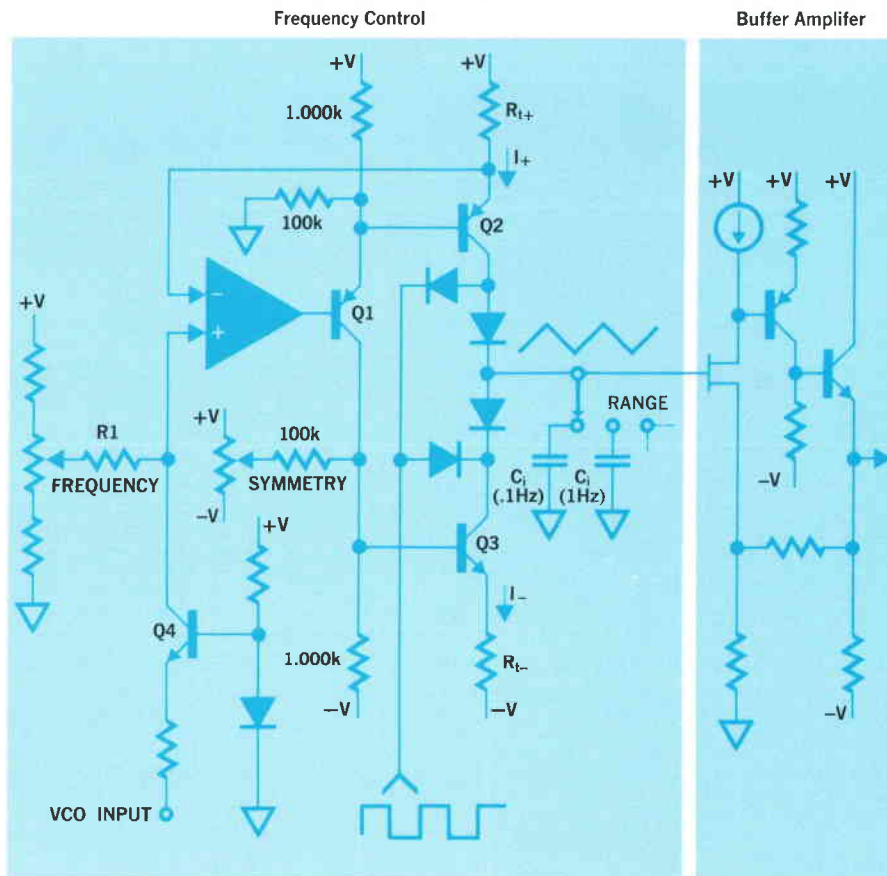

Fig. 7. Pulse generating circuit, using two low-cost IC's plus a few discrete components, derives pulses with a constant 15% duty cycle.

Low-Cost Function Generator Circuits

The output frequency of the Model 3311A is established by the choice of integrating capacitor C_i (RANGE) and by the setting of the FREQUENCY potentiometer (in the diagram below). Because of feedback from the emitter of Q2

A buffer amplifier is between the integrating capacitor C_i and the level detector. To preserve the linearity of the capacitor charge and discharge, this amplifier must have low input bias current and to prevent rounding of the peaks, it



back to the input, the voltage at the potentiometer slider is duplicated across timing resistor R_{t+} . This defines a current I_+ into the emitter of Q2. Q2 is a high-Beta, low-leakage transistor so its collector current is for all practical purposes the same as I_+ .

Resistor R_{t-} is matched within 0.1% to R_{t+} . Q1 is a differential driver so the potential drop across R_{t-} is equal to that across R_{t+} (any difference in the V_{BE} 's of transistors Q2 and Q3 is balanced out with the SYMMETRY control). The charging and discharging currents (I_+ and I_-) for capacitor C_i thereby remain within $\pm 0.5\%$ of each other over a 20-to-1 frequency tuning range.

must have wide bandwidth. As shown in the diagram above, this is accomplished with a J-FET at the input with negative feedback applied to the source. On the other hand, since the dc level of the output waveform is established by the level detector which follows, the amplifier does not need long-term dc offset stability. This amplifier contributes a gain of 2.

The level detector uses a monolithic IC comparator followed by a push-pull amplifier to increase the comparator's output to the 14V p-p swing needed to operate the diode switch. Positive feedback through R_f and R_g establishes the

that has a duration of about 15% of the waveform period with the leading edges coincident with the square wave, a convenience for synchronizing external equipment. Rise and fall transition times of the pulse train are typically 10 ns.

Just in Case

All inputs and outputs are protected against ac-

identally imposed external voltages by clamping diodes. In addition, the main output has a fusible resistor that protects the instrument, even against accidental application of 240V ac line voltages. This protection will be of special interest to those considering the instrument for use in student labs or in other applications involving inexperienced personnel.

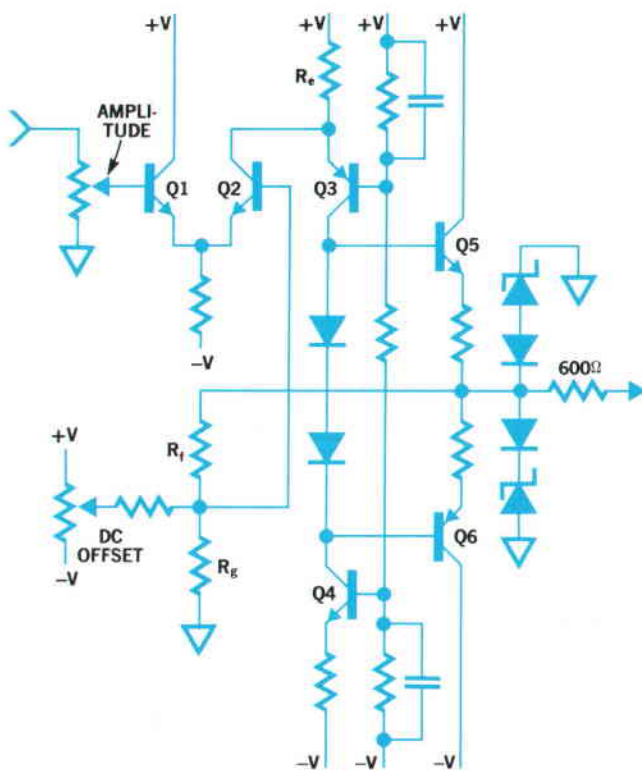
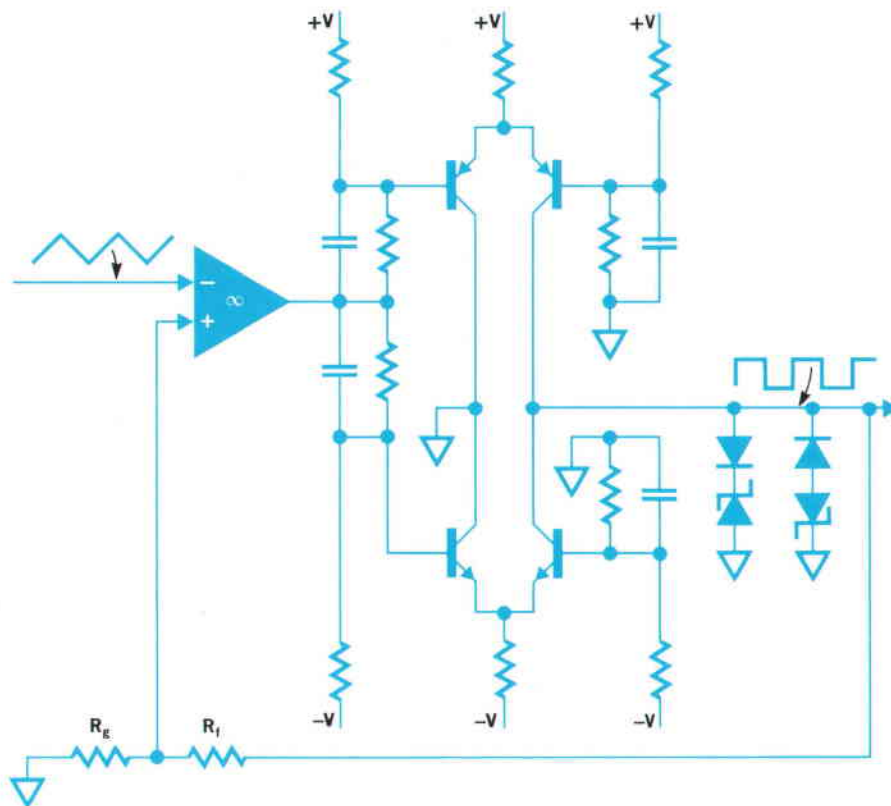

two voltage levels for the comparator shown above. This circuit minimizes the loop delay that, by delaying switching time, would result in an increase in the triangular waveform amplitude at high frequencies with a consequent error in frequency. As a further guard against amplitude changes, temperature-compensated Zener diodes clamp the output voltage excursions to maintain a constant square wave amplitude.

Because of the balanced, push-pull circuit configuration, the current drawn from the power supplies remains constant throughout the waveform period. This minimizes high-frequency perturbations that otherwise might be coupled to other circuits through the power supplies.

The output amplifier (see diagram left) uses a balanced configuration that causes no current flow into the load when the voltage at the input is at the baseline level. Half the current through resistor R_e then flows through transistor Q2 and half through Q3 down through Q4.

Transistors Q3 and Q4 function as constant-current sources. A change of voltage at the input unbalances the division of R_e current, and current then flows in the load. Negative feedback through R_f and R_g sets the gain at 21.

A differential stage is used at the input to minimize offsets and drift. Offsets can be set intentionally, however, through use of the DC OFFSET control.

The Zener diodes at the output clamp the Q5-Q6 emitters at a safe voltage level if an excessive external voltage is applied to the output terminal. Similar arrangements for circuit protection are found at the Pulse Output and at the VCO Input.

Acknowledgments

Product design was by Ed Pennington. Special thanks are due Noel Pace and Bob Dudley for their counsel and guidance throughout the project.

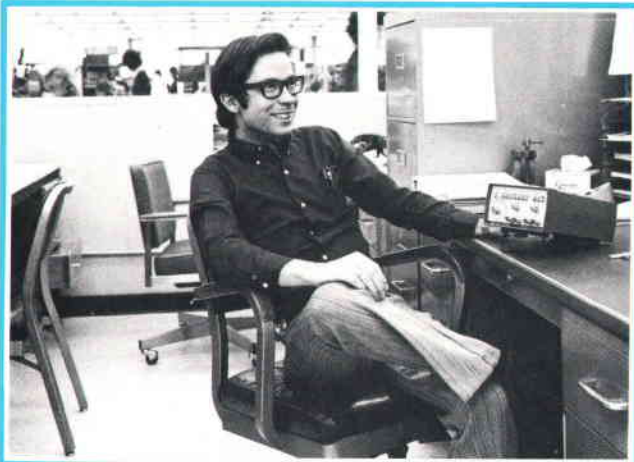

E. Harry Heflin

A tour of duty in Korea as a Division Radio Officer resulted from Harry Heflin's involvement in ROTC while in college (BSEE Purdue University, 1968). On leaving the service (1970), Harry joined HP (he had worked as an HP summer employee while in college). Initially, he worked on the 3431A Digital Panel Meter, then he assumed responsibility for the 3311A Function Generator, all the while working towards an advanced degree in the HP Honors Co-op Program (MSEE Colorado State University, 1972).

Photography is one of Harry's hobbies and he combines that with a liking for hiking and camping in the mountains to get pictures of wildflowers and the splendid vistas that he and his wife encounter. At home, he spends time on a vegetable garden to satisfy a yen for that fresh-off-the-vine flavor.

References

1 R. H. Brunner, "A New Generator of Frequencies Down to 0.01 CPS," Hewlett-Packard Journal, June 1951.

SPECIFICATIONS

HP Model 3311A Function Generator

600 Ohm Output

WAVEFORMS: sinusoid, square, and triangle.

FREQUENCY RANGE: 0.1 Hz to 1 MHz in seven decade ranges.

DIAL ACCURACY: $\pm 5\%$ of full scale.

MAXIMUM OUTPUT AMPLITUDE: 20 V p-p open circuit; 10 V p-p into 600 Ω .

AMPLITUDE CONTROL: continuously variable, >30 dB range.

OUTPUT IMPEDANCE: 600 Ω $\pm 10\%$.

DC OFFSET: up to ± 10 V open circuit, ± 5 V into 600 Ω , continuously adjustable and independent of amplitude control. Maximum V ac peak + V dc offset without clipping is ± 10 V open circuit, ± 5 V into 600 Ω .

ISOLATION: outputs may be floated up to ± 500 V relative to instrument case (earth ground).

SINE WAVE AMPLITUDE FLATNESS: within $\pm 3\%$ of 10 kHz reference to 100 kHz at maximum output amplitude, $\pm 6\%$ to 1 MHz.

SINE WAVE TOTAL HARMONIC DISTORTION: <3% at maximum output amplitude.

TRIANGLE LINEARITY: deviation <1% from best straight line at 100 Hz (maximum output amplitude).

SQUARE WAVE TRANSITION TIME: <100 ns.

SQUARE WAVE TIME AXIS SYMMETRY ERROR: $\pm 2\%$ maximum to 100 kHz.

Pulse Output

OUTPUT AMPLITUDE: >3 V positive (open circuit) TTL compatible.

DUTY CYCLE: 13.5% to 16.5% of total period.

TRANSITION TIMES: <25 ns.

External Frequency Control

VCO RANGE: >10:1 on any frequency range.

INPUT REQUIREMENT: with frequency dial set to 1.0, linear ramp of 0.0 V to -10 V ± 2 V increases frequency linearly >10:1.

INPUT IMPEDANCE: 10 k Ω $\pm 10\%$.

General

OPERATING TEMPERATURE: 0°C to 55°C. Specifications apply from +15°C to +35°C.

POWER: 100/120/220/240 V -10% , +5% switchable; 48 Hz to 440 Hz; ≤ 12 VA.

DIMENSIONS: 6 $\frac{1}{4}$ in W x 3 $\frac{1}{2}$ in H x 9 $\frac{3}{4}$ in D (15.9 x 8.9 x 24.8 cm).

WEIGHT: net 3 $\frac{1}{2}$ lbs (1.5 kg).

PRICE IN U.S.A.: \$249.

MANUFACTURING DIVISION: LOVELAND DIVISION
815 Fourteenth Street, S.W.
Loveland, Colorado 80537

Address Correction Requested:

Hewlett-Packard Company, 1501 Page Mill Road, Palo Alto, California 94304

Bulk Rate
U.S. Postage
Paid
Hewlett-Packard
Company

HEWLETT-PACKARD JOURNAL

JULY 1973 Volume 24 • Number 11

Technical Information from the Laboratories of
Hewlett-Packard Company

Hewlett-Packard S.A., CH-1217 Meyrin 2
Geneva, Switzerland

Yokogawa-Hewlett-Packard Ltd., Shibuya-Ku
Tokyo 151 Japan

Editorial Director • Howard L. Roberts
Managing Editor • Richard P. Dolan
Contributing Editors • Ross H. Snyder,
Laurence D. Shergalis

Art Director, Photographer • Arvid A. Danielson
Art Assistant • Sue M. Reinheimer
Administrative Services • Anne S. LoPresti
European Production Manager • Kurt Hungerbühler

CHANGE OF ADDRESS: To change your address or delete your name from our mailing list please send us your old address label (it peels off). Send changes to Hewlett-Packard Journal, 1501 Page Mill Road, Palo Alto, California 94304 U.S.A. Allow 60 days.

HP Archive

This vintage Hewlett-Packard document was
preserved and distributed by

www.hparchive.com

Please visit us on the web!

On-line curator: John Miles, KE5FX

jmiles@pop.net

