

JUNE 1973

# HEWLETT-PACKARD JOURNAL

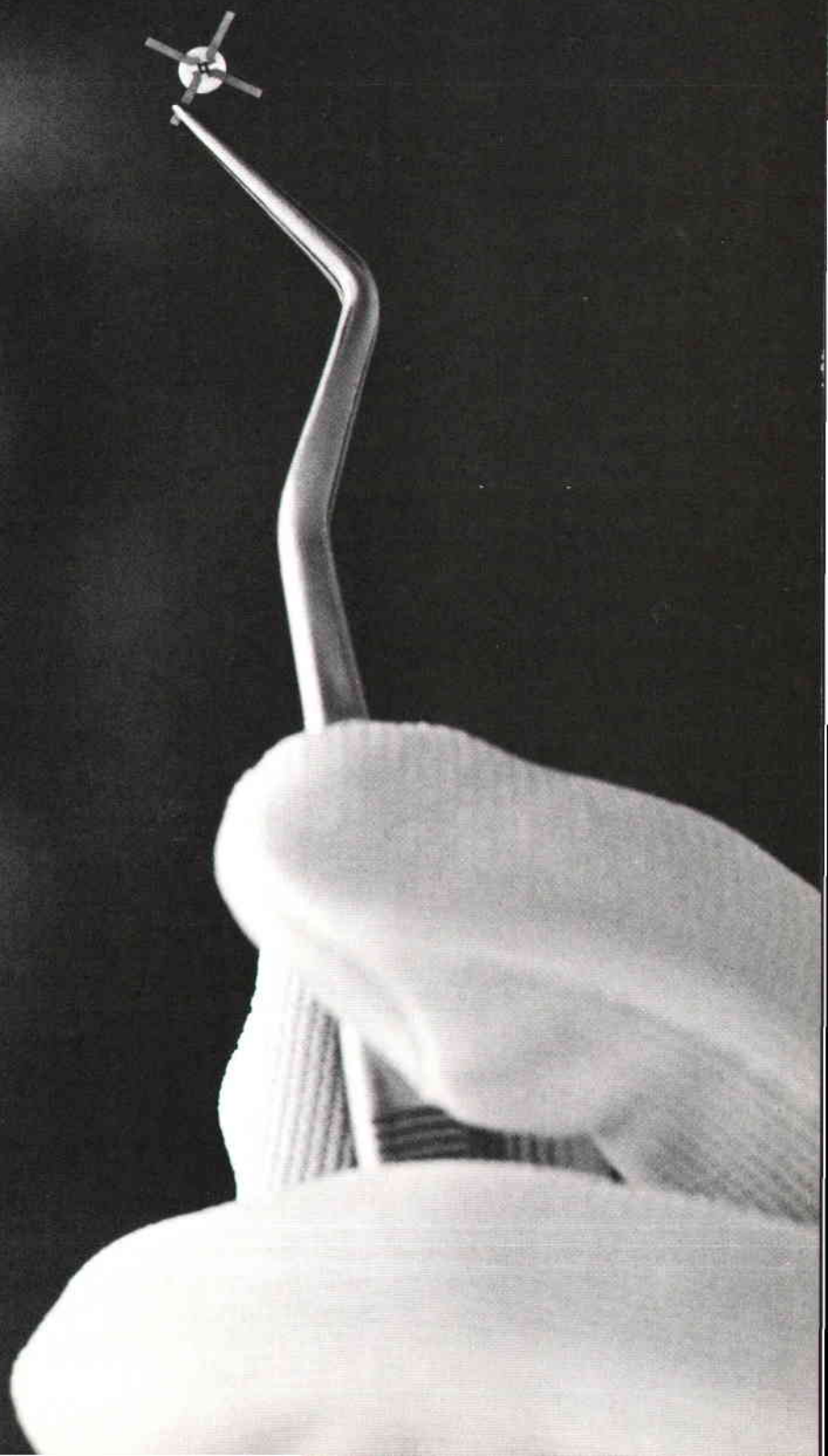

# Schottky-Barrier Diodes Structured for Better High-Frequency Performance

Connecting discrete components into thin-film hybrid circuits becomes increasingly difficult as the demand for higher frequencies gives rise to smaller components. Described here is a way of fabricating diodes to gain high frequency performance without imposing severe mechanical limitations.

by Jack H. Lepoff and Raymond A. Morris

**A**S THE USE OF THIN-FILM HYBRID MICRO-CIRCUIT techniques rapidly expands, the microscope and vacuum pickup become as common in the production department as the soldering iron. Handling the discrete components used in these circuits becomes more and more of a problem as the quest for higher frequency performance shrinks the size of the components.

One of the major problems involves the attachment of wire leads to a semiconductor chip: not only is it a very delicate task to position a lead, but the heat and pressure needed to attach the lead could affect the characteristics of the device. The circuit assembler thus steers a narrow course between defective bonds from insufficient heat and pressure, and defective devices from too much heat and pressure.

Hence the growing popularity of beam-lead devices<sup>1</sup>. These may be supported by their own leads and can thus be installed by thermo-compression bonding of the leads alone to the substrate conductors. No heat or pressure is applied to the semiconductor chip itself.

But, as efforts to gain even higher frequency performance trims dimensions, it becomes increasingly difficult for the component manufacturer to find ways of providing a firm anchor for the beam leads. This problem has been overcome at Hewlett-Packard by the prudent use of glass, resulting in new beam lead diodes that perform exceptionally well in mixer service at microwave frequencies but that can be installed with little likelihood of damage to the semiconductor. These diodes also perform advantageously in digital hybrid integrated circuits.

## Diode Construction

Structural details of the new diodes are shown in the cross-sectional view of Fig. 1. Construction

starts with a highly doped  $n^+$  silicon wafer on which an n-doped layer is grown epitaxially. The doping density and thickness of this epitaxial layer largely determine the electrical properties of the diode.

Mesas about 25 microns high are etched on the wafer surface by conventional photoresist techniques and a silicon dioxide ( $SiO_2$ ) layer is then deposited. Next, a connection point for the cathode is



**Cover:** The tweezers hold a new monolithic silicon-on-glass diode quad — four Schottky-barrier diodes arranged in a ring configuration (shown prior to encapsulation) for double-balanced mixer service. This construction achieves better matching and lower parasitics than has been possible with discrete components. For a description of this and another interesting diode development, see the article beginning on this page.

## In this Issue:

- Schottky-Barrier Diodes Structured for Better High-Frequency Performance*, by Jack H. Lepoff and Raymond A. Morris ..... **page 2**
- DMM and DAC Modules Expand Low-Cost Measuring System*, by James F. Horner, Lewis W. Masters, and P. Thomas Mingle ..... **page 7**
- Laser/Calculator System Improves Encoder Plate Measurements*, by Glenn O. Herreman ..... **page 16**
- Instrument Basics Without Pain*, a book review ..... **page 19**

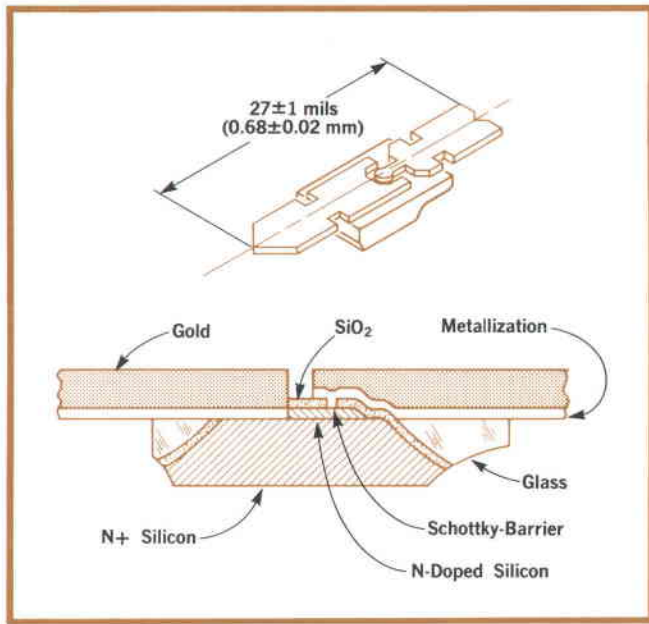
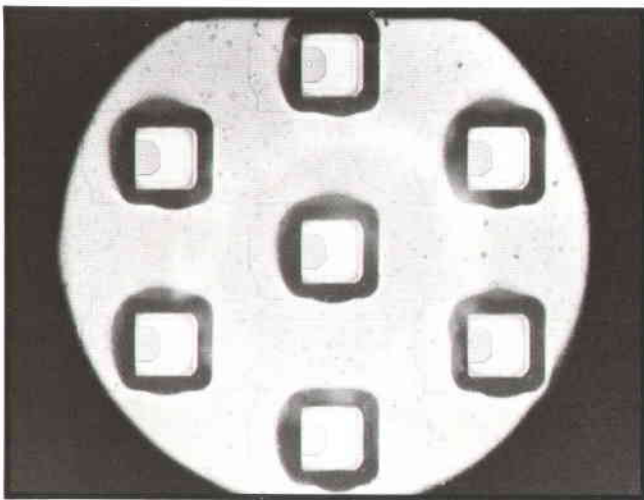

**Fig. 1.** New Schottky-barrier diodes have leads that can support the diode when thermocompression bonded into a thin-film, hybrid microcircuit. Although leads are tissue-paper thin, they are relatively rugged in relation to size. Cross-section shows details of diode construction.

exposed by etching away part of the mesa, and overlying  $\text{SiO}_2$  layer, to the  $n^+$  substrate.

This is followed by deposition of a layer of glass dielectric around the mesas. Then the anode window is etched through the oxide layer, as shown in Fig. 2. The hole for the anode may be as small as 8 microns in diameter for very high frequency applications.

Next, metallization is vacuum deposited over the



**Fig. 2.** Microphoto of part of a silicon wafer after the anode windows have been formed. The dark shadow around each device results from the sloping sides of the mesa. The area between mesas is filled in with low-dielectric glass.

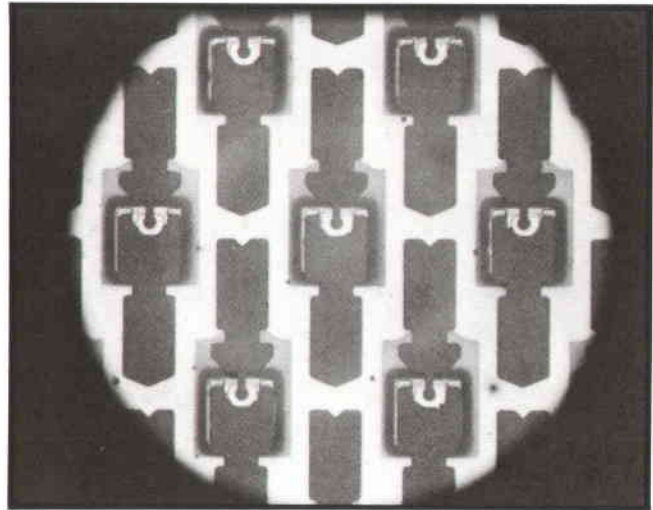

**Fig. 3.** Silicon wafer before final separation of diodes. Each wafer has about 5000 diodes.

entire wafer, forming in one step the Schottky-barrier anode, the ohmic cathode contact, and a glass-to-metal bond for lead attachment. Using a photoresist mask as a pattern, beam leads are formed by electroplating high-purity gold on the metallization. Excess metallization is then etched from the wafer surface, leaving the diode structure as shown in Fig. 3.

Finally, the wafer is mechanically and chemically thinned and then masked and etched to form the silicon chips, to separate the devices, and to clear the beam leads. Enough glass remains around each chip to provide an anchor for the leads without adding significantly to parasitic capacitance.

#### Performance

These diodes are very small, less than 0.03 inch (0.7 mm) from head to tail. Fig. 4 gives an idea of their minuteness. Lead inductance is thus only 0.1 nH, actually less than that obtained with a wire lead bonded between thin-film conductor and semiconductor chip. With lead capacitance of only 0.02 pF, this low inductance assures good performance in microwave circuits. The low parasitic reactances also simplify the design of matching elements for broadband applications.

The very small size of the metal-semiconductor junction results in a junction capacitance of 0.11 pF in the type 5082-2709 diode, useful up to 12.4 GHz, and only 0.09 pF in the type 5082-2716 which is useful up to 18 GHz. Typical admittance characteristics are shown in Fig. 5.

Typical noise figure, nominally 6 dB, is shown in Fig. 6. This is close to the state of the art for silicon diodes in microwave mixer service. For detector applications, typical tangential sensitivity is  $-54$  dBm. Minimum breakdown voltage is 3V.

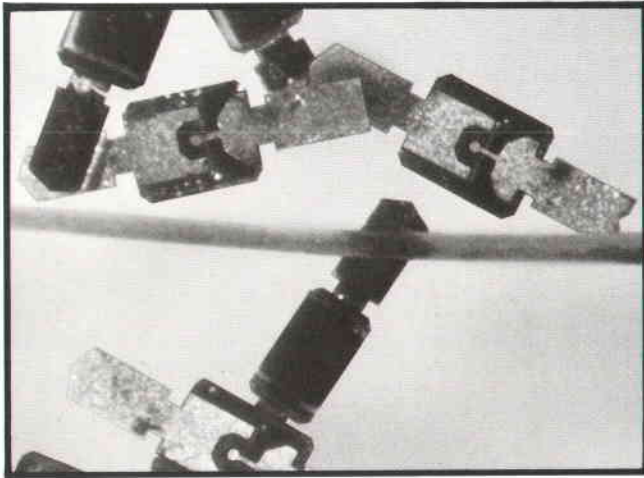

**Fig. 4.** Small size of new diodes is depicted by this micro-photo of diodes alongside human hair that has 3 mil (75  $\mu\text{m}$ ) diameter.

### Testing

Evaluating the performance of devices this small poses additional problems. Because of the close similarities between diodes fabricated on the same wafer, it is usually sufficient to bond sample quantities into circuits for determining impedance characteristics and a noise figure representative of the whole batch.

In some applications, however, it may be necessary to test every diode. Contact to the diode must then be made without damaging the leads. The small size of the leads on these diodes makes it impractical to use dielectric rods to hold the leads on microstrip conductors, a technique commonly used with other devices. Instead a small hole drilled in the microcircuit substrate allows a vacuum to hold the diode. The test circuit is shown in Fig. 7.

### Diode Quad

The same construction steps are used to fabricate

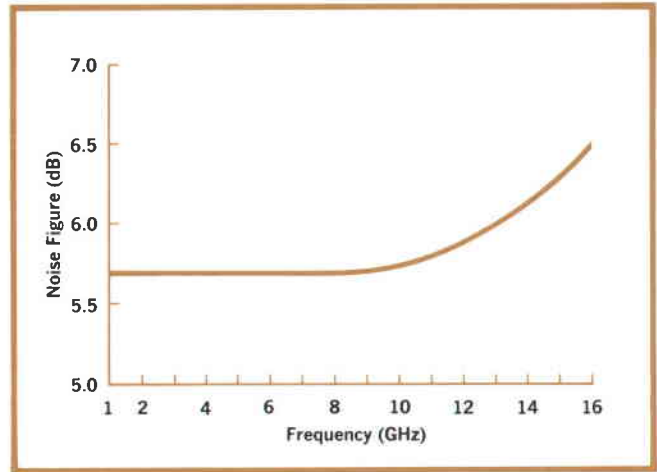

**Fig. 6.** Noise figure of HP type 5082-2709 diode as a function of frequency.

a silicon-on-glass, four-diode array for double-balanced mixer service. In this case, the metallization pattern is altered to make the diode interconnections, the length of each interdiode conductor then being only 20 mils. The final separation step leaves four interconnected diodes on a single glass substrate.

For convenience in mixer applications, the diode quad is mounted in a lead-frame package that can be soldered into a circuit without a microscope, using conventional techniques. The leads can withstand a temperature of 235°C for five seconds (according to MIL-STD-202, method 208), and they can be bent, permitting a variety of mounting arrangements.

During diode assembly, the lead frame is held in a fixture that also holds a ceramic wafer. The leads of the diode quad are welded to the lead frame, as shown in Fig. 8, and the assembly is then covered with epoxy resin. The resulting package is shown in Fig. 9.

This package passes the 85% relative humidity/

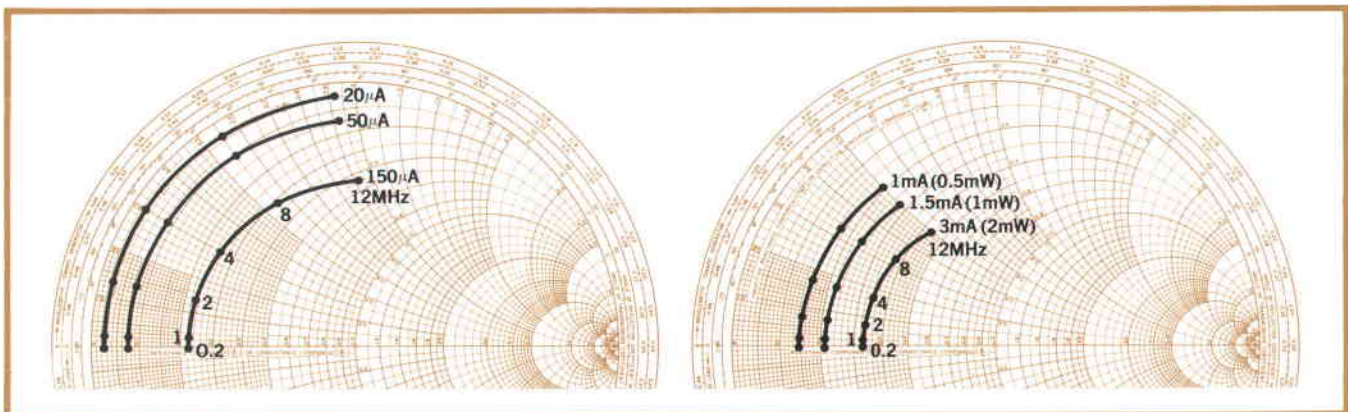

**Fig. 5.** Smith charts show typical admittance characteristics of representative diode.

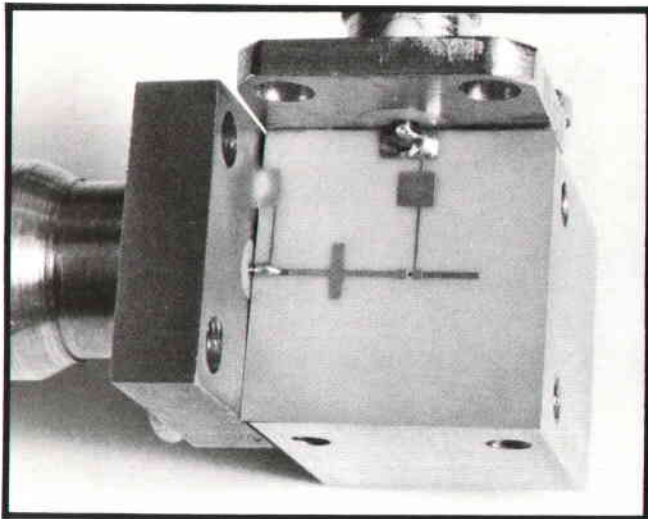
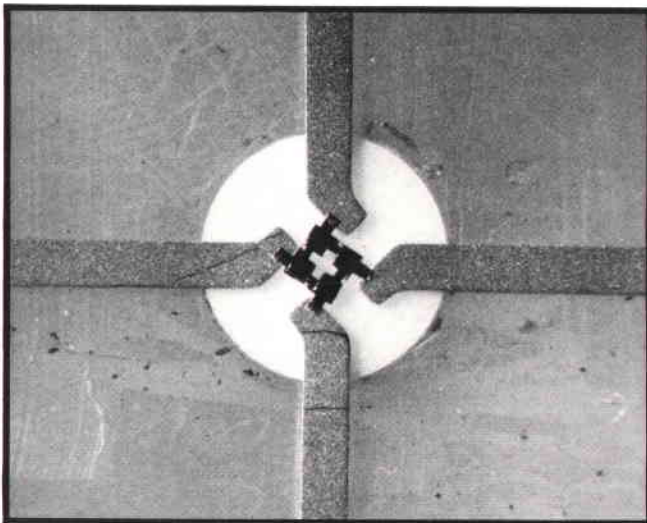

**Fig. 7.** Thin-film test circuit for evaluating diode performance. Vacuum applied through the small opening holds the diode in place. Impedance matching is provided by the open-ended shunt transmission lines and open-ended line to the right of the opening.

85°C moisture resistance test of MIL-STD-202, Method 106, yet it is inexpensive and lends itself well to automated high-volume production.

#### Quad Performance

The low parasitic inductance and capacitance of the diode quad allows broadband performance up to 2 GHz and tuned performance to 12.4 GHz. The diodes are inherently well matched—capacitances of the individual diodes differ by less than 0.1 pF and voltage drops between pairs of adjacent leads differ by less than 20 mV with 5 mA current flowing, assuring low distortion. Furthermore, temperature gradients are small—temperature tracking is far better than that achievable with discrete diodes.



**Fig. 8.** Diode quad is thermocompression bonded to lead frame then covered with epoxy resin.



**Fig. 9.** Completed diode quad can be installed in circuits by conventional soldering techniques.

#### Conversion Loss Test Fixture

The basic double-balanced mixer circuit shown in Fig. 10 has been realized at microwave frequencies in a number of configurations. For example, commercially available 180° hybrids can be substituted for the transformers. Such an arrangement is used in the test circuit for evaluating conversion loss.

#### Acknowledgments

Mike Hu designed the lead-frame package for the diode quad. We also wish to acknowledge the contributions of Neil Corpron and Frank Lee, who designed the test circuits.

#### References

1. M. P. Lepselter, "Beam-Lead Technology," Bell System Technical Journal, February 1966.

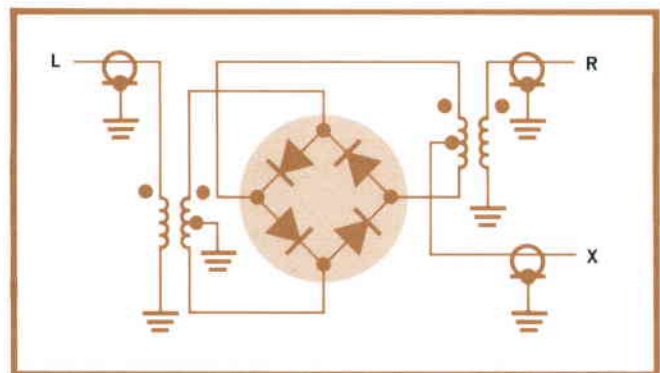

**Fig. 10.** Prototypical double-balanced mixer circuit using HP type 5082-2276 diode quad. Conversion loss test fixture uses commercially available 180° hybrids in place of the transformers with tuning elements to eliminate reflections and bias tees to separate the IF output from the input.

## SPECIFICATIONS

### HP Types 5082-2709, -2716, -2768, and -2769 Schottky-Barrier Diodes (@ $T_A = 25^\circ\text{C}$ )

	5082-2709	5082-2768	5082-2716	5082-2769	Test Conditions
MINIMUM VOLTAGE BREAKDOWN ( $V_{BR}$ ):	3V				$I_R = 10\mu\text{A}$
MAXIMUM FORWARD VOLTAGE ( $V_F$ ):	1V				$I_F = 20\text{mA}$
MAXIMUM TOTAL CAPACITANCE ( $C_T$ ):	0.25pF		0.15pF		$V_R = 0\text{V}$
NOISE FIGURE ( $NF_{SSB}$ ):	6dB typ	6.5dB max	7.5dB typ	7.5dB max	LO Pwr = 1mW $I_F = 30\text{MHz}$ , 1.5dB
TYPICAL TANGENTIAL SENSITIVITY (TSS):	-54dBm				Video BW = 2MHz
FREQUENCY RANGE:	Up to 12.4GHz		Up to 18GHz		
OPERATING TEMPERATURE RANGE:	-60 to +150°C				

### Typical Circuit Parameters

JUNCTION RESISTANCE ( $R_j$ ):	230Ω	230Ω	@LO pwr = 1mW, dc load resistance < 10Ω on 10 mil substrate
JUNCTION CAPACITANCE ( $C_j$ ):	0.11pF	0.09pF	
SERIES RESISTANCE ( $R_s$ ):	5Ω	6Ω	
PACKAGE INDUCTANCE ( $L_p$ ):	0.09nH		
PACKAGE CAPACITANCE ( $C_p$ ):	0.02pF		

### HP Types 5082-2276, -2277, -2830 Schottky-Diode Quads (@ $T_A = 25^\circ\text{C}$ )

	5082-2276	5082-2277	5082-2830	Test Conditions
TYPICAL FORWARD VOLTAGE ( $V_F$ ):	0.40V	0.45V	0.40V	$I_F = 1\text{mA}$
FORWARD VOLTAGE UNBALANCE ( $\Delta V_F$ ):	20mV max.			$I_F = 5\text{mA}$
MAXIMUM CAPACITANCE ( $C_T$ ):	0.60pF	0.40pF	—	$V_R = 0\text{V}$ $f = 1\text{MHz}$
MAXIMUM CAPACITANCE UNBALANCE ( $\Delta C_T$ ):	0.10pF		0.20pF	$V_R = 0\text{V}$ $f = 1\text{MHz}$
MAXIMUM DYNAMIC RESISTANCE ( $R_D$ ):	15Ω	20Ω	—	$I_F = 5\text{mA}$ dc $+ 0.02\text{mA}$ ac
TYPICAL NOISE FIGURE ( $NF_{SSB}$ ):	6.0dB	6.5dB	—	
FREQUENCY RANGE:	Up to 4GHz	Up to 12.4GHz	Up to 2GHz	
DC POWER DISSIPATION:	75mW per junction @ $T_A = 25^\circ\text{C}$ ; derate linearly at 0.75mW/°C			
OPERATING TEMPERATURE RANGE:	-65 to +125°C			

SINGLE UNIT PRICES IN U.S.A.:	5082-2709*, \$ 5.75	5082-2276, \$ 18
	5082-2716, \$ 9.50	5082-2277, \$34.50
	5082-2768, \$ 9.50	5082-2830, \$ 6.50
	5082-2769, \$12.50	

\*Minimum order for 5082-2709: 10 units

MANUFACTURING DIVISION: HPA DIVISION  
620 Page Mill Road  
Palo Alto, California 94304

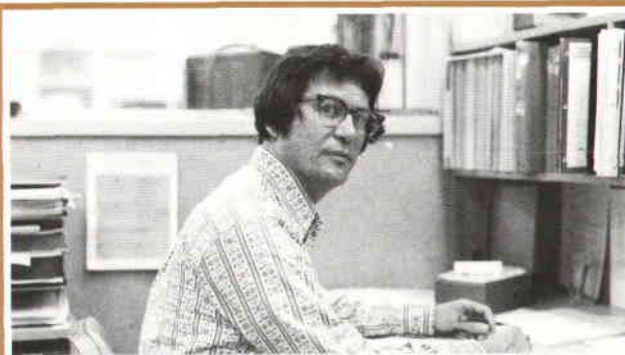

### Jack H. Lepoff

On earning a BS degree in Physics from the University of New Hampshire (1943), Jack Lepoff received his commission in the U.S. Navy and was assigned to microwave component and antenna development at the Naval Research Laboratory. Then it was Columbia University and an MA in Physics, 1948, and work on microwave devices for several industrial and government laboratories.

Jack joined HP in 1965. Initially he developed techniques for characterizing microwave mixer diodes, then he designed integrated Coaxial Mixers and Limiter/Detectors in the 33800 series. He now is a diode applications engineer.

With both daughters now grown and on their own, Jack finds time to devote to amateur theatricals with the Sunnyvale Unitarian Fellowship's theater group.



### Raymond A. Morris

Wood carving is only one of Ray Morris's spare time activities. A determined jogger, he enters the annual 8-mile San Francisco Bay-to-Breakers foot race, supposedly the world's largest (2500 entrants). In between times he skin-dives with his son, who is pursuing a PhD in marine biology.

Ray has been a semiconductor process engineer ever since he left college in 1950 (BS and MS degrees in Chemical Engineering, University of Washington). He started on selenium rectifiers, moved on to fast switching diodes, then joined HP's fledgling voltmeter detector diode operation in 1958. He also worked on voltage-reference and step-recovery diodes before going on to Schottky-barrier diodes.

Ray has a daughter who also works at HP and his wife, a holder of a BS in Physics, is a senior reliability engineer at Lockheed.

# DMM and DAC Modules Expand Low-Cost Measuring System

*A five-digit multimeter/counter module and a three-digit digital-to-analog converter module are new members of the 5300 Measuring System joining the mainframe, battery pack, and four timer/counter modules previously available.*

**by James F. Horner, Lewis W. Masters, and P. Thomas Mingle**

**A**LTHOUGH BASICALLY A COUNTING SYSTEM, the 5300 Measuring System, as its name implies, isn't limited to counter measurements. The 5300A mainframe, with its six-digit 10 MHz counter, counts a signal presented to it by the snap-on functional module, which contains circuits for function selection and signal shaping. Therefore, any quantity that can be converted to an appropriate frequency by a snap-on module can be measured by the mainframe.

The first four snap-on modules were designed for counter-timer measurements. The newest, Model 5306A Multimeter/Counter (Fig. 1), is the first to apply the inherent flexibility of the mainframe to other types of measurements. It offers functions of dc volts, ac volts, ohms, and frequency, all the functions usually found in digital multimeters plus an extra one, frequency.

Another new module, Model 5311A Digital-to-Analog Converter, fits between the mainframe and the snap-on functional module. It converts any three digits of the 5300A display to a proportional analog voltage output. It can be used with any snap-on module, and with or without the 5310A Battery Pack, which is also an "in-between" module. The design of Model 5311A is described on page 11.

## Four-Digit Accuracy, Five-Digit Resolution

Model 5306A Multimeter/Counter measures dc voltage in three ranges:  $\pm 10$  V,  $\pm 100$  V, and  $\pm 1000$  V full scale. Ac voltage is measured in ranges of 10 V, 100 V, and 1000 V, and resistance-measurement ranges are 10 k $\Omega$ , 100 k $\Omega$ , and 10 M $\Omega$  full scale.

Accuracy specifications are essentially those of a four-digit multimeter. However, for reasons to be explained later, Model 5306A's fifth digit is a full digit, not just an overrange digit, so measurement resolution and dynamic range are those of a five-



**Fig. 1.** Two new modules for the 5300 Measuring System are Model 5306A Multimeter/Counter (bottom module of instrument in foreground) and Model 5311A Digital-to-Analog Converter (center module). The Multimeter/Counter measures dc voltage, ac voltage, resistance, and frequency. Other elements of the system are the mainframe (top module), four counter/timer modules and a battery pack.

digit instrument. The effect is to make every range on the 5306A equivalent to two ranges on a typical four-digit meter. For example, in the 100 V range the resolution is 1 mV, so measurements can be made from millivolts to 100 V without changing ranges.

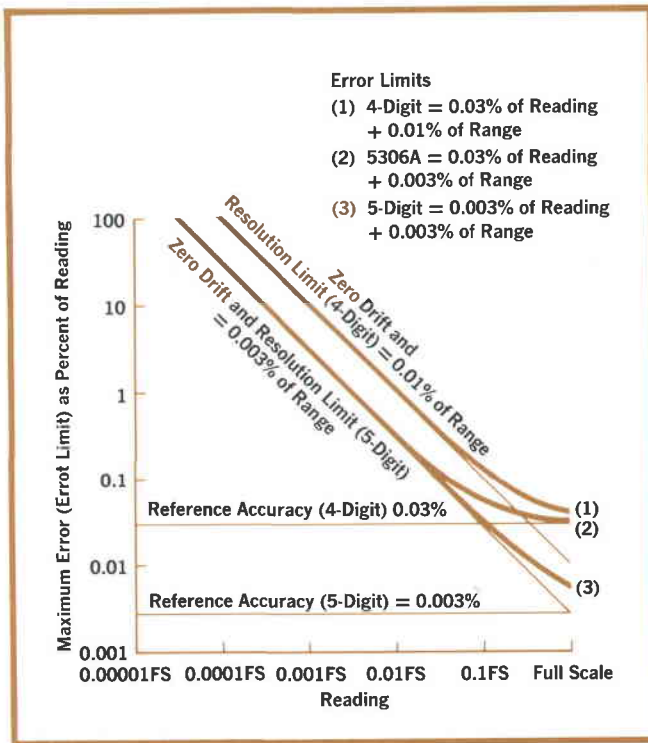

**Fig. 2.** Error limit versus reading for typical four-digit and five-digit voltmeters. Percent-of-range errors (i.e., zero drift and resolution) dominate the percent-of-reading errors or reference accuracy (caused by attenuator inaccuracy or reference drift). In Model 5306A an extra digit of resolution and an auto-zero system greatly reduce percent-of-range errors. Reference accuracy remains that of a four-digit instrument, but in other respects it is a full five-digit meter. Each range is equivalent to two ranges on the usual four-digit voltmeter.

When maximum resolution isn't needed and more than two measurements per second are desirable—for example, when displaying the results of a coarse adjustment—a FAST sample mode can be selected. Measurements are then ten times faster. Accuracy and resolution are both four digits.

In frequency measurements, the 5306A has the full six-digit accuracy and resolution built into the 5300A mainframe. Frequency range is 40 Hz to 10 MHz. The FAST sample mode can also be used for frequency measurements, again with one less digit of resolution.

### Design Philosophy

In designing a four-digit multimeter snap-on functional module for a six-digit counter mainframe, many questions had to be answered. The most obvious was what to do with the extra two digits in the mainframe.

One digit was easy to dispose of. The designers of the mainframe had foreseen that some future module might require a polarity indication in the display, and had made it easy to generate a minus

sign in place of the most significant digit. The 5306A uses the minus sign for dc voltage measurements.

The next most significant digit could have been used as an overrange digit, like the ½ digit of a 4½ digit multimeter. But this would have been wasteful because a full digit (that is, 0 through 9 instead of just 0 or 1) could be displayed in that position. It was suggested that the 5306A might be designed with five-digit accuracy. However, the extra cost wasn't compatible with the concept of the 5300 Measuring System as a low-cost laboratory and field instrument. The accuracy specification was finally fixed at 0.03%, or ±3 counts error in the fourth significant digit.

### Percent of Reading versus Percent of Range

Errors in a digital voltmeter fall into two categories: errors that must be specified as a percent of the actual reading and errors that must be specified as a percent of the range or full-scale reading. Attenuator coefficient uncertainty and reference drift cause percent of reading errors. Input amplifier zero drift causes percent of range errors.

The user, of course, is interested in the total error as a percent of his reading. Shown in Fig. 2 is a plot of reading versus percent error for a four-digit measurement. The limiting errors are the zero error and the resolution. If the resolution of the measurement could be extended and the zero error reduced, then while the reference accuracy (the accuracy of a full-scale reading) would remain the same, the dynamic range and the accuracy of smaller readings would be improved.

Improved resolution requires extra digits, of course, but for the 5306A an extra digit was already there. The decision, therefore, was to use a voltage-to-frequency converter with five-digit dynamic range and resolution, and to develop an auto-zero system for it that would reduce zero drift caused by time or temperature effects to a level compatible with a five-digit instrument.

The result is shown in Fig. 2, which compares the error limit for the 5306A with that of typical four-digit and five-digit voltmeters. The 5306A has four-digit accuracy as a percent of reading, but its percent of range errors are considerably reduced from the four-digit case. Thus the fifth digit is a full digit. The 5306A is a five-digit voltmeter with four-digit reference accuracy.

The design of the 5306A indicates that in some cases eliminating mechanical attenuators—that is, ranges—in favor of extra digital readouts may be justified from a cost/performance viewpoint.

### Voltage-to-Frequency Converter

Fig. 3 is a block diagram of the 5306A Multimeter/

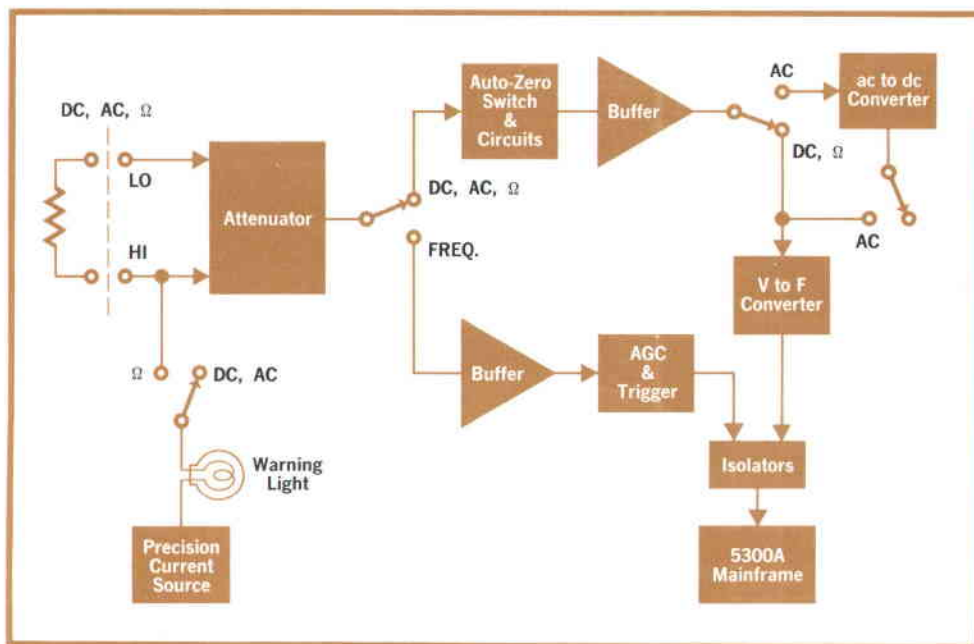

**Fig. 3.** 5306A is floating and isolated from the grounded mainframe. For frequency measurements, the input signal is shaped by the 5306A and measured by the mainframe with six-digit accuracy and resolution.

## Which Multimeter?

The Model 5306A Multimeter/Counter module now makes available multimeter capability in two apparently similar though actually different snap-together systems. The other system is the 3470 Measurement System, described in recent issues of the HP Journal.\*

The modules for one system do not work with the display sections of the other. This is because the 5300-series modules convert all input quantities into frequencies for conversion to a digital number by the 5300A Mainframe. The 3470 modules convert input quantities into a dc voltage for measurement by the 34740A (4½ digit) or 34750A (5½ digit) Display Sections.

With the wide range of capabilities that these two systems make available, chances are that most requirements can be filled exactly at reasonable cost. The decision of which multimeter to purchase will depend on what capabilities are presently owned, what capabilities are desired for present applications, and how the system may be expanded.

Present owners of 5300 Measuring Systems can add multimeter capability with the 5306A. Those not owning a 5300 or 3470 System currently should review the data sheets of both systems, considering their future needs as well as their present needs.

The 3470 Measurement System offers a selection of multimeter snap-on modules, a BCD-output in-between module, a battery pack, and two separate display units, one with 4½ digits and one with 5½. The 5300 Measuring System offers a 5-digit multimeter with frequency capability (Model 5306A), as well as a selection of frequency snap-ons, universal counter snap-ons, an analog-output in-between module, a battery pack, and a display module that includes BCD output.

Data sheets that give complete descriptions of both systems are available.

\*A. Gookin, "Compactness and Versatility in a New Plug-Together Digital Voltmeter," Hewlett-Packard Journal, August 1972.

R. Gardner, A. Dumont, S. Venzke, "A Greater Range of Capabilities for the Compact, Plug-on Digital Multimeter," Hewlett-Packard Journal, March 1973.

Counter. The voltage-to-frequency converter is essentially the same as that used in the 5326B/5327B Timer/Counter/DVM<sup>1</sup>. Fig. 4 is its circuit diagram. The converter is actually two essentially identical converters, one for positive input voltages and one for negative, sharing the same integrator. For clarity, only the positive converter is shown completely in Fig. 4.

Operation of the converter for a positive input voltage  $V_{in}$  is as follows.  $V_{in}$  goes to the integrator, and the integrator output is compared with a threshold voltage  $V_{th}$ . If the integrator output is more negative than  $V_{th}$ , then when the next clock pulse occurs (there's a clock pulse every five microseconds) the Q output of the flip-flop goes to its high state, routing the reference current  $I_R$ , which previously flowed through CR2, now through CR1 into the summing node of the integrator.

When the Q output of the flip-flop is in its high state, clock pulses are gated to the output. Thus the output signal consists of bursts of clock pulses at the frequency  $f_{in}$ , which is the counter time-base frequency of 10 MHz divided by 50, or 200 KHz. The ratio of the average converter output frequency,  $f_{out}$ , to the frequency  $f_{in}$  is the proportion of time that the Q output is in its high state. This duty cycle,  $\delta$ , is proportional to  $V_{in}$ , as the following equations show.

$$\int_0^T (i_1 + i_2 + i_c) dt = 0 \quad i_2 = -I_R \delta$$

$$i_1 = \frac{V_{in}}{R_1} \quad \int_0^T i_c dt \rightarrow 0$$

Therefore,  $V_{in} = I_R R_1 \delta = I_R R_1 f_{out} / f_{in}$ .



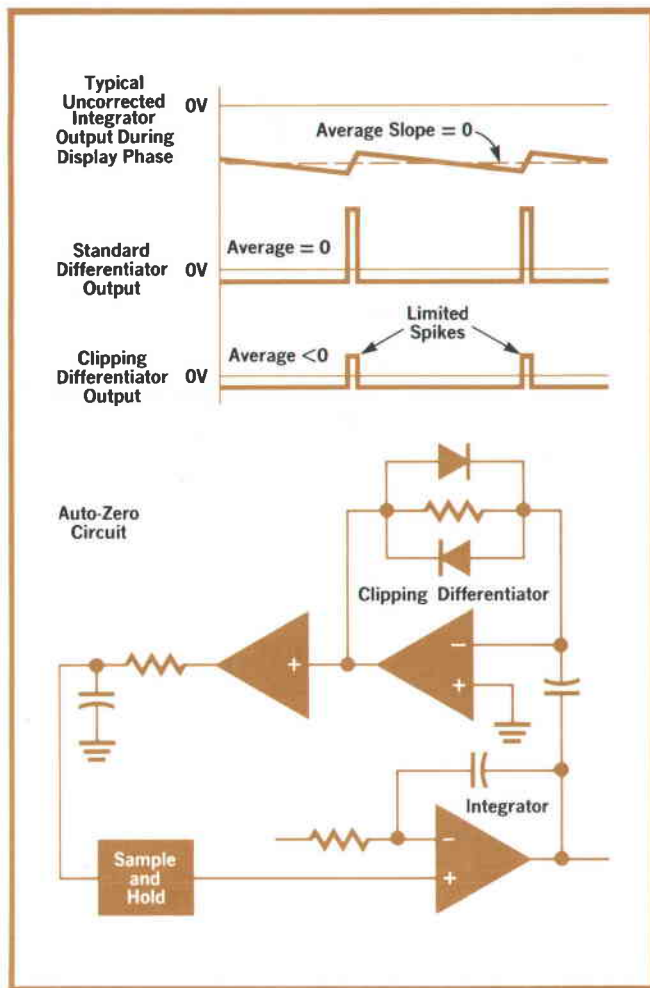

**Fig. 5.** Integrator output is differentiated to detect non-zero slope and derive the zero-correction voltage. Because the average output of a standard differentiator would be zero, a clipping differentiator is used.

### Floating Measurements and Isolated Output

Another problem in adapting a multimeter to the 5300A mainframe was how to provide floating measurements. The 5300A mainframe is firmly grounded, and even if future versions could be made floating, potential users of the 5306A who already have a mainframe would have to undertake some kind of retrofit to achieve a floating system.

The alternative chosen was to float just the 5306A portion of the instrument. It meant that a separate power supply had to be built into the 5306A module. Furthermore, to obtain the output data, couplers had to be included in the 5306A to isolate the output channel. The secondary benefit of having isolated ground-referenced BCD output as standard rather than as an expensive option helped justify the extra cost of the couplers.

### Ac Voltage Measurements

In the ac volts mode, the input signal is routed through the same input attenuator and buffer amplifier as in the dc volts mode. The signal is then half-wave rectified, and the resulting dc voltage applied to the V-to-F converter. This very common technique produces an average responding voltmeter, calibrated to read rms volts.

The ac-to-dc converter is simply a precision half-wave rectifier followed by a gain-filter stage. The gain is needed so a 10 V rms input will yield 10 V dc output. The filter reduces the amount of ripple voltage applied to the master integrator.

### Resistance Measurements

To make resistance measurements the precision current source used to measure negative voltages

## A Compact, Three-Digit Digital-to-Analog Converter Module

Model 5311A is a three-digit Digital-to-Analog Converter (DAC) designed for use with the 5300A Measurement System. It is packaged as an "in-between" module like the 5310A Battery Pack. The 5311A can be used with or without the battery pack and with any lower module. It converts the digital information from any three digits of the 5300A display to an analog output that can be recorded or used for other purposes. An expanded output for very small numbers can be obtained by selecting only the last two display digits for conversion.

Compared to separate digital-to-analog converters, Model 5311A is smaller, less expensive, and doesn't require a cable between it and the digital source; the required digital information is taken from the internal connector between module and mainframe.

The 5311A has three operating modes. In the normal mode, it works like other three-digit DACs: the analog output is directly proportional to the digital input. Thus an input

of 000 produces zero output, and 999 produces full-scale output.

In plus/minus mode, the 5311A produces half of full-scale output for a 000 input, and goes up or down to full scale or zero for +999 and -999, respectively. This mode is useful for recording dc voltages that cross through zero. The sign information is derived from the most significant digit of the display. With the 5306A Multimeter module, for example, this digit is a blank for a positive number and a minus sign for a negative number.

In the offset mode, the 5311A effectively adds 500 to the digital input before converting it. Thus 500 produces zero output, 000 produces half of full-scale, 999 produces a little less than half of full-scale, and 499 produces full-scale output. Having 999 and 000 adjacent at half of full scale is useful for recording signals that drift slowly in this region, because it eliminates the full-scale jumps that would otherwise occur. Such signals occur, for example, in measuring

temperature or time stabilities of crystal oscillators, which are often nominally at some frequency ending in 000.

### How It Works

Most DACs use precision resistors and transistor switches to generate currents related to the digital information. These currents are then summed to produce the analog output. The 5311A uses instead a pulse width modulation scheme. It generates a pulse train whose frequency and amplitude are constant but whose duty cycle is proportional to the digital information. This pulse train is low-pass filtered and the resulting dc signal is the analog output.

This method has some advantages and some disadvantages. Two disadvantages are that it takes many digital circuits and it is relatively slow. (The pulse frequency is low to give good resolution in the width modulation and the resultant has to be filtered well; as a result, the 5311A takes several milliseconds to slew full scale.) However, digital ICs are relatively inexpensive and the 5311A's speed is limited in any case by the scanning speed of the 5300A display (~2 ms) and the dead time between measurements (~40 ms).

The biggest advantage, in addition to low cost, is that the method is inherently monotonic and very linear, because it depends on digital logic and not on resistor matching.

As shown in the block diagram, the serial-to-parallel converter extracts the selected three digits of information from the 5300A's scanned display. Selection is by means of the pushbutton switches on the front panel.

The width-modulated pulse is first visible at the output

of the cycle flip-flop. The Q output of the cycle flip-flop is set high by the overflow from the three-decade counter and is cleared by the output of the 12-bit comparator. Thus it goes high at a count of 000 and low at some later time when the count in the three-decade counter equals the digital input.

The oscillator frequency isn't important because the duty cycle is independent of it. However, some short-term stability is required to avoid excessive jitter in the pulse width. Therefore a simple one-transistor LC oscillator is used.

The  $\pm$  flip-flop disables the comparator output every other cycle in the  $\pm$  mode so the output of the cycle flip-flop is a square wave for a 000 digital input. Then either Q or  $\bar{Q}$  is selected in the combinational logic depending on the sign information in the most significant digit.

For the offset mode, a signal that tells whether the counter state is  $<500$  and another signal that tells whether the three-digit number is  $<500$  are ANDed with the cycle flip-flop output to perform the adding function. A BCD adder could have been used, and the addition performed on the BCD data, but this would have been more expensive.

The output of the combinational logic drives a saturating switch, which in turn drives a CMOS gate used as a series shunt switch. The gate switches the input of the low-pass filter between ground and a 10 V reference supply. The output of the three-pole low-pass filter is a dc voltage ranging from zero to 10 V. This is divided to give three ranges for different potentiometric (voltage sensing) recorders or converted to current for a galvanometric (current sensing) recorder.

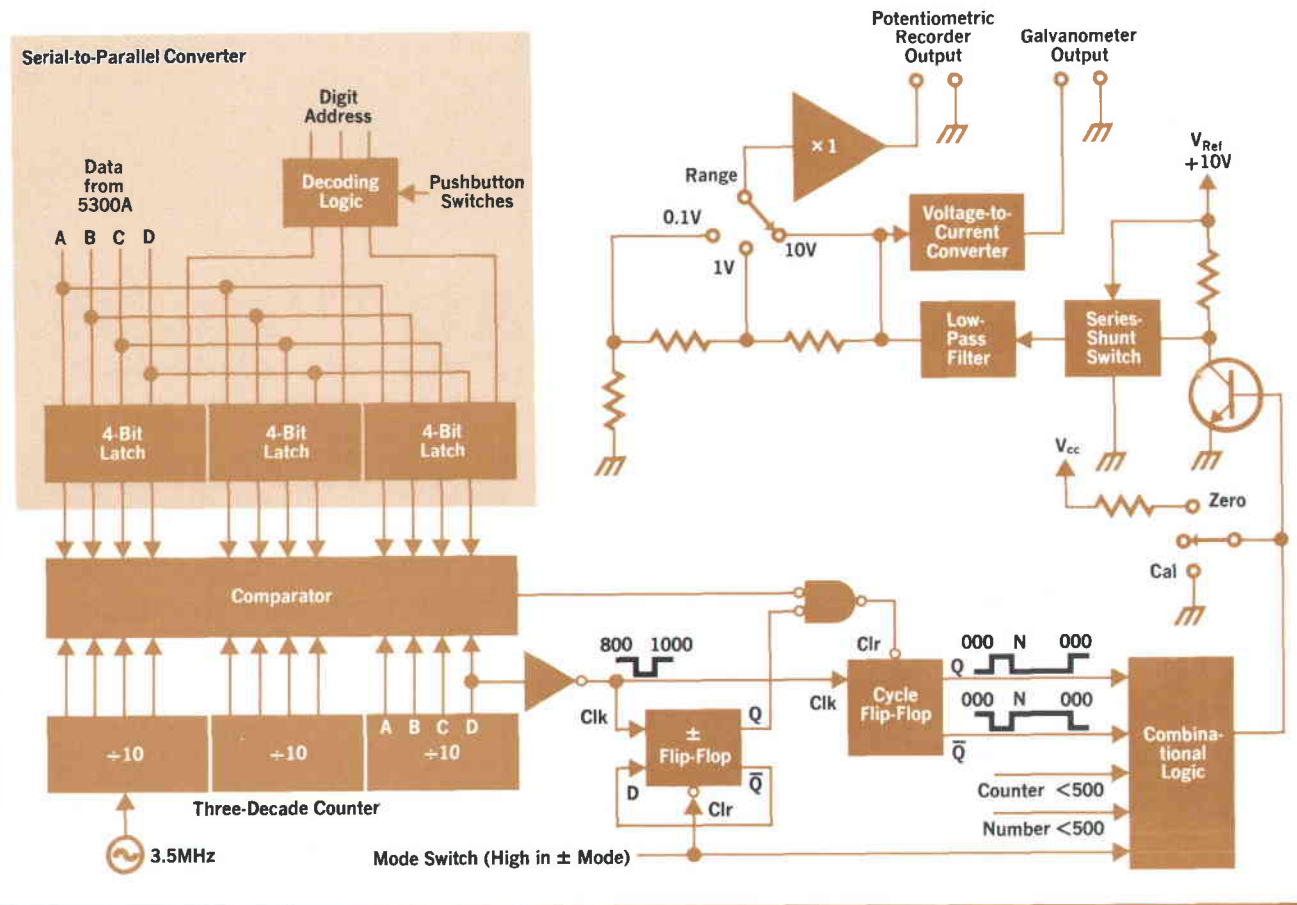

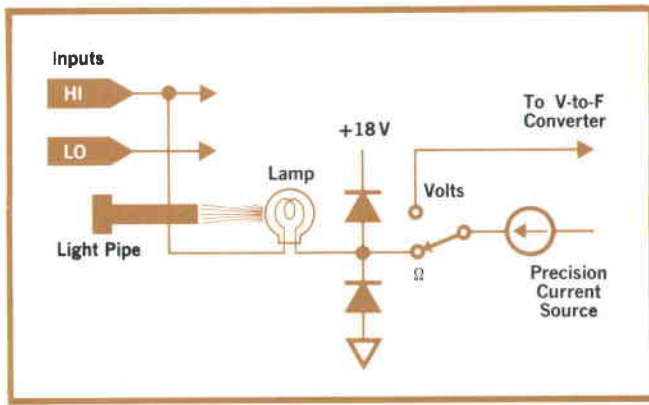

**Fig. 6.** Lamp acts as a variable resistance to protect the precision current source from damage and warn the user in case a high voltage is applied to the input during a resistance measurement.

in the V-to-F converter is diverted to the input terminals. It passes through the unknown resistor producing a positive voltage proportional to the resistance. This is then measured by the other precision current source working with the V-to-F converter. This technique saves the cost of a separate current source for resistance measurements.

For protection against external voltages the 5306A uses an interesting scheme. The precision current flows through an incandescent lamp before arriving at the input terminals (see Fig. 6). When a resistor is present at the input the low value of reference current (1 mA or less) fails to light the lamp and thus the lamp resistance stays low and doesn't disturb the measurement. Should a large voltage appear by mistake across the input terminals, current

rushes through the lamp, heating it and increasing its resistance until the current is effectively limited. If a high enough voltage is applied the lamp will act like a fuse and burn out. The protection scheme is effective for input voltages as high as 240 V.

As a secondary benefit of the lamp system, the lamp's glow is visible through a red insert on the front panel, thus warning the user that a dangerous voltage is present.

### Frequency Measurements

Although a few voltmeters now have frequency as a standard function, these voltmeters generally convert each incoming count into a unit charge and inject this charge into an integrating circuit. They then measure the resulting voltage using a voltmeter technique and display the answer with appropriate frequency units. The resulting frequency measurement has no more accuracy than the accuracy of the voltmeter, which at best is usually 0.01%.

A dedicated frequency meter, on the other hand, counts each pulse using as its standard a crystal oscillator, which is usually accurate to parts in  $10^6$  or 0.0001%. This is the case with the frequency-counting 10-MHz 5300A mainframe. Therefore, to count frequency, the 5306A completely bypasses the voltmeter portions of the circuit and goes directly to the counting circuits of the mainframe, thereby achieving an accuracy commensurate with a dedicated counting instrument (Fig. 7).

To maximize user convenience the frequency counter input is common with the volts/ohms input. This arrangement, for instance, allows the user to

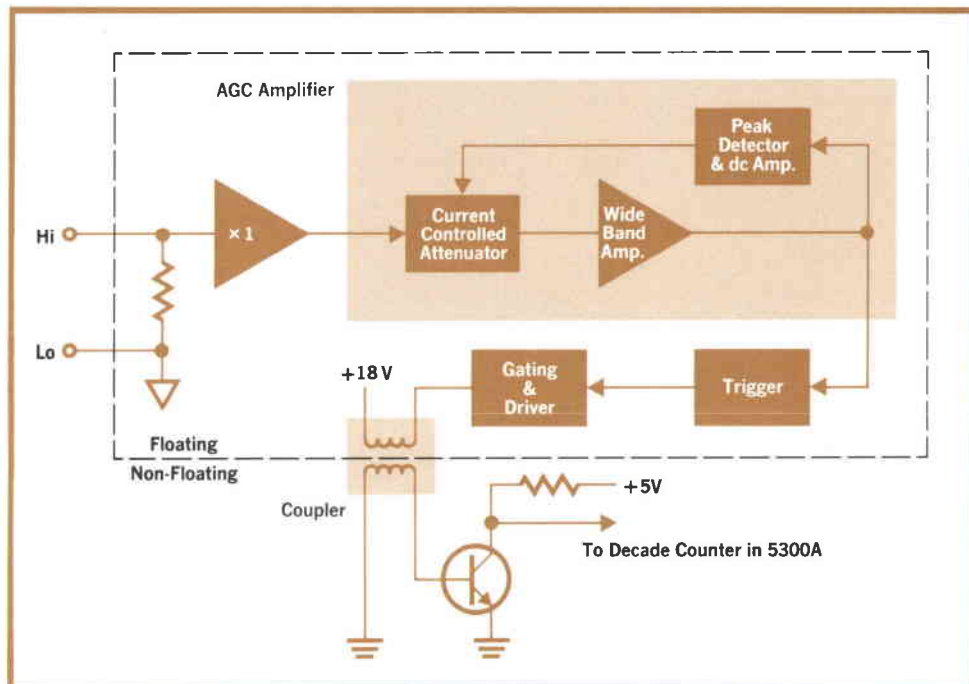

**Fig. 7.** Frequency input is common with volts/ohms input. Floating input allows frequency measurements in the presence of large common-mode voltages. Signal conditioning is done automatically rather than by front-panel controls.

measure both the amplitude and the frequency of a signal with no change of test leads or switching of connectors, merely the push of a button. Also, since the frequency input and amplifier are fully floating, the 5306A provides measurement capability in the presence of large common-mode voltages. This useful feature is rarely found in general-purpose counters.

Good frequency counters usually give the user input signal conditioning controls so that noise rejection may be optimized. To eliminate user adjustments and yet provide reliable operation over a wide range of input signals, this optimization is

done automatically in the 5306A. Noise rejection is generally provided by the deadband, or hysteresis, of the trigger circuit used to convert the input into a pulse train compatible with the digital counting logic. No noise signal can cause miscounting if its peak amplitude is less than the deadband of the trigger (the signal, of course, must be larger than the deadband). For optimum noise rejection we would like the deadband smaller than the signal but larger than the noise.

In general, there are two ways to adjust the noise immunity: vary the actual hysteresis of the trigger, or vary the amplitude of the signal fed to the trigger. The latter method is used in the 5306A and is accomplished with an automatic gain control (AGC) amplifier. The output of the AGC amplifier is approximately constant for input voltages between 100mV rms and 10V rms, and drives a trigger circuit whose deadband is about 30% of the peak-to-peak output signal swing. Over that range of input voltages, the noise rejection varies from about 60mV to about 6V, adequate for most applications.

Most ac-coupled frequency counters need offset controls or switches when they are used to count pulses or other low-duty-cycle signals. The 5306A can accept either positive pulses or 50% duty cycle signals like sine or square waves. Ordinarily, this would preclude the counting of negative pulses. However, the floating input will often allow the user to reverse the input connector, and thus reverse the apparent polarity.

The 5300A mainframe will accept count rates up to 10MHz. While it was easy to design an AGC amplifier and trigger for this range, it proved difficult to transfer the high-frequency signal from the floating input to the nonfloating counter. The solution to this problem is a coupling scheme which uses two closely spaced molded RF chokes as a pulse transformer. The speed was improved by using very low-inductance "windings" and driving the primary with high currents.

#### Acknowledgments

We would like to thank Ian Band, who provided technical advice, moral support, and overall guidance for the project. We would also like to thank Bruce Corya for the mechanical design, Steve Combs for the ac-to-dc converter design, and Larry Forman, Don Larke, Jim Feagin, and Rey Canio for successfully bringing the projects into production. 📧

#### References

1. K. J. Jochim and R. Schmidhauser, "Timer/Counter/DVM: A Synergistic Prodigy?", Hewlett-Packard Journal, April 1970.
2. R. M. Bracewell, "The Fourier Transform and Its Applications," McGraw-Hill, 1965.

## APPENDIX

### 5306A Noise Rejection Characteristics

The normal mode noise rejection characteristic of the 5306A voltmeter is similar to that of an integrating voltmeter. However, the integrating characteristic comes not from the RC integrator shown in Fig. 4, but from the frequency counter in the 5300A mainframe. The 5306A merely converts the incoming voltage  $V(t)$ , into a directly proportional frequency  $f(t)$ . The number displayed by the 5300A mainframe, i.e., the measured voltage, is the integral of the frequency generated by the V-to-F converter (within the specified accuracy of the 5306A).

$$N(t_0) = \int_{t_0}^{t_0 + G} \frac{1}{G} V(t) dt \quad (1)$$

where  $V(t)$  is the instantaneous input voltage,  $t_0$  is the time the measurement starts,  $G$  is the counter gate time, and  $N(t)$  is the displayed voltage for a measurement beginning at time  $t$ .

To determine the normal mode rejection characteristic of the system, we would like to find  $F(s)$  in the equation

$$N(s) = \frac{1}{G} V(s) F(s) \quad (2)$$

where  $V(s)$  is the Fourier transform of  $V(t)$ ,  $N(s)$  is the Fourier transform of  $N(t)$ , and  $1/F(s)$  is, by definition, the rejection characteristic of the system.

We begin by noting that the gating of a counter is equivalent to multiplying the measured function  $V(t)$  by 1 during the gate time and zero at all other times, i.e., multiplying by the rectangle function  $r[(t-t_0)/G-1/2]$ , where

$$r(t) = \begin{cases} 0 & |t| < 1/2 \\ 1 & |t| > 1/2 \end{cases}$$

Rewriting equation 1, we have

$$N(t_0) = \frac{1}{G} \int_{-\infty}^{\infty} V(t) r[(t-t_0)/G-1/2] dt$$

which is in the form of a convolution of  $V(t)$  with  $r_1(t) = r(-1/2 - t/G)$ . Therefore (ref. 2, p. 110)

$$N(s) = V(s) R_1(s)$$

where  $R_1(s)$  is the Fourier transform of  $r_1(t)$ . Thus  $R_1(s)$  is our  $F(s)$  in equation 2.

To find  $R_1(s)$  we start with (ref. 2, p. 128)

$$R(s) = \sin \pi s / \pi s.$$

By the similarity theorem (ref. 2, p. 122),

$$r(-t/G) \rightarrow |-G| \frac{\sin(-\pi Gs)}{-\pi Gs} = \frac{\sin \pi Gs}{\pi s}$$

and by the shift theorem (ref. 2, p. 122),

$$r\left[-\frac{1}{G}(t - G/2)\right] = r(-1/2 - t/G) = r_1(t) \rightarrow \frac{\sin \pi Gs}{\pi s} e^{i\pi Gs}.$$

$$\text{Thus } \left| F(s) \right| = \left| \frac{\sin \pi Gs}{\pi Gs} \right|$$

When inverted, this yields the familiar cusp-shaped rejection characteristic of the integrating voltmeter.

## SPECIFICATIONS

### HP 5306A Multimeter Counter dc Voltage

RANGES:  $\pm 10V$ ,  $\pm 100V$ ,  $\pm 1000V$

Range	Accuracy*	Sensitivity**
10V	$\pm$ (0.3% of reading + 0.03% of range)	100 $\mu V$
100V	$\pm$ (0.3% of reading + 0.03% of range)	1 mV
1000V	$\pm$ (0.7% of reading + 0.3% of range)	10 mV

**TEMPERATURE COEFFICIENT:**  
 $\pm$  (0.02% of reading/ $^{\circ}C$  + 0.002% of range/ $^{\circ}C$ )

**SAMPLE TIMES:** Normal, 0.5 sec; Fast, 0.05 sec.

**INPUT TERMINALS:** Floating pair

**INPUT RESISTANCE:** 10 M $\Omega$ , all ranges

**ZERO ADJUST:** Automatic

**EFFECTIVE COMMON MODE REJECTION** (1 k $\Omega$  imbalance):

dc:  $>$ 80 dB

50 Hz or 60 Hz  $\pm$  1%:  $>$ 80 dB

**NORMAL MODE REJECTION:** 50 Hz or 60 Hz  $\pm$  1%:  $>$ 50 dB

**MAXIMUM INPUT:**

HIGH TO LOW: 1100V dc all ranges

LOW TO GUARD:  $\pm$ 200V dc or peak ac

GUARD TO GROUND:  $\pm$ 500V dc or 240V rms at 50 or 60 Hz

### ac Voltage

RANGES: 10V, 100V, 1000V

Range	Frequency	Accuracy*
10V	40 Hz to 10 kHz	$\pm$ (0.8% of reading + 0.2% of range)
	10 kHz to 100 kHz	$\pm$ (0.8% of reading + 1.0% of range)
100V	40 Hz to 500 Hz	$\pm$ (1.5% of reading + 0.5% of range)
1000V	40 Hz to 500 Hz	$\pm$ (1.5% of reading + 0.5% of range)

\*60 days, 23 $^{\circ}C$   $\pm$  5 $^{\circ}C$ ,  $\leq$ 80% RH \*\*Sensitivity for normal sample time.

### TEMPERATURE COEFFICIENT:

10V AND 100V RANGE:  $\pm$  (0.03% of range/ $^{\circ}C$ )

1000V RANGE:  $\pm$  (5% of reading/ $^{\circ}C$ )

**INPUT IMPEDANCE:** 10 M $\Omega$   $<$ 75 pF maximum

**COUPLING:** ac; max dc blocking of  $\pm$ 1000V

### MAXIMUM INPUT VOLTAGE:

HIGH TO LOW: 1000V except on 10V range; on 10V range, 5 x 10 $^4$  VHz limit with minimum protection of 50V, max 1000V

LOW TO GUARD:  $\pm$ 200V dc or peak ac

GUARD TO GROUND:  $\pm$ 500V dc or 230V at 60 Hz

**EFFECTIVE COMMON MODE REJECTION** (1 k $\Omega$  imbalance):

dc:  $>$ 80 dB

50 Hz or 60 Hz  $\pm$  0.1%:  $>$ 50 dB

### Ohms

RANGES: 10 k $\Omega$ , 100 k $\Omega$ , 10 M $\Omega$

Range	Accuracy*	Sensitivity**
10 k $\Omega$	$\pm$ (0.5% of reading + 0.03% of range)	10
100 k $\Omega$	$\pm$ (0.5% of reading + 0.03% of range)	10
10 M $\Omega$	$\pm$ (0.75% of reading + 0.03% of range)	1000

**TEMPERATURE COEFFICIENT:**  $\pm$  (0.002% of range/ $^{\circ}C$ )

**CURRENT THROUGH UNKNOWN:** 1 mA on 10 k $\Omega$  range; 100  $\mu A$  on 100 k $\Omega$  range; 1  $\mu A$  on 10 M $\Omega$  range

### OVERLOAD PROTECTION:

10 k $\Omega$  RANGE: 240V rms for 1 min. 140V rms continuous (warning lamp indicates over-voltage condition)

100 k $\Omega$ , 10 M $\Omega$  RANGES: 240V rms continuous

### Frequency

RANGE: 40 Hz to 10 MHz

**SENSITIVITY (MIN):**

40 Hz TO 1 MHz: 50 mV rms sine wave

1 MHz TO 10 MHz: 125 mV rms sine wave

**IMPEDANCE:** 1 M $\Omega$  on 10V range, 10 M $\Omega$  on other ranges

**COUPLING:** ac; max dc blocking,  $\pm$ 1000V

**TRIGGERING LEVEL:** Positive with respect to average value of input signal, automatically adjusted to 40% (nominal) of positive peak level of input.

**OVERLOAD PROTECTION:** 1000V rms except 10V range. On 10V range 240V rms limit from 40 Hz to 400 kHz, 10 $^4$  VHz limit from 400 kHz to 10 MHz.

### GATE TIMES:

NORMAL: 1 sec (1 Hz resolution)

FAST: 1 sec (10 Hz resolution)

**ACCURACY:**  $\pm$ 1 count  $\pm$  time base accuracy

**PRICE IN U.S.A.:** \$450.00

### HP 5311A Digital-to-Analog Converter

#### OUTPUT SELECTION:

Manual pushbuttons to select any three consecutive digits or the last two digits of the 5300A Mainframe display.

#### OUTPUT RANGES:

Potentiometric recorder output: 0.1V, 1.0V, or 10V full scale into  $>$ 20 k $\Omega$ ; Dual banana plugs

Galvanometer Recorder Output: 1 mA full scale into  $\leq$ 1.5 k $\Omega$ ; Phone jack

#### ACCURACY:

$\pm$ 0.25% of range  $\pm$ 50  $\mu V/^{\circ}C$  on potentiometric output,  $\pm$ 20 nA/ $^{\circ}C$  on galvanometer output after calibration for appropriate range.

**CALIBRATION:** zero and full scale calibration switch and adjustments on rear panel.

**OPERATING MODES:** three modes selectable by switch on rear panel.

MODE/INPUT	OUTPUT		
	0 to 50% of Full Scale	50% of Full Scale	50% to 100% of Full Scale
Normal	0 to 499	500	501 to 999
Plus/Minus	-999 to -001	000	001 to 999
Offset	500 to 999	000	001 to 499

**TRANSFER TIME:**  $<$ 5 ms

**OPERATING TEMPERATURE:** 0 $^{\circ}$  to 50 $^{\circ}C$

**PRICE IN U.S.A.:** \$295.00

**MANUFACTURING DIVISION:** Santa Clara Division  
5301 Stevens Creek Boulevard  
Santa Clara, California 95050



### James F. Horner (RIGHT)

Jim Horner received his BSEE and MSEE degrees from Stanford University in 1966 and 1968, then spent two years in the U.S. Army before joining HP in 1970. After designing several circuits for the 5326/27 Counters, he took on the 5306A Multimeter/Counter as project leader. As for hobbies and interests, Jim says he has "many . . . which take up about 10% of my available non-work time. The other 90% of this time is spent in the enjoyable activity of helping my wife raise our two daughters."

### Lewis W. Masters (LEFT)

Lew Masters began his career as a mechanical engineer, but only worked in that field for a year before switching to electrical engineering. He received his BS degree in mechanical engineering from the University of Maryland in 1966, then attended the University of California at Santa Barbara and received his MS in electrical engineering in 1969. At HP since 1970, Lew has been involved with the 5300 Measuring System, designing all or part of three functional modules, including the 5306A Multimeter/Counter. Lew also designs and builds his own hi-fi equipment and enjoys making fine furniture for his home.

### P. Thomas Mingle (CENTER)

Tom Mingle, designer of the 5311A Digital-to-Analog Converter, received his BS degree in electrical engineering from Oregon State University in 1968 and his MSEE degree from Stanford University in 1969. His HP career dates from the summer of 1968 and includes circuit design for the 5326/27 Counters and the 5300A Mainframe, and design of two functional modules for the 5300 Measuring System in addition to the 5311A. In his spare time Tom serves as a consultant for a small laser company. His major non-electronic interests are bridge, softball, and automobiles (he edits the newsletter of the Mazda Owners Club of America).

# Laser/Calculator System Improves Encoder Plate Measurements

*This in-house system is a good example of what the right combination of instruments and calculator can do for measurements. Developed for acceptance testing of the optical position-encoder plates used in HP moving-head disc drives, its speed and accuracy have helped improve yields from the original 20% to the present 90%.*

by Glenn O. Herreman

**I**N AN HP 7900-SERIES Moving Head Disc Drive, the position feedback needed by the servo system for rapid, accurate positioning of the flying heads is provided by an optical position encoder<sup>1</sup>. The encoder consists of a glass encoder plate, a reticle, a light source and a pair of photodetectors. Encoder accuracy is crucial to the performance of the disc drive, so every encoder plate must be checked for accuracy before being installed.

The encoder plate is a glass scale that has a series of 0.005 inch windows separated by 0.005 inch spaces (Fig. 1). There are 253 windows and 506 line edges. The location of every line edge relative to the centerline average must be accurate within  $\pm 130$  microinches, and the measuring system that checks this accuracy must be accurate within  $\pm 10$  microinches.

The system being used to measure the encoder plates is shown in Fig. 2. It consists of a large tool-

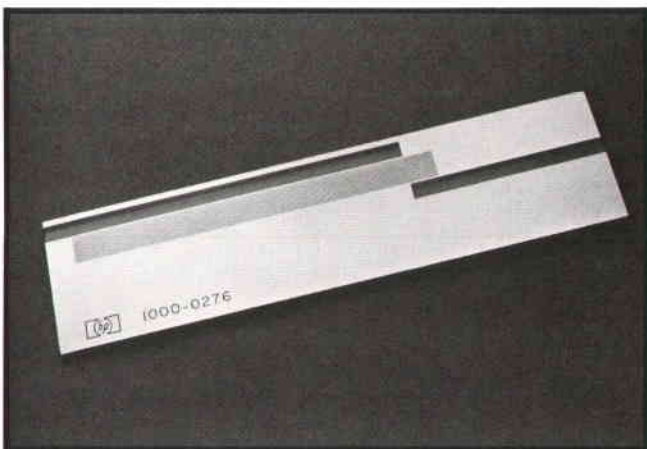

**Fig. 1.** Encoder plate has 506 line edges that must be accurate within  $\pm 130 \mu\text{in}$ . The measuring system that checks the plates must be accurate within  $\pm 10 \mu\text{in}$ .

maker's microscope, a photoelectric microscope tube, an air-motor drive, an HP 5526A Laser Interferometer, an HP 9820A Calculator, and an HP 9862A Plotter. An HP 1205A Oscilloscope monitors the microscope output. Fig. 3 is a diagram of the system.

The plate to be measured is mounted on the precision microscope stage. The air motor pushes the precision stage at a constant speed of 0.007 inch per second (checked with the velocity mode of the laser interferometer). The encoder plate passes under the photoelectric microscope and as each edge passes the photodetector a pulse is sent to the laser display. The laser displays the position at that point and transfers the number to the 9820A Calculator, which compares the measured position with the corresponding nominal position. The deviation from nominal is then plotted on the 9862A Plotter.

To determine a reference zero, or centerline average, the calculator is programmed to count each line and take the average of the deviations of lines #222 through #261. After the last line is inspected the calculator instructs the plotter to go to this centerline average and draw a line back to the beginning and then, starting from this reference line, to draw the upper and lower limit lines. The final instruction from the calculator is to have the plotter write the average relative to the starting zero and the maximum and minimum points relative to the centerline average.

Fig. 4 shows typical plots for acceptable and unacceptable plates. Any point falling beyond the limit lines signals a reject plate.

The entire operation takes about 6½ minutes per plate and the plot shows at a glance the magnitude of window-opening deviations as well as the pattern geometry. HP can easily communicate with the supplier simply by sending him the plots so he can see

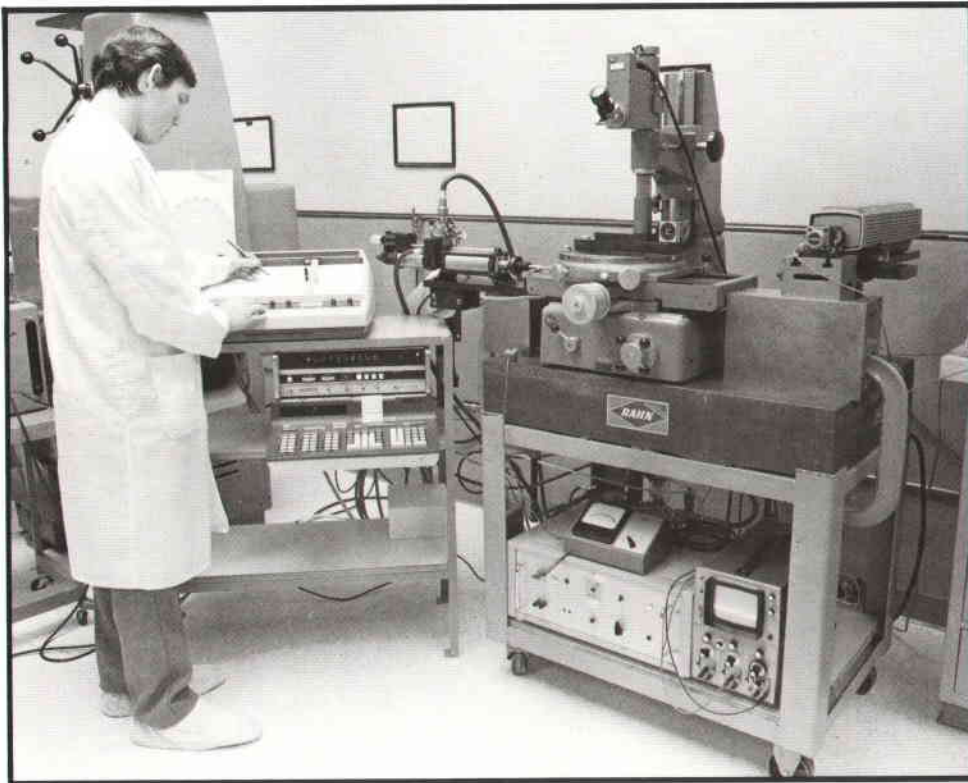

**Fig. 2.** Measuring system consists of toolmaker's microscope, photoelectric microscope tube, air motor drive, laser interferometer, calculator and plotter. The oscilloscope is used to monitor the photoelectric microscope output.

the problem and make corrections if necessary.

Using this measuring system and working with the supplier has improved encoder-plate yield from approximately 20% accept to approximately 90% accept.

### How the System Evolved

Originally, encoder plates were checked by a microscope and micrometer measurement. Because of accuracy and reliability problems the laser interferometer soon replaced the micrometer head for positional readout. The laser interferometer revealed that an operator couldn't reliably and accurately set the microscope to a line edge, so the photoelectric microscope was added. Now a line edge could be set by nulling a center-zero meter.

At this point the operator manually positioned the stage with a large micrometer head until he nulled the meter. The laser display was then manually printed with a remote switch. It took about 2½ hours to manually inspect each line edge and more time to check the printed tapes.

To speed up the system, an air motor was added to replace the micrometer head. This made it possible to move at a constant rate of speed and automatically print each position, but there still was the tedious job of interpreting the printed tapes. The tapes only gave numbers, which weren't easily translated into a picture of what was happening. We wanted to know whether the windows were wide or narrow and we also wanted to know the shape of the curve—a falling curve indicates a short

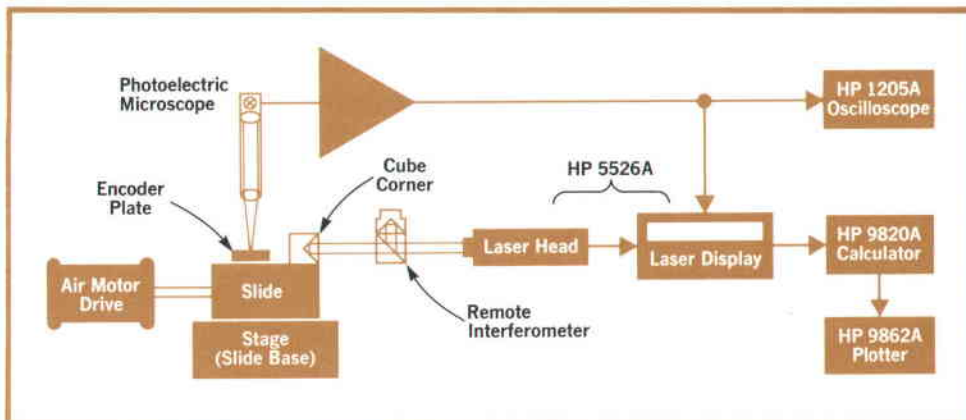

**Fig. 3.** Photoelectric microscope detects line edge and signals interferometer to measure location. Calculator compares actual and nominal locations and plots deviation.

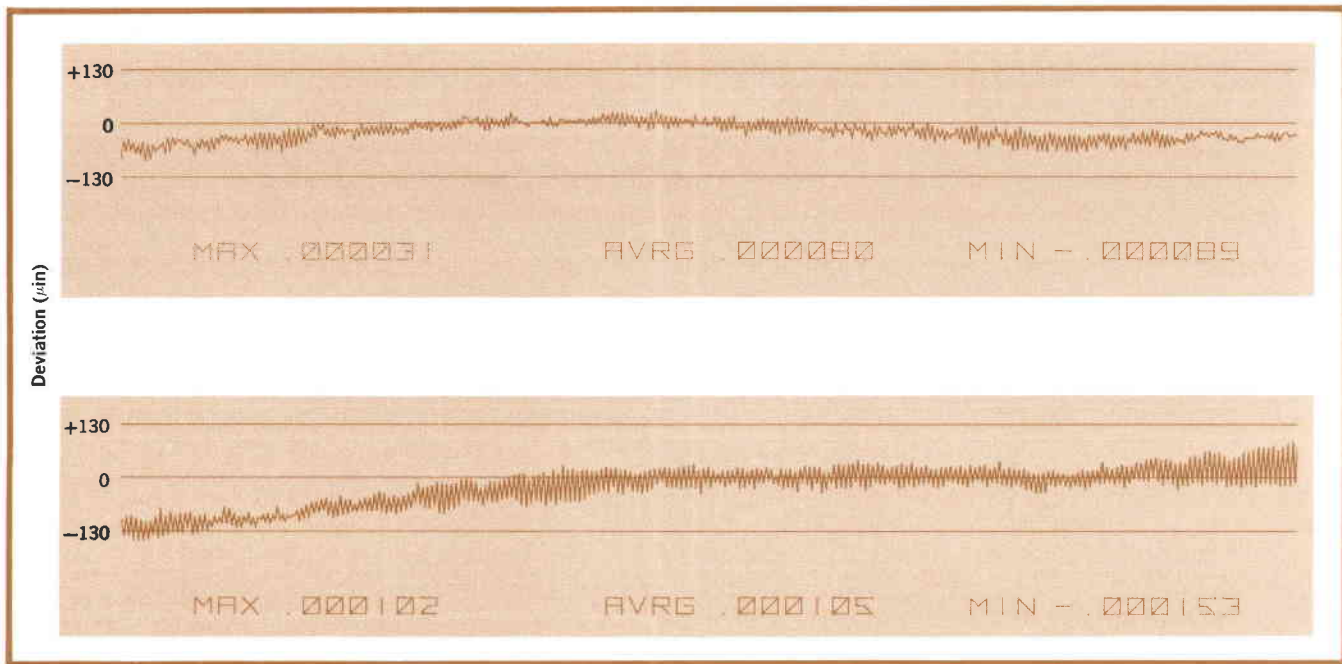

**Fig. 4.** Typical plots for acceptable plate (top) and reject plate. Rising curve indicates long pattern and vice versa.

pattern and, conversely, a rising curve indicates a long pattern. Therefore, the final stage of the evolution was to interface the 9820A Calculator and the 9862A Plotter to the laser interferometer.

Future plans call for replacing the toolmaker's microscope with an air bearing stage. The system would then be dedicated to encoder plates and semiconductor masks.

#### Acknowledgments

Ed Duzowski helped design the system. Dave Handbury wrote the Calculator/Plotter program, and Tom Logue has contributed several refinements to it.

#### Reference

1. J. E. Herlinger and W. J. Lloyd, "Inside the 7900 Disc Drive," Hewlett-Packard Journal, May 1972.



#### Glenn O. Herreman

When Glenn Herreman joined HP as a tool engineer in 1951, he already had nine years experience in that field. With seven more years under his belt, he became a quality assurance engineer in 1958, and two years later, gage lab supervisor. Since 1962 he's been manager of dimensional metrology. A member of the American Society for Quality Control, Glenn has taught quality control at a community college and has authored several articles and papers on various aspects of metrology. In his spare time he's worked with many local youth groups, he's an amateur photographer, and he enjoys auto/trailer travel and fishing.

### Calculator with Metrology Programs Now a Laser Option

The Model 9820A Calculator and its peripherals are now available as options to the Model 5526A Laser Measurement System along with a number of specially developed metrology applications programs. In addition to saving a significant amount of data reduction time in such applications as surface plate certification and machine tool and measuring machine calibration, the ability to directly interface the Laser Display to the Calculator makes possible Laser/Calculator installations on multi-axis coordinate measuring machines for readout and/or control.

# Instrument Basics Without Pain

*Engineers and non-engineers in science and technology have one thing in common: they need to understand electronic instruments. Hewlett-Packard's Clyde Coombs has assembled a book that answers the need.*

**A**S THE ART OF MEASUREMENT HAS ADVANCED, the technology of making measurements has increasingly relied on electrical and electronic methods. This comes about for two reasons. First, once information is transformed into electrical form, it can readily be processed in ways that will meet the needs of a great variety of individual situations. Second, most phenomena, such as temperature, speed, distance, light, sound and pressure can be readily transformed into electrical indications for processing and interpretation."

The quote is from Frederick E. Terman's "Measurement and the Growth of Knowledge," Chapter 1 of the new "Basic Electronic Instrument Handbook" which has been assembled by Hewlett-Packard's Clyde F. Coombs, Jr., and published by McGraw-Hill.

Although the book will be immediately useful to the electronic engineer as a quick refresher on any instrument he has not recently used, it will be invaluable to non-engineers in science and technology to help match needs with instrument capabilities. Indeed its greatest usefulness to engineers may be in improving the quality of their communication with non-engineering colleagues!

With no sacrifice of precision or accuracy (the distinction between them being drawn by NBS spokesman Thomas L. Zapf in Chapter 4), the book dispenses with mathematical exposition beyond algebra, and concentrates on the principles upon which instruments operate and the relations that exist between them and the subjects they measure. With these understood, instrument use becomes a part of the solution rather than a part of the problem before the technologist.

Not that the authors expect to make these matters plain to those with no knowledge of electronic fundamentals: the fundamentals are there in the

text. For example, in their chapter on impedance considerations, K. D. Baker and D. A. Burt of Utah State University inform the reader, with a casualness that makes the learning easy, that impedance ( $Z$ ) is the ratio of the voltage ( $V$ ) across a circuit to the current ( $I$ ) flowing in the circuit. Only two pages later the reader has learned that  $|Z| = \sqrt{X^2 + R^2}$  and that if impedance is stated in polar form ( $|Z|\angle\phi$ ), the inverse operation to resistive and reactive components is:

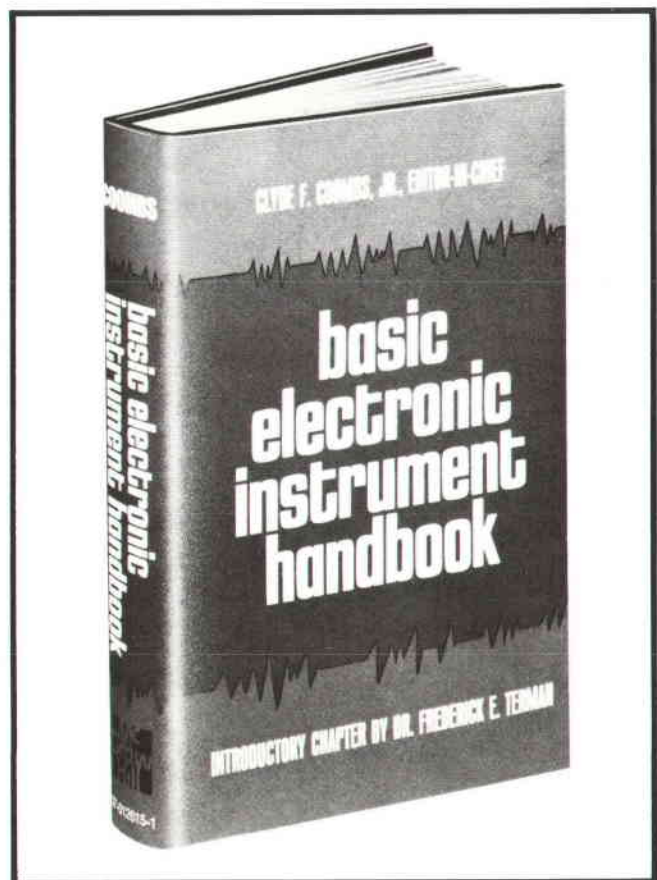

$$R = |Z| \cos \phi$$

$$X = |Z| \sin \phi,$$

where  $\phi$  is the angle whose tangent is  $X/R$ .

Similarly, Eugene L. Mleczo, telling how problems may be solved by instruments in systems, takes the time to make some nice distinctions between the analog domain and the digital domain:

"... an analog value cannot be measured exactly, but only with some degree of precision, because it is a continuous function. On the other hand, a digital value is discrete or exact, even though it may be an inexact representation of an analog value of interest."

Of course the 836-page text does not remain at this fundamental level. Most of it is on the specifics of instrument capabilities, so the reader can choose the measuring array that will best serve his needs, present and future, and use it in such a way that he can rely on the validity of his findings. How many times have readings been taken as Total Truth, simply because the instrument-maker is of fine repute, when there may have been impedance mismatches, pulse rise-times too fast, or common-mode interference in the set-up? Coombs will have made a lasting contribution, not only to the peace of mind of engineers who aid researchers, but perhaps to science itself if his text prevents many such errors. All these and many other sources of potential error are covered by one or another of the twenty-three authorities Coombs has brought into collaboration.

The National Bureau of Standards' Wilbert F. Snyder contributes an introduction to the standards upon which all measurements, electrical and otherwise, are based. Prof. Edwin C. Jones of Iowa State early in the book establishes what one can expect of transducers. His colleague, Dr. Donald H. Schus-

ter, makes known the principles of signal generation. The mysteries are removed from the art of measuring current and voltage by HP's Larry Carlson and Lee Thompson (who design meters for the purpose) and by Jack Day, once of Tektronix, now development officer for the Oregon Museum of Science and Industry. Electronic counters, frequency-standard, and timekeeping instruments are made clear by HP's Marv Willrodt, who has made a successful life's work of knowing, and answering, just about every question ever asked about these devices.

Atherton Noyes, variously of Harvard's Cruft Laboratory, General Radio Company, Aircraft Radio Corporation, and now of his own consultant firm, tells how and why frequency synthesizers of the various types do what they do. Recorders of the several types are dealt with; X-Y recorders are explained by no one less than a principal inventor in the field, Francis L. Moseley. Microwave instruments are included, authors being HP Microwave Division project manager Harley L. Halverson and the distinguished consultant and author, Gershon J. Wheeler.

"This is a book about electronic instruments... not a 'measurements' book," editor Coombs says in his Preface. "... specific measurements are discussed only as examples of applications of the instruments. It is felt that with a clear understanding of the instruments themselves and how they work together, the reader is in the best position to define his own solution to a measurement problem."

"Basic Electronic Instrument Handbook" is the title; Clyde F. Coombs, Jr. is editor-in-chief. The publisher is McGraw-Hill Book Company, New York, and the price is \$28.50. — Ross Snyder

Hewlett-Packard Company, 1501 Page Mill  
Road, Palo Alto, California 94304

## HEWLETT-PACKARD JOURNAL

JUNE 1973 Volume 24 • Number 10

Technical Information from the Laboratories of  
Hewlett-Packard Company

Hewlett-Packard S.A., CH-1217 Meyrin 2  
Geneva, Switzerland  
Yokogawa-Hewlett-Packard Ltd., Shibuya-Ku  
Tokyo 151 Japan

Editorial Director • Howard L. Roberts  
Managing Editor • Richard P. Dolan  
Contributing Editors • Ross H. Snyder,  
Laurence D. Shergalis

Art Director, Photographer • Arvid A. Danielson

Administrative Services • Anne S. LoPresti  
European Production Manager • Kurt Hungerbühler

Bulk Rate  
U.S. Postage  
Paid  
Hewlett-Packard  
Company

CHANGE OF ADDRESS: To change your address or delete your name from our mailing list please send us your old address label (it peels off). Send changes to Hewlett-Packard Journal, 1501 Page Mill Road, Palo Alto, California 94304 U.S.A. Allow 60 days.

# HP Archive

This vintage Hewlett-Packard document was  
preserved and distributed by

**[www.hparchive.com](http://www.hparchive.com)**

Please visit us on the web!

On-line curator: John Miles, KE5FX

[jmiles@pop.net](mailto:jmiles@pop.net)

