

MAY 1973

HEWLETT-PACKARD JOURNAL

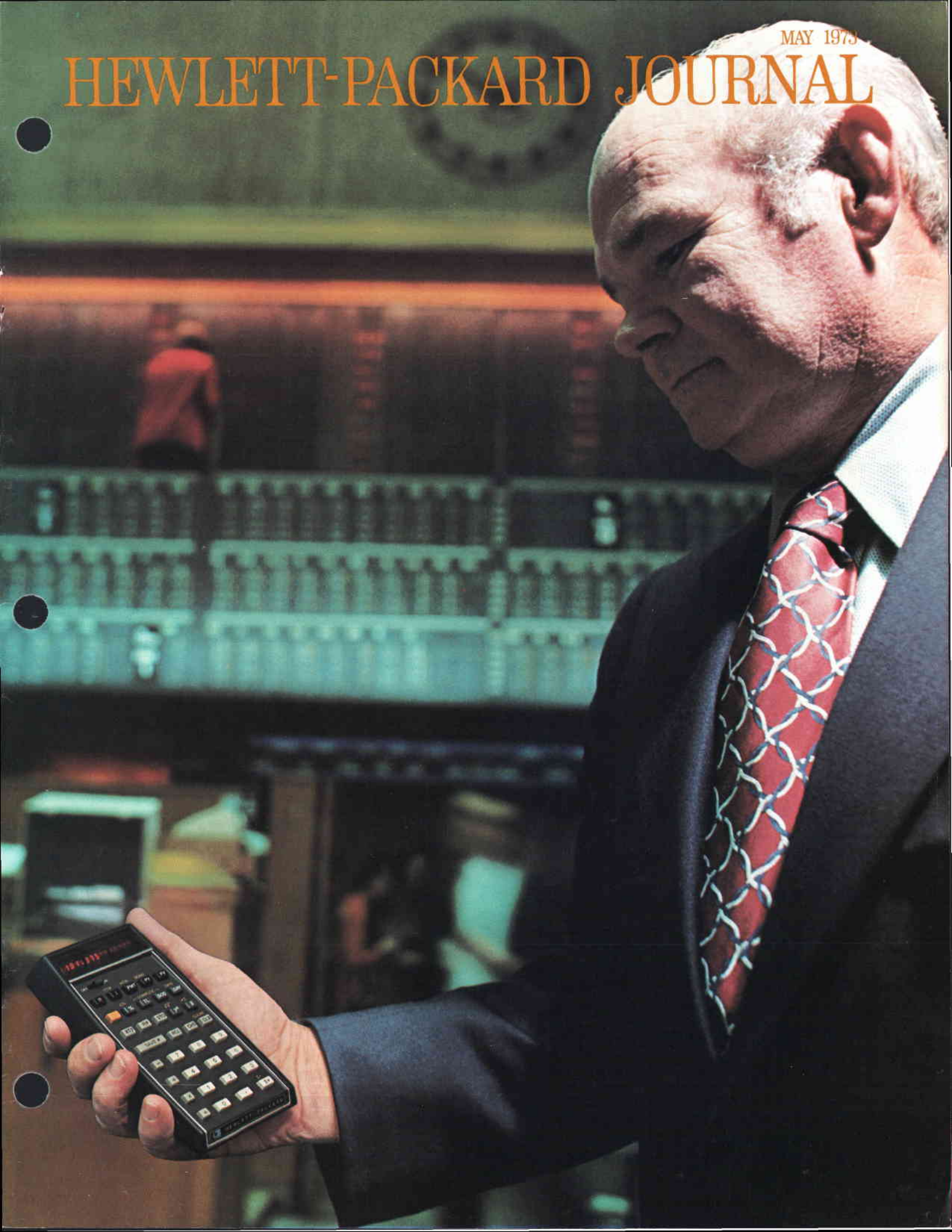

A Pocket-Sized Answer Machine for Business and Finance

This new nine-ounce, battery-powered calculator replaces most commonly used financial tables, such as compound interest, annuities, and bonds. It's also a 200-year calendar.

by William L. Crowley and Francé Rodé

THE WORLD OF BUSINESS AND FINANCE DEPENDS ON THE FLOW OF MONEY—how much is flowing now and over a period of time, the value that people place on it, the expectations and (requirements) of it in the future, and the evaluation of it over some past history.

Accurate measurement of money as related to time is of vital importance to the business and financial community. However, accurate measurements have been difficult because extensive computational and mathematical abilities are required for many critical problems. But now, financial and business people can solve these difficult problems easily with a new tool, the HP-80 Pocket Calculator (Fig 1).

The HP-80 is a preprogrammed computer/calculator designed specifically for financial and business calculations. The HP-80 looks very much like the HP-35, HP's first pocket calculator, which is designed for engineering and scientific work.¹

In fact, the HP-80 and the HP-35 operate the same arithmetically. But the design objectives for the HP-80 were less technical and more problem ori-

ented. We wanted to produce an "answer machine," not an "equation-solver." This meant that the power of the basic HP-35 hardware had to be harnessed in such a way that the real complexity of solving many problems would be invisible to the user. In the final design, the user need only enter the parameters of the problem into the HP-80 and press a key for his answer.

Within the restrictions of the HP-35's architecture and with the help of colleagues on Wall Street and in the various money markets (as well as a little *sensum intestino*), over 30 hard-wired programs were implemented in the HP-80. These programs essentially replace all of the commonly used financial tables, such as compound interest, annuities, bonds, and so on. What's more, other difficult problems, such as time-series linear regression analysis and standard deviation, are made extremely simple. Answers are displayed to as many as six decimal places—more than are given by many

tables. This increased precision is often valuable in bond yield and other critical problems.

One of the more intriguing features of the ma-

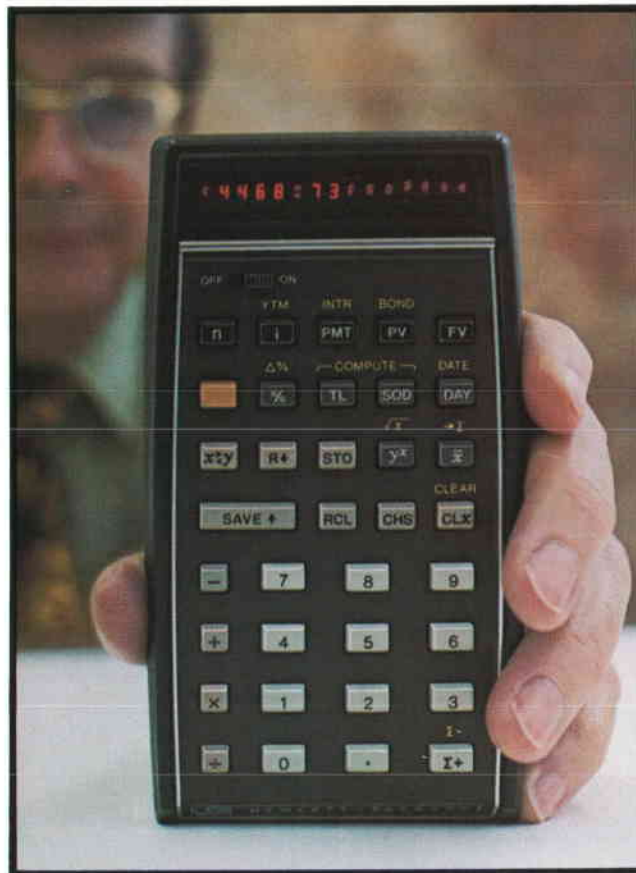

Fig. 1. The HP-80 has a 10-digit display, plus sign and two-digit exponent. It weighs nine ounces and operates from rechargeable batteries or the ac line.

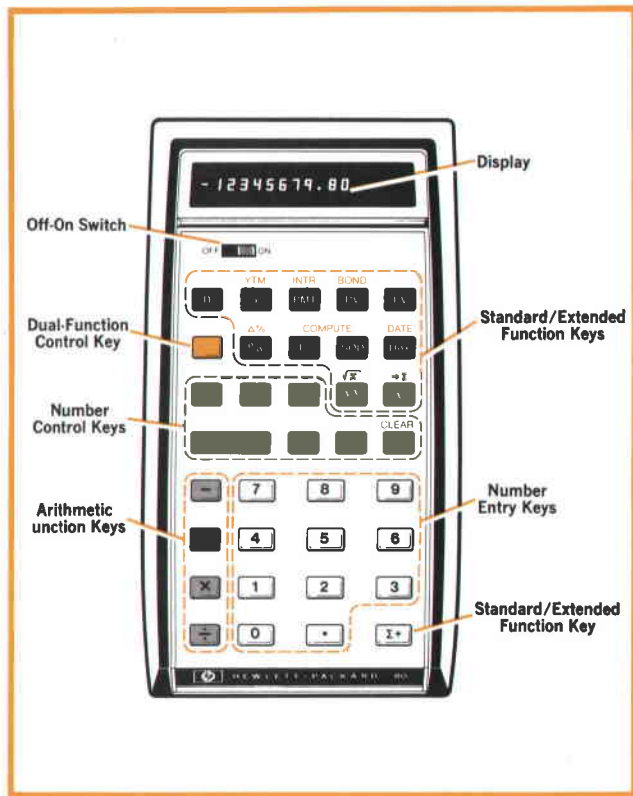

Fig. 2. HP-80 keyboard layout. The gold key converts eleven other keys to their alternate (extended) functions, shown in gold above the keys.



Cover: "Ray Hutchinson at the Pacific Stock Exchange" is a familiar sign-off to listeners of San Francisco radio station KCBS. Art Director Arvid Danielson got the idea for this cover photo of the HP-80 Business Pocket Calculator while driving to work one day listening to the radio, and KCBS business editor Hutchinson and the Pacific Stock Exchange kindly agreed to pose for us.











In this issue:

- A Pocket-Sized Answer Machine for Business and Finance, by William L. Crowley and Francé Rodé **page 2**
- Laboratory Notebook – Thick Films Widen Attenuator Response **page 9**
- A More Rugged, Cleaner Writing Oscillographic Ink Recorder, by Lawrence Brunetti **page 10**
- A Quiet, Low-Cost, High-Speed Line Printer, by Dick B. Barney and James R. Drehle **page 18**

chine is its built-in 200 year calendar. Principally used in practical applications such as note and bond problems (for example, finding a bond yield between any two dates), it is also capable of such "extra-curricular" problems as finding the day of the week on which you were born or the number of days you've been on planet Earth.

The Keys and Their Uses

Fig. 2 shows the HP-80 keyboard layout and nomenclature. The functions of the keys are as follows.

-  The number of time periods pertaining to a particular problem (i.e., the number of days, months, years, etc.).
-  The interest rate as it pertains to a particular problem, expressed as a percent. Use of this key in the extended mode (using the GOLD key prior to this key) refers to yield-to-maturity calculations for bonds.
-  The payment or installment portion of an annuity or the coupon rate of a bond. Extended use of this key refers to the interest payment of a note.
-  The present value or principal as it pertains to a particular problem. Extended use of this key refers to the present value or price of a bond.
-  The future value as it applies to a given problem.
-  GOLD colored key converts other keys to their extended or alternate function.
-  The percentage amount of some base number (e.g., calculates 5% of \$50.00). Extended use of this key will calculate the percent difference between two values.
-  Allows simple calculation of trend lines (by the least-squares linear regression method).
-  Computes amortization schedules using the sum-of-the-digits method. Can use either months or years for finance charge or depreciation.
-  Calculates the difference in calendar days between two dates. Extended use of this key finds a specific date given the number of days.
-  Exchanges the contents of the X-location with that of the Y-location.



Rotates the "stack" of stored values down one location each time this key is pressed.*



Stores a given value into the constant storage location (a separate storage register not in the stack).



Raises a positive number to any power.



Extended use of this key finds the square root of any positive number.



Calculates the mean (arithmetic average) of a series of values previously entered by the summation key Σ+. Extended use of this key allows the user to return to the summing mode for additional observations.



Stores a value into the calculator (not in constant storage) so that it can be operated on by another value and/or function.



Recalls the value stored in the constant storage location.



Changes the sign of the number shown in the display.



Clears the display of whatever is shown. Extended use of this key clears the entire stack (but not the constant storage location).



Sums a series of numbers with the intention of determining a mean and standard deviation. Extended use of this key allows any value to be taken away from the sum, as in the case of an erroneous entry.

Readers familiar with the HP-35 will notice that the SAVE↑ key performs the same function as the HP-35's ENTER↑ key, and that the y^x key does the same thing as the x^y key on the HP-35, but in reverse order. Also, the HP-35 doesn't have the unlabeled gold key. The gold key's purpose is to serve as a shift or control key to execute a function labeled in corresponding gold print above eleven of the HP-80 keys.

Entering an Interest Problem

Where possible the entry of problem parameters has been designed to be as simple and as natural as possible. For instance, the top row of five keys (replacing the basic financial tables commonly used in business and commerce) allows the user to enter

*Like the HP-35, the HP-80 has a four-register operational stack. The four stack registers are named X, Y, Z, and T. The display always shows the number in the X register. Pressing the SAVE↑ key moves the number in X into Y, the number in Y into Z, and the number in Z into T. The number originally in T is lost. The R↓ key moves the number in T into Z, the number in Z into Y, the number in Y into X, and the number in X into T.

SPECIFICATIONS HP-80 Pocket Calculator

BASIC HP-80 CAPABILITIES

1. Add
2. Subtract
3. Multiply
4. Divide
5. Constant storage
6. Selective round-off
7. Percent calculation
8. Percentage difference
9. Square root
10. Exponentiation
11. Running total (summation)
12. Mean (arithmetic average)
13. Standard deviation
14. Number of days between two dates
15. Future date given number of days
16. Future value of an amount compounded
17. Present value of an amount compounded
18. Effective rate of return for compounded amounts
19. Number of periods required, given rate, principal and future value
20. Future value of an annuity
21. Present value of an annuity
22. Effective rate per period, given the future value and payment of an annuity
23. Effective rate per period, given the present value and payment of an annuity
24. Payment or installment of an annuity given future value
25. Payment or installment of an annuity given present value
26. Number of periods given the rate, payment and future value of an annuity
27. Number of periods given the rate, payment and present value of an annuity
28. Add-on to effective annual rate conversion
29. True effective annual yield
30. Linear regression (trend-line) forecasting
31. Sum-of-the-years digits depreciation amortization
32. Sum-of-the-months digits finance charge amortization
33. Discounted cash flow analysis
34. Accumulated mortgage interest paid
35. Remaining principal on a mortgage
36. Accrued interest (360 and 365 day year)
37. Discounted notes (360 and 365 day year)
38. Effective yield on discounted notes (360 and 365 day year)
39. Bond price
40. Yield-to-maturity of a bond

PRICE IN U.S.A.: \$395.00

MANUFACTURING DIVISION: ADVANCED PRODUCTS DIVISION
10900 Wolfe Road
Cupertino, California 95014

his data in a natural, left-to-right sequence.

As an example, consider the following problem. What is the effective compounded rate of growth required to double the worth of an investment over 8¼ years? To solve for "i," the interest rate per period, simply enter the known parameters as follows (assume the present value of the investment is \$1 and the future value is \$2):

8.25 1 2 → 8.76 (%)

Any of the five elements of a compound interest problem can be found by simply entering the known values in left-to-right fashion and pressing the key bearing the symbol corresponding to the unknown value. In this way, we have tried to reduce the complexity of a financial concept to the simplicity of a single function.

Examples of HP-80 Solutions

Percent Difference Between Two Numbers

To find the percent difference between two numbers, enter the base number and press

SAVE \rightarrow . Enter the second number, press **DEL** $\Delta\%$

For example,

ENTER:
60 **SAVE** \rightarrow 240 **DEL** $\Delta\%$ \rightarrow **SEE DISPLAYED:**
300% (240 is 300% greater than 60)

Day of the Week

Suppose today is Monday, January 22, 1973, and you wanted to find out what day it was when the stock market crashed on October 29, 1929.

ENTER:
10.291929 **SAVE** \rightarrow 1.221973
DAY **SAVE** \rightarrow 7 **+ \rightarrow **2255.86**
2255 **-** 7 **X** \rightarrow **6.00** day factor**

Today is Monday; count six days back to get Black Tuesday.

Accumulated Interest Between Two Points, Remaining Principal

You have a 30-year, 8% mortgage on your house in the amount of \$40,885 which you obtained 4 1/3 years ago. Monthly payments are \$300. What is the amount of interest paid during the taxable year just ended starting at payment 40 and ending at payment 52? What is the unpaid principal?

Solution

ENTER:
40 **STO** 52 **n** 360 **n**
8 **SAVE** \rightarrow 12 **+ **i** 300 **PMT** **Σ+** \rightarrow \$ 3154.48 interest
Σ+ \rightarrow \$ 39186.73 remaining principal**

Discounted Cash Flow Analysis

You are offered an investment opportunity for \$100,000 at a capital cost of 10% after taxes. Will this investment be profitable based on the following cash flows?

Year	Cash Flow
1	\$34,000
2	\$27,500
3	\$59,700
4	\$ 7,800

Solution

ENTER:
10 **i** 100000 **CHS** **PV** 34000 **PV** **Σ+** \rightarrow \$ -69090.91 current net present value
27500 **PV** **Σ+** \rightarrow \$ -46363.64 current net present value
59700 **PV** **Σ+** \rightarrow \$ 10000.00 current net present value
7800 **PV** **Σ+** \rightarrow \$ 3817.36 final value is positive deal is OK

A Bond Problem

The general equation for the price of a corporate bond in the United States is:

$$p = -100 \left(\frac{a}{2} \right) \left(\frac{180 - b}{180} \right) + \left[\sum_{k=1}^c \frac{100 \left(\frac{a}{2} \right)}{\left(1 + \frac{m}{2} \right)^{k-1 + (b/180)}} \right] + \frac{100}{\left(1 + \frac{m}{2} \right)^{c-1 + (b/180)}}$$

where:

- p = price of bond expressed as a percent
- a = annual interest rate payable semi-annually; the interest is expressed as a decimal
- b = number of days before the next coupon is payable
- c = number of coupons payable between the present and maturity
- m = annual yield to maturity, compounded semi-annually; the yield is expressed as a decimal.

One can imagine how difficult it would be to solve for the yield to maturity, m! With the HP-80, the solution is simple. For example, what is the yield to maturity of a bond bearing a 5% coupon, maturing in 5 years and selling at 94 1/2?

To obtain yield to maturity, enter the following in left-to-right sequence and see the answer 6.30 (%) displayed.

5 **SAVE** \rightarrow 365 **X** **n** 5 **PMT** 94.5 **PV** **YTM** \rightarrow 6.30 (%)

Trend Lines

The HP-80 can be used to find the least-squares linear approximation to a time series and extrapolate it into the past or future. The technique is known as linear regression or trend-line analysis.

For example, using linear regression, calculate a projected value for sales in the seventh month if actual sales for the first six months are 486, 437, 506, 470, 523, 512, 512.

HP-80 solution:

486 **TL** 437 **TL** 506 **TL** 470 **TL** 523 **TL** 512 **TL** **TL**
7 **n** **TL** \rightarrow 524.20

Conventional solution:

$$Y_x = A + BX$$

where:

- Y_x = value on the trend line at the point in time X
- A = value of the trend line at the origin (X = 0)
- B = amount of change in the trend line value per unit of time X
- X = units of time

$$B = \frac{2 \sum_{K=1}^n KY_K - (n+1) \sum_{K=1}^n Y_K}{\frac{n(n^2-1)}{6}} = 10.06$$

$$A = \frac{1}{n} \sum_{K=1}^n Y_K - \left(\frac{n+1}{2}\right) (B) = 453.79$$

$$\text{Then } Y_7 = 453.79 + (10.06)(7) = 524.20$$

Other Capabilities

A list of the HP-80's basic capabilities appears on

page 4 . More complex problems can be solved by combining these basic capabilities. Additional examples of problem solutions are on page 5 .

Inside the HP-80

Architecturally, the HP-80 is essentially the same as the HP-35¹, so instead of describing its architecture completely we'll highlight only the differences.

In many respects the HP-80 is more like a computer than a calculator. It has a microprogrammed instruction set that is essentially the same as the

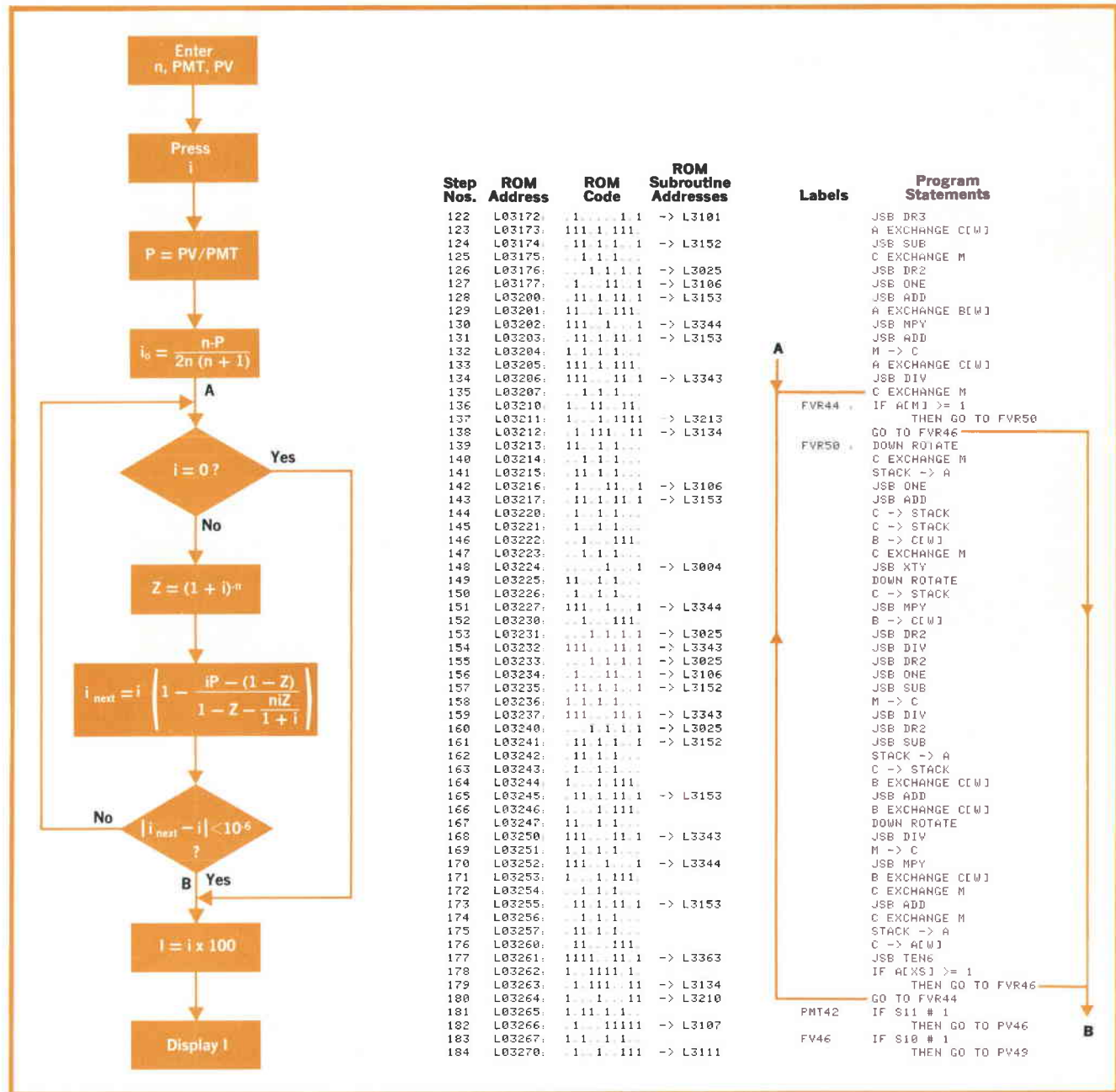

Fig. 3. HP-80 algorithm for finding interest rate given present value, payment, and number of periods. Also shown is a partial listing of the program that implements the algorithm.

HP-35's except that trigonometric functions are excluded. But the HP-80 also has another level of programming that uses the basic functions (+, -, ×, ÷, y^x, ln x, etc.) as subroutines. Also, some of the more frequently used register manipulation routines are incorporated as subroutines in the HP-80 to save memory space.

An example of HP-80 programming is shown in Fig. 3. The flow chart shows the algorithm used to solve for the interest *i* in the equation

$$PV = PMT \frac{1 - (1 + i)^{-n}}{i}$$

See Appendix A for the derivation of the algorithm.

The equation is solved by an iterative technique. The program listing shown in Fig. 3 is the portion of the program that implements the iteration sequence (that is, the part between A and B in the flow chart).

Both the microcode and the higher-level code in the HP-80 are implemented in read-only memories (ROMs). Where the HP-35 had three ROMs the HP-80 has seven. The seven ROMs are mounted on a hybrid circuit to form a single assembly (Fig. 4). The hybrid approach makes final assembly easier and allows use of a less expensive circuit mounting board.

Accuracy

Accuracy of the HP-80 varies according to the operation being performed.

Arithmetic operations (+, -, ×, ÷) are accurate to 10 digits ± 1 count; that is, the value of the 10th digit could be 1 less or 1 more than the value displayed.

Special operations solved through an iterative method (*bond yields, effective yield of an annuity, and add-on to effective annual rate conversion problems*) use numerical analysis techniques formerly requiring computers or large-scale programmable calculators. These operations are accurate to 5 digits.

All other operations are accurate to 9 digits ± 1 count; the value of the 9th digit could be 1 less or 1 more than the value displayed.

Bond yield calculations may result in slightly reduced accuracy if the problem is an unusual case such as calculating a 50% yield-to-maturity for a 2% bond. For example, the yield-to-maturity on a 2% bond, maturing in 3 years, 3 months and selling at 26.481133 is 50.00%. The answer displayed is 49.99%. The formula for determining error magnitude is: percent calculation error for bond yield ≤ 2 × yield (actual) × coupon × 10⁻⁴. The operating limits for the bond yield algorithm are defined such that the price of the bond must be above 20 and below 5,000, and coupon must be greater than 1/8%

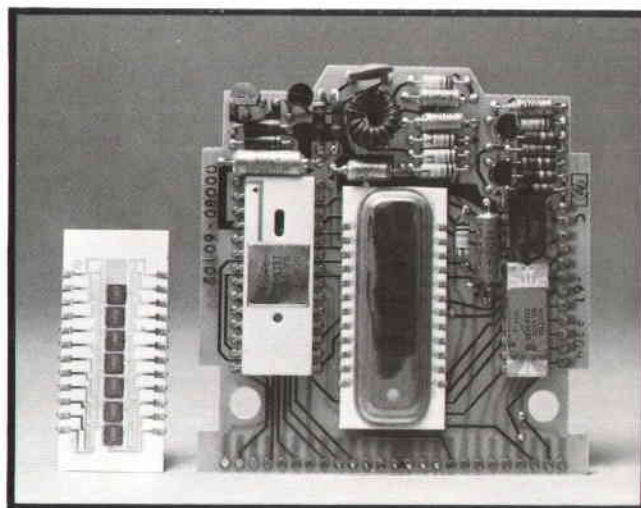

Fig. 4. HP-80 programs are stored in seven read-only-memory chips mounted on a hybrid circuit.

and less than the price of the bond (expressed as a percent of par).

Error Indicators

Any computation or data entry resulting in a magnitude greater than or equal to 10¹⁰⁰, or less than 10⁻⁹⁹, triggers an error signal indicated by a blinking display.

If a calculation is attempted that contains a logical error—say division by zero—an error signal is triggered and a blinking display appears. To reset, press CLX. Examples of logical errors are division by zero, y^x where y ≤ 0, and date/day calculations where the range is exceeded, a date entered doesn't exist, or date-entry conventions aren't followed.

Acknowledgments

The individuals who helped with the HP-80 development did so with a spirit of immense teamwork. Particular appreciation is given to the following: Barney Oliver for his insistence and guidance on fundamental product excellence that only a mind of his scope and experience can provide. Paul Stoft and Tom Whitney for their assistance in providing technical aid and coordination of resources. Sandy Walker for providing valuable assistance on many of the "tricky" algorithms implemented in the HP-80. Dave Cochran for his assistance in implementing and consulting on some very clever microprogramming. Darrel Lauer for his superb job in implementing a keyboard set that defied many physical limitations. Ken Peterson and the Loveland Division IC department for the hybrid ROM circuit. The HP finance and accounting personnel who provided helpful comments and suggestions. And Bill Hewlett, who gave us the trust and freedom that allowed all of this to happen. 📄

APPENDIX A

A Typical HP-80 Algorithm

Some of the functions incorporated into the HP-80 are implicit functions of i and must be solved by iterative techniques. Since we are register and ROM limited, the algorithms had to be as compact and efficient as possible.

For a variety of reasons the best technique to try is the Newton-Raphson one² and this was used for the annuity functions. Take the equation

$$PV = PMT \frac{1 - (1 + i)^{-n}}{i}$$

We wish to solve for i knowing the rest of the variables. Rewriting this as a function of i ,

$$f(i) = \frac{PV}{PMT} - \frac{1 - (1 + i)^{-n}}{i} \quad (1)$$

and we are solving for $f(i) = 0$. First we sum the first three terms of the binomial expansion for $f(i)$ and solve for i . This gives us i_0 , the starting value. Thus

$$i_0 = \frac{2(n - PV/PMT)}{n(n + 1)}$$

We now look for some relationship that will give us $i_1, i_2, \dots, i_k, i_{k+1}$ successively such that for some k

$$|i_k - i_{k+1}| < \text{error limit we require}$$

The diagram shows that if $f(i_{k+1})$ is very small, the following relationship holds for $df(i_k)/di_k$.

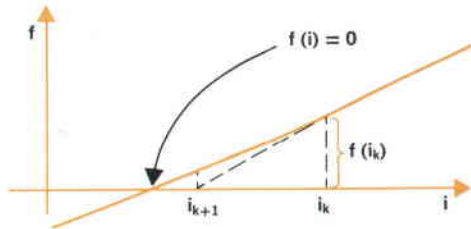

$$f'(i_k) \approx \frac{f(i_k)}{i_k - i_{k+1}}$$

so that

$$i_{k+1} = i_k - \frac{f(i_k)}{f'(i_k)} \quad (2)$$

Basically we slide down the curve sawtoothing into the solution with this relationship. If $f(i)$ is very steep we may take a lot of sawtoothing into the required accuracy. Converting this to an algorithm is just:—

1. $i \leftarrow i_0$ feed into i the starting value
- 1: $i_{next} \leftarrow i - f(i)/f'(i)$ compute next i value
- 1: $i_{next} - i < 10^{-6}$ (say) check convergence to accuracy required
- If yes then exit
- If no then $i \leftarrow i_{next}$ and go to 1 to compute $(i_{next})_{next}$.

This is the Newton-Raphson technique.

For the function $f(i)$ defined in equation 1, i_{next} is derived as follows:

$$f'(i) = -\frac{n(1+i)^{-n}}{1+(1+i)} + \frac{1 - (1+i)^{-n}}{i^2}$$

Let $P = PV/PMT$ and $Z = (1+i)^{-n}$.

Then

$$\begin{aligned} i_{next} &= i - \frac{f(i)}{f'(i)} = i - \frac{iP - (1-Z)}{\frac{1}{i^2} \left[(1-Z) - \frac{niz}{1+i} \right]} \\ &= i \left[1 - \frac{iP - (1-Z)}{1-Z - \frac{niz}{1+i}} \right] \quad (3) \end{aligned}$$

Fig. 3, page 6 shows the flow diagram and HP-80 program listing to solve equation 1 using the Newton-Raphson technique and i_{next} as defined by equation 3.

APPENDIX B

Principal HP-80 Equations

1. $FV = PV(1+i)^n$
 FV = future value, PV = present value, n = number of periods,
 i = interest per period.

2. $FV = PMT \frac{(1+i)^n - 1}{i}$
 PMT = payment

3. $PV = PMT \frac{1 - (1+i)^{-n}}{i}$

4. $I_{J-K} = PMT \left[K - J - \frac{(1+i)^{K-n}}{i} + \frac{(1+i)^{J-n}}{i} \right]$
 I_{J-K} = interest from payment J to payment K

5. $PV_k = \frac{PMT}{i} \left[1 - (1+i)^{-k} \right]$

PV_k = remaining balance after payment K

6. Discounted Note Calculations
 $D = \frac{FVni}{N}$ $Y = \frac{ND}{n(FV - D)}$

D = discount rate, Y = yield, $N = 360$ or 365 (usually 360 in U.S.A.)

7. Depreciation
 $dep_k = \frac{2(n-k+1)}{n(n+1)} PV$

dep_k = depreciation for k th period using sum-of-digits (SOD) method.

8. Bond Price*

For $n \geq 182.5$ (days between purchase and maturity)

$$p = 100 \left(1 + \frac{m}{2} \right)^{-n/182.5} + 100 \left(\frac{a}{i} \right) \cdot \left[(1 + \frac{m}{2})^J - (1 + \frac{m}{2})^{-n/182.5} \right] - 100 \left(\frac{a}{2} \right) J$$

For $n < 182.5$

$$p = \frac{200 + 100a}{2 + nm/180} - (1 - n/180) 100 \left(\frac{a}{2} \right)$$

p = bond price (based on 360 or 365 day year, depending upon how n is computed), a = coupon rate expressed as a decimal on an annual basis, m = annual interest called *annual yield to maturity* expressed as a decimal, $J = 1 - b/180$, b = number of days before next coupon is payable.

*Note: This is a more general form of the equation shown on page 5.

9. Trend Lines

$Y_x = A + BX$

Y_x = value of trend line at point in time X , A = value at $X = 0$,
 B = slope of trend line.

$$B = \frac{2 \sum_{K=1}^n KY_k - (n+1) \sum_{K=1}^n Y_k}{n(n^2 - 1)/6}$$

$$A = \frac{1}{n} \sum_{K=1}^n Y_k - \left(\frac{n+1}{2} \right) B$$

n = number of time points for which data is available.

$K = 1, 2, \dots, n$.

Y_k = trend line value at K th time point.

10. Standard Deviation

$$S_x = \sqrt{\frac{1}{n-1} \left(\sum_{i=1}^n x_i^2 - n\bar{x}^2 \right)}$$

S_x = standard deviation of variable x , n = number of samples of x ,
 \bar{x} = mean value of x , $i = 1, 2, \dots, n$.

11. Discounted Cash Flow Analysis (Net Present Value)

$$NPV = \sum_{k=0}^n C_k (1+i)^{-k}$$

NPV = net present value, i = discount rate expressed as a decimal,
 n = number of cash flows, C_k = cash flow in k th period, $k = 1, 2, \dots, n$.

References

1. T. M. Whitney, F. Rodé, and C. C. Tung, "The Powerful Pockeful: an Electronic Calculator Challenges the Slide Rule," *Hewlett-Packard Journal*, June 1972.
2. C. Jordan, "Calculus of Finite Differences," Chelsea Publishing Company, New York, 1965. Page 489.



Francé Rodé

Francé Rodé came to HP in 1962, designed counter circuits for two years, then headed the group that developed the arithmetic unit of the 5360 Computing Counter. He left HP in 1969 to join a small new company, and in 1970 he came back to HP Laboratories. He designed the arithmetic and register circuit and two of the special bipolar chips for the HP-35, HP's first pocket calculator, and he was project leader of the HP-80 development team, designing the hardware while Bill Crowley developed the algorithms. Francé holds the degree Diploma Engineer from Ljubljana University in Yugoslavia. In 1962 he received the MSEE degree from Northwestern University. When he isn't designing logic circuits he likes to ski, play chess, or paint.



William L. Crowley

Bill Crowley, HP's corporate cash manager, was half of the two-man team that developed the HP-80. Bill contributed the algorithms and Francé Rodé designed them into hardware. Bill received his BS degree in mechanical engineering in 1964 from Texas A & M University and his MBA degree in 1967 from the University of Texas. During the next 18 months he started two companies dealing in software system consulting and investment management, and developed and published a statistical model for security price forecasting. In 1969 he sold his businesses and joined HP, becoming cash manager 18 months later. Investments, computers, and financial history occupy a good deal of Bill's spare time, too, but occasionally he stops thinking about money and enjoys backpacking, ski touring, photography, and music.

Laboratory Notebook *

Thick Films Widen Attenuator Response

In designing an oscilloscope for high-frequency performance, the attenuator can be as much a problem as the amplifiers. The inevitable distributed capacitance and inductance work against obtaining both high impedance and accurate attenuation simultaneously over a broad range of frequencies. With conventional rotary switches and discrete resistors, 75 MHz has been about the limit for 1-megohm oscilloscope attenuators.

The attenuator in late-model HP high-frequency oscilloscopes overcomes this limit by using thick-film resistors and conductors deposited on an alumina substrate. The attenuator is switched by spring fingers that make contact to the conductors when depressed by plastic rods that are in turn actuated by cams on the switch shaft. Conductor paths are thereby shortened considerably and as a result, series inductance, the major cause of poor attenuator performance at high frequencies, is reduced as much as five times.

Accumulated stray capacitance, which usually seemed to amount to at least 24 pF at the input of conventional attenuators, is less than 13 pF. This doubles the frequency range over which high-impedance probing may be performed without serious loading of the circuits under test. Furthermore, circuit paths are much more uniform from attenuator to attenuator, reducing the need for excess compensation to take care of all variables.

The attenuator has 1-megohm input resistance. The physical design, however, also made it possible to include a

switchable 50Ω termination at the input. Since the input, including the connector and switch, can be made part of a 50Ω line right up to the termination, this makes a clean 50Ω input impedance available for the oscilloscope. As a result, VSWR with the 50Ω termination switched in is only 1.2 at 100 MHz on all attenuator ranges, much better than that obtainable using an external termination. Accurate transition-time measurements on 50Ω circuits can thus be made with no risetime degradation attributable to the scope input. The 2-watt capability of the 50Ω termination allows input signals as large as 10 volts rms.

The entire attenuator is fabricated with only one conductor and two resistor screenings, one at 100k ohms per square and one at 30 ohms per square. The resistors are trimmed on the substrate to an accuracy of 0.5%, allowing the entire attenuator to be specified conservatively to an accuracy of ±2%. Temperature coefficient is 100 ppm/°C with tracking within 25 ppm/°C.

Instruments using this attenuator include the Model 1710A 150-MHz Portable Oscilloscope, the Models 1805A 100-MHz and 1808A 75-MHz Vertical Amplifier plug-ins for the 180-series Oscilloscope, and the Model 1834A 4-Channel 200-MHz Vertical Amplifier plug-in for the 183-series.

— Thomas Zamborelli
Colorado Springs Division

*Editors' note: "Laboratory Notebook" is a new editorial feature that describes individual developments of note. It will appear on an intermittent basis.

A More Rugged, Cleaner Writing Oscillographic Ink Recorder

This new oscillographic recording system features a reliable low-pressure ink system, instant-dry near-black ink, plug-in versatility, and a rugged, serviceable design.

by Lawrence Brunetti

SINCE 1948, when the first direct-writing oscillographic recorder* was developed for medical applications, the principal evolutionary changes in these recorders have occurred in their writing systems. Today, the search still goes on for a writing system as convenient and rugged as the newest thermal system,¹ yet with the economy, resolution, reproducibility, and permanence of ink.

During the 1960's the aerospace industry's need for better accuracy, reliability, and high-speed writing performance spurred the development of the pressurized ink system. This system used high-pressure, high-viscosity ink to overcome inertial effects within the pen tube and assure a continuous flow of ink even at high pen velocities. These recorders also used servo feedback to overcome most of the nonlinearity, drift, and deadband effects inherent in spring-restored galvanometer systems.

The high-pressure ink recorder was far superior to any other ink recorder available at the time. However, it still had disadvantages. The combination of high-viscosity ink and high pen velocity caused a hydroplaning effect similar to automotive tires skidding on wet pavement. This resulted in a trace with a wet surface coating of ink that didn't dry on contact. The wet trace could cause reprinting of the record as the chart passed through the drive rollers and it could be easily smeared as the high-speed chart emerged from the recorder. Also, the pens were made of aluminum, and fatigue failures were common under heavy use, particularly in telemetry systems, where a noisy, unlocked discriminator might destroy a stylus in minutes.

*Direct-writing oscillographic recorders differ from strip-chart recorders mainly in their ability to record fast-changing signals. Strip chart recorders perform well only up to about 10 Hz whereas some direct-writing oscillographic recorders are useful to over 100 Hz. However, oscillographic recorders are usually less accurate than strip chart recorders when recording slowly changing signals.

Today the major application of oscillographs is neither medical nor aerospace but industrial. The ink-writing oscillograph is now a standard design and production tool for the process-control engineer, the noise and vibration laboratory, and the film manufacturer, to name but a few users.

The changing role of the oscillograph from medical and aerospace to industrial applications has prompted a re-evaluation of the kind of recorder that can best serve the industrial user. It has become clear that what is needed is a new oscillograph with a simpler, non-clogging ink system and a more reliable stylus that can stand up under severe operating conditions.

New Recorder

The new Model 7402A Oscillographic Recorder, Fig. 1, is designed to meet these requirements. This new two-channel ink-writing oscillograph uses rugged stainless-steel pens and a low-viscosity ink that dries on contact even when writing a high-frequency waveform at slow chart speeds. The trace is blue-black in color, very close to black, and reproduces easily. The ink system design assures uniform trace width and density even under conditions of transient changes in chart or pen speeds.

Each of the 7402A's two channels is a full 50 millimeters wide. An unusual feature is the ability to operate in a single-channel 100-mm-wide mode (see box, page 14).

Plug-in preamplifiers, one for each channel, allow the user to tailor the recorder to fit his application. Internally, the design is modular for easy servicing. The paper-feed system is easy to load and is self-aligning.

Standard in the mainframe are inputs for remote control of chart speeds—including chart stop—by TTL logic levels or contact closures. Optional are

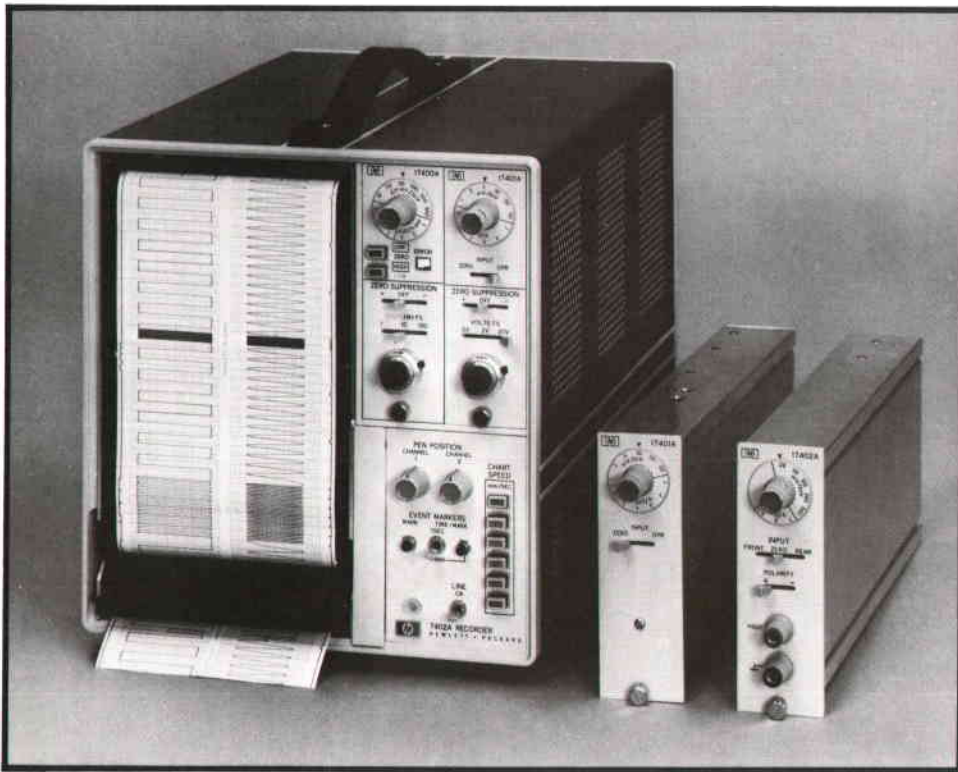

Fig. 1. Model 7402A Oscilloscope Ink Recorder has two 50-millimeter-wide channels, each with its own plug-in preamplifier. It can also be used in a single-channel, 100-mm-wide mode.

two event markers and a timer, controlled either from the front panel or by TTL inputs. Rear-panel preamplifier outputs are available for systems applications. A rack mounting kit and a paper takeup system are optional.

Pen Fatigue Failures Eliminated

The pens used in the 7402A have precipitation-hardened stainless-steel bodies and tungsten carbide tips. Unlike aluminum, stainless steel has predictable fatigue characteristics, so the pens can be designed to eliminate the most common cause of aluminum stylus failure—that due to fatigue. The tungsten carbide tips eliminate the need for replacement due to worn-out tips. Thus the pens should never need replacement.

For a given area moment of inertia, the stainless steel stylus results in an increase in torsional rigidity. This increased rigidity, in combination with a teflon-coated tip virtually eliminates the plague of “spitting” or ink throwing at high speed.

High-Performance Servo System

The pen-motor servo system in the 7402A uses a contactless-differential-capacitor pen-position transducer.¹ Fig. 2 is a diagram of the servo system.

The simple stylus and linkage mechanism (Fig. 3) and the stainless-steel pens result in a stiff rugged design that has a resonant frequency twice that of existing designs. As Fig. 4 shows, the servo-stylus resonance has been extended to over 900 Hz. Be-

cause of this high resonance frequency and the inherent ruggedness of the pen, no input signal can damage the pen.

The high stylus resonant frequency allows additional phase compensation at the gain crossover frequency of 250 Hz. This gives the 7402A excellent square-wave response (Fig. 5). Sharp electrical limiting provides protection for the pens without compromising linearity at the chart edges.

Ink System

The 7402A uses simple two-component ink. It consists only of solvent and dye. There are no pigments or resins to produce clots that might clog the 0.010 inch stylus tips. Ink viscosity is low (between 0.05 and 0.3 poise) so wet traces at high speed are eliminated—hence, “instant-dry ink.”

Because of the low viscosity, a low pressure system is used to achieve good low-speed writing quality. The low pressure, however, isn't adequate to provide continuous traces at high speed. In the past, various methods to modulate the ink pressure have been used, the simplest being to increase the pressure until the undesired skipping was eliminated. The 7402A solution makes use of dynamic forces within the ink column in the stylus, resulting in an adaptive pressure system.

To produce a constant width line, the ink pressure at the pen tip should increase as the pen tip velocity increases. The ink system is pressurized at a basic low value of 4 psi. Pen movement causes

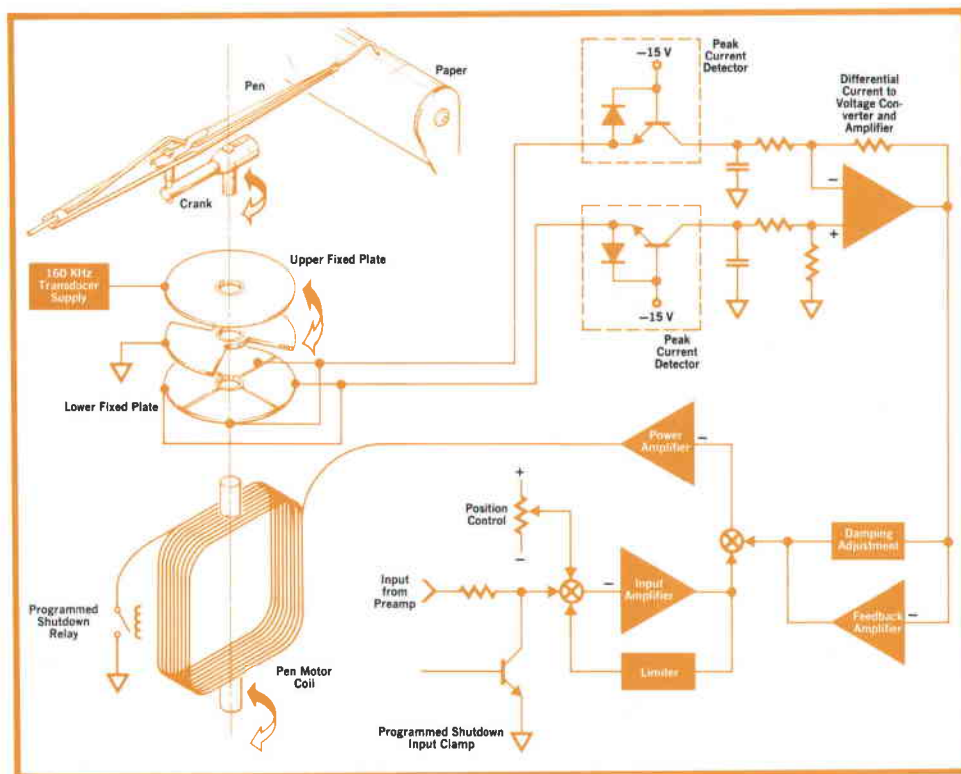

Fig. 2. 7402A servo system uses contactless position feedback. Programmed control of the pens is maintained under all operating conditions.

pressure changes within the main pen tube. A rubber accumulator near the pen tip (Fig. 6) stores these changes and provides a net increase in pressure. Thus, the ink pressure is increased only when it is needed, at high pen velocity.

The Appendix contains an analysis of the ink system and the effect of the accumulator.

Fig. 7 is a diagram of the ink system. During ink flow, the ink is allowed to pass into the distribution manifold by the main valve which acts as a switch. The main valve closes when the chart is stopped, when the chart magazine is opened, when the chart paper supply is exhausted, or when power is turned off. The bleed-down valve is used in a pulsed fashion to depressurize the ink system when the main valve is switched off.

The disposable ink cartridge has a capacity of 55 cc, enough for a single pen to write 250 miles or about six months of recording for an average user.

Stylus Always Under Control

Typically, recorder servos are uncontrolled when power is being turned on or off. This can result in an annoying whip of the pens, and in some cases, throwing of ink. In the 7402A, programmed control is maintained through all phases of power on or off, chart start and stop, when the paper platen is inadvertently opened during operation, or when the paper supply is exhausted. Programmed control for shutdown is accomplished by first setting the in-

puts from the plug-in preamplifiers momentarily to zero by energizing the input clamp (see Fig. 2). This causes the stylus to return to a position determined by the position control setting. After a delay of 15ms, the shutdown relay is de-energized, opening the servo loop.

During the programmed servo shutdown, the ink system is also predictably shut off by the main and bleed-down valves. The disposable ink cartridge becomes the receptacle for excess ink forced out of the system during depressurization.

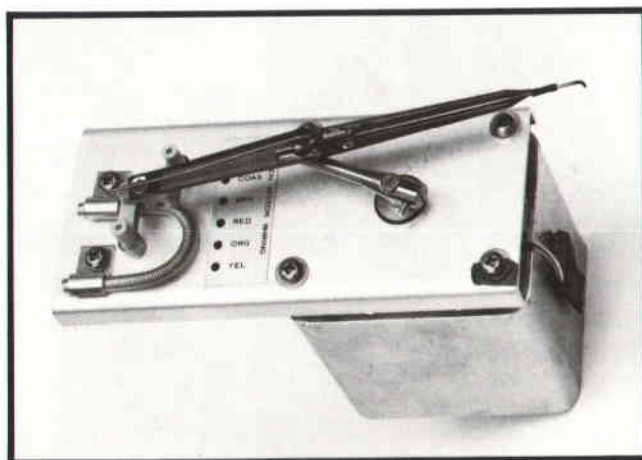

Fig. 3. Simple, linear, stylus linkage and stiff, rugged stainless-steel pens make for a reliable system that is difficult to damage. Pens are easily replaced and require no manual lapping.

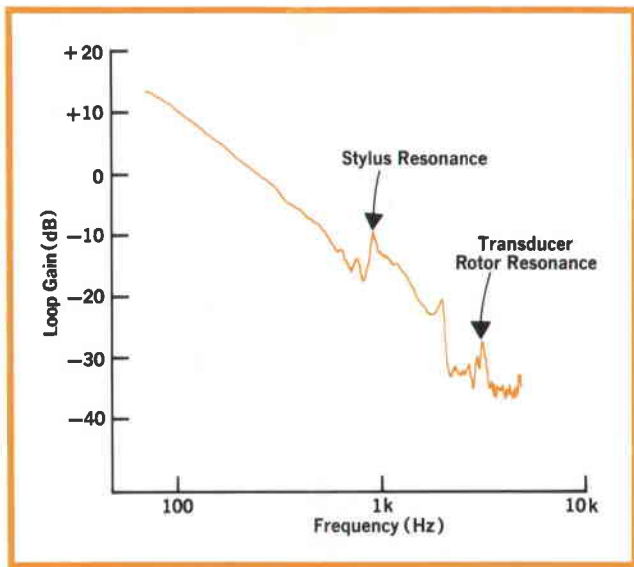

Fig. 4. Loop gain of a typical 7402A servo system. 900-Hz stylus resonance is twice that of older designs.

User-Oriented Plug-in Preamplifiers

The 7402A's plug-in preamplifiers offer a range of performance levels and operator-oriented controls. The 17400A High-Gain Preamplifier has input

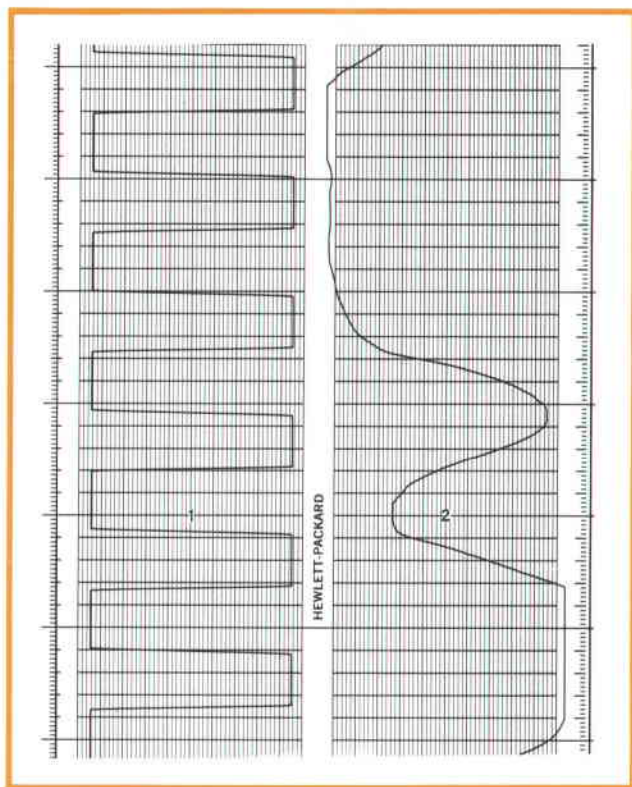

Fig. 5. Channel 1 shows 7402A response to a square wave input (<30 ns rise time). Channel 2 shows sharp electrical limiting that protects the pens without compromising linearity at the edges.

sensitivities of $1\mu\text{V}$ to 5 volts per millimeter, 140 dB common mode rejection at 60 Hz, and up to two decades of calibrated zero suppression. It also has an error indicator that tells when the switch settings are incompatible or when the input is overloaded. Simplified controls "talk" to the user; for example, if the operator wants to move the trace to the right with zero suppression, he simply moves the polarity lever to the right.

Since the accuracy of the servo system eliminates the need for front-panel calibration controls, the 17400A has only a range vernier, with a calibrated detent similar to oscilloscopes.

The 17402A Low-Gain Preamplifier fits the single-ended-signal application. It has polarity reversal switch, isolated front and rear panel inputs for systems, and a 1, 2, 5 sequence of calibrated input sensitivities from 20 mV to 5V per millimeter. The 17401A is the workhorse of the line. It has input sensitivities of 1 mV to 5V per millimeter, 50 dB common mode rejection, and optional calibrated zero suppression up to 20 Volts.

Like the 17400A, the 17401A and 17402A plug-ins have no calibration adjustments on their front panels. The accurate servo system makes them unnecessary. Position controls have been removed from all the plug-ins and put in the mainframe. This not only allows the plug-ins to be simpler, but is the key to the unique one-channel mode (see box, page 14).

Modular Design

In the design of today's products, reliability is a prime consideration, but no matter how carefully a product is designed for worst-case conditions, sometime during its life some maintenance is likely to be required. For this reason the 7402A is highly

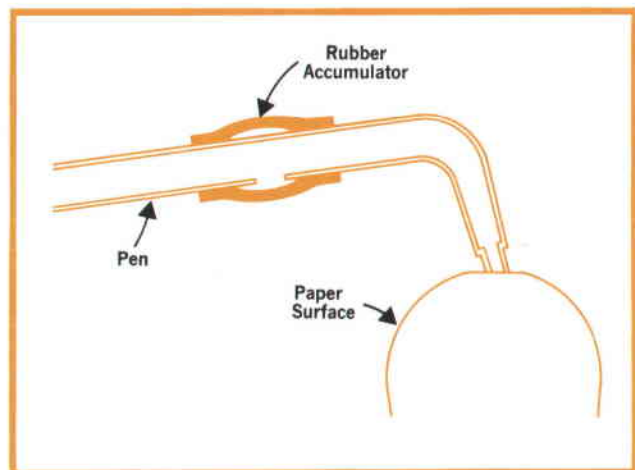

Fig. 6. Accumulator stores dynamic pressure fluctuations within the stylus and provides a net increase in pressure to maintain a constant-width trace at high pen velocity.

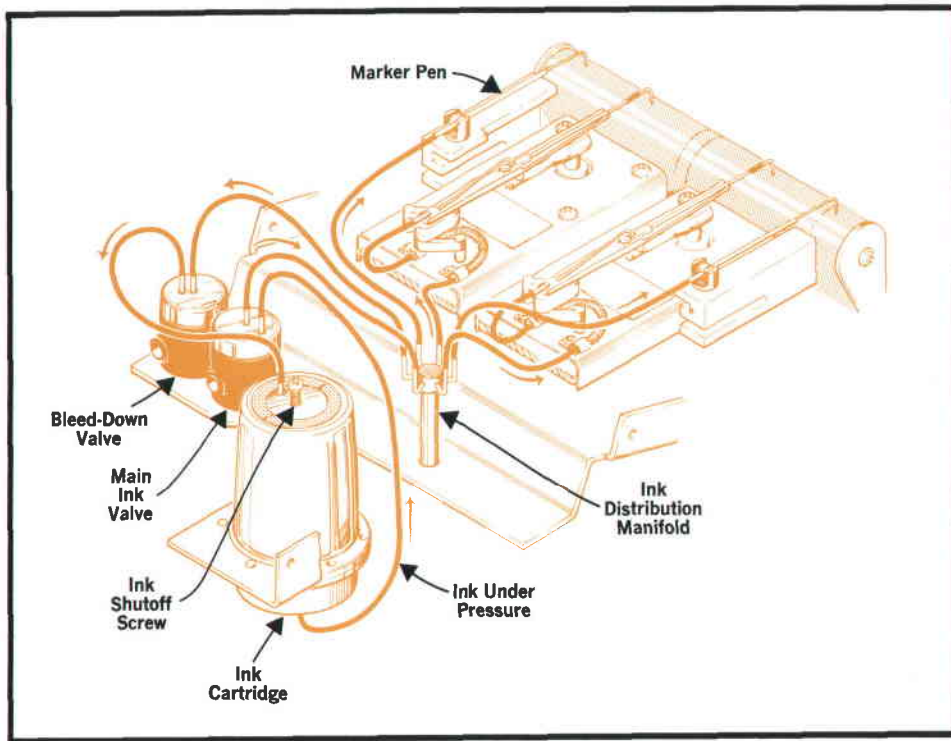

Fig. 7. Disposable cartridge holds enough ink for about six months' operation. Main valve shuts off the ink supply when operation stops for any reason. Then the bleed-down valve is used in a pulsed fashion to depressurize the system.

modular and easy to service. All electronics are available on functional plug-in cards at the rear; each board performs a single function. The recorder module itself is removable from the mainframe and

can be operated in this configuration by means of an umbilical. Pen motors, transducers, transmission, and mother board are all replaceable as modules.

Single-Channel 100-mm-Wide Recording

A direct writing oscillograph typically presents data on 40- or 50-millimeter-wide channels with a full-scale frequency response in the order of 35 to 55 Hz. In some applications, even the 50-mm-wide channel is insufficient to display the data to the desired resolution. The typical solution has been to design a "wide chart" oscillographic recorder that offers full-scale deflections of 80 to 100 mm. This is an acceptable solution as long as requirements don't change and the recorder remains in that service for its lifetime. But if flexibility in channel width is needed, the entire pen-motor assembly and stylus must be changed to convert from conventional recording to wide chart or vice versa. This results in considerable expense and inconvenience.

The 7402A offers a convertible system that can be either two 50 mm channels or one 100 mm channel at the flip of a switch. The method doesn't involve a mechanical change, but a "time sharing" of the data by the two pens. The input signal is transmitted through the channel 1 preamplifier to both servo amplifiers. The two 50 mm channels operate in a class B mode, much as a solid-state audio amplifier, with a loss of only 2 mm of data down the center of the chart where the signal crosses over from one stylus to the other.

The wide channel operation is possible because of the separation of the position controls from the input amplifiers, the extremely sharp and stable electrical limiting used in the pen-motor servo amplifiers and the well controlled step response of the servo loop.

The 3 dB bandwidth in the 100 mm configuration is 48 Hz, and the risetime remains at 7 ms, as in the 50 mm case.

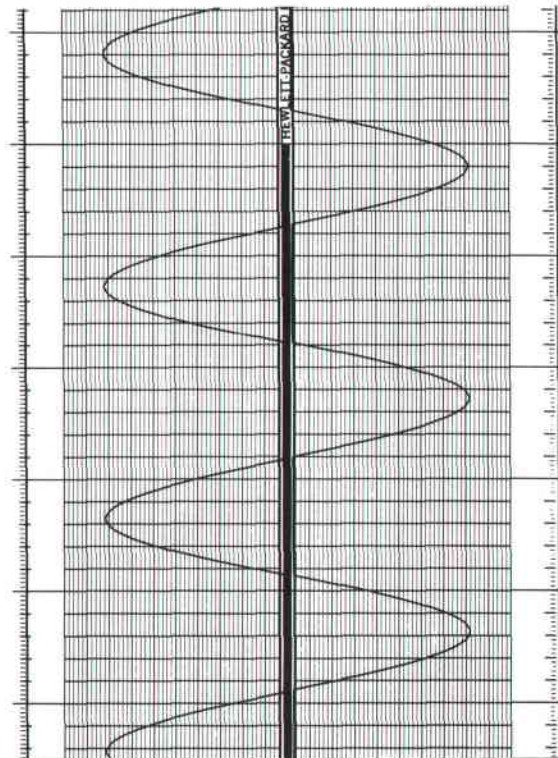

As mentioned earlier, the stainless-steel pen bodies have virtually eliminated stylus failures. Even so, there is a possibility of damage by a misdirected finger or screwdriver. Should a pen ever need replacement, the procedure is a simple one. The carbide-tipped pens are pre-lapped to the approximate contour of the paper platen. After a pen is replaced—this involves removing a single snap ring—final lapping is accomplished by taping a mylar strip over the chart paper and running the pen with a 15 Hz sinewave input and a chart speed of 5 mm per second. The mylar strip contains a fine abrasive and is furnished with the pen. No manual pen lapping is required.

Acknowledgments

The 7402A was a team effort that enlisted the cooperation of the fab shops, the model shop, production, marketing, and tooling.

In particular, the author wishes to thank those individuals who made outstanding contributions when they were most needed. Test technician Jerry Nevins and manufacturing engineer Gale Moreland worked closely with the engineering team through-

out the project. Project leader Ron Norton took over late in the project and made the pilot run a success. Jim Severine spent long hours with the Nyquist plots that led to the stability of the servo system. Ed Salter displayed great tenacity during the more difficult design phases of the transmission, paper drive, pen motors, and stylus. Howard Merrill made many contributions in the 17400A High Gain Preamplifier and event marker system. We owe the instant dry writing quality to ink designer and writing system consultant Dale Davis. Industrial designer Bart Davis, and product designer Don Hiler deserve special credit for the outstanding product design. I wish to extend my personal thanks to the management of the lab during the development cycle for giving total support to this product. 📄

References

1. W. R. McGrath and A. Miller, "Fine-Line Thermal Recording on Z-Fold Paper," Hewlett-Packard Journal, February 1972.
2. J. K. Vennard, "Elementary Fluid Mechanics," Wiley, 1961.
3. R. S. Hartenberg and J. Denavit, "Kinematic Synthesis of Linkages," McGraw-Hill, 1964, page 41.

APPENDIX

Dynamic Writing System Analysis

The following is an analysis of the fluid dynamics within the stylus, first investigated by Bernard M. Oliver, HP Vice President for Research and Development, and LeRoy Kapel. The analysis was a key factor in the development of a new writing concept for the 7402A Oscillographic Recorder.

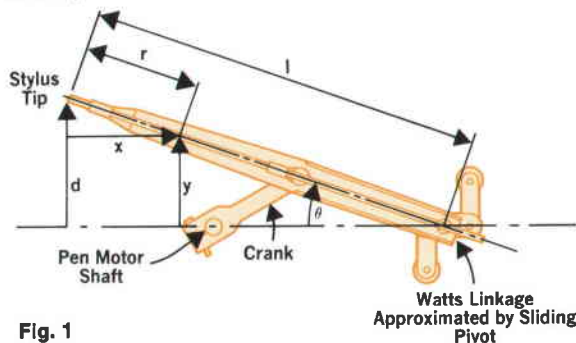

Fig. 1

Referring to Fig. 1, the linkage converts the rotary motion of the pen motor to a rectilinear movement at the stylus tip. Rectilinearity is achieved within ± 0.025 mm over the full-scale excursion of 50 mm. For all practical purposes, this is perfect linearity. For this analysis, it will be assumed that the tail pivot of the stylus is constrained to a linear fore-and-aft movement by the Watts linkage³.

For any point along the stylus tube a distance r from the tip,

$$x = r \cos \theta \quad (1)$$

$$\dot{x} = -r \dot{\theta} \sin \theta \quad (2)$$

$$\ddot{x} = -r(\ddot{\theta} \sin \theta + \dot{\theta}^2 \cos \theta) \quad (3)$$

$$y = d - r \sin \theta \quad (4)$$

$$\dot{y} = \dot{d} - r \dot{\theta} \cos \theta \quad (5)$$

$$\ddot{y} = \ddot{d} - r(\ddot{\theta} \cos \theta - \dot{\theta}^2 \sin \theta) \quad (6)$$

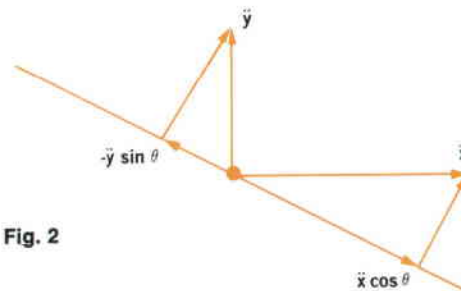

Fig. 2

The components of acceleration along the tube (Fig. 2) are:

$$\ddot{x} \cos \theta \quad (7)$$

$$-\ddot{y} \sin \theta \quad (8)$$

Substituting for x and y , the acceleration along the tube is:

$$a = -\ddot{d} \sin \theta - r \dot{\theta}^2 \quad (9)$$

The two terms have a simple interpretation. $\ddot{d} \sin \theta$ is the component of acceleration along the arm that would occur if the arm were purely translated in the y direction ($\theta = \text{constant}$), while $r \dot{\theta}^2$ is the centrifugal force which results from rotation of the stylus about the stylus tip as a center. The mean value of acceleration \bar{a} over the length of the stylus (l) is:

$$\bar{a} = \frac{1}{l} \int_0^l a(r) dr \quad (10)$$

$$= -\ddot{d} \sin \theta - \frac{l}{2} \dot{\theta}^2 \quad (11)$$

In terms of the given quantities:

$$\bar{a} = -\frac{\ddot{d}}{l} - \frac{l}{2} \frac{\dot{d}^2}{(l^2 - d^2)} \quad (12)$$

In the worst case, where $l = 10$ cm and $d = 2.5$ cm,

$$\bar{a} \approx -\frac{1}{l} (\ddot{d} + \frac{\dot{d}^2}{2}) \quad (13)$$

to within 6.25% and the error decreases as the square of the deflection, d ,

assuming that the pen tip traces a sinusoid,
 $d = d_1 \sin \omega t$ (14)

$\dot{d} = \omega d_1 \cos \omega t$ (15)

$\ddot{d} = -\omega^2 d_1 \sin \omega t$ (16)

Substituting and simplifying,

$\bar{a} = \frac{\omega^2 d_1^2}{4l} (1 - 3 \cos 2\omega t)$ (17)

Also, the mean pressure \bar{p} is:

$\bar{p} = \rho \bar{a}$

where ρ is the density of the fluid. For a fluid of specific gravity 1.0 the induced pressure (lbf/in²) is:

$\bar{p} = 2.33 \times 10^{-5} \omega^2 d_1^2 (1 - 3 \cos 2\omega t)$ (18)

The average pressure is a combination of a positive steady-state component and a sinusoidally fluctuating component at twice the pen tip frequency. Both components vary with the square of frequency and deflection. At $\omega = 250$ rad/sec (~40 Hz) and full scale deflection of ± 2.5 cm:

$\bar{p} = 1.456 - 4.37 \cos 2\omega t$ (19)

The fluctuating component is the one that has induced designers to employ means to vary the pressure or simply overcome the variation with a sufficiently high base pressure. Both of these methods have their drawbacks, one being complex, and the other having problems at low writing velocities. The latter has been somewhat overcome by use of high-viscosity ink, which results in wet writing at high velocities.

The 7402A approach was to take advantage of the increase in induced pressure, keep the viscosity low for dry writing at high velocity, and filter the fluctuating component.

For laminar flow of a fluid of viscosity μ through a tube of diameter D and length l ,

$p = \frac{128 \mu l}{\pi D^4} Q$ (20)

If we use dimensions of lbf/in² for p , inches for l and D , in³/s for Q , and poise for μ , we can combine constants to get

$p \text{ (lbf/in}^2\text{)} = \frac{5.9 \times 10^{-4} \mu \text{ (poise)} l \text{ (in)} Q \text{ (in}^3\text{/s)}}{D^4 \text{ (in}^4\text{)}} \text{ (21)}$

Now we can define a fluid resistance term R_p analogous to an electrical resistance

$R_p = \frac{p}{Q} = \frac{5.9 \times 10^{-4} \mu}{D^4} \text{ (22)}$

$= 3.687 \times 10^3 \frac{\text{lbf-s}}{\text{in}^5} \text{ (23)}$

for $\mu = 0.2$ poise, $l = 5$ inches, and $D = .02$ inches.

The supply tube resistance is:

$R_t = \frac{(5.9 \times 10^{-4}) (.2) (4)}{(.029)^4} \text{ (24)}$

$R_t = 670 \frac{\text{lbf-s}}{\text{in}^5} \text{ (25)}$

The filter capacitor is the rubber accumulator boot close to the pen tip. (See Fig. 6, page 13). The value of this fluid capacitor was measured by applying various pressures to the tube and measuring the variation in the accumulator profile with an optical comparator. The capacitance was then calculated as:

$C_r = \frac{dv}{dp} = \frac{\text{change in volume (in}^3\text{)}}{\text{change in pressure (lbf/in}^2\text{)}} \text{ (26)}$

$C_r = 3 \times 10^{-6} \frac{\text{in}^3}{\text{lbf}} \text{ (27)}$

The tip-paper interface resistance was calculated from flow measurements at high velocity (300 in/sec peak) and was found to be:

$\text{Flow Rate} = 4 \times 10^{-5} \text{ in}^3/\text{s} \text{ (28)}$

$R_i = \frac{5.4^*}{4 \times 10^{-5}} = 1.32 \times 10^5 \frac{\text{lbf-s}}{\text{in}^5} \text{ (29)}$

The induced pressure is distributed along the pen tube, but is distributed in series with the fluid resistance. Thus, we have a simple series circuit for the model, as shown in Fig. 3.

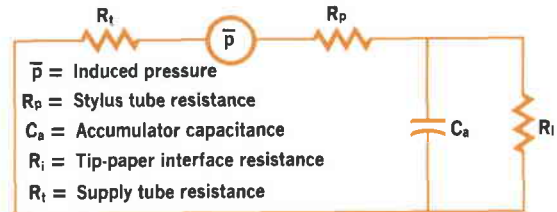

Fig. 3

From (18), the steady state pressure is:

$\bar{p}_{st} = 2.33 \times 10^{-5} \omega^2 d^2 \text{ (30)}$

The induced pressure variations at the pen tip, as a function of the pen tip frequency are:

$\bar{p}_v = 2.33 \times 10^{-5} \omega^2 d^2 \frac{3}{j2\omega C_a (R_i + R_p) + 1} \text{ (31)}$

Note that the frequency applied to the filter is twice that of the pen tip frequency ($j2\omega$).

A plot of (30) and the summation of (30) and (31) is shown in Fig. 4.

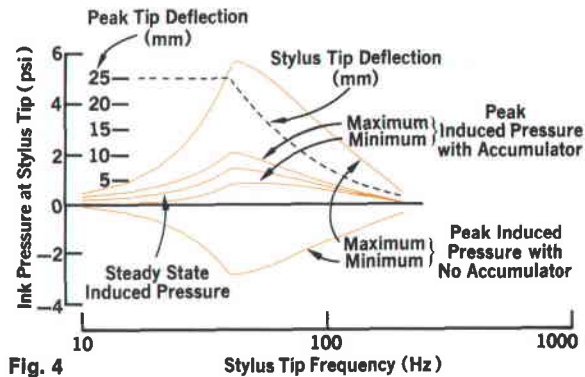

Fig. 4

The peak amplitudes of the sinusoidally varying induced pressure are plotted, both with and without the accumulator boot (filter) at the stylus tip.

At 42Hz, the steady-state induced pressure is +1.45 psi. The negative peak variation with no accumulator would be 4.3 psi, resulting in a net pressure of -2.85 psi. This negative peak is attenuated to .6 psi by the accumulator, resulting in a net pressure of +.85 psi. Thus, the net difference in externally applied base pressure to achieve equal writing quality for each case would be 3.7 psi.

To verify the prediction, the accumulator was defeated by slipping a tight fitting teflon tube over the accumulator hole in place of the rubber boot. Writing performance tests were run and the results revealed that worst-case writing occurred at about 55 Hz, and the base pressure required to write at this frequency with the accumulator was 3 psi, and without the accumulator, 6 psi.

The predicted pressure difference as taken from the graph at 55 Hz is 3.5 psi, indicating good correlation between predicted and measured results, and confidence in the first-order model used for analysis.

Further refinements in the model could be made by including the flow of ink in and out of the accumulator, variable interface resistance due to change in flow rate with frequency, and compliance in the supply tubing. These second-order effects could explain the actual worst-case writing frequency of 55 Hz versus the predicted frequency of about 42 Hz. It must be remembered, also, that "acceptable writing" is defined as a full pen-tip-width trace, with no feathering of the edges. At pressure considerably lower than the 3 and 6 psi measured in the tests, the pen was still delivering a trace to the paper, albeit a somewhat ragged one.

The results of this analysis allowed the designers to use a factor-of-two lower base pressure, which in turn permitted a significant improvement in low-speed writing.

* 4 psi externally supplied base pressure, 1.4 psi induced pressure

SPECIFICATIONS

HP Model 7402A Oscillographic Recorder

	With 17400A	With 17401A	With 17402A
INPUT RANGES	1, 2, 5, 10, 20, 50, 100, 200, 500 μ V/div; 1, 2, 5, 10, 20, 50, 100, 200, 500 mV/div; 1, 2, 5 V/div. Continuous vernier between ranges.	1, 2, 5, 10, 20, 50, 100, 200, 500 mV/div; 2, 5 V/div. Continuous vernier between ranges.	20, 50, 100, 200, 500 mV/div. Continuous vernier between ranges.
TYPE OF INPUT	Differential, floated, and guarded. Inputs thru rear connector.	Balanced to ground. Inputs thru rear connector.	Single ended. Inputs thru rear or front connectors.
MAXIMUM ALLOWABLE INPUT (Continuous)	500 Vdc on 10 mV/div range & above; other ranges, 120 Vdc or 120 Vac rms (500 V peak).	230 V rms on 500 mV/div range & above; other ranges 120 V rms.	230 V rms on 200 mV/div range & above; other ranges 120 V rms.
INPUT RESISTANCE	1 M Ω (min.)	500 k Ω each side to ground.	1 M Ω
COMMON MODE REJECTION	dc 150 dB; 90 dB on 10 mV/div and above. ac 140 dB; 80 dB on 10 mV/div and above. (1 k Ω source unbal)	>50 dB >50 dB (100 ohm source unbal)	
MAX ALLOWABLE COMMON MODE VOLTAGE	200 Vdc or peak ac.	250 Vdc or peak ac on 500 mV/div and above; other ranges 15 Vdc or peak ac.	
FREQUENCY RESPONSE	50 div +0%, -6% of full scale from dc to 40 Hz at 5 μ V/div and above; 28 Hz at 2 μ V/div; 15 Hz at 1 μ V/div. 10 div -3 dB at 125 Hz at 5 μ V/div and above; 80 Hz at 2 μ V/div; 45 Hz at 1 μ V/div.	\pm 2% of full scale from dc to 40 Hz. -3 dB at 140 Hz.	\pm 2% of full scale from dc to 40 Hz. -3 dB at 140 Hz.
RISE TIME (Typical, 10% to 90% of 50 mm deflection)	7.5 ms	7 ms	7 ms

OVERSHOOT	<2%	<2%	<2%
ACCURACY	\pm 0.75% of full scale \pm 0.06%/°C	\pm 0.75% of full scale \pm 0.06%/°C	\pm 0.75% of full scale \pm 0.06%/°C
LINEARITY	\pm 0.6% of full scale.	\pm 0.6% of full scale.	\pm 0.6% of full scale.
ZERO	Adjustable to 30 mm either side of grid center. Position stability \pm 0.1 mm/°C.		
ZERO SUPPRESSION	1, 10, 100 V on 10 mV/div range & above; other ranges 1, 10, 100 mV. Continuous calibrated vernier between suppression steps.	(OPTIONAL) 0.2, 2, 20 V, vernier between suppression steps.	
ZERO SUPPRESSION ACCURACY	\pm 0.5% of suppression \pm 0.5% of full scale.	\pm 0.5% of suppression \pm 0.5% of full scale.	
	\pm 0.02%/°C.	\pm 0.02%/°C.	
CHART SPEEDS	1, 5, 25, 125 mm/s. Front panel or remote selection, including STOP, via contact closure or TTL level.		
CHART SPEED ACCURACY	\pm 0.5% plus power line frequency variation from 60 Hz (50 Hz with Option 004).		
CHART WEAVE	\pm 0.25 mm	\pm 0.25 mm	\pm 0.25 mm
ENVIRONMENT (Operating)	0°C to 55°C and <95% relative humidity from 25°C to 40°C.		
PRICES IN U.S.A.:	7402A Mainframe (less plug-ins)		\$1450
	17400A High-Gain Preamplifier		675
	17401A Medium-Gain Preamplifier		225
	17401A with Zero Suppression (Option 001)		350
	17402A Low-Gain Preamplifier		145
	OPTIONS		
	001 Event Marker (left hand)		\$ 65
	002 Event Marker & Timer (right hand)		100
	003 Both Event Marker & Event Marker/Timer		160
	004 50 Hz Power Line Operation		N/C
	005 Paper Take-Up (external)		110
	006 Rack Mount Adapter		50
	SUPPLIES/ACCESSORIES		
	Description	HP Part Number	
	Paper Take-Up:	07402-60022	\$ 110
	Rack Mount Adapter:	07402-60023	50
	Paper: 275 ft (84 m) roll:	9280-0258	5

MANUFACTURING DIVISION: SAN DIEGO DIVISION
16399 West Bernardo Drive
San Diego, California 92127

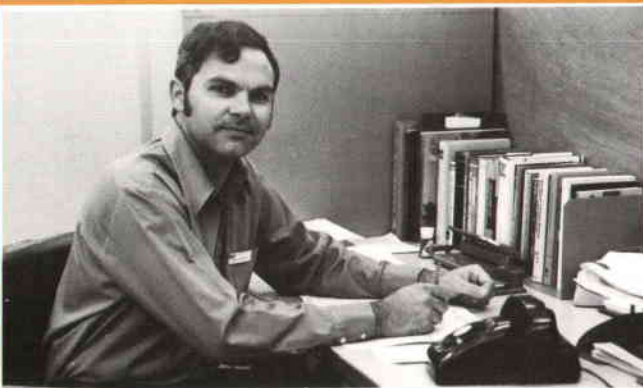

Lawrence Brunetti

Larry Brunetti is section manager for oscillographs, card readers, and tape recorders at HP's San Diego Division. He was project leader for the 7402A Recorder. Larry received his BSEE degree in 1959 from the University of Nevada at Reno and his MSEE in 1964 from the University of California at Berkeley. He came to HP in 1969. Away from the job, Larry has worked with local high school classes to show the relevance of mathematics to industry. His recreational interests include model railroading, guitar, drawing, and cycling, which he supports by serving on two local bikeways planning committees.

A Quiet, Low-Cost, High-Speed Line Printer

This thermal printer writes 80 column lines at 250 lines per minute. Developed primarily for the 9830A Calculator, it's a general-purpose printer that's easily interfaced to a variety of controllers.

by Dick B. Barney and James R. Drehle

AT THE BEGINNING of the development of the BASIC-Language Model 9830A Calculator¹, an investigation was launched to find a companion printer. To satisfy most of the anticipated applications of the 9830A Calculator, it was desirable for the printer to be high-speed, yet quiet enough for an office environment. Also, the cost had to be low enough for a calculator system. This early investigation revealed that these objectives could best be met by development of a high-speed line printer designed specifically for the 9830A Calculator.

Model 9866A Printer, shown in Fig. 1 with the 9830A Calculator, is the result of this development effort. Model 9866A is a low-cost, high-speed thermal line printer. The printer writes 80 characters per line and comes with a 64-ASCII-character font. A typical BASIC program listing by the 9866A Printer is shown in Fig. 2.

The printing speed is 250 lines per minute, which compares favorably with many of the computer-oriented line printers costing much more. The printer can advance paper under program control at three inches per second for paging operations.



Fig. 1. Model 9866A Printer, shown here with 9830A Calculator, was designed for the 9830A system, but can be used with many controllers. It prints 80-column lines at 250 lines per minute.

EACH X = 0.50 PERCENT

```
0.0000 . *
. *
1.0000 . *
. XXXXXXXXXXXXXXXXXX*XXXX
2.0000 . *
. XXXXXXXXXXXXXXXXXXXXXXXXXX*XXXXX
3.0000 . *
. XXXXXXXXXXXXXXXXXXXXXXXXXXXXXXXXXX*XXXXXXXXXXXX
4.0000 . *
. XXXXXXXXXXXXXXXXXXXXXXXXXXXXXXXXXX*
5.0000 . *
. XXXXXXXXXXXXXXXXXXXXXXXXXXXXXXXXXX* *
6.0000 . *
. XXXXXXXXXXXXXXXXXXXXXXXXXXXXXXXXXX* *
7.0000 . *
. XXXXXXXXXX *
8.0000 . *
. XXXXXXXXXXXXXXXXXXXXXXXXXX*
9.0000 . *
. XXXXXXXXXXXXXXXXXXXXXXXXXX*
10.0000 . *
```

BASIC STATISTICS

```
10 M=S1/N
20 S=SQR((S2-M*M*N)/(N-1))
30 M3=S3/N-3*M*S2/N+2*M^3
40 M4=S4/N-4*M*S3/N+6*(M^2)*S2/N
50 M4=M4-3*M^4
60 FORMAT F12.4,/,F12.4,/,F12.4,/,F12.4
65 PRINT
70 PRINT "N="N
80 WRITE (15,60)"MEAN="M,"STD. DEV="S,"SKEWNESS="M3/S^3,"KURTOSIS="M4/S^4
111 IF T1=0 THEN 120
112 PRINT "MIN,MAX,RANGE MAY BE INCORRECT"
120 WRITE (15,60)"XMIN="R1,"XMAX="R2,"RANGE="R2-R1
150 IF R3=0 THEN 170
160 PRINT "NO. TOO SMALL="R3
170 IF R4=0 THEN 190
180 PRINT "NO. TOO LARGE="R4
190 FOR J=1 TO 10
200 PRINT
210 NEXT J
220 END
```

Fig. 2. Typical 9866A printout. Character font includes 64 ASCII characters.

The thermal printing technology used in the 9866A is basically the same as that of the 16-column strip printer for the 9810A and 9820A Calculators.² However, increasing the line length from 16 to 80 characters made it necessary to develop a new thermal printhead for the 9866A. Development of this printhead is described in the box on page 23.

Efficient Paper Handling

Loading the supply of printing paper into many printers can be a difficult and time-consuming operation. Therefore, one of the objectives in the design of the 9866A Printer was an efficient paper handling system.

The solution to the paper handling problem in the 9866A is a self-loading mechanism. This mechanism consists of a storage bin for a roll of 250 feet of paper, located in the center of the printer, and a set of rollers and guides for taking the paper off the roll and placing it between the printheads and the platen. Fig. 3 illustrates the self-loading mechanism.

A diagram on the underside of the storage bin cover shows the proper orientation of the paper roll

in the bin. Once the paper has been properly placed in the storage bin, the operator simply closes the cover and pushes the PAPER button on the front cover. In a few seconds, the paper will appear and the printer is ready to use.

Paper tracking is a constant problem in paper handling systems. In the 9866A Printer, reference edges in the paper bin at each end of the paper roll were added to prevent excessive shifting of the paper roll. This also helps control margin width. Also, the paper feed roller is smaller in diameter than the platen or pinch roller, and this causes back tension in the paper web, which improves paper tracking. Another principle which improves paper feeding as well as tracking is variable pressure of the pinch roller against the platen, depending upon the roll size.

The platen is driven directly from a stepping motor. This eliminates the slip, stretch and backlash common in most indirect drive systems. The direct drive system yields more accurate line spacing and improved print quality.

The platen material was designed specifically for this application. The material was selected to opti-

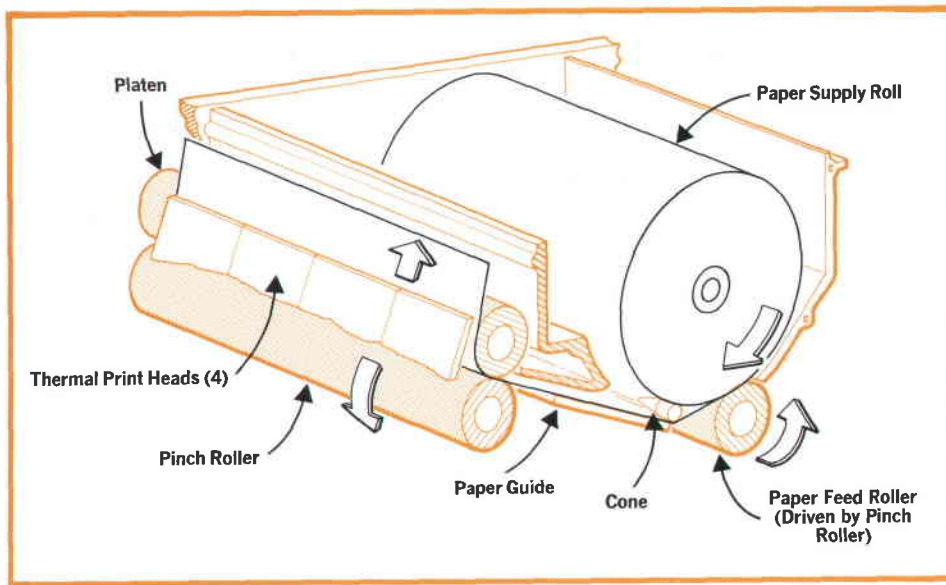

Fig. 3. To reload paper in Model 9866A Printer, the user simply drops in a new roll and this self-loading mechanism does the rest.

mize print quality, minimize platen-to-printhead friction, and minimize aging problems and cracks caused from ozone in the atmosphere. Also, under normal print voltage, the platen is not damaged if the user should inadvertently print on the platen with no paper under the printheads.

Simple Interface

The interface between the controller and the 9866A Printer consists of 12 lines. The line assignments are shown in Table I. Seven of these lines

Table I: 9866A Line Assignments

Line	Name	Mnemonic
1	Data Input 1	DI1
⋮	⋮	⋮
7	Data Input 7	DI7
8	Command	CMD
9	Flag	FLG
10	Out-of-Paper	OTP
11	Clear Line Buffer	CLB
12	Common	GND

(DI1 through DI7) are used for data input in the form of 7-bit ASCII codes.

The 7-bit ASCII character codes are transferred from the controller to the printer under the control of the CMD and FLG lines. These lines operate in a "handshake" sequence. Thus the transfer of characters between the controller and printer can be asynchronous and the printer can respond to controllers with different output speeds.

The printer indicates that it is ready to accept characters by letting the FLG line go to a high level (logical "0"). The controller indicates that a character is on the data input lines by taking the CMD line low. If the FLG line is not high, the controller

cannot take the CMD line low. After the CMD line goes low, the printer indicates that the character has been accepted by setting the FLG line low. The FLG line will remain low until the printer is finished processing the input character and the controller returns the CMD line high. When the printer sets the FLG line back to a high level, the handshake sequence can be repeated for the next character.

OTP and CLB are status lines which the controller can use to monitor and control the printer status. The low state of the OTP line indicates that the printer is out of paper. When the printer is in this state, it will not accept any characters. This condition must be cleared before the controller can transfer any characters into the printer's line buffer.

The CLB line can be set low by the controller to clear the line buffer in the printer. This operation will cause the printer to ignore any characters that have been transferred from the controller since the last LF (line feed) ASCII character.

Printer Configuration

Fig. 4 is a block diagram of the 9866A Printer, showing the interconnections between the major electronic, thermal, and electromechanical modules. The control logic monitors the status of the printer and issues instructions to the other modules in response to commands from the controller. The control logic has two modes of operation, a character-receiving mode and a print cycle mode.

In the character-receiving mode of operation, 7-bit ASCII characters from the controller are entered into a latch where they are decoded. The printer will acknowledge all the 128 7-bit ASCII codes. The decoder sorts the 7-bit ASCII codes into two groups, character codes and control codes. The

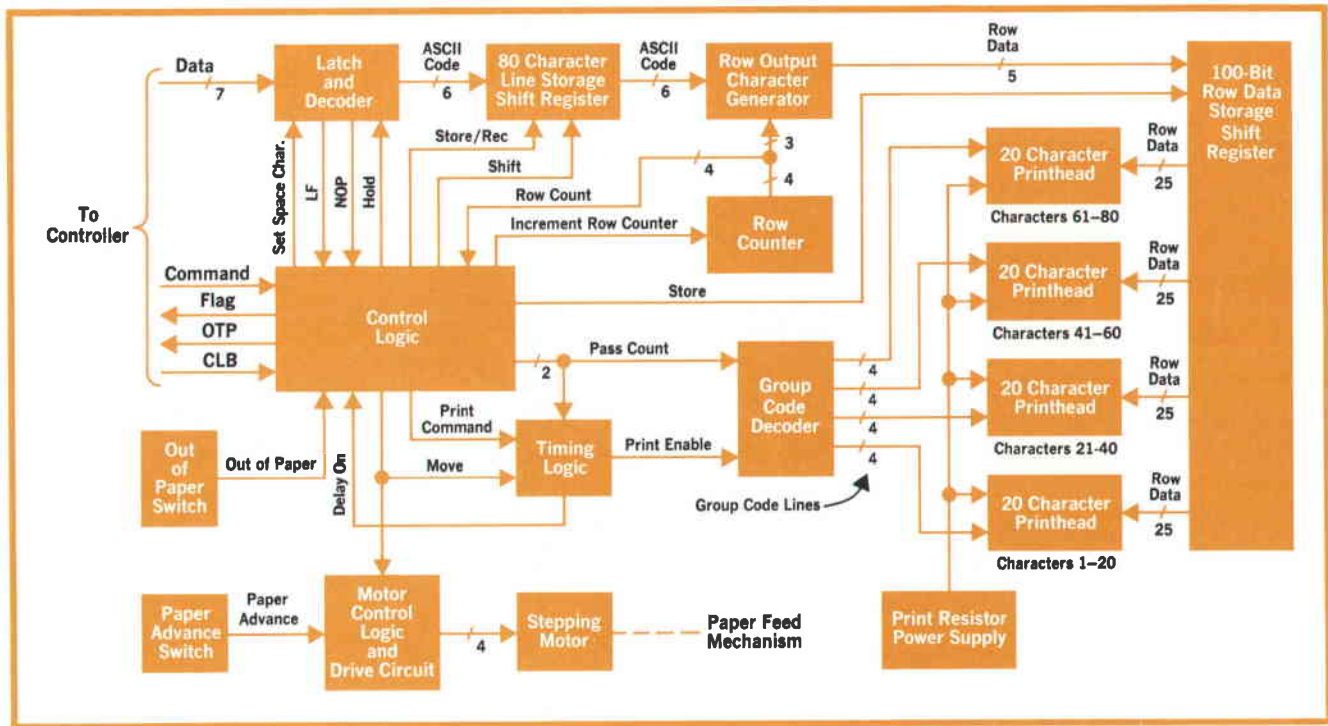

Fig. 4. Control logic monitors printer status and issues instructions to other modules in response to commands from the controller.

printer recognizes the standard 64 character codes plus the codes reserved for lower-case alpha characters as codes which represent characters to be printed. The lower-case alpha characters are printed as their upper-case counterparts.

The character codes are stored in the line storage shift register. All control characters with exception of the LF (line feed) code are ignored by the printer. The LF code serves as a line terminator code.

The print cycle starts when an LF character is received from the controller. During the print cycle, the control logic operates on the character codes stored in the line storage shift register to produce a 5 x 7 dot-matrix replica of each character in the line. The characters in the 80-column line are printed on a row by row basis, that is, the top row of all 80 characters is printed, then the paper is stepped to the next row, and so on.

The interconnections between the electronic modules and the four thermal printheads used in forming the rows of the 5 x 7 dot matrix characters are shown in the block diagram. Each printhead contains a row of 100 thick-film resistors spaced in groups of five to form the 5-dot rows of 20 characters.

The Writing Process

The algorithm used by the printer for receiving, analyzing, storing and printing a line of characters

is described by the simplified flow chart, Fig. 5. The upper section of the chart shows the character-receiving mode of operation and the lower section shows the print cycle.

In the character-receiving mode, besides receiving, analyzing, and storing ASCII characters, the printer also counts the number of characters received since the last LF code. If the input line length exceeds 80 characters, only the first eighty will be printed when the next LF code is received.

During the print cycle the line of 80 5 x 7 dot-matrix characters is formed one row of dots at a time. Each of the seven rows in the line of 5 x 7 dot-matrix characters is printed in four passes (20 characters per pass). This is required because of the high current demands of the print resistors (approximately 102 mA per resistor). It is possible on a 20-character pass to have all 100 print resistors turned on and demand more than 10 amperes from the print resistor power supply.

The 20 characters printed per pass are divided into five characters per printhead. The flow chart illustrates how the row data for every fourth character is stored in the row data storage shift register until 20 characters have been decoded. The row data for these characters is then printed and the row data generation process continues until the row data for each character in the line has been printed. The paper is then advanced to the next row in the 5 x 7 dot-matrix.

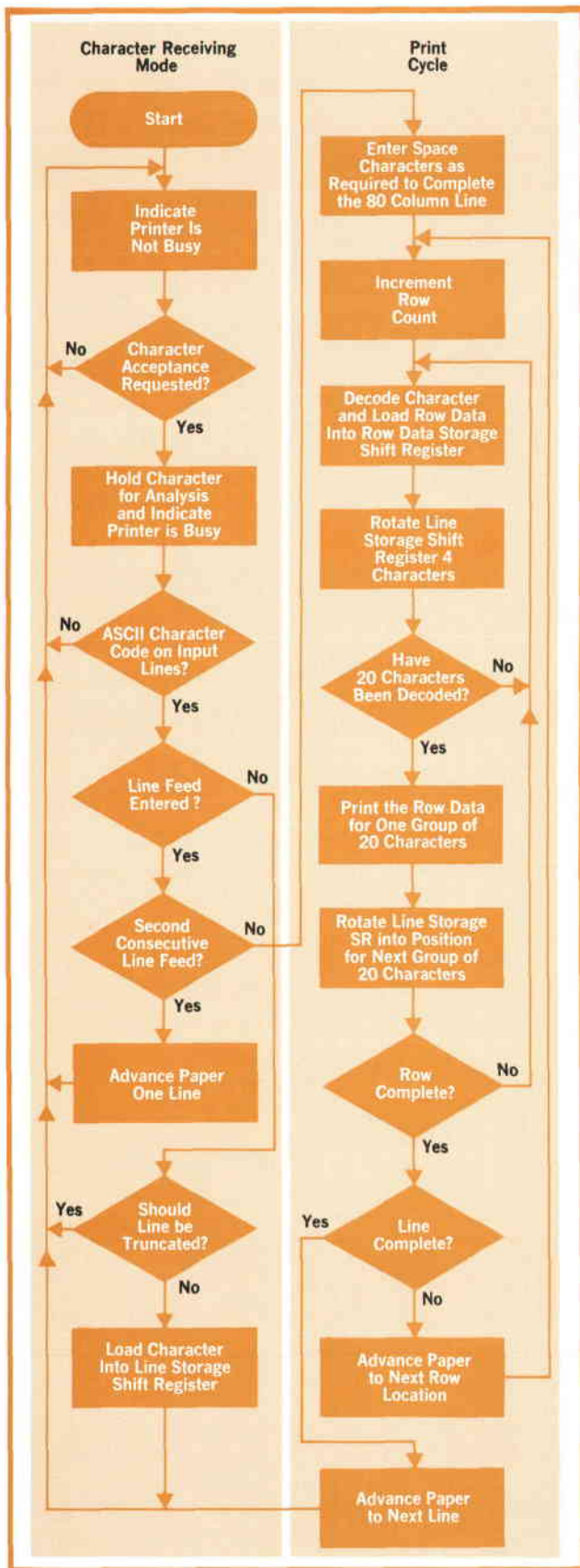

Fig. 5. Characters are formed from 5 x 7 dot matrices. Each of the 7 rows is printed in four passes (20 characters per pass). This is the algorithm.

The row formation process is repeated until all seven rows have been printed. Upon completion of the seventh row in the 5 x 7 dot-matrix, the paper is advanced to the next line location and the printer indicates to the controller that the printing process has been completed by returning the FLG line to a high level.

Acknowledgments

The design team for the 9866A Printer included: Russ Sparks, group leader; Leo Miller, power supplies; Ray Cozzens, Bob McMillan, and Fred Wullschleger, mechanical design; Arnold Joslin, industrial design. Bill Thayer also made significant contributions to the project. Gale Hamelwright served as group leader during the early investigation stage.

The hybrid printhead development team included Al Antes and Jim Walker of the Colorado Springs Division thick-film facility and Bill Thomas of the Loveland Division IC facility.

The authors would also like to thank Ray Cozzens and Bob McMillan for their contributions to this article.

References

1. R. M. Spangler, "BASIC-Language Model 30 Can Be Calculator, Computer, or Terminal," Hewlett-Packard Journal, December 1972, page 14.
2. "Printer and Keyboard for Models 10 and 20," Hewlett-Packard Journal, December 1972, page 11.

SPECIFICATIONS HP Model 9866A Printer

TEMPERATURE: 0°C–45°C
POWER: 100 V +5%, -10%
 120 V +5%, -10% } selected by
 220 V +5%, -10% } switch settings
 240 V +5%, -10% }
 50–60 Hz, 250 VA maximum

PRINTING TECHNIQUE: Thermal, 5 x 7 dot matrix
SPEED: 250 lines/min
LINE LENGTH: 80 characters
WEIGHT: 40 lbs (18,14 kg)
SHIPPING WEIGHT: 54.6 lbs (24,77 kg)
DIMENSIONS: 6.1" (15,49 cm) high
 17.75" (45,09 cm) wide
 16.1" (40,90 cm) deep

OPTIONAL INTERFACES:
 For Model 30 Calculator, 9866A Opt. 30
 For Model 20 Calculator, 9866A Opt. 20
 For Model 10 Calculator, 9866A Opt. 10
 With other controllers use standard 9866A

PRICE IN U.S.A.: \$2975.00
MANUFACTURING DIVISION: CALCULATOR PRODUCTS DIVISION
 815 Fourteenth Street S.W.
 Loveland, Colorado 80537

The Thermal Printhead Story

The problem of designing a thermal printhead for the 9866A Printer was primarily one of miniaturization. The basic technology had already been successfully used in the 16-column strip printer for the 9810A and 9820A Calculators, and the mechanical simplicity of this strip printer made it attractive to use the same printing technique for the 80-column line printer.

To achieve the required speed of greater than four lines per second a different drive scheme had to be developed for the line printer, but it is still a mechanically simple one (see the accompanying article). On the other hand, extending the printhead capacity from 16 to 80 columns proved more difficult.

Each of the characters in the 16-column strip-printer line is formed from a 5 x 7 dot matrix. A line of print is produced by printing the top row of dots for all 16 characters and then moving the paper to the next dot row. After completing the seventh row of dots, three blank rows are added to form the space between lines.

To produce each row of dots, 16 groups of five thick-film resistors are arranged across the top edge of a 2½ by 1¼ inch ceramic substrate. A dot is produced by sending current through one of these resistors, heating it enough to affect the heat-sensitive paper.

The large size of the 16-column substrate was necessary to accommodate the gold pattern needed to interconnect the printhead and the electronics and to allow enough space to fan out the gold leads. There are 88 interconnections between the electronics and the thermal printhead. The 88 leads on the printhead are arranged along the bottom of the ceramic substrate. There are 80 0.015 inch gold traces on 0.025 inch centers for the resistor leads and eight 0.040 inch gold traces for group leads.

If this same arrangement were to be used in the 80-column 9866A Printer, 440 interconnections would be required between the printhead and the electronics, and the ceramic substrate of the printhead would have to be 12 inches wide. Thick-film technology can't handle such a large substrate, so a different approach had to be taken.

To reduce the size of the substrate and decrease the number of interconnections required, a hybrid thermal printhead was designed. The hybrid printhead contains 20 groups of five resistors and prints 20 characters. On the ceramic substrate are five bipolar integrated-circuit decoder/driver chips (see Fig. 1). Four of the hybrid printheads are used in each 9866A Printer.

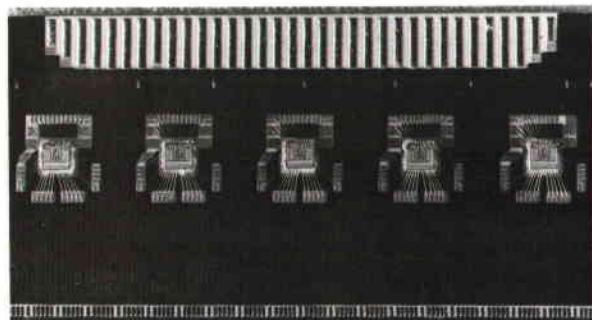

Fig. 1. To reduce size of substrate and number of interconnections, bipolar decoder/driver circuits are mounted on Model 9866A printhead substrate.

Each thick-film resistor must be driven individually and isolated from other resistors in its own group or in other groups. Isolation can be assured by providing an individual transistor driver for each resistor or by diode isolation if common drivers are used. Individual transistor drive was the method selected, because it decreased the conductor complexity on the substrate.

To heat one resistor to the 200°C needed to print at four lines per second takes approximately 1.9 watts. The thick film resistors have an average resistance of 180 ohms, so each driver transistor is required to sink 102 milliamperes. The size of a transistor able to sink this much current, along with the size of the bonding pads, limits the number of resistors that can be driven by an individual chip. Each bipolar chip is designed to drive 20 individual resistors—four groups of five resistors—to form four characters. Hence five chips are needed per 20-character substrate.

To reduce the power dissipated in individual chips and in the resistors, printing is done in four cycles, every fourth group of resistors being heated on a given cycle. Thus the peak power required to heat the resistors is reduced from nearly 800 watts for all 400 resistors to less than 200 watts. Also, the power dissipated in each transistor driver averages about 200 mW but can go as high as 350 mW. By using only one-quarter of the chip at a time, the peak power ranges between 1 W and 1.75 W, low enough to keep the surface temperature of the chip below 200°C.

The bipolar chip is essentially a five-to-twenty line demultiplexer/driver. Five input lines select the individual resistors within a character and four group lines determine which of the four characters controlled by the chip is to be printed.

Use of the bipolar chips reduces the size of the printhead substrate to 2 x 1 inches and reduces the number of interconnections from 110 per printhead to 34. Of the 34 connections, 29 are logic input signals for selection of individual print resistors, one carries +5 volts for decoder/driver chip power, two supply power to the print resistors, and two are ground. The 34 interconnections are spaced on 0.050 inch centers along the bottom of the substrate and are coated with solder. A flexible cable and connector are reflow soldered to the substrate, and a plastic stress-relief clamp is used to provide mechanical strength for handling. Fig. 2 shows the completed printhead.

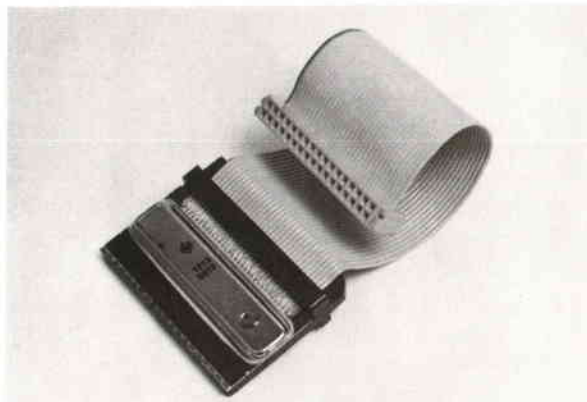

Fig. 2. Completed 20-column printhead for Model 9866A Printer.



Dick B. Barney

Dick Barney designed most of the electronics in the 9866A Printer. Dick holds BSEE and MSEE degrees from Montana State University, received in 1965 and 1969. Between degrees, he worked for an oil company and a power company. He came to HP in 1969 and helped design the I/O system for 9800-Series Calculators before taking on the printer. In his pre-college days Dick served three years in the U.S. Navy. He's a member of IEEE and the current president of the local Toastmasters Club.



James R. Drehle

Jim Drehle received his BS degree in electrical engineering from Colorado State University in 1967 and his MS degree, also from CSU, in 1969, the same year he joined HP. After his first projects, a pair of interface-card designs, he served as project leader for the 2575A Coupler/Controller and the 11219A Printer, and most recently headed the printhead development project for the 9866A Printer. He's a member of IEEE, a flying enthusiast (temporarily grounded by an expired license), and a coin collector.

Hewlett-Packard Company, 1501 Page Mill Road, Palo Alto, California 94304

Bulk Rate
U.S. Postage
Paid
Hewlett-Packard
Company

HEWLETT-PACKARD JOURNAL

MAY 1973 Volume 24 • Number 9

Technical Information from the Laboratories of
Hewlett-Packard Company

Hewlett-Packard S.A., CH-1217 Meyrin 2
Geneva, Switzerland
Yokagawa-Hewlett-Packard Ltd., Shibuya-Ku
Tokyo 151 Japan

Editorial Director • Howard L. Roberts
Managing Editor • Richard P. Dolan
Contributing Editors • Ross H. Snyder,
Laurence D. Shergalis

Art Director, Photographer • Arvid A. Danielson
Art Assistant • Erica R. Helstrom
Administrative Services • Anne S. LoPresti
European Production Manager • Kurt Hungerbühler

CHANGE OF ADDRESS: To change your address or delete your name from our mailing list please send us your old address label (it peels off). Send changes to Hewlett-Packard Journal, 1501 Page Mill Road, Palo Alto, California 94304 U.S.A. Allow 60 days.

HP Archive

This vintage Hewlett-Packard document was
preserved and distributed by

www.hparchive.com

Please visit us on the web!

On-line curator: John Miles, KE5FX

jmiles@pop.net

