

MARCH 1973

HEWLETT-PACKARD JOURNAL

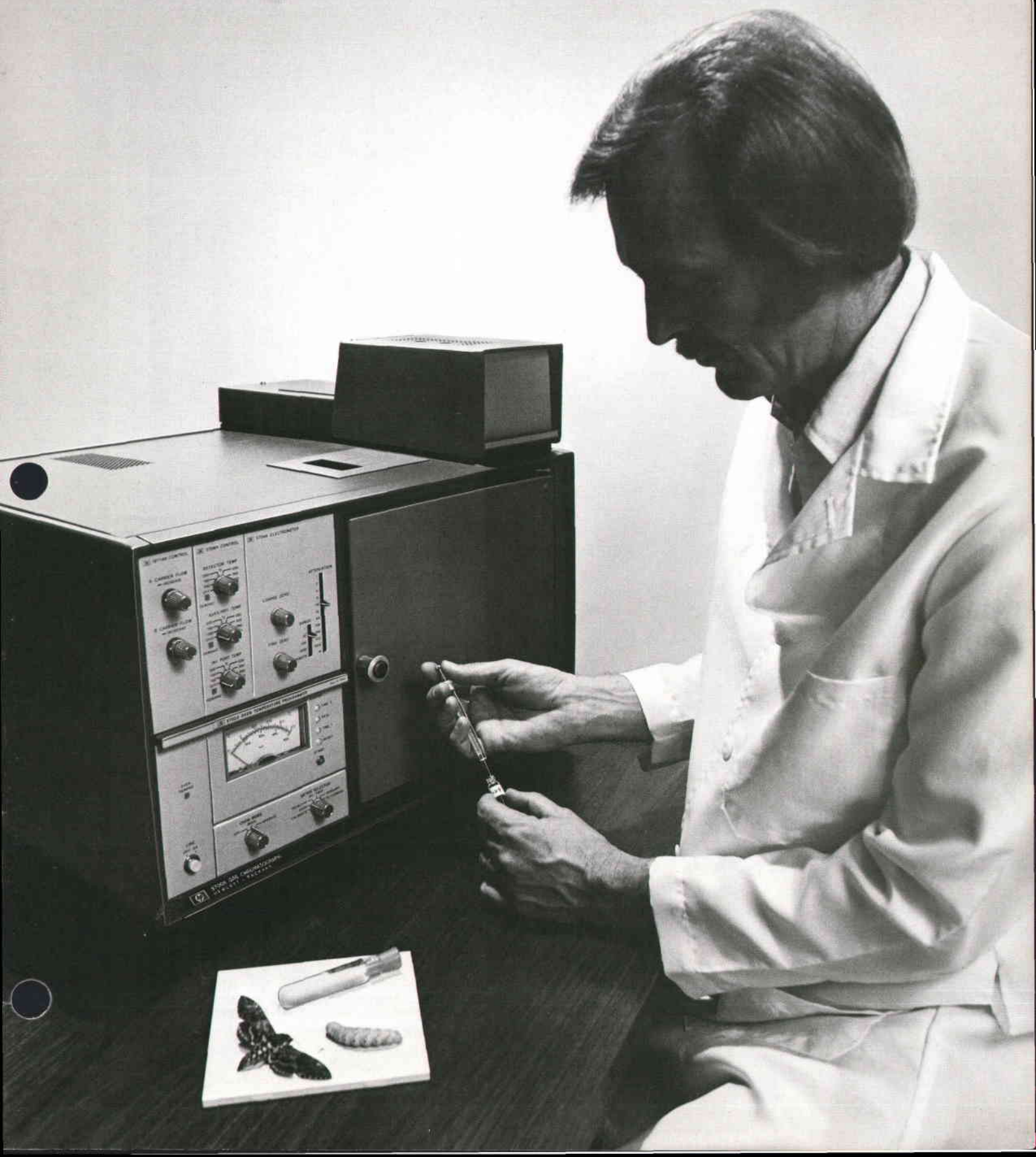

High Performance Flame-Ionization Detector System for Gas Chromatography

A new electrometer circuit plus improvements in mechanical design bring a higher level of performance to a widely-used technique for chemical analysis.

By Douglas H. Smith

THE FLAME IONIZATION DETECTOR, or FID, has become the most widely used detector for gas chromatography, primarily because of its high sensitivity to organic compounds. A new FID, incorporating several improvements over earlier designs, has been developed for the new Hewlett-Packard 5700A series Gas Chromatographs. This new design achieves a significant improvement in performance.

The earliest FID's used a battery in series with the electrometer input to provide the polarizing voltage for ion collection. The battery, however, had to supply a potential of 300 volts or so, and problems from shelf life and noise from the mounting insulators were commonly encountered.

Improved performance was obtained in later models by connecting the collector directly to the electrometer input, and applying the polarizing voltage to the jet. However, with this arrangement other grounded parts may attract ions in competition with the collector, limiting the linear portion of the dynamic range. Then, too, this arrangement requires an insulator for the jet, an insulator that can repeatedly withstand temperatures up to 400°C. Use of the insulator complicates cleaning, especially with regard to the high-voltage connection to the jet, and accurate spacing of the parts during re-assembly has been a problem.

The Benefit of Experience

The new 5700A-series FID reverts to the grounded jet but it uses a floating power supply for the polarizing voltage.

A cross-section of the new detector is shown in Fig. 1. Hydrogen gas is mixed with the sample as it leaves the column and the mixture is burned in air at the tip of the jet. Ions generated by the heat are

attracted to the collector and the resulting current is used as the input to an electrometer.

The jet body is in one piece that is easily removed for cleaning or replacement. The construction fixes the spacing between jet and collector accurately so that no adjustments are required for normal cleaning in the field, as has been required with other types.



Cover: *The instrument is the HP Model 5700A Gas Chromatograph. The insects are two versions of *Manduca Sexta*, an agricultural pest well-known to tomato growers as the tobacco hornworm. Gas chromatographs are well-nigh indispensable in the identification of pheromone structures and insect-generated hormone substances that are leading to more environmentally-acceptable ways of controlling insect pests like this. Our thanks to Zoecon Corporation for the loan of both *Manduca Sexta*, raised in-house for research on ways of identifying and synthesizing hormone- and pheromone-like agents.*

In this issue:

High Performance Flame-Ionization Detector System for Gas Chromatography, by Douglas H. Smith **page 2**

Synthesized Signal Generation to 1.3 GHz, by Roland Hassun, Melvin Humpherys, Dieter Scherer, Young Dae Kim, Bradley Stribling, and Charles Cook **page 11**

A Greater Range of Capabilities for the Compact, Plug-on Digital Multimeter, by Reid Gardner, Arthur Dumont, and Stephen Venzke **page 20**

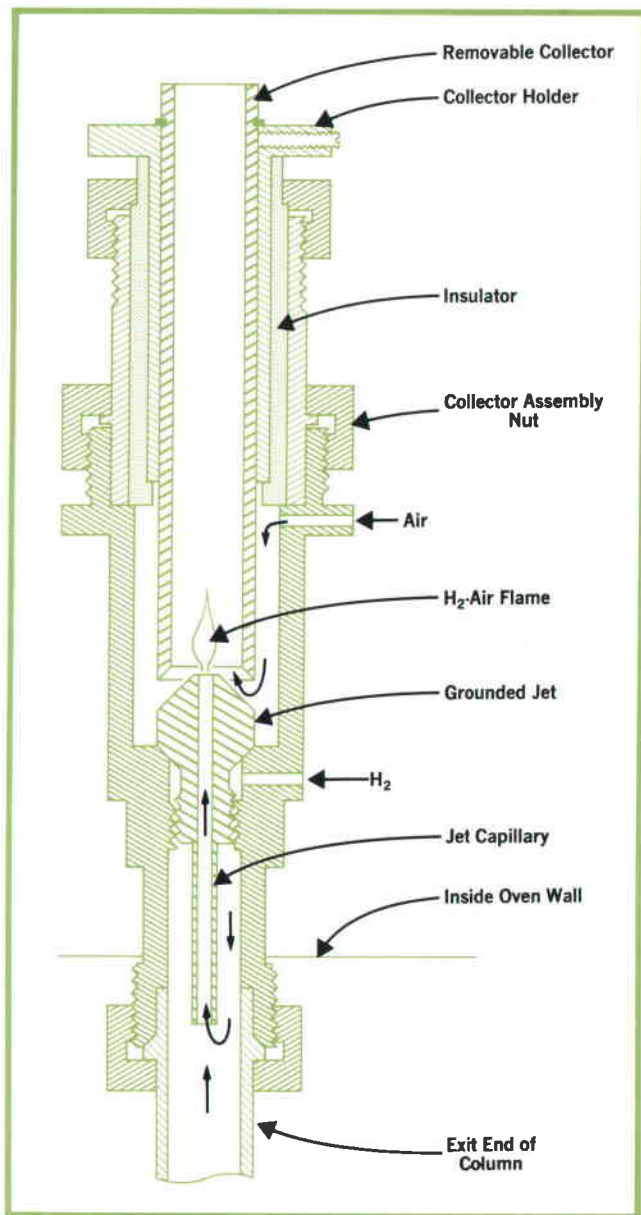

Fig. 1. Cross-section of flame-ionization detector (FID) used in HP 5700A Gas Chromatographs.

As shown in the diagram, the jet body extends down into the column so any dead space is swept by the hydrogen. This eliminates the possibility that molecules of the sample might be trapped here temporarily, widening response peaks. Jets are available in different sizes to match standard column inside diameters.

All column effluent passes through the collector, assuring maximum response. Response of the new detector is linear within a few percent over a sample concentration range of nearly 8 orders of magnitude (Fig. 2). The collector arrangement also makes it possible to measure gas flows accurately right at the top of the collector.

Floating Power Supply

Because of the efficiency of the new FID, the polarizing voltage only needs to be 100 volts. However, the floating supply is required to have very high isolation impedance ($>10^{12}\Omega$) and very low noise. The voltage noise must be kept below 0.5 ppm since it can pump against the collector capacitance, giving rise to current noise.

These requirements were met by the circuit diagrammed in Fig. 3. This circuit uses a 2-MHz oscillator transformer coupled to a tuned load with one voltage-doubler providing a positive voltage and another providing a negative voltage. This allows two detectors to be connected in a differential mode for measurements that use a compensating column. Each voltage output passes through a two-pole filter that reduces noise to levels below 0.5 ppm in a 1-Hz bandwidth.

Electrometers

In prior gas chromatograph practice, electrometers operated as linear current-to-voltage converters using very high-impedance operational amplifiers with large-value feedback resistors (Fig. 4a). The feedback resistors ranged from 10^6 to as high as 10^{12} ohms. An additional high-value resistor and

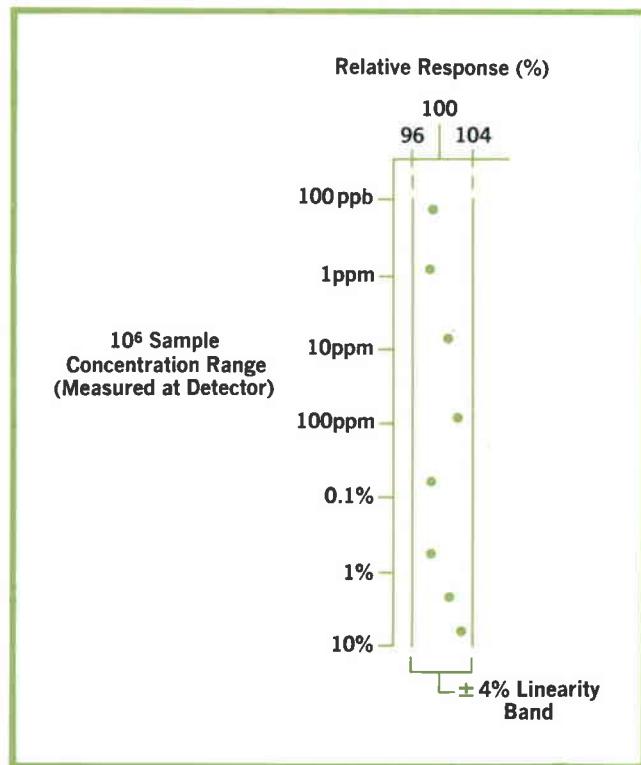

Fig. 2. Relative response of FID plotted over sample concentration range of 6 orders of magnitude shows linearity of response. Measurement was on propane.

Gas Chromatography

Gas Chromatography is a fast, simple, and accurate technique for separating the components of a chemical mixture and measuring the concentration of each. It is based on the fact that the different components of the mixture do not pass at the same rate through a long tube filled with an adsorbent material.

A block diagram of a typical gas chromatograph is shown in Fig. 1. A sample of the substance to be analyzed is injected by a hypodermic syringe through a rubber septum into a heated tube, or column as it is commonly known (a term borrowed from distillation technology, a related discipline). The sample vaporizes and is carried through the column by an inert carrier gas, usually helium, hydrogen, or nitrogen.

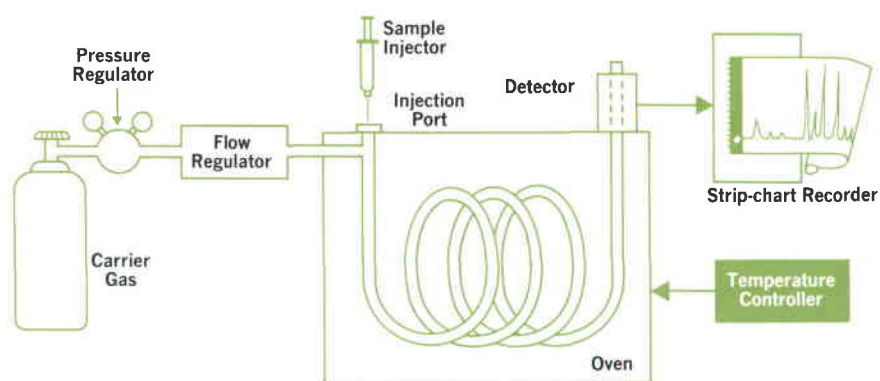

Fig. 1

The column, which commonly is $\frac{1}{8}$ -inch or $\frac{1}{4}$ -inch OD tubing (3 or 6 mm), usually 4 to 12 feet long (1.2 to 3.6 m), is tightly packed with a substance that attracts and retains molecules briefly. Some molecules are retained longer than others, however, depending on their structure. As a result, the various components become separated by the time they reach the end of the column. The first components may emerge from the column within a few minutes of injection whereas the last ones may not emerge until a half-hour or so later.

A detector senses the presence of the components as they leave the column. The detector output is traced on a strip-chart recorder to make a "chromatogram" (Fig. 2). Each peak on the chromatogram represents a component of the mixture. The time of occurrence, or retention time as it is known, aids in identifying the chemical nature of the component. The area enclosed by the peak is a measure of its concentration. Very often, an electronic integrator is used to give a numerical readout of the area.

Detectors

Various techniques are used to detect the chemical components as they emerge from the column. The first practical technique, and one that is still widely used, is thermal conductivity detection. This uses a heated filament placed in the emerging gas stream. The amount of heat lost from the filament by conduction to the detector walls depends on the thermal conductivity of the gas. When there are substances mixed with the carrier gas, the thermal conductivity goes down, the filament retains more heat, its temperature rises,

and its electrical resistance goes up. Monitoring the resistance of the filament with a Wheatstone bridge circuit thus provides a means of detecting the presence of the chemical components.

The flame-ionization detector (FID), a later development, is about 1000 times more sensitive than the thermal conductivity detector. However, whereas the thermal conductivity detector responds to anything mixed with the carrier gas, the FID responds only to substances that produce charged ions when burned in a hydrogen flame. Fortunately, this includes almost all organic compounds.

The FID adds hydrogen to the column effluent and passes the mixture through a jet where it is mixed with air and burned. The ionized gas passes through a cylindrical elec-

trode and a voltage between jet and electrode sets up a current in the ionized particles. An electrometer monitors this current to derive a measure of component concentration. (A more detailed description of an FID will be found in the accompanying article.)

The electron capture detector, a third type commonly used, is even more sensitive but it responds to only a few classes of compounds, mainly those that include a halogen (chlorine, fluorine, etc.). This, however, makes it well suited for identifying and measuring pesticide residues.

continued

n-Hydrocarbons
1 Microliter, Split 150:1
Order of Elution:
n-Heptane
n-Decane
n-Undecane
n-Dodecane
n-Tetradecane
n-Pentadecane
n-Hexadecane

Column:
150 ft. x .01 inch. I.D.
Apiezon C
Temperature: 200°C
Carrier Gas:
Nitrogen, 0.9cc/Min.

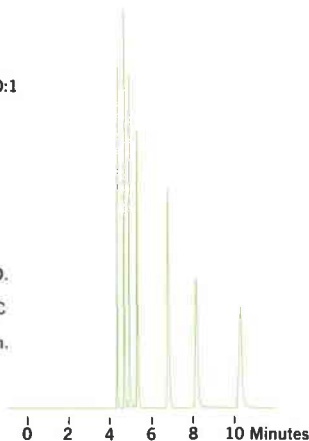
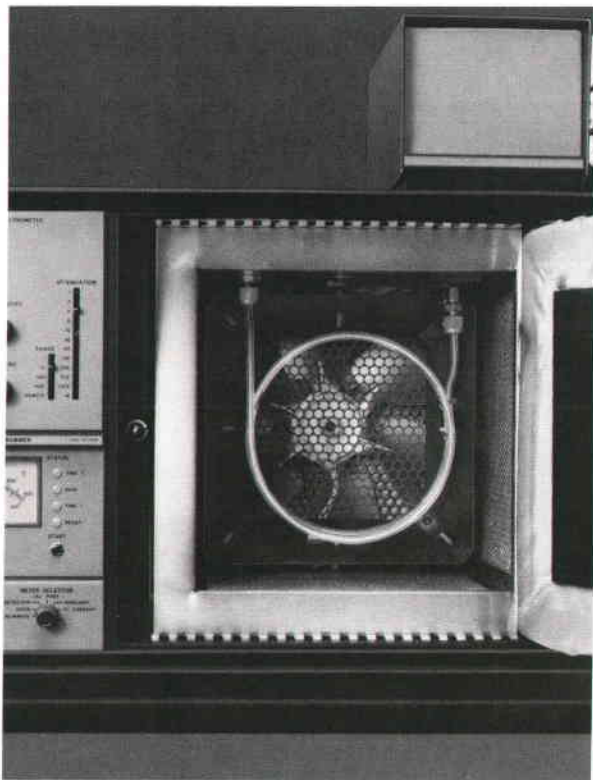

Fig. 2



The electron capture detector has two electrodes with the column effluent passing between. One of the electrodes is treated with a radioisotope that emits high-energy elec-

trons as it decays. These emitted electrons produce many low-energy secondary electrons in the gas, all of which are collected by the other, positively polarized electrode. Molecules that capture electrons as they pass between the electrodes reduce this steady-state current, thus providing an indication of their presence.

Programmed temperature

Many of today's chromatographs use programmed temperature control of the oven, gradually raising the column temperature as the analysis proceeds. This shortens the retention time of "late" molecules so the complete chromatogram is obtained in less time. Shorter retention time also produces sharper peaks. Long retention times usually result in flatter, broader peaks since components tend to diffuse during passage through the column.

Temperature programming, however, increases the possibility that some of the column packing might vaporize or "bleed", a situation that introduces an offset into the chromatogram baseline. For this reason most gas chromatographs use two identical columns; one carries the sample plus carrier gas while the other transports carrier gas only. A dual detector is then used in a differential mode to eliminate any "common-mode" effects from the packing.

Some substances used in the column packings are solid granules, others are nonvolatile liquids absorbed on porous solids. Over two hundred useful liquids have already been identified but the chromatographer may need only a dozen or so of these to be able to analyze most materials.

Systems are calibrated by passing known mixtures of known compounds through the system. The resulting chromatogram then provides a standard that can be used to scale chromatograms of unknowns.

a variable voltage supply were connected to the input to suppress flame background current. These high-value resistors tend to have poor stability with time and temperature, limiting the precision and repeatability of the measurements. Furthermore, range changing was done at high impedance levels, causing large transients. The switching mechanism also increased the number of possible leakage paths.

The traditional technique also puts severe requirements on the noise performance of the operational amplifier, since high signal-to-noise ratios are important for repeatability in peak area quantitation. Current noise at the input limits the most sensitive range. Because the upper current level in the detector is only a few microamperes, the noise level of the electrometer should be no more than a few femtoamperes (10^{-15} A).

Voltage noise at the input, since it appears at the output, limits the dynamic range of the less sensitive ranges. Ideally, an FID and electrometer readout system should span a dynamic range of nearly nine orders of magnitude. On any one range, the electrometer must have a dynamic range of 10^6 to be useful with computers and integrators, and it ought

to be capable of being ranged remotely without introducing long-lasting transients.

To circumvent these problems, a new approach was taken for the 5700A-series FID. This one uses a logarithmic amplifier to span a wide dynamic range at the input. Linearity of the overall response is then restored by an exponential converter following the logarithmic amplifier, as shown in Fig. 4b. Ranging takes place at a low-impedance point between the logarithmic amplifier and the exponential converter.

The circuit is based on the exponential relationship between the emitter-base voltage V_E and collector current I_c of transistors:

$$I_c = I_s \left(e^{\frac{qV_E}{nkT}} - 1 \right)$$

Where I_s is the saturation current.

For forward-biased junctions, the -1 term can be neglected. Assuming the input amplifier of Fig. 4b is ideal (infinite input impedance, no offsets), the emitter voltage V_E of transistor Q1 is given by:

$$V_E = \frac{-nkT}{q} \ln \left(\frac{I_{in}}{I_{s1}} \right)$$

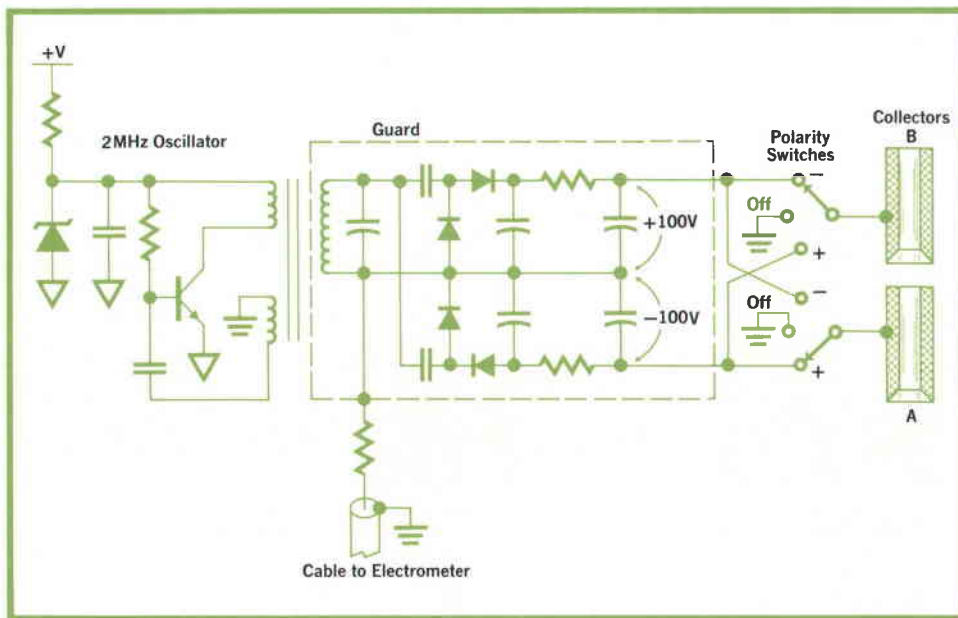

Fig. 3. Block diagram of power supply for FID polarizing voltage.

The base-emitter voltage of the exponential transistor Q2 is increased by the ranging voltage V_R and, assuming the output amplifier of Fig. 4b is ideal:

$$V_{out} = I_{s2} R_f e^{\frac{q(V_E + V_R)}{nkT}}$$

Substitution for V_E yields the overall response:

$$V_{out} = I_{in} R_f \frac{I_{s2}}{I_{s1}} e^{\frac{qV_R}{nkT}}$$

Note that the response is linear with respect to I_{in} . The ratio I_{s2}/I_{s1} is constant, as is q/nkT , because transistors Q1 and Q2 are maintained at a constant temperature near 0°C with a thermoelectric cooler.

Ranging is effected by adjusting V_R in discrete steps (54 mV per decade range). Since this is done at a low-impedance point, ranging transients are eliminated (Fig. 5).

The circuit is easily calibrated by the addition of a small offset to V_R . The improved stability resulting from the constant temperature made it possible to remove the familiar balance control (voltage offset adjustment) from the front panel.

A more detailed diagram of the electrometer circuit is shown in Fig. 6. Because of the impedance transformation between stages, the operational amplifiers need not have both low current noise and low voltage noise. The input stage must have low current noise, but its voltage noise does not appear in the low impedance output. Current noise is held low by the use of a very small geometry JFET and by the thermoelectric cooling.

The output stage must have low voltage noise but its current noise is insignificant because of the low impedance of this stage. Voltage noise is held low by the use of a temperature-stabilized, large-geometry JFET.

The recording of Fig. 7 shows the noise of the electrometer itself to be undetectable in normal operation of the instrument, even at maximum sensitivity of 5 pA full scale (Range: X1; Attenuation:

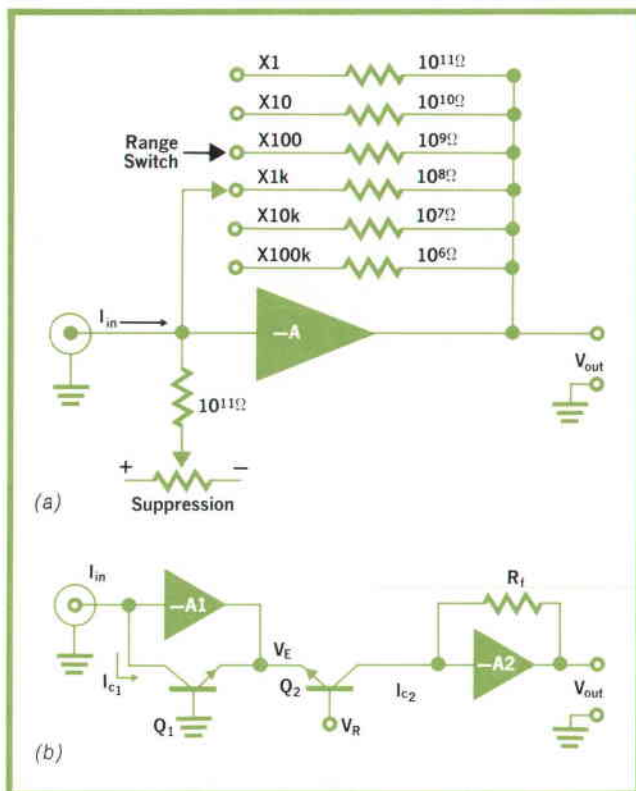

Fig. 4. Conventional electrometer (a) switches feedback resistors to change range. Ranges are changed on new electrometer (b) by switching voltage input, V_R , to exponential-responder transistor Q2.

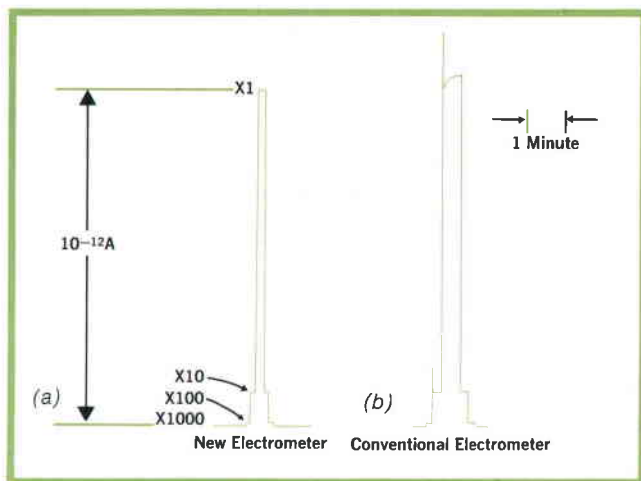

Fig. 5. Range switching with new electrometer (a) causes no transients, as compared to conventional electrometer (b) where large transients are generated when ranges are switched.

X1). The expanded scale portion of the recording shows the current noise to be typically $3.5 \times 10^{-15}A$ peak-to-peak, or $0.6 \times 10^{-15}A$ rms, nearly an order of magnitude better than earlier types.

Flame current offset suppression (zero set) is supplied to the input by a pair of transistors connected as an adjustable current source. This arrangement can cover a much wider current range than was available through a single high-value resistor (see Fig. 4). Ranging is effected by switching in one or both of two voltage sources for V_R , giving four ranges in decade steps (X1 to X1000).

Performance

Unlike earlier FID electrometers that had range-to-range tracking errors of 2 to 10%, the new electrometer tracks within a fraction of 1% (see Fig. 8). Response factors (i.e., calibration) derived on one range may be used on other ranges.

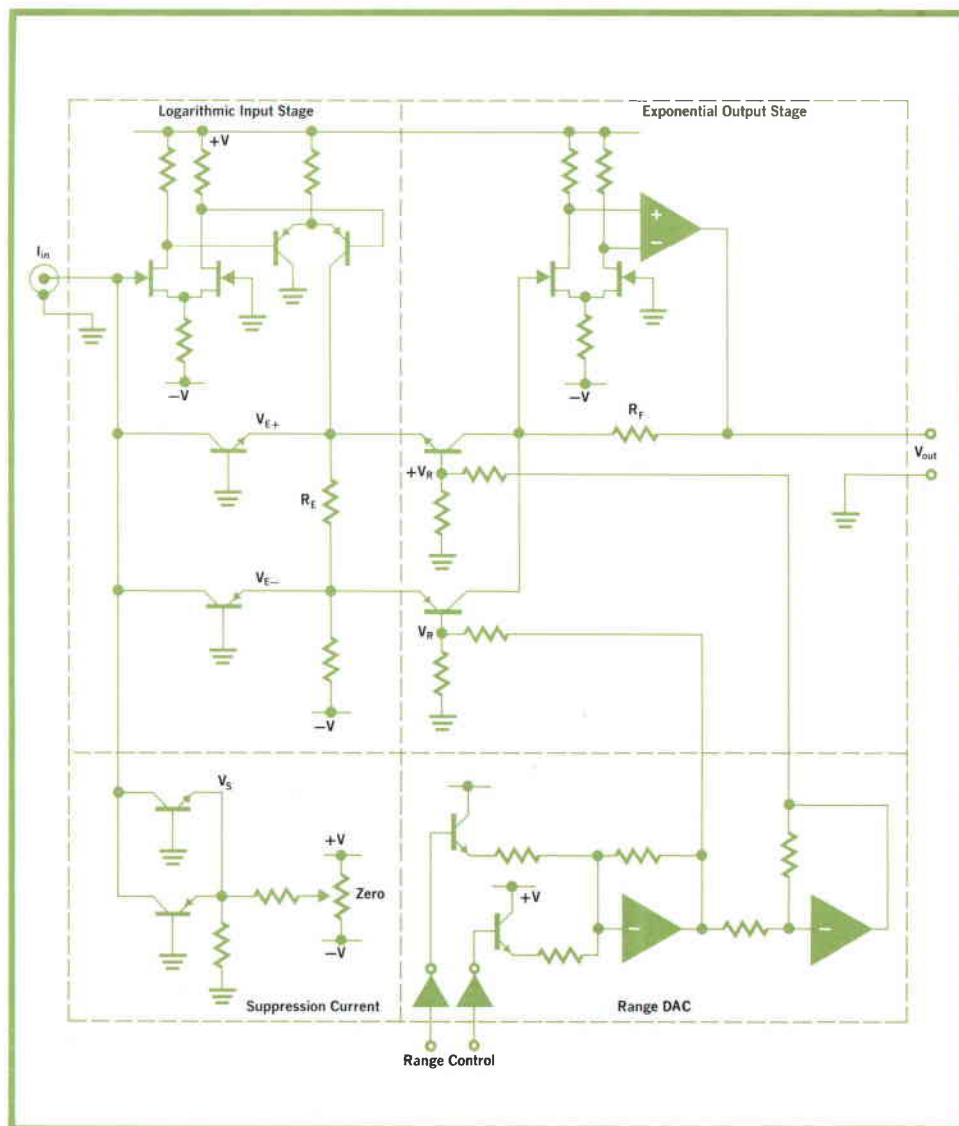

Fig. 6. Simplified schematic drawing of electrometer circuit. Matched pairs of NPN and PNP transistors permit bipolar operation. Constant voltage drop across R_E overlaps plus and minus inputs to log amplifier about $10^{-13}A$ to maintain fast response around zero input current. Range control input can be contact closures or standard 5-volt logic levels.

The 5700A-series Gas Chromatographs

The flame-ionization detector described in the accompanying article is one of several improved components developed for a new series of Hewlett-Packard Gas Chromatographs, the 5700A series.

Because accuracy in gas chromatography depends on temperature stability, gas flow stability, detector linearity and stability, and the degree of exactness with which operating parameters can be reset from run to run, a major design goal with this instrument was to reduce as far as possible all the variables that affect performance—and to do so at reasonable cost. How well the designers succeeded was verified by an extensive series of tests. For example, ten samples of a wide-boiling range hydrocarbon mixture were run in succession, using automatic injection and the thermal conductivity detector. The coefficients of variation for retention time and area percent (measured with an integrator) were less than 0.50% and 0.65% respectively.

To demonstrate control resettability, a series of isothermal analyses was made on different days. The instrument was completely shut down overnight and all controls except flow were changed to different settings. The next day, controls were reset to their initial settings and another series of runs was made. Retention times agreed within better than 0.2% from day to day and peak areas agreed within 0.5%, except for one component at a very low concentration level where agreement was within 1.6%.

This kind of performance was achieved by incorporation of the following concepts in the instrument:

- The temperatures of heated zones within the instrument are controlled within 0.1% by proportional/integral circuits using feedback from platinum temperature sensors.
 - Accuracies of $\pm 0.2\%$ in oven programming times and rates is achieved with an electronic clock generator.
 - Controls operate step-wise rather than continuously to assure exact resettability.
 - The low-mass oven heats rapidly with relatively little power (900 watts); it can be programmed linearly at rates up to $32^{\circ}\text{C}/\text{minute}$ up to 200°C , and up to $16^{\circ}\text{C}/\text{min}$ to 400°C .
 - Oven control includes an additional temperature sensor in the oven wall that inhibits the oven door from closing during cool-down until the wall temperature goes below the starting temperature. The temperature is then brought up to the starting level. This assures a consistent starting temperature from run to run. Since recycling can begin as soon as the oven temperature drops low enough, this system also saves considerable time over those that depend on a timed cycle.
 - A simple, straight-through flow design from injection port to detector minimizes dead volume in the flow system.
 - Controls and adjustments that the operator must make have been reduced in number. For example, oven over-heat protection is designed into the temperature programming circuits. Balance adjustments are no longer required for the electrometer.
 - The new thermal conductivity detector (TCD) uses filaments in sealed cartridges, assuring equal distances from each filament to the wall. Balancing adjustments are no longer needed for the detector bridge and the detector is also much less sensitive to "common-mode" changes in temperature and flow. It easily detects components in the ppm range.
- The new flame-ionization detector (FID) uses a grounded jet and realizes 100% flow through the collector for improved signal-to-noise ratio.
 - A new electrometer for the FID has a noise level below flame noise and a dynamic range that is linear within 1% over a range of 10^7 to 1, about 10 times greater than previous designs.
 - The electrometer can be ranged during a run without up-setting the calibration factor or introducing long-lasting transients, even on the most sensitive ranges. This is an important consideration where the chromatograph is to be used with an integrator or a computer.
 - A new electron-capture detector (ECD) uses a pulsed potential with pulse rate controlled by feedback to maintain the average current constant (the pulse rate is thus an indicator of component concentration). This method extends linear response over a dynamic range of 10,000 to 1, about an order of magnitude better than previous types.

Other features of the instrument that contribute to operator convenience are:

- The oven shell is surrounded by circulating room air. This plus effective insulation allows the instrument surfaces to be touched, even when the oven interior is at 400°C .
- Oven controls are on a flip-out panel, readily accessible when needed but otherwise protected from the curious passerby who can't resist pushing buttons.
- Detectors are mounted on top of the oven where they can be interchanged within 15 minutes.
- Gas flow rates can be measured conveniently at the output of any of the three detectors.

The 5700A Gas Chromatograph is a dual-column instrument with interchangeable detectors. Construction is modular, allowing it to be configured to the individual chromatographer's needs without including capabilities he may not use. For example, subambient temperature control (using CO_2 coolant) can be obtained by merely plugging a printed-circuit board into the standard temperature programmer.

The instrument's compactness (only $22\frac{1}{4}$ inches wide) and simplicity of control recommend its use for simple and routine analyses while its modularity and control versatility make it just as well suited for automatic systems.

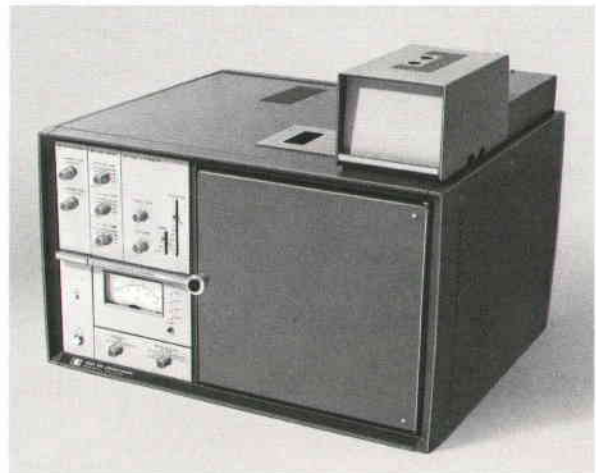

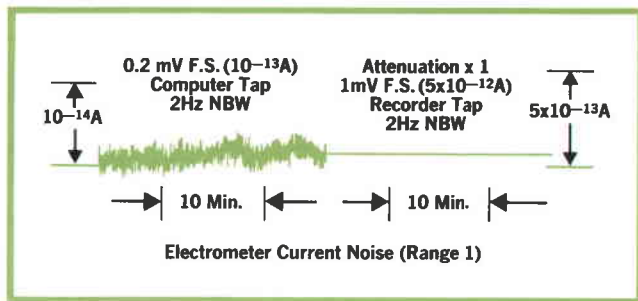

Fig. 7. Electrometer noise is not visible on recorder trace during normal operation of instrument on most sensitive range. Expanded scale portion (left half) shows noise to be about 3.5×10^{-13} A peak-to-peak.

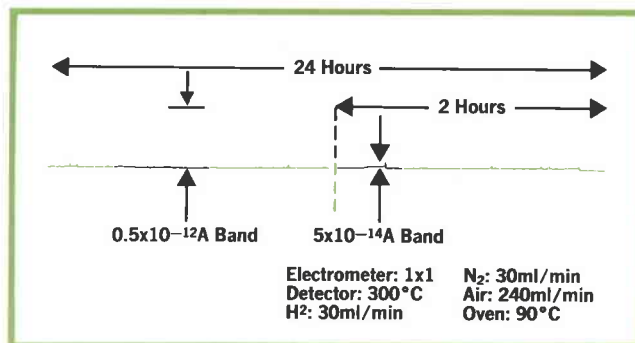

Fig. 10. Stability of 5700A Gas Chromatograph with FID output.

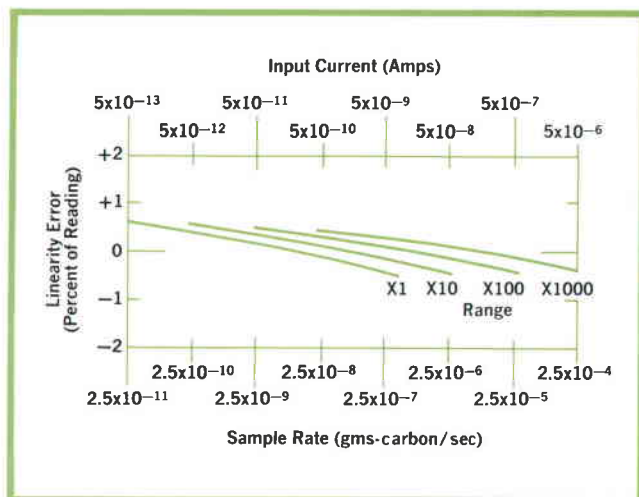

Fig. 8. Linearity error of new electrometer as a function of input current remains within $\pm 1\%$, and range-to-range tracking errors are only fractions of 1%.

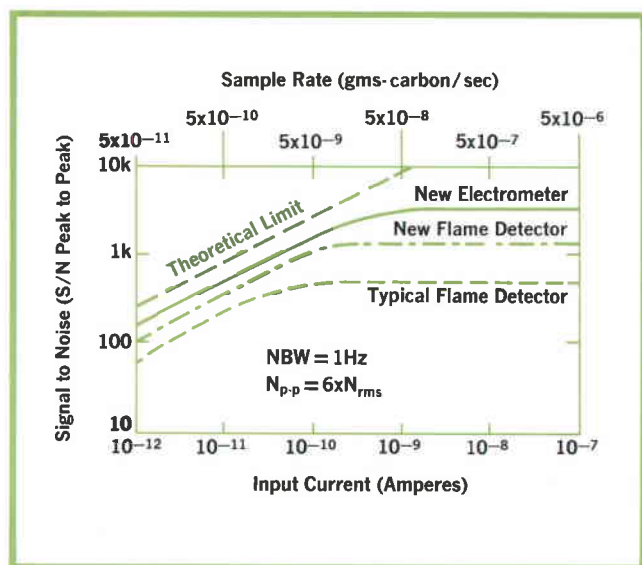

Fig. 9. Signal-to-noise ratios of new electrometer and flame detector as function of current, compared to earlier flame detectors and to theoretical limits.

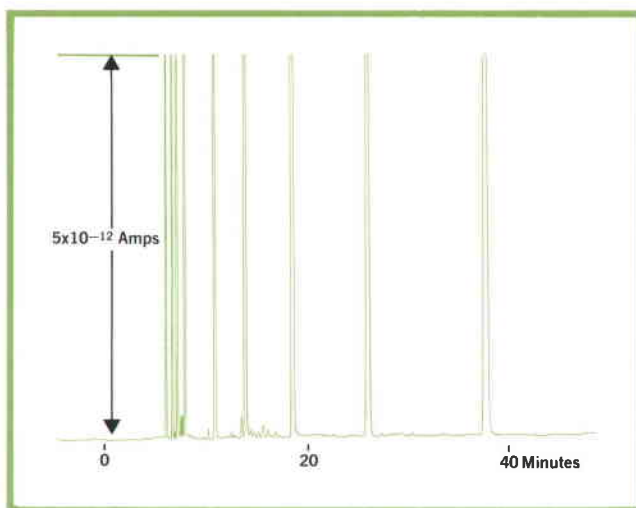

Fig. 11. Chromatogram generated by 5700A Gas Chromatograph using new FID shows low amount of noise on baseline (sample was *n*-paraffin blend using 150-foot capillary column with instrument set to Range 1, Attenuation 1).

ABBREVIATED SPECIFICATIONS

HP Model 5700A Gas Chromatograph

COLUMN OVEN: Accepts dual columns with 6" (15 cm) diameter coil of 1/16, 1/8, 1/4 inches (1.5, 3, 6 mm) OD, metal or glass, packed or capillary.

ISOTHERMAL CONTROLLER AND LINEAR PROGRAMMER

RANGE: -50°C to +399°C (with sub-ambient option).
SET POINT: 1°C steps above 0°C; 10°C steps below 0°C; directly calibrated.

REPEATABILITY: better than 0.5°C at constant ambient.
ABSOLUTE TEMPERATURE ACCURACY: ±2% in degrees Kelvin.
STABILITY: Better than 0.1% of set point (heating mode).

LINEAR PROGRAMMER ONLY

PROGRAM RATES: 0, 1, 2, 4, 8, 16 and 32°C/min.
INITIAL TEMPERATURE: 1°C steps above 0°C; 10°C steps below 0°C.

FINAL TEMPERATURE: 10°C steps.
INITIAL AND FINAL TIMES: 0, 1, 2, 4, 8, 16 and 32 min (plus infinity, for hold at upper temp.).
REPEATABILITY: 0.1%.

DETECTOR, INJECTION & AUXILIARY TEMP. CONTROLLERS

RANGE: 100°C to 400°C in 50°C steps.

FLAME IONIZATION DETECTOR

TYPE: Dual; can be operated as single (A or B) or in compensation mode; grounded jet; integral gas controls for H₂, air, auxiliary.
SENSITIVITY: >0.015 coulombs/gram hydrocarbon in air.
MIN. DETECTABLE LEVEL: better than 5 x 10⁻¹² g/sec for hydrocarbon.
LINEARITY: >10⁷.

ELECTROMETER

SENSITIVITY: 5 x 10⁻¹² A full scale on max. sensitivity (Range 1, 1 mV Recorder).
DYNAMIC RANGE: >10⁶ on all ranges, limited only by flame noise.
DRIFT: 4 x 10⁻¹⁴ A/hr at constant ambient.
LINEARITY: ±2% including range-to-range tracking.
TEMPERATURE COEFFICIENT: 1 x 10⁻¹⁴ A/°C change in ambient.
CURRENT NOISE: 1 x 10⁻¹⁴ A with input capped (2 Hz noise BW).
BACKGROUND SUPPRESSION: up to ±1 x 10⁻⁶ A in single exponential range, with coarse and fine controls.
OUTPUTS:
RECORDER: ±1 mV fs, <1.3 kΩ impedance; 2 Hz noise BW.
INTEGRATOR: ±1 V fs, 1 kΩ impedance; 2 Hz noise BW.
COMPUTER: ±10 V fs, 1 kΩ impedance; 10 Hz noise BW.
OPERATING TEMPERATURE RANGE: 5°C to 45°C ambient.

TC DETECTOR

TYPE: dual, four-filament, sealed in replaceable cartridge, passivated.
MIN. DETECTABLE LEVEL: 4 x 10⁻¹⁰ g/ml (based on propane, at 100°C, 300 mA).

EC DETECTOR

TYPE: Variable pulse repetition rate with constant cell current.
DYNAMIC RANGE: 10,000 to 1.
MIN. DETECTABLE LEVEL: 1 picogram of lindane at S/N of 3.
SOURCE: 15 millicuries ⁶³Ni, plated on detector wall (AEC license required; applications available at HP Sales Offices). Detector may be disassembled and cleaned.

INJECTORS: Four interchangeable dual injectors, heated or on column, 1/4 or 1/8 inch (3 or 6 mm) OD; plus injection port/splitter for capillary columns.

PHYSICAL

SIZE: 13 1/2 in (18 1/2 in including detector) H x 22 1/4 in W x 19 in D [34.3 (47.0) x 56.2 x 48.3 cm]
WEIGHT: 85 lbs (38.5 kg) typical net weight.
POWER CONSUMPTION: 1800 VA max.
SUPPLY REQUIREMENTS: 115 V or 230 V ±10%, single or split phase, 48-66 Hz.

PRICE IN USA: Typical system with dual FID and isothermal oven controller (Model 5711A): \$2995.

MANUFACTURING DIVISION: Avondale Division
Route 41 and Starr Road
Avondale, Pennsylvania 19311

Acknowledgments

The flame detector design was based on several ideas presented in a breadboard version by Lou Mikkelsen. The excellent mechanical design of the production unit, which provided much of the performance improvement, was by Roger Nalepa. William Buffington made many significant contributions in the design of the floating bias supply. Ernest Zerenner, John McFadden and Hans Van Heyst were responsible for the electrometer. Robert Bump showed the feasibility of the electrometer concept with an early breadboard. The overall success of the 5700A-series Gas Chromatographs is due to the dedication and leadership of project leader Dieter Hoehn.

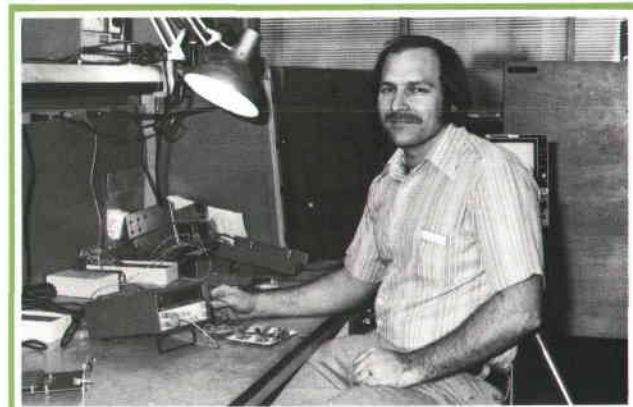
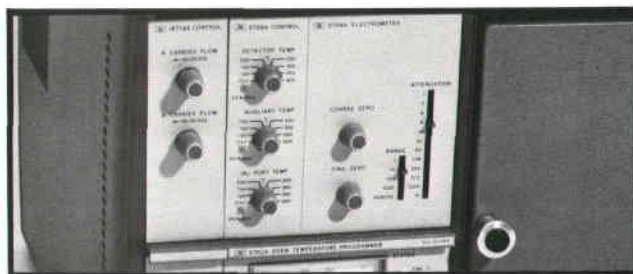

Douglas H. Smith

Doug Smith's first job out of the University of California at Berkeley (BSEE in Computer Sciences, 1964) was designing counters and DMV's. Later he earned an MSEE at UCB (1967), and then went to work on the electronics for amino acid analyzers.

Doug joined HP Labs in 1968 to work on medical instrumentation. He transferred to HP's Avondale Division two years later where he was a section leader on advanced gas chromatography before taking on the electrometer and FID project. He recently returned to HP Labs where he is working on optical instrumentation.

Although he and his wife have three children of their own (8, 6, and 2), they also serve as foster parents for two teenagers. Doug likes to make furniture and he likes basketball, swimming, and water skiing. He also plays volleyball with the Palo Alto Industrial League.

Synthesized Signal Generation to 1.3 GHz

Because they maintain quartz-crystal stability at all frequencies over a wide range, frequency synthesizers find growing use in testing procedures. With the system described here, synthesizer applications can now extend well into the UHF range.

By Roland Hassun, Melvin Humpherys, Dieter Scherer, Young Dae Kim, Bradley Stribling, and Charles Cook

FREQUENCY SYNTHESIZERS GAINED A BROADER RANGE OF APPLICATIONS with the introduction of the Hewlett-Packard 8660-series Synthesized Signal Generators.¹ The inclusion of AM and FM modulation capability with the ability to deliver calibrated output power over a wide range would normally classify these instruments as signal generators. However, they retain a synthesizer's frequency stability and accuracy and its ability to change frequency rapidly under programmed control. In addition, these instruments can generate step-wise frequency sweeps, in which the frequency at each step has the accuracy of the basic crystal reference, and this enhances their usefulness as bench instruments for design work as well as for use in automatic test systems.

Now that the Model 86602A plug-in RF Section for the 8660 system (Fig. 1) has reached production

status, this capability extends all the way up to 1.3 GHz, a capability that was made possible by hybrid thin-film microcircuit technology.

The 8660 system is thus among the first UHF synthesizers to operate at frequencies up to 1 GHz, making synthesizer capabilities available for testing UHF communications equipment, particularly narrowband, crystal-controlled communications receivers. Also, all front-panel functions (frequency, level, modulation type and depth) are programmable so the new system can be used in automatic test systems.

The new RF Section's wide 1–1300 MHz range makes it useful for the lower frequency VHF, RF, and IF bands as well as the UHF band. Also, the 1.3 GHz range and 1-Hz resolution will be of interest to those who synthesize microwave frequencies by multiplying up from a lower frequency—the base



Fig. 1. Model 86602A 0.1–1.3 GHz RF Section (right foreground) is newest member of HP 8660-series Synthesized Signal Generator family. Other RF Section (Model 86601A) covers 0.01–110 MHz range. Family also includes two Auxiliary/Modulation sections (left foreground). Model 8660A mainframe (left rear) with switch selection of frequency is intended primarily for automatic test systems. Model 8660B (right rear) has pushbutton control of frequency that also gives automatically sequenced step-wise frequency sweeps. All functions operable from front-panel of all plug-in sections and both mainframes (frequency, output level, modulation, modulation depth) are programmable.

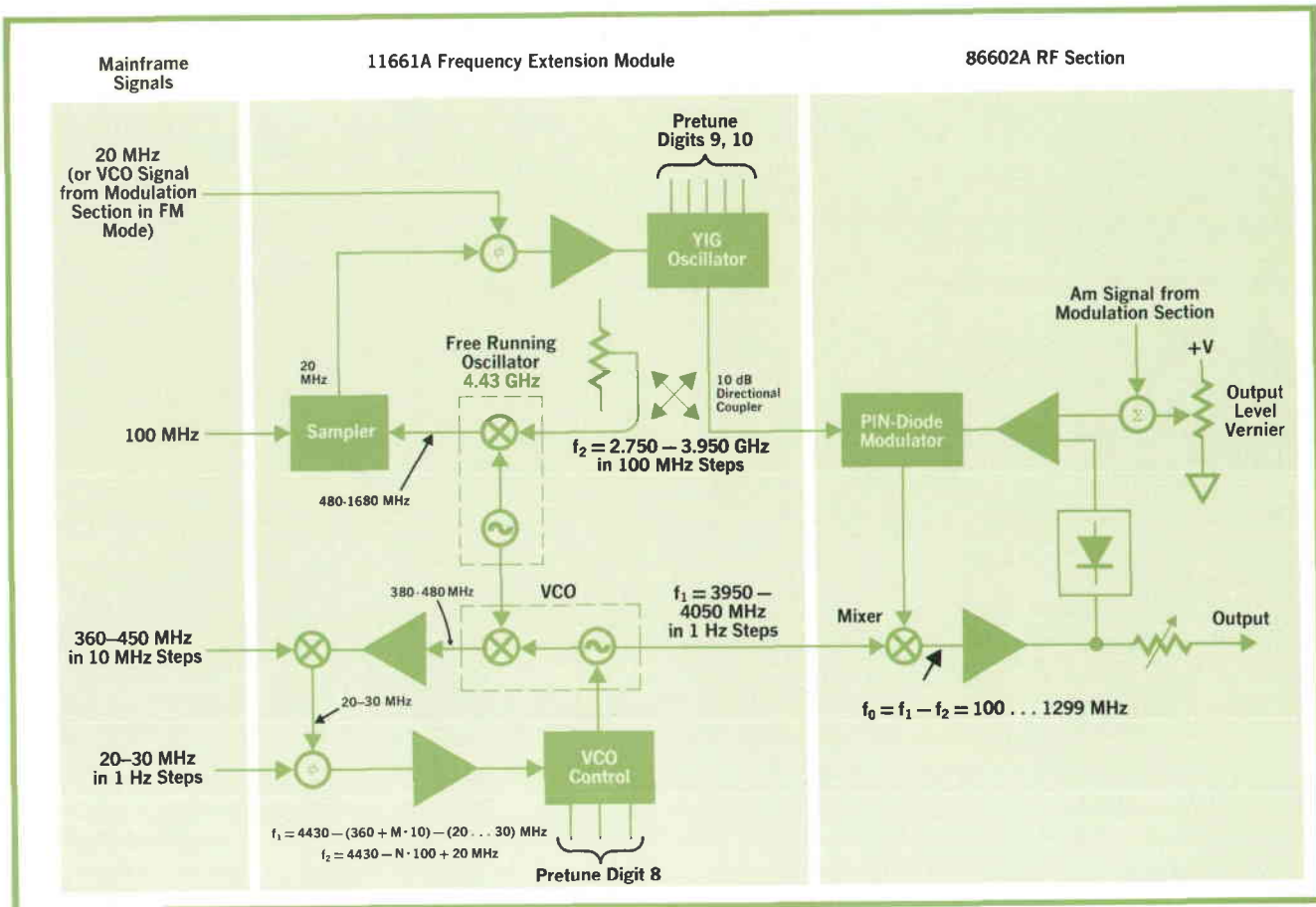

Fig. 2. Block diagram of 1-1300 MHz frequency generation. YIG oscillator is tuned in 100 MHz steps by digital control signals, then locked to mainframe 20-MHz reference through chain of frequency conversions in phase-lock loop. VCO is locked to mainframe frequency derived from choice of 1-Hz-to-10-MHz frequency-selection digits. Output frequency is difference between YIG and VCO frequencies.

frequencies provided by this instrument require fewer multiplication steps and thus are not subject to as much signal-to-noise degradation.

Signal Purity

The frequency agility of a frequency synthesizer comes at a price: because signals at many different frequencies exist simultaneously within a synthesizer, a major effort is required to keep spurious signals in the output at a low level, if the instrument is to qualify as a signal generator. Execution of the synthesis scheme used in the new 1.3-GHz system was thus molded by considerations of spurious outputs. As a result, except for a few qualifications to be discussed later, spurious outputs from the 1.3-GHz RF Section are more than 80 dB below the output at all output frequencies. The 8660 system may therefore be used for critical RF testing except where an extremely low noise floor, such as that provided by the HP Model 8640A/B Signal Generator described in last month's issue, is needed.

A block diagram of the new 1.3-GHz system is shown in Fig. 2. Actually, the 1.3-GHz system is divided into two modules: an internal plug-in that derives the needed 100-MHz frequency steps (the Model 11661A Frequency Extension Module), and a front-panel plug-in that has the output circuits (the Model 86602A RF Section).

The internal module has two frequency-generating loops. One derives the 100-MHz steps and the other serves as a summing network for the mainframe signals representing the remaining digits. So the outputs of these two loops may be combined without generating difficult-to-remove mixing products, the loop oscillators operate at microwave frequencies (more about this later). The two loop outputs go to the front-panel plug-in where their difference, the desired output frequency, is obtained.

The difference frequency is amplified to a 1-volt level and it then goes to the output attenuator. This gives the wide range of output levels needed for signal generator applications (down to 0.01 μ V).

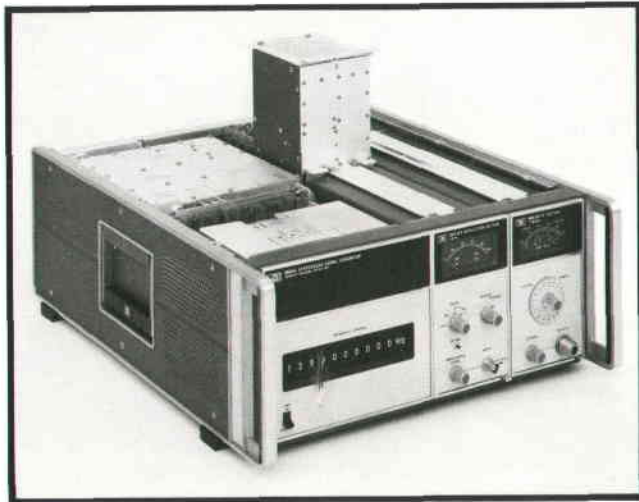

Fig. 3. Frequency Extension Module, shown here raised, plugs into mainframe. Although used only with 1.3 GHz RF Section, it may be left in place when 0.01–110 MHz RF Section is installed.

One of the two signals into the final mixer is made large enough to serve as the LO signal so level control and amplitude modulation can be performed on the other. A detector at the output of the amplifier closes the level-setting control loop. The modulator, output mixer, and output amplifier are all included within the loop and as a result, the output level is held constant within ± 1 dB across the entire 1–1300 MHz range specified for the instrument, as shown in Fig. 4 (the 1.3-GHz system is also usable down to 200 kHz with relaxed specifications). Stability of the output of a unit selected at random is shown by the recording of Fig. 5.

Modulation

Amplitude modulation is performed by way of the leveling loop under control of one of the other sections that plug into the 8660 mainframe, such as the Model 86632A AM/FM Modulation Section described in a recent issue of the HP Journal.² Bandwidth of the AM system is 50 kHz.

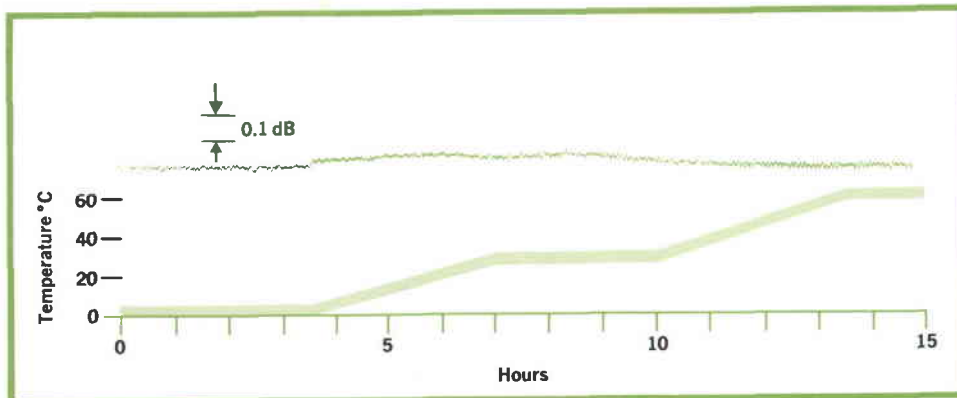

Fig. 5. Output level stability in varying ambient temperature. Lower trace shows temperature profile of environmental chamber in which test was made. Noise-like variations in output result from 5° temperature variations caused by chamber's on-off heat control system.

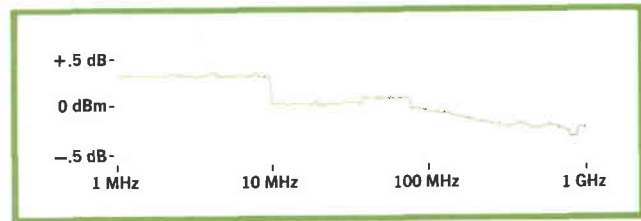

Fig. 4. Frequency response plotted at 0 dBm output level.

Frequency modulation is applied to the 20-MHz reference signal used in the YIG oscillator loop (see Fig. 2), giving a modulation bandwidth of dc to 200 kHz and maximum deviation of 200 kHz. FM of the 20-MHz reference is performed in the Model 86632A AM/FM Modulation Section.

Choice of Frequencies

The choice of frequencies, f_1 and f_2 , for the two loops in the Frequency Extension Module (Fig. 2) were based largely on the behavior of spurious mixing products that result from mixing these two signals. Because the mixer output, f_0 , covers a wide range of frequencies (1–1300 MHz), many of the harmonics can satisfy the mixing equation

$$nf_1 \pm mf_2 = f_0$$

The choice of loop frequencies shown in Fig. 2 has these effects:

- Third order products ($f_1 \pm 2f_2$ and $2f_1 \pm f_2$) never appear within the 1.3-GHz output band, although they may approach to within 150 MHz of the signal at the highest output frequency.
- Fifth order products never appear in band for output frequencies below 899 MHz. At higher output frequencies, when they do appear they never come closer than 50 MHz to the output, "jumping across" the output rather than "crossing through" (see below).
- Seventh order products never appear in band for output frequencies less than 680 MHz and when they do occur, they behave in the same way as the fifth order products, leaving the ± 50 -MHz

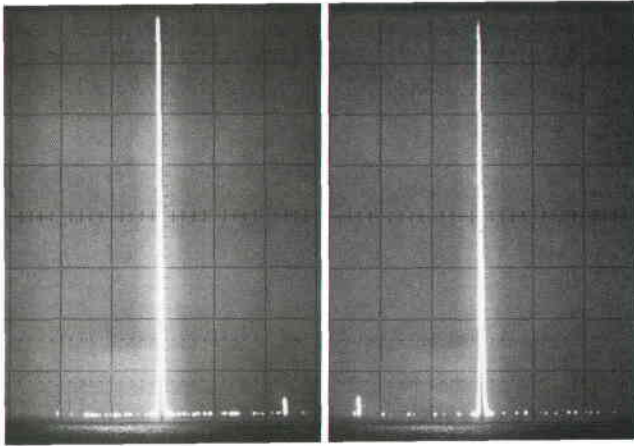

Fig. 6. Spurious outputs always lie outside ± 50 MHz band centered on output. Fifth-order spurious output is 50 MHz above output frequency of 999.999 MHz (left photo) but jumps to 50 MHz below when output is stepped to 1000.000 MHz (right photo).

spurious-free band around the output signal.

All other mixing products are sufficiently suppressed in the output mixer to be well below 80 dB when near the output frequency.

To illustrate how fifth and seventh order products "jump across", consider the following example. The Synthesizer is being stepped upwards in frequency towards 1000 MHz; f_1 would then be about 4050 MHz and f_2 about 3050 MHz. The fifth-order spurious signal would be 1050 MHz, the difference between $2f_1$ (8100) and $3f_2$ (9150), and moving toward a projected intercept with the output frequency at 1016 MHz. However, as the instrument steps from 999.999 to 1000.000 MHz, a 100-MHz increment occurs in f_1 , which then goes to 3950 MHz while f_2 goes to 2950 MHz. The fifth-order spurious signal therefore jumps to 950 MHz (Fig. 6), moving away from f_0 as f_0 goes higher, and never entering the ± 50 -MHz spurious-free band.

Wide Capture Range Phase Detectors

In the design of the two phase-locked loops, a common problem was encountered: how to obtain a capture range well in excess of the bandwidth of the loop transfer function. One way is to detect a loss of lock and activate a signal that sweeps the oscillator through its range until lock can be re-established. This approach is used for the YIG oscillator in the Frequency Extension Module. A rather sophisticated compensation network in the phase-lock loop assures a flat transfer function and a bandwidth of 500 kHz which allows the search rate to be 125 MHz/ms.

A bandpass filter for removing spurious signals in the YIG loop was not needed in the VCO loop, so

a digital phase/frequency detector is used here. Unlike detectors that respond to phase differences only, this one also provides a dc correction voltage where there is a frequency difference, thus giving an arbitrarily large capture range independent of loop bandwidth.

The phase/frequency detector is diagrammed in Fig. 7. To see how it works, suppose both flip-flops (FF1 and FF2) are reset. A signal at the input to FF1 sets that flip-flop, which remains in that state until the signal at the input to FF2 sets FF2. Both flip-flops are then reset immediately by the reset gate.

As shown by the waveform diagrams of Fig. 7, the average voltage out of FF1 is larger, so the output of the differential amplifier is a positive dc. Had the input to FF2 occurred first, the output would be a negative dc. Thus, the output of the differential amplifier can be used as a VCO correction voltage.

A frequency difference is equivalent to a sweeping phase difference. The filtered output is then a sawtooth wave that has a fixed average dc value of the proper polarity to tune the VCO.

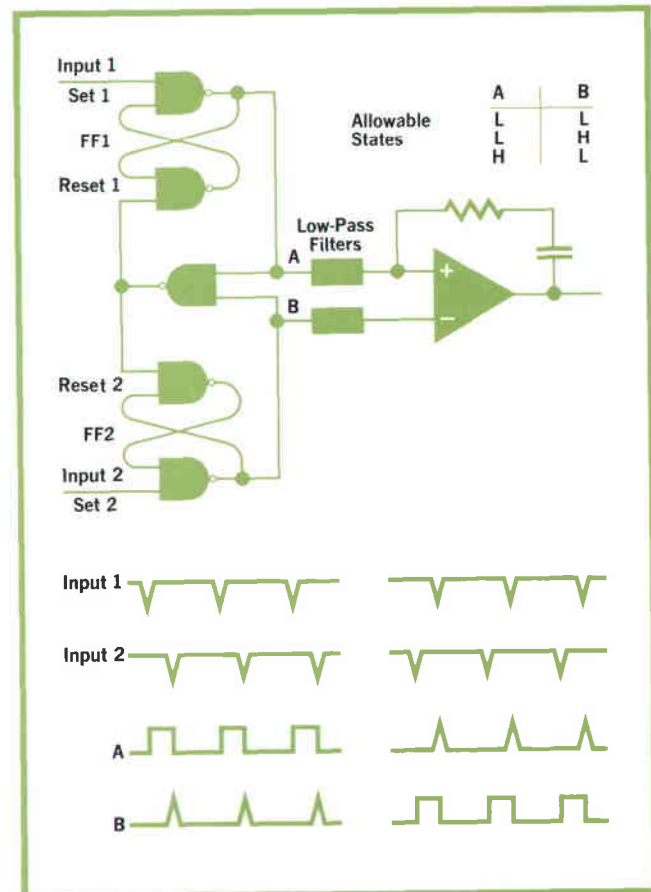

Fig. 7. Phase-frequency detector, useful with inputs up to 50 MHz, has high-speed Schottky TTL gates in three-state logic configuration. Waveforms show how outputs proportional to phase difference are generated.

Spurious Generating Mechanisms

Signal leakage between the two loops can be a significant source of spurious signals, therefore careful attention was paid to shielding and isolation.

Another potential source of spurious generations results from the presence of a sampler, used as a mixer, in the YIG oscillator loop. Consider the following situation:

- The free-running oscillator, used to translate the YIG and VCO outputs to suitable frequencies for phase comparisons with the mainframe signals, is operating at some frequency offset Δ from its nominal frequency of 4430 MHz.

- Number 9 is selected in the 100-MHz column, thus making the YIG frequency $(3050 - \Delta)$ MHz.

In the YIG loop, the IF mixer output is $(4430 - \Delta) - (3050 - \Delta) = 1380$ MHz. However, the third order mixing product, $2(3050 - \Delta) - (4430 - \Delta)$, gives $(1670 - \Delta)$ MHz. When sampled at a 100-MHz rate, $(1670 - \Delta)$ gives a component at $(30 - \Delta)$ MHz in addition to the desired 20 MHz. For this reason, it was necessary to assure that Δ would never exceed

5 MHz so the undesired frequency components can be removed by the 20-MHz IF filter.

Phase Noise

Phase noise is an important consideration in evaluating signal quality. In the new 1.3 GHz system, noise within 50 kHz of the output frequency is determined by the mainframe signals, but outside that band, the free-running 4.43-GHz oscillator becomes an important factor. Holding phase noise to a desirable level was a major objective in the design of the oscillator. Another important consideration was the transfer functions of the two phase-lock loops that involve the 4.43-GHz oscillator. The transfer functions were made as nearly identical as possible to assure good cancellation of the oscillator noise in the output mixer. Overall phase noise is shown in Fig. 8.

Circuit Technology

As mentioned before, the higher frequency performance of the new 1.3 GHz system was made pos-

A 0.1 to 1300 GHz Amplifier

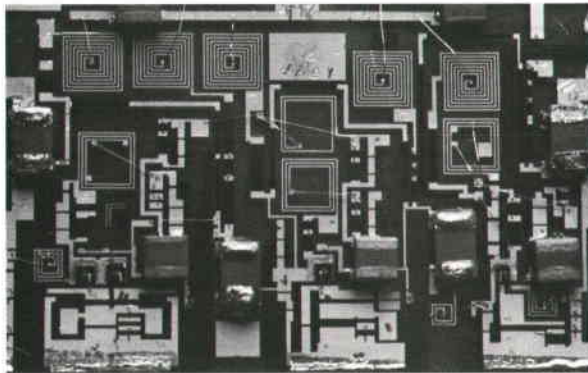

A key element in making 1.3 GHz performance possible in the Model 8660A/B Synthesized Signal Generator, and in several other instruments as well, is the hybrid integrated circuitry like that shown above.

Two circuits, a preamplifier and a power amplifier, together form the output amplifier of the Model 86602A RF Section. Each is fabricated on a polished sapphire substrate, 0.46 x 0.69 inch in area, with the capacitors, resistors, and spiral inductors for the matching and feedback networks formed by thin-film techniques. In addition, 50 x 50 mil capacitor chips with capacitances as high as 15,000 pF are used for decoupling each stage and for low-frequency compensation. The capacitor chips are placed in such a way that their parasitic capacitance to ground becomes part of the matching networks.

The transistors are HP types 35820 and 35830 in chip form. These permit the connecting leads from substrate to emitter pads on the chip to be very short for minimum parasitic inductance, a necessity for high-frequency performance. Also, the small size of each chip and the precision

possible with thin-film techniques allow the emitter feedback circuitry to be lumped right at the edge of the substrate (the bottom edge in the picture) to minimize the path length to the ground plane, essential for providing a closely controlled emitter impedance.

Collector and base of each stage are shunted by RCL networks. The distributed capacitance of some of the spiral inductors posed some problems but these were resolved by use of relatively open geometry, such as in those in the central portion of the power amplifier shown in the photo.

The 3-stage preamplifier uses three HP 35820 transistors, achieving a gain of 26 dB over a frequency range of 0.1 to 1300 MHz with flatness better than ± 1.5 dB, typically ± 1 dB. Extending the low-frequency response down to 0.1 MHz while designing for low noise figure required some compromises in the choice of feedback elements of the first stage. Nevertheless a noise figure of 7 dB is achieved. VSWR is better than 2 at the input and output.

The 3-stage power amplifier uses an HP 35820 transistor in the first stage, one HP 35830 in the second, and two in parallel in the third stage, shown in the lower left hand corner of the photo (signal flow is from right to left). Gain is 22 dB \pm 1.5 dB over the 0.1 to 1300 MHz frequency range and the amplifier yields an output power of +17 dBm at 1-dB gain compression. At +13 dBm, all harmonics are more than 30 dB down. (Both amplifiers use +20 V bias.)

Not only is this amplifier combination a key part of the Model 86602A RF section, but the amplifiers are also used in the 86220A 0.01–1.3 GHz RF plug-in for the 8620A/B Sweep Oscillators and the 8444A Tracking Generator, as well as in a number of other instruments under development. In addition, they are available as instrumentation amplifiers packaged with a power supply (8447 series) and are also available by themselves as circuit components.

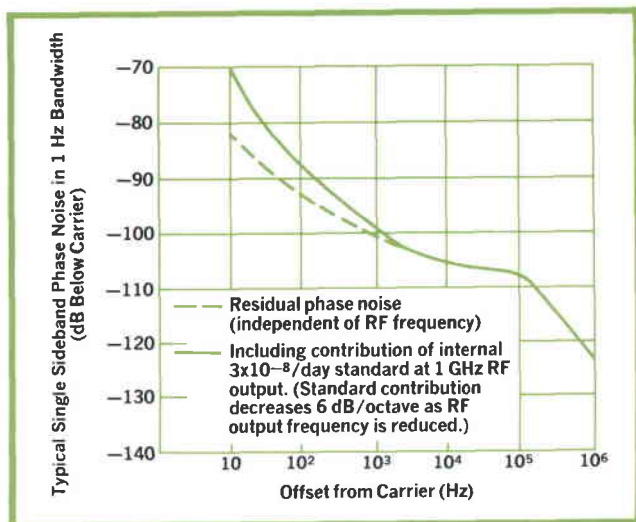

Fig. 8. Phase noise in 1-Hz bandwidth.

sible by hybrid-thin-film microcircuit technology, which makes stable performance over an extremely wide band of frequencies possible. A case in point is the free-running 4.43-GHz oscillator. As discussed earlier, requirements on this oscillator were low drift and low phase noise (<40 ppm/ $^{\circ}$ C and about 110 dB signal-to-noise ratio in a 1-Hz bandwidth 100 kHz from the carrier). The circuit was also to include a well-balanced mixer.

The resulting design is shown in Fig. 9. It uses a push-pull transistor configuration that provides two signals with a 180° phase difference, allowing simple realization of a two-diode, single-balanced mixer, and it establishes two RF nulls, at points 2 and 5, that allow biasing without bulky and lossy decoupling elements.

The effects of temperature on frequency result from thermal expansion (-8 ppm/ $^{\circ}$ C), changes in the dielectric constant of the sapphire substrate (-80 ppm/ $^{\circ}$ C), and the cumulative effects of collector voltage (-24 ppm/ $^{\circ}$ C). These can be compensated for by the adjustable positive temperature effect of the emitter-base capacitance, which is also a function of the collector-base voltage. At $+9$ volts, total drift is typically less than 20 ppm/ $^{\circ}$ C, well within design goals.

Oscillator phase noise is determined primarily by the Q of the strip-line resonator, which depends on substrate thickness. A 25-mil substrate gives an unloaded Q of 200, with an operating Q of about 100.

The mixer uses two matched beam-lead Schottky-barrier diodes, driven by the oscillator at a $+10$ dBm level. The RF signal comes in at point 1 through a 3-dB pad. The lowest order intermodulation product that gives rise to an in-band signal is the 10th order ($4f_{LO} \pm 6f_{RF}$) which is typically -100 dBm for

a $+3$ -dBm RF input. Conversion loss is typically 17 dB including the effects of the two 3-dB pads.

A similar oscillator/mixer combination is used for the VCO but with voltage-variable capacitance added for frequency control.

Other construction techniques are used, however, where desired performance can be achieved at low cost. Bandpass filters in the Frequency Extension Module, for example, are made by etching an interdigitated stripline pattern on both sides of a 5-mil epoxy-glass board, and sandwiching it between aluminum channels filled with low-loss dielectric material.

Mixer Suppression

In the RF Section output circuits, concern for spurious signal generation dictated the assignment of ports for the output mixer. Because the YIG oscillator operates at a relatively high level, it would seem natural to assign f_2 to the LO port and assign f_1 to the RF port. The modulator would then need to operate only over a narrow band of frequencies. Quite the opposite occurred, however, even though doing so required the addition of an amplifier to bring f_1 up to a suitable LO level and the use of a wideband modulator for f_2 .

This was done for the following reason. As noted above, there are fifth and seventh order mixing products that can fall within the 1–1300 MHz output range of the mixer. These are $2f_{LO} - 3f_{RF}$ and $3f_{LO} - 4f_{RF}$. If a balanced mixer is used, even-order f_{LO} terms will be suppressed, reducing the fifth-order term to about the same level as the seventh order term. By using the narrowband signal as the LO, good mixer balance and the resulting suppression of the fifth order spurious can be achieved for all output frequencies.

As much as 20 dB improvement in fifth order spurious rejection resulted from this assignment of ports. However, it requires a 4-GHz amplifier. Fortunately, thin-film technology made it possible to get 20 dB gain at 4 GHz with a 4-stage linear amplifier which with a single output transistor achieves a gain-compression level of about $+17$ dBm, more than adequate to drive the mixer.

Wideband, Wide-Range Modulator

The modulator, another thin-film circuit, achieves a dynamic range of 60 dB. On all output level ranges below 1 volt, the output can be amplitude modulated up to 90%. The percentage of AM that is possible on the 1-volt output range is constrained, however, by the peak amplitude capability of the output amplifier and is thus inversely proportional to the setting of the output level vernier. (Note: the first

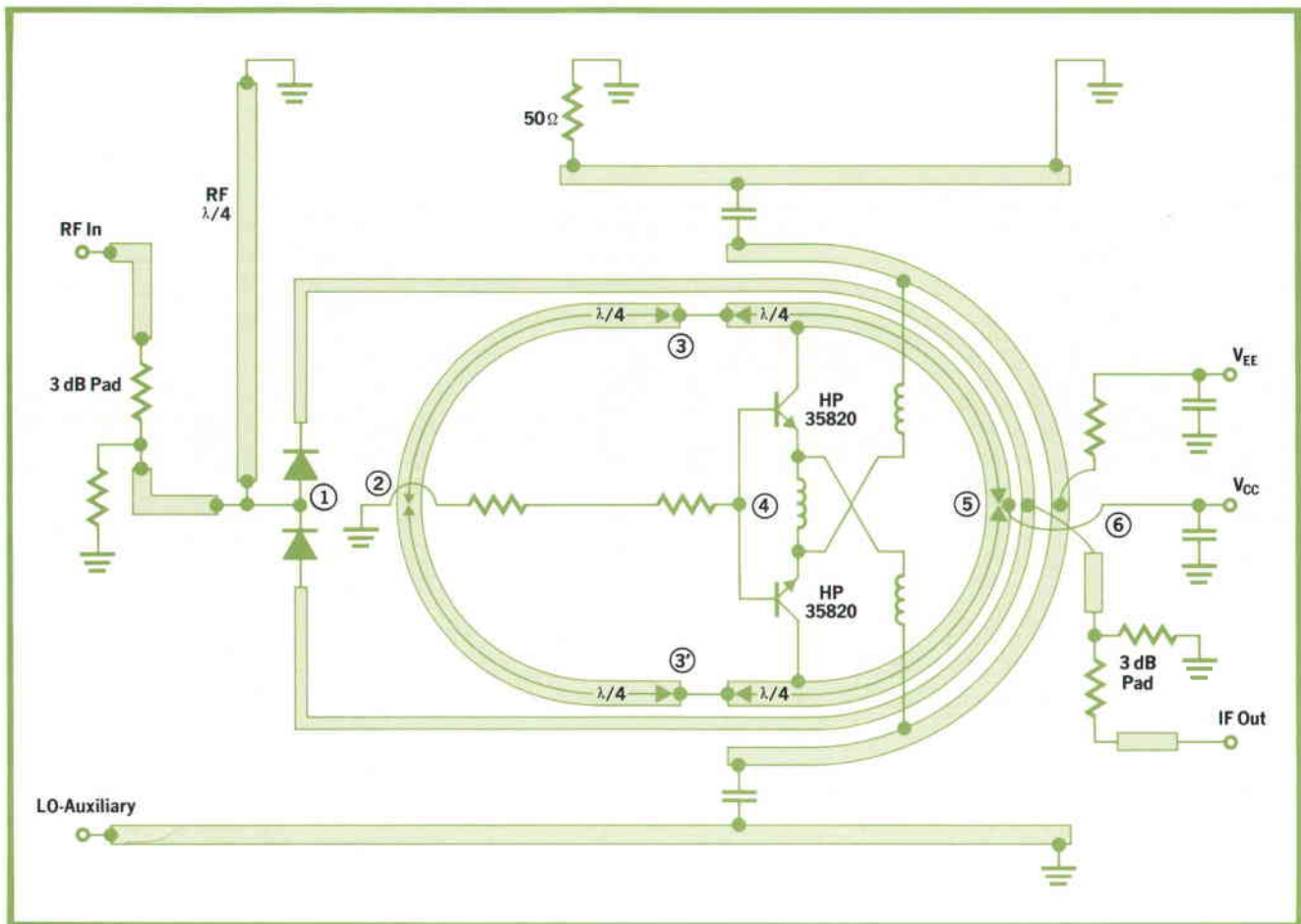

Fig. 9. Thin-film hybrid integrated circuit oscillator-mixer uses push-pull configuration and transmission-line coupling.

10 dB of attenuation is performed by the level control system; the remaining steps occur in the attenuator.)

Since the modulating bandwidth is 50 kHz, risetime during pulse modulation is limited to about 7 μ s. Faster risetime is possible, however, through use of a new Auxiliary Section (Model 86631B). This gives direct access to the modulator. When operated in the pulse mode, the Auxiliary Section opens the leveling loop and biases the modulator "off", suppressing the output more than 40 dB. A negative-going 10 V pulse into the Auxiliary Section turns the modulator fully on. Rise and fall times are then about 50 ns.

The modulator can be a source of phase noise because AM noise in the leveling loop can be converted to phase noise by the phase-shift vs attenuation characteristics of this device. As shown in Fig. 10, the modulator achieves a slope of typically only 1°/dB, considered a very low value in view of the wide dynamic range (60 dB) and frequency range. (2.7–4.0 GHz).

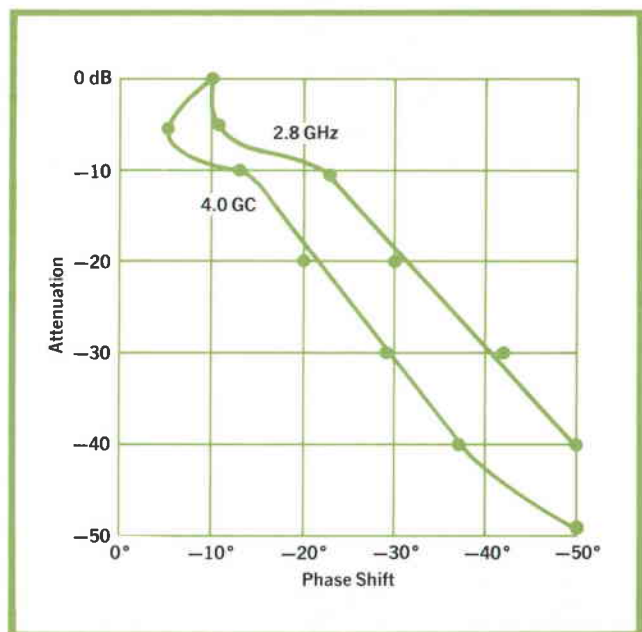

Fig. 10. Modulator phase shift as function of attenuation at both frequency extremes.

Printed-Circuit Mixer

The output mixer achieves desired performance with inexpensive packaged diodes and printed-circuit techniques. A diagram is shown in Fig. 11.

The mixer uses a transmission-line hybrid, or "rat race" as it is familiarly known, with Schottky-barrier diodes arranged in a "star" configuration. Because of the extra $\frac{1}{2}$ wavelength in the line, the LO signal at point A' is 180° out of phase with the signal at point A. The LO thus turns on the diode pairs, D1-D2 and D3-D4, alternately.

The RF signal is similarly introduced in push-pull at point B and B'. These points are nulls in the LO path.

Sum and difference frequencies are thus available at the diode junction, but the sum frequency is eliminated in a compact, thin-film, low-pass filter mounted on the back side at the junction point. Because the mixer output is available directly at the diode junction, conversion efficiency is high. Although the diodes are actually operating above their equivalent series-resonant frequency, the package parasitic inductance and capacitance, normally a disadvantage, provide an excellent filter for removing harmonics.

The diodes are well matched by a computer-controlled system that tests diodes and identifies those that should be grouped together. Excellent balance is maintained over a limited though adequate bandwidth. Design objectives called for spurious signals to be as low as possible on the 1-volt range and 70 dB down on all other ranges. (Note: the level con-

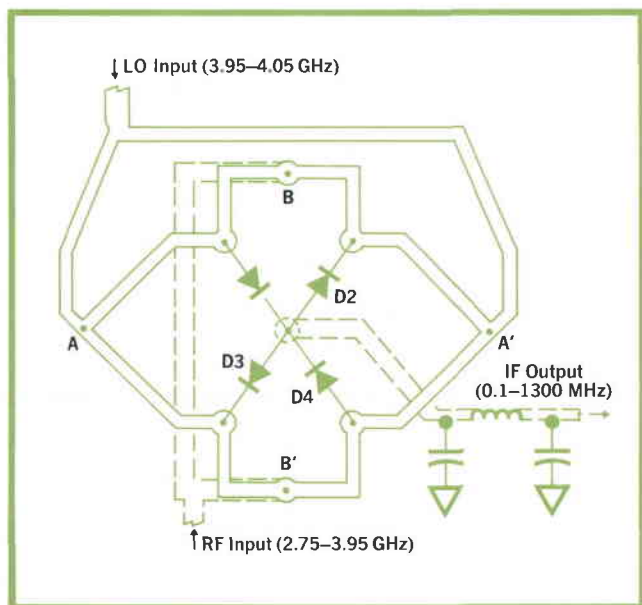

Fig. 11. Output mixer uses strip-line techniques on Teflon PC board sandwich with grounded center plane. RF input and IF output, shown dotted, are on back side.

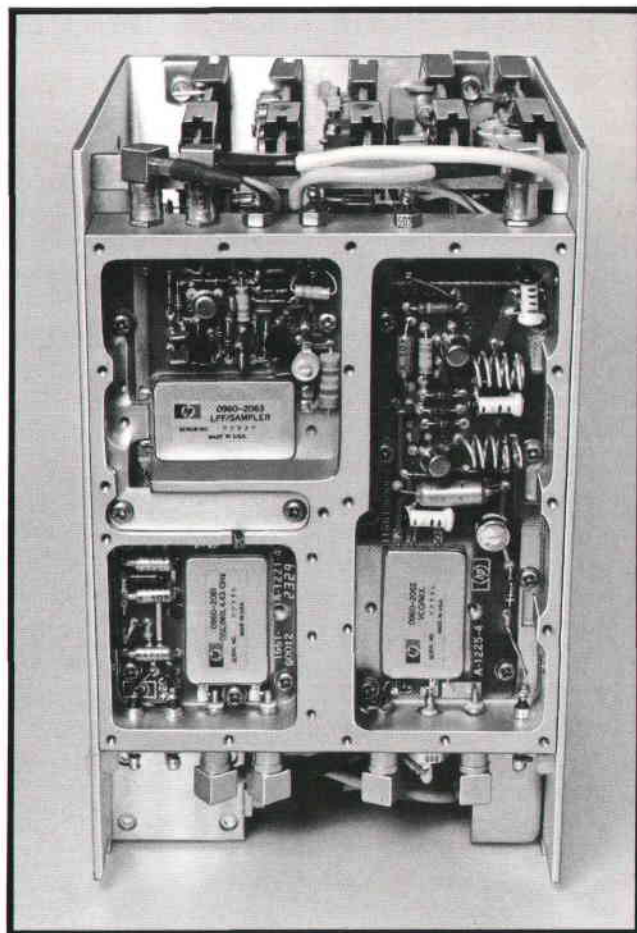

Fig. 12. Thin-film hybrid microcircuits (rectangles with HP insignia) are mounted in Frequency Extension Module on printed-circuit boards in same way as conventional components. Signal transfer in and out of microcircuits is by way of strip-line transmission lines, eliminating coaxial lines and space-consuming connectors. Electromagnetic isolation between circuits is provided by walls in solid metal casting.

trol system reduces the RF input to the mixer and output amplifier on all ranges below 1 volt.) The mixer easily meets this requirement, with spurious typically 65 dB down on the 1-volt range and much greater than 80 dB down on all other ranges.

Acknowledgments

Douglas Mellor contributed to the electrical design of the RF Section plug-in. Our thanks to Section Leader Wallace Rasmussen for help in product definition and to 8660A/B Project Leader John Shanahan for initial concepts.

References

1. J. C. Shanahan, "Uniting Signal Generation and Signal Synthesis," Hewlett-Packard Journal, December 1971.
2. J. E. Stinehelfer, "The Well-Modulated Synthesizer," Hewlett-Packard Journal, January 1972.

SPECIFICATIONS

HP Model 86602A RF Section

(in Model 8660A/B Synthesized Signal Generator with Model 11661A Frequency Extension Module installed)

FREQUENCY RANGE: 1.0 to 1299.999995 MHz. Selectable in 1-Hz steps. Usable down to 200 kHz with some degradation in specifications.

FREQUENCY ACCURACY AND STABILITY: determined by reference mainframe oscillator (3 x 10⁻⁴/24 hours) or by external reference if used.

SWITCHING TIME:

Largest Digit Changed	1 Hz 10 Hz	100 Hz	1 kHz 10 kHz	100 kHz 1 MHz	10 MHz	100 MHz 1 GHz
Error at:						
1 ms	<1 Hz	<100 Hz	<500 Hz	<500 Hz	<500 Hz	Undefined
5 ms	<1 Hz	<1 Hz	<10 Hz	<50 Hz	<50 Hz	<50 Hz

HARMONIC SIGNALS: All harmonically related signals are at least 30 dB below output signal for output levels below +3 dBm (-25 dBm for output levels above +3 dBm.)

SPURIOUS SIGNALS:

Below 700 MHz: -80 dB
Above 700 MHz: -80 dB within 45 MHz of carrier.
-70 dB greater than 45 MHz from carrier
(-50 dB on 1 V range).

Power Line Related: -70 dB

SIGNAL-TO-PHASE NOISE RATIO: Greater than 45 dB in a 30 kHz band centered on carrier excluding 1-Hz band centered on carrier.

RESIDUAL FM: <1.5 Hz rms in 2-kHz bandwidth centered on carrier.

SIGNAL-TO-AM NOISE RATIO: Greater than 55 dB in 30-kHz bandwidth centered on carrier.

Output Characteristics

OUTPUT LEVEL: Continuously adjustable from +10 to -146 dBm (0.7 V to 0.01 μ V rms) into 50 Ω resistive load. Output attenuator calibrated in 10-dB steps from 1.0 V (+13 dBm) full scale to 0.03 μ V (-137 dBm) full scale; vernier provides continuous adjustment between attenuator ranges. Output level indicated on output level meter calibrated in volts and dBm into 50 Ω .

OUTPUT ACCURACY (local and remote modes):

± 1.5 dB, +10 dBm to -76 dBm

± 2.0 dB, -77 dBm to -146 dBm

FLATNESS: Output level variation with frequency is less than ± 1.0 dB (typically ± 0.5 dB) 100 MHz to 1300 MHz.

OUTPUT LEVEL SWITCHING TIME: Any level change may be accomplished in less than 50 ms. Change to another level on same attenuator range may be accomplished in 5 ms in REMOTE mode.

IMPEDANCE: 50 Ω . SWR <2.0 on 1 volt and 0.3 volt ranges. SWR <1.3 on 0.1 volt range and below.

LEAKAGE: Meets radiated and conducted limits of MIL-I-4181D.

Modulation Characteristics

(With the 86632A AM/FM Modulation Section)

AMPLITUDE MODULATION:

MODULATION DEPTH: 0-90% on 0.3 volt range and below. (Modulation is possible on 1 V range depending on setting of vernier.)

RATE (at 30% depth): DC to 50 kHz above 10 MHz carrier frequency. DC to 4 kHz below 10 MHz. Rates at 90% depth are approximately 25 kHz and 2 kHz respectively.

CARRIER ENVELOPE DISTORTION (at 400 Hz and 1 kHz rates): approximately 1% at 30% depth, increasing to 5% at 90% depth. **INCIDENTAL FM:** 0.2 rad.

FREQUENCY MODULATION:

RATE: DC to 200 kHz

DEVIATION: DC to 200 kHz

INCIDENTAL AM: With 75 kHz peak deviation at 1 kHz rate, AM modulation sidebands are ≤ -60 dB.

DISTORTION: $\leq 2\%$

PULSE MODULATION (With the 86631B Auxiliary Section)

SOURCE: External.

ON/OFF RATIO: At least 40 dB (with modulation level control at max.).

RISE/FALL TIME: 50 nsec.

PRICES IN USA: 86602A RF Section, \$2800.
11661A Frequency Extension Module, \$2000.

MANUFACTURING DIVISION: MICROWAVE DIVISION, 1501 Page Mill Road, Palo Alto, California 94304

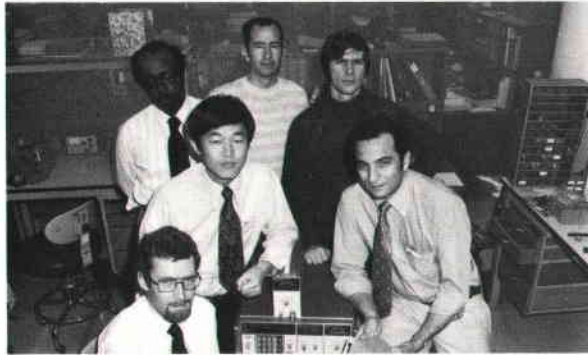

(Clockwise from lower left.)

Dieter Scherer

To get closer to the forefront of semiconductor technology, Dieter Scherer came to the U.S. and to HP in 1967, where he has been designing devices like the thin-film oscillators and amplifiers described in the article. Dieter has an Ing Grad. degree from the Oskar v. Miller Polytechnicum, A. Diplom Ingenieur in electronics from the Technische Hochschule, Munich, West Germany, and an MSEE acquired at Stanford under the HP Honors Co-op program.

Dieter and his wife like to explore the U.S. by car with their two sons (2 and 4), and they also enjoy concerts.

Young Dae Kim

Amateur radio led Young Dae Kim to a Korean first-class radio engineer's license and a BSEE at Seoul National University. He then worked as a microwave engineer and served as a communications specialist in the Korean Army.

Scholarships at South Dakota State University brought him to the U.S. for a MSEE (1969). Then it was HP and the YIG oscillator phase-lock loop. Kim is also pursuing a PhD at Stanford under the HP Honors Co-op program.

Married in the U.S. to a Japanese-Korean singer, Kim likes to play table tennis and oriental checkers.

Charles W. Cook

Starting as a test engineer with HP in 1967, Charles Cook soon moved on to product design, contributing to a number of microwave instruments. Charles has an AA degree in electronics from the City College of San

Francisco (he's a member of Phi Beta Sigma) and he has done further work at the University of California at Berkeley.

Although his family consists of wife and two daughters (10 and 14), Charles' outdoor activities have involved him in cub-scouting and the Big Brother program.

Melvin D. Humpherys

Born and raised in Wyoming, Dee Humpherys pursued academic degrees at Brigham Young University, earning a Bachelor's degree in Engineering Science and a MSEE (1964). He then joined HP in Palo Alto, working on the Model 606B Signal Generator, and on Microwave Spectrometers and Spectrum Analyzers before becoming project leader for the 86602A RF Section.

Married, and with three children ages 3 to 7, Dee has worked with youth groups, gets involved in church activities, and likes camping and water-skiing.

Bradley C. Stribling

Born in Canada, Brad Stribling moved with his family to the U.S. shortly thereafter. Brad worked as a technician and as a production engineer before going to the University of California at Berkeley for BSEE and MSEE degrees. At HP since 1967, he worked on the 5360A Computing Counter and several sections of the 8660A/B Synthesizers, including the VCO loop. He is working towards his PhD at Stanford under the HP Honors Co-op program.

Brad likes to back-pack, climb mountains, and ski.

Roland Hassun

A graduate of the Politecnico di Milano, Italy, Rolly Hassun also has an MSEE degree from San Jose State University. A 1958 summer employee at HP, he came back three years later, working on the 410C Voltmeter and then doing studies on transistor noise (HP Journal, March 1965). From there it was synthesizers, eventually becoming project leader for the 11661A Frequency Extension Module.

Rolly's family includes two girls, 11 and 12. He likes to play tennis but is also heavily involved in community affairs as a vice-president of the Peninsula Community Center.

A Greater Range of Capabilities for the Compact, Plug-on Digital Multimeter

Higher sensitivity for voltage and resistance measurements, 5-digit resolution, and a new "set range" concept are given the inexpensive 3470 Measurement System by new plug-on modules.

By Reid Gardner, Arthur Dumont, and Stephen Venzke

RECENTLY AN INEXPENSIVE THOUGH VERSATILE DIGITAL MULTIMETER system for bench and field use was described in these pages.¹ Of special importance, this measurement system (Hewlett-Packard Model 3470) promised expandability with a plug-together type of construction that let the user select an instrument configuration individually tailored to his needs.

This promise is being carried out with the development of two more plug-on modules (Fig. 1). One of these (the Model 34750A Display section) gives the system 5-digit resolution. The other (Model 37403A DCV/DCA/ Ω Meter section) gives several new capabilities, most notably higher sensitivity with 10-mV and 1-ohm full-scale ranges, and also self test, autoranging, and current measurements to as low as 1 μ A full scale.

Five-Digit Resolution

The new 5-digit Display section accepts a voltage in the range of ± 1.99999 volts from any of the input signal-conditioning sections, converts it into the equivalent digital number, and displays it on the 5½-digit LED numerical display (5 decimal digits plus a numeral 1 for 100% overrange readout).

The new Display section is compatible with all of the input and auxiliary sections already designed for the 3470 Measurement System, including the battery and BCD sections. One might well ask, then, what good is 5-digit resolution with input sections designed for 4-digit accuracy? The answer is: wherever measurements of small differences are needed—checking the effects of temperature or loading on circuit performance, for example, or finding which printed-circuit trace should be widened to reduce a current-induced offset in a high-gain amplifier, or tracking down a short circuit on a printed-circuit board by moving along a trace in the direction of decreasing resistance.

The key parameter here is linearity, as this is the determining factor in the usefulness of high resolution. The difference required to go from 0.99996 to 0.99997, say, should be the same as that needed to go from 0.90212 to 0.90213. High accuracy is needed only when the measurement must be related to an accepted standard, such as in calibration procedures. In view of the fact that many users want high resolution but prefer low price to high accuracy, the Model 34750A was not intended for use as a 5-digit calibrator. It can be useful, however, as a 4-digit calibrator where the 5th digit serves as a guard digit.

Although the 5-digit Display section uses the same dual-slope integration and auto-zero techniques as the Model 34740A 4-digit Display section described in the earlier article, it has more accurate and stable reference voltages. These give an overall accuracy specified as $\pm (0.025\%$ of reading $\pm 0.004\%$ of range) for dc voltage measurements.

Set Range

The most unusual capability provided by the new Model 34703A DCV/DCA/ Ω Meter section is the method of ranging. To begin with, autoranging is fast (< 10 ms per range) to protect the sensitive input circuits from unintentional overloads. However, protection provided by autoranging is carried over into the manual ranging mode. Even though set manually to a particular range, the instrument automatically upranges in case of an input overload, thus protecting the input circuits. What is more, it does not simply indicate that an overload condition exists, as is the usual practice, but it also displays the true value of the input, flashing the display to show that this is an overload. At the same time, it alternately flashes the two indicators that show the range on which the instrument is set and the range of the overload value, giving a clear indication of the magnitude of the overload. For this reason, the



Fig. 1. New modules for Model 3470 Measurement System, shown in center, give 5-digit resolution, higher sensitivity, autoranging and self test. Modules are compatible with units announced earlier so wider range of multimeter configurations, three of which are shown here, can be formed to meet various measurement requirements.

manual mode is referred to as the "set range" mode, to distinguish it from conventional manual operation.

Removing the overload restores the instrument to the selected range. However, if the operator should want to remain on the overload range, he merely presses the front-panel "Step" button, and the instrument automatically switches to that range.

This feature increases the usefulness of manual ranging. Manual range setting is often preferred when it is desired to give a readily grasped indication of how far from nominal a given value may be. It is also useful for maintaining maximum resolution around the range change point by preventing the instrument from upranging.

How the "set-range" concept enhances the usefulness of manual ranging can be illustrated by an example. Suppose the operator is using the instrument in the set-range mode for checking 10 Ω resistors, and suppose that in one batch of resistors there is a 10 k Ω resistor incorrectly marked as 10 Ω . When this resistor is connected to the instrument, the instrument automatically upranges, the display flashes, and the 10 k Ω and 10 Ω range lights flash alternately, immediately alerting the operator that an overload exists. At the same time, the display gives the true value of the resistor. Had the instrument been set to autorange, the operator might not have noticed that there had been a range change, and would have mistakenly passed the resistor as within tolerance.

A range is selected manually by pressing the "Step" button repeatedly—the instrument steps down one range each time the button is pressed until it reaches the lowest range. From there it steps to the highest range. As mentioned before, it can

also be set by pressing the "Step" button while the instrument is in overload with an input connected.

Fast autoranging is achieved by use of analog level-detect circuits to sense when the input goes 220% above full scale or below 15%. These circuits initiate a range change without waiting for the digital circuits to run through a full count, the usual practice. After the analog circuits have selected an appropriate range, the digital circuits then make a final correction, if needed. For example, if the input were between 200 and 220% of full scale on the final analog range change, the digital circuits would initiate one more uprange.

This arrangement assures that the instrument will present the measured value with maximum resolution in almost all cases. For example, if the final analog range change were downwards to between 19 and 15% of full scale, the digital circuits would step the instrument to the next lower range. Only if the final analog range change were downwards to between 20 and 19% of full scale would the instrument not present the measured value with maximum resolution.

Self Test

The autoranging system is controlled by a read-only-memory-driven sequential machine within the DCV/DCA/ Ω Meter section. It is similar to that described for the HP Model 3490A Digital Multimeter.² The use of this device also makes it possible to include self-testing capabilities in the DCV/DCA/ Ω Meter.

Self test quickly verifies that the instrument is operating correctly, and it is also useful during troubleshooting procedures. The various tests check

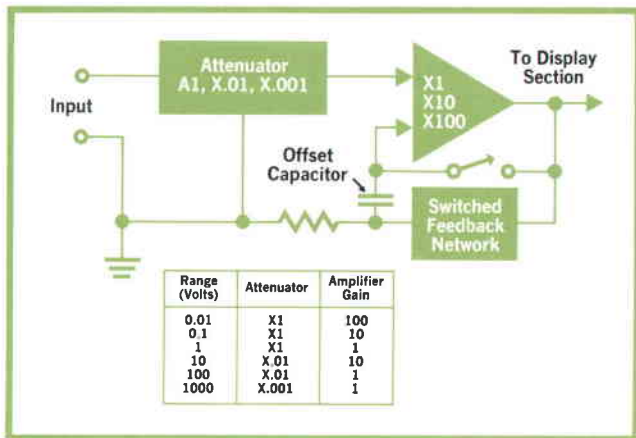

Fig. 2. In voltmeter mode, attenuator and amplifier scale input to voltage between -1.99999 and $+1.99999$ for digital presentation by Display section.

for leakage in the input circuits, the protection circuits, and in the attenuator switching FET's. Other tests check the auto-zero function of the input amplifier, the ohmmeter current source, and the ammeter circuits. One test actually is an automatically sequenced series of tests that verifies correct operation of 80% of the logic and display circuits. A pullout card explains the tests and what the resulting digital display for each means.

There are 16 test selections in all, 8 with the "Range" switch set on "Manual", and 8 with it set on "Auto". Tests are selected by pressing the front-panel "Step" button once for each new test. The range indicators show which test is selected.

Sensitive DC Voltage Measurements

The high sensitivity of the Model 34703A is obtained with a hybrid integrated circuit amplifier that has a switched feedback network for establishing gain. Three levels of gain (x1, x10, x100) are used in conjunction with the 3-step attenuator (x1, x0.01, x0.001) to give six voltage ranges from 10 mV full scale to 1000 V in decade steps (Fig. 2). All ranges go to 100% above full scale (e.g., to ± 19.9999 V) except for the top range which is limited to 1200 V.

The thin-film resistors in the feedback network are trimmed within 0.01% by a computer-controlled laser beam, so no gain-adjusting potentiometers are needed (the only adjustment provided is one for dc offset). Accuracy is enhanced by use of the auto-zero technique in which the input is shorted momentarily just prior to the measurement cycle.¹ While the input is shorted, any offset at the amplifier output is stored on a capacitor. This voltage is applied to the amplifier inverting input during the measurement cycle, canceling out the offset.

The DCV/DCA/Ω Meter section can be used with either the 4- or the 5-digit Display sections but if used with the 5-digit Display section, it blanks the least significant digit when switched to the 10 mV range. Practical limitations on noise would make higher resolution meaningless on this range. The 5th digit is also blanked on the 1 Ω resistance range and on all current ranges.

Autoranging Milliammeter

To function as a milliammeter, the instrument uses resistive shunts to derive a voltage proportional to current. As shown in Fig. 3, three shunts are used to give six ranges, from 1 μA full scale to 100 mA. Among other uses, the 0.1-nA resolution provided by the most sensitive range is useful for checking leakage currents in many kinds of solid-state devices.

A problem often arises in autoranging ammeters during the short time intervals when no ammeter shunt may be connected. If the current is supplied by a "stiff" current source, voltage transients high enough to damage the user's circuit, and possibly the ammeter itself, may be generated.

This problem was avoided by the use of clamp diodes, as shown in Fig. 3. These conduct whenever the voltage at the input rises above a few volts, bypassing the current.

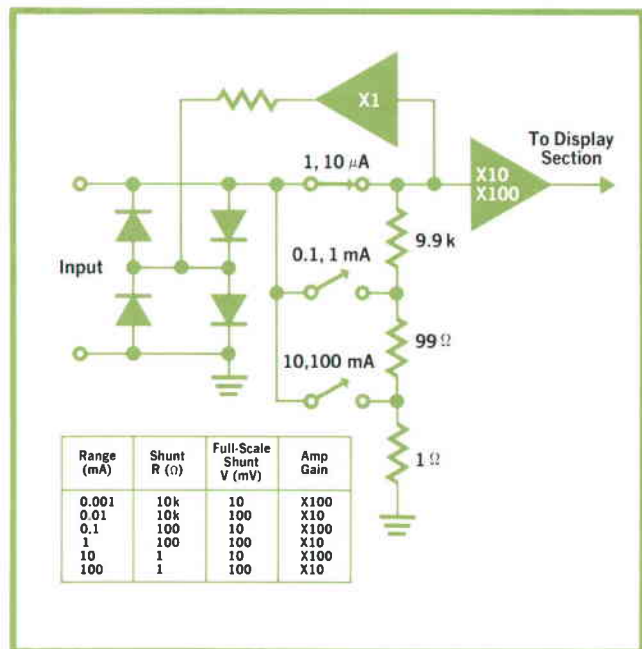

Fig. 3. In milliammeter mode, shunt resistors develop voltage proportional to current for measurement by Display section. Diodes bypass current at times range switches may be open during ranging. During measurement, upper pair of diodes are boot-strapped to current-derived voltage to prevent leakage of current around shunts.

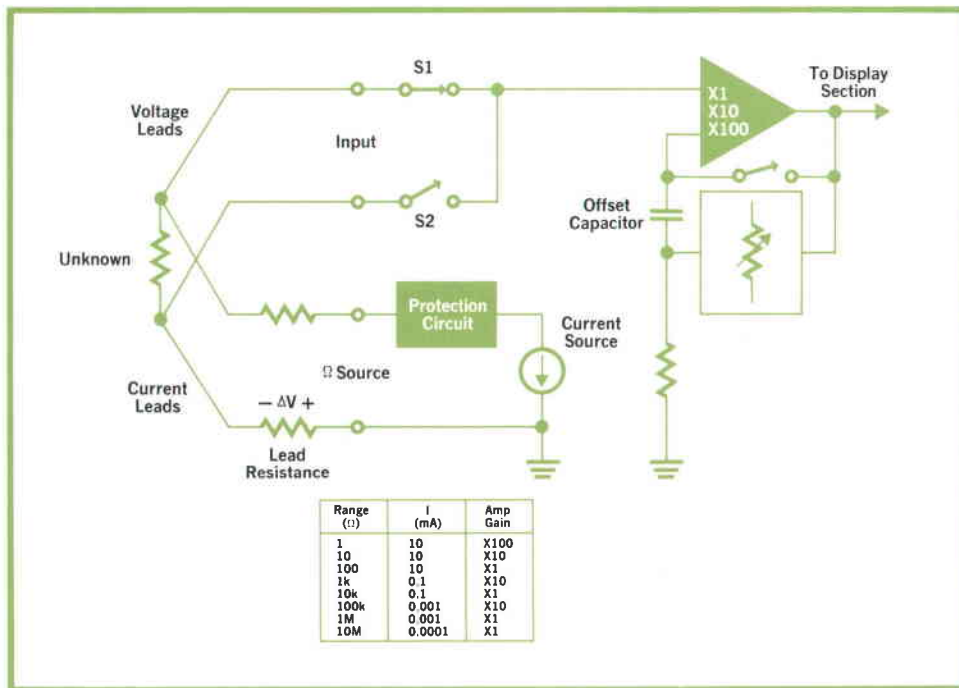

Fig. 4. In ohmmeter mode, current through unknown develops voltage proportional to resistance for measurement by Display section. Just prior to measurement cycle, S1 opens and S2 closes. Voltage ΔV resulting from current through lead resistance is stored on offset capacitor. During measurement, offset voltage is subtracted from measurement voltage, eliminating effect of lead resistance on measurement.

Precision Ohmmeter

Resistance measurements are made with a 4-terminal technique which, by eliminating current-induced voltage drops in the measurement leads, makes a 1 Ω full-scale range practical. This provides 0.1-milliohm resolution, useful for contact resistance and other "short-circuit" measurements. Eight resistance ranges are provided, giving a maximum range of 10 M Ω (to 20 M Ω with 100% overranging).

Four-terminal measurements are made by supplying the current for the measurement through a set of leads separate from those that carry the voltage developed across the unknown back to the instrument. Any voltage drops in the current-carrying leads thus do not enter into the measurement. Customarily, the current is supplied by a floating power supply so that the lower end of the unknown can be grounded for the voltage measurement.

A lower cost way of providing 4-terminal measurements is used in the new DCV/DCA/ Ω section by taking advantage of the autozero technique. As shown in Fig. 4, any voltage drop across the current-carrying lead is included in the voltage stored on the offset capacitor, so it is effectively canceled out during the resistance measurement. This arrangement does away with the need for floating the current source.

The current source is protected against accidental application of external voltages up to ± 350 V to the front-panel Ω source terminals.

Acknowledgments

Thanks are due Jim Ressmeyer for development of the hybrid circuit that includes the reference voltages. The authors are also indebted to Mike Williams and Dennis Colman for the product designs, but whose efforts extended far beyond. Much helpful advice was provided by DVM Group Leaders Lee Thompson and Al Gookin. 

References

1. A. Gookin, "Compactness and Versatility in a New Plug-Together Digital Multimeter," Hewlett-Packard Journal, August 1972.
2. L. Thompson, "A New Five-Digit Multimeter That Can Test Itself," Hewlett-Packard Journal, August 1972.



SPECIFICATIONS
HP Model 34703A DCV/DCA/Ω Meter
 (With either Model 34740A 4½-digit
 or Model 34750A 5½-digit Display Sections.)

DC Voltage

RANGES: ±10 mV to ±1 kV in decade steps, auto or manual.
 OVERRANGING: 1 kV range: 20%. All others: 100%
 ACCURACY: (30 days, 23°C ±5°C):

RANGE	10 mV	100 mV	1 V	10 V	100 V	1 kV
With 34740A (displays up to 19999)	±(0.03% of reading ±0.03% of range)	±(0.03% of reading ±0.01% of range)	±(0.04% of reading ±0.02% of range)			
With 34750A (displays up to 199999)	±(0.025% of reading ±0.025% of range) (last digit is blanked)	±(0.025% of reading ±0.004% of range)	±(0.035% of reading ±0.01% of range)			

INPUT RESISTANCE:	≥10 Ω	10 MΩ ± 1%
-------------------	-------	------------

COMMON MODE REJECTION: > 120dB
 NORMAL MODE REJECTION: > 60dB

DC Current

RANGES: ±1 μA to ±100 mA in 8 decade steps, auto or manual.
 OVERRANGING: 100% on all ranges
 ACCURACY: (30 days, 23°C ±5°C):

RANGE	1 μA	10 μA	100 μA	1 mA	10 mA	100 mA
With 34740A	±(0.08% of reading ±0.03% of range)				±(0.27% of reading ±0.03% of range)	
With 34750A (last digit is blanked)	±(0.075% of reading ±0.025% of range)				±(0.27% of reading ±0.025% of range)	

INPUT RESISTANCE:	10 kΩ	100 Ω	1 Ω
-------------------	-------	-------	-----

Ohms

RANGES: 1 Ω to 10 MΩ in 8 decade steps, auto or manual.
 OVERRANGING: 100% on all ranges.

ACCURACY (30 days, 23°C ± 5°C):

RANGE	1 Ω	10 Ω	10 kΩ	100 kΩ	10 MΩ
With 34740A	±(0.05% of reading ±0.03% of range)		±(0.05% of reading ±0.01% of range)		±(0.12% of reading ±0.01% of range)
With 34750A	±(0.045% of reading ±0.025% of range) (last digit blanked)		±(0.045% of reading ±0.005% of range)		±(0.12% of reading ±0.004% of range)
STIMULUS:	10 mA	100 μA	1 μA	0.1 μA	

General
 (Meter and Display sections together)

OPERATING TEMPERATURE: 0 to 50°C
 POWER: 100/120/220/240V -10%, +5%, switchable; 48-440 Hz;
 ≤ 8.7 VA
 DIMENSIONS: 8½ in. W x 3¾ in. H x 9¾ in. D (160 x 98 x 248 mm).
 WEIGHT: 5 lb. (2.26 kg)
 PRICES IN U.S.A.: 34703A DCV/DCA/Ω Meter, \$550.
 34750A 5½-digit Display, \$550.

MANUFACTURING DIVISION: Loveland Division, 815 Fourteenth Street, S. W., Loveland, Colorado 80537



Arthur J. Dumont (RIGHT)

Art Dumont was an electronic technician with the U.S. Navy, then left after 5 years to work as a tech writer and customer engineer before going on to college (BSEE and MSEE, University of Wyoming, 1970). Then it was HP and the 3470 Measurement System, including the 34750A Digital Display.

Art and his family (three children ages 2, to 5), enjoy living near a lake where Art keeps and sails a boat.

Stephen B. Venzke (LEFT)

Joining HP in 1965, Steve Venzke initially worked as a circuit designer (function generators) and as a production engineer. Later, he worked on the 3320/30-A/B Synthesizers and then the 34703A DCV/DCA Meter plug-on. He holds a BSEE degree from the University of Minnesota and earned a MSEE at Colorado State under the HP Honors Co-op program.

Married, but with no youngsters, Steve works with church-sponsored youth activities, as well as enjoying the Colorado outdoors (fishing, backpacking, etc.).

Reid J. Gardner (CENTER)

Reid Gardner joined HP in 1963 after taking his MSEE at Utah State. He worked on distortion analyzers, then became project leader for the 400E AC Voltmeters. Next he started up the Loveland Division IC facilities, then returned to the lab as project leader on the 3431A Digital Panel Meters and on the 34703A DCV/DCA/Meter plug-on, doing the digital portion.

Reid lives on a 10-acre ranch that keeps his six children, ages 1½ to 4, busy raising livestock. Church and school activities occupy any free time left.

Address Correction Requested:

Hewlett-Packard Company, 1501 Page Mill Road, Palo Alto, California 94304

Bulk Rate
 U.S. Postage
 Paid
 Hewlett-Packard
 Company

HEWLETT-PACKARD JOURNAL

MARCH 1973 Volume 24 • Number 7

Technical Information from the Laboratories of
 Hewlett-Packard Company

Hewlett-Packard S.A., CH-1217 Meyrin 2
 Geneva, Switzerland
 Yokogawa-Hewlett-Packard Ltd., Shibuya-Ku
 Tokyo 151 Japan

Editorial Director • Howard L. Roberts
 Managing Editor • Richard P. Dolan
 Contributing Editors • Ross H. Snyder,
 Laurence D. Shergalls

Art Director, Photographer • Arvid A. Danielson
 Art Assistant • Erica R. Helstrom
 Administrative Services • Ruth G. Palmer

CHANGE OF ADDRESS: To change your address or delete your name from our mailing list please send us your old address label (it peels off). Send changes to Hewlett-Packard Journal, 1501 Page Mill Road, Palo Alto, California 94304 U.S.A. Allow 60 days.

HP Archive

This vintage Hewlett-Packard document was
preserved and distributed by

www.hparchive.com

Please visit us on the web!

On-line curator: John Miles, KE5FX

jmiles@pop.net

