

A "Voltmeter" for the Microwave Engineer

It makes swept insertion and return loss measurements simultaneously, over a wide frequency range.

by Hugo Vifian, Frank K. David, and Wayne L. Frederick

TO THE MICROWAVE ENGINEER, an instrument that measures insertion and return loss simultaneously, over a broad band, would be as useful as is the voltmeter to other electronic specialists, provided it is made practical in several important ways.

- Its measurements must really refer to the microwave measuring port, not just to the output of some RF converter.
- Stability and repeatability of the measurements should be so good the meter can properly be called driftless.
- Broad frequency range is necessary, but it must be accompanied all the way by adequate accuracy and dynamic range, yet drive requirements should be low.
- Compactness is desirable, and price must be in line.

The effort to achieve all those desiderata resulted in a new instrument (Fig. 1) that makes several contributions. The block diagram (Fig. 2) shows how elements of the new Model 8755 Frequency-Response Measuring System work together. The swept RF output of the microwave source is simply on-off amplitude-modulated at a 30-kHz rate by the Modulator, before it is applied through the directional detector to the device to be tested. Three identical Schottky-barrier diode detectors sense the incident, reflected, and transmitted RF waves at the network ports and convert each into a 30-kHz squarewave by envelope detection. The amplitude of the squarewave will be shown to be a measure of the microwave signal at the various ports. It is this low-frequency signal that is processed to display insertion loss or return loss in dB/div on the

CRT of the oscilloscope into which the 8755A Analyzer is plugged. The 'scope may be any of the HP 180 series.

Schottky-Barrier Diode as RF Converter

Preliminary work showed that only a biased Schottky-barrier diode could yield enough signal-to-noise ratio, at -50 dBm, across the bandwidth needed in the planned swept displays. Desirable as this high sensitivity is, the biased diode scheme

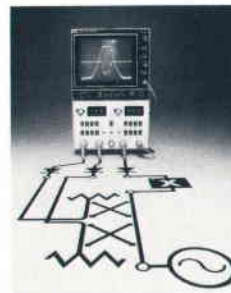

Cover: *Simultaneous swept-frequency display of insertion and return losses speeds up adjustments for optimum performance in a tested device, one of the measurement conveniences provided by HP's new "voltmeter for the microwave engineer," described in the article beginning on this page. Working in any 180-series Oscilloscope, this new plug-in presents two amplitude-response characteristics of unknowns over a frequency range that extends up to 18 GHz.*

In this issue:

A "Voltmeter" for the Microwave Engineer, by Hugo Vifian, Frank K. David, and Wayne L. Frederick . . . **page 2**

Versatile Display Unit Extends Correlator Capability, by David J. Morrison, Brian W. Finnie, Rajni S. Patel, and Kenneth H. Edwards . . . **page 8**

Voltage Precision and High Current Capability—Both in One Power Supply, by George G. Emmermann . . . **page 16**

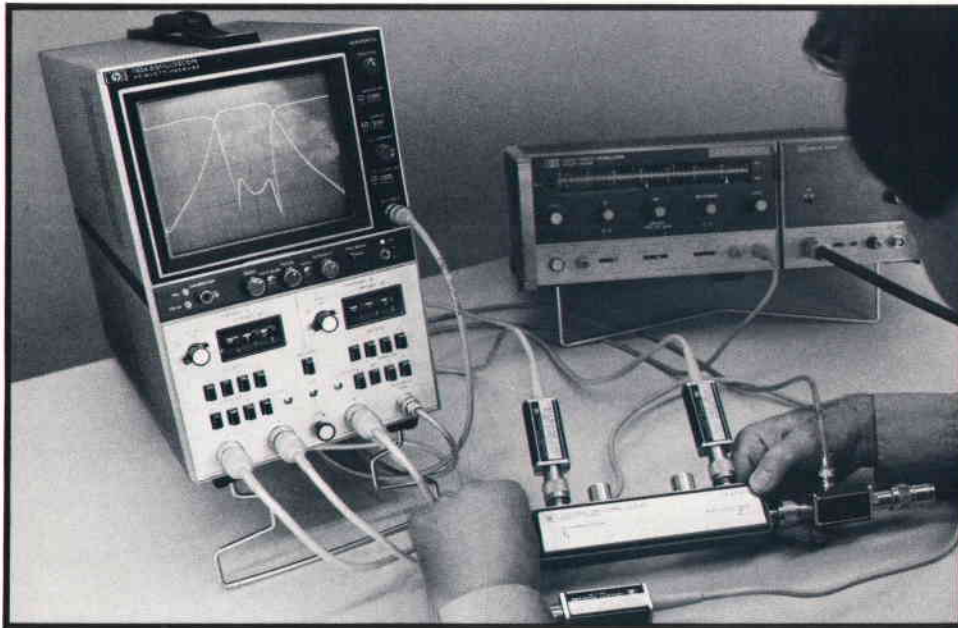

Fig. 1. Swept-Frequency Response Measuring System analyzes amplitude-response characteristics of unknowns over frequency range 100 MHz to 18 GHz. Results appear on CRT. Since two traces may be seen at once, system can simultaneously show insertion loss on one trace, return loss vs. frequency on the other.

nevertheless has a drawback. The signal that results from the detected microwave power appears in series with the bias-caused forward voltage drop of the diode. Fluctuations of this forward voltage due to temperature and device variations are several orders of magnitude greater than the desired signal when at its lowest useful levels, around $5 \mu\text{V}$. So it becomes almost impossible to process the RF-derived signal on a dc basis.

It is the modulation scheme that makes possible a virtually driftless measurement, while also obtaining high sensitivity. Detected, the envelope of the RF component becomes an ac signal which can readily be separated from the dc component. Un-

fortunately, the detected signal amplitude is also a function of the index of modulation. It is therefore essential to keep the index constant, regardless of source power. This can reliably be achieved by on-off (squarewave) modulation of the microwave signal. The peak-to-peak amplitude of the detected signal then also becomes a measure of the absolute power level seen by the diode detector, and the 8755A system thus may also be used as a calibrated power meter.

Dynamic Range

A detection scheme with dynamic range of 60 dB (from +10 to -50 dBm) at the RF port may not

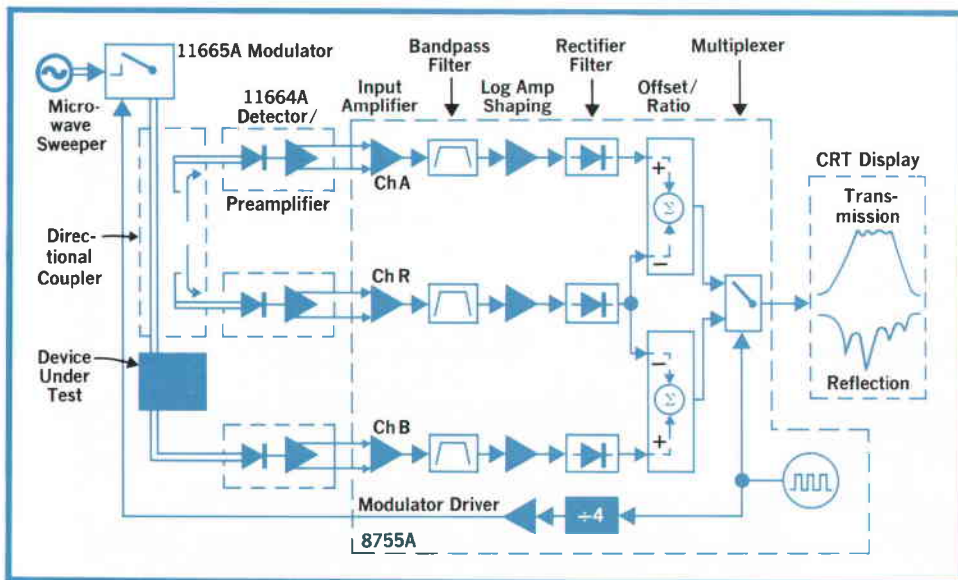

Fig. 2. 8755 System block diagram. 60-dB display may be had with only 10 mW drive, so modern solid-state sweepers are entirely compatible. Detectors are broadband; active bandpass filter removes unwanted frequency components outside 10 kHz band centered on modulating frequency.

Evolution of a Diode Detector

The diode detector for a network analyzer might be looked upon as a product of its "environment," evolving naturally therefrom. To survive as a final choice, the detector had to meet many and sometimes contradictory requirements. 1) Dynamic range from -50 to $+10$ dBm calls for tangential sensitivity* beyond -50 dBm (in a 30-kHz band) and burnout level above $+10$ dBm. 2) Bandwidth 0.1 to 18 GHz, with extension downwards desirable. 3) Consistent amplitude response from detector to detector—tracking error between any two under 0.25 dB over the whole dynamic range, and all detectors having low-level sensitivity (γ) within a 0.5-dB window. 4) Frequency response of all detectors not necessarily flat, but the same, within 1.25 dB, across the full band. 5) Response variations with temperature as low as possible. 6) Low reflections from the detector, i.e. good match. 7) Low cost, small size, and field reparability.

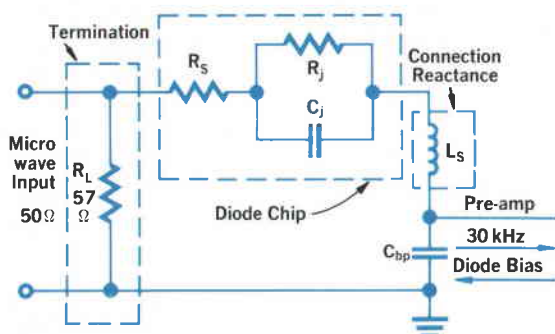

Fig. 1

The choice of diode type narrowed early to the Schottky barrier. The burnout level of the "back" diode is too low; the point contact diode flunks both on dynamic characteristics and on diode-to-diode variation. The Schottky barrier diode has been proved uniform, and its TSS exceeds -53 dBm, but it must be biased if its γ is not to be zero. When biased there is a voltage drop across it (200 to 400 mV), and while that hinders its use as a microwave CW detector, on-off modulation solves the difficulty (see text).

As a first step in meeting the match requirement, the incoming microwave line was terminated (R_L in the equivalent circuit, Fig. 1; a blocking capacitor, not shown, confines bias to the diode). It is possible to set bias current so the diode has 50 ohms dynamic impedance, but only below -20 dBm; above that the detected signal starts to "re-bias" the diode. The value of the termination is a compromise at 57 ohms, forming a reasonable match when in parallel with a diode whose dynamic impedance varies with signal level.

Since the diode sees the same voltage on the microwave

*Tangential Sensitivity (TSS) is defined as the peak microwave power (in dBm) at the diode's input that gives, at the diode's output,

$$20 \log \frac{\text{Peak detected voltage}}{\text{rms noise voltage}} = 8 \text{ dB}$$

for any given noise bandwidth. When an rms ac voltmeter is used as the I.F. detector, TSS is the peak power necessary to raise the output 4.1 dB above the rms noise voltage.

line that the termination sees, and since it follows the so-called "square law" through much of its range, the detected output is proportional to the *square* of the voltage across the termination, and therefore it is a measure of the *power* delivered to the termination.

Thin-Film Hybrid Microcircuit

The circuit has been realized in hardware by thin-film hybrid microcircuit techniques, which gave the necessary high degree of circuit-to-circuit uniformity while achieving the design parameters.

Even though flat response is not necessary, it is nevertheless desirable; the flatter the response, the easier it will be to meet tracking requirements. A posteriori knowledge and circuit analysis revealed that the detector's frequency response is greatly influenced by connection reactance (L in the diagram), the composite of reactances resulting from mounting and connecting the diode chip to the microwave line, in this case a microstrip. (The same would be true, of course, for such other types of lines as coax or stripline.) The reactance has all the first-order effects of a series inductor. If response is to be reasonably flat to 18 GHz its value must be both small and well controlled. It turns out that connection reactance is not simply and directly a function of the length of the bonding wire, as simple inspection might suggest; it is also a function of the geometry of the interacting electromagnetic fields in the structure. The diode must effectively shunt the line, and shunt elements are difficult to fabricate when the line and its ground plane are separated by a sapphire substrate. The practical solution is shown in Fig. 2.

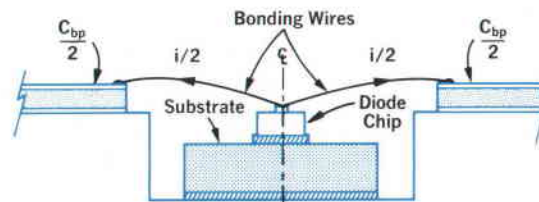

Fig. 2

Connection reactance is reduced in two ways: 1) the design makes it possible to keep the dimensions of the substrate and the spacing of the capacitors at a minimum, and 2) the opposing directions of the current around the paths from bonding wire pads to ground plane give some cancellation of the magnetic fields, so flux density (in this structure one direct contributor to connection reactance) over any portion of the surface is reduced. The inductive term in connection reactance is, to the first order at least, controlled in this configuration by the geometry of the system; thin-film hybrid construction, with its characteristically tight dimensional controls, thus is ideal for the purpose.

The same balancing of the connection to shunt elements on microstrip is applicable to construction of a well-behaved termination. The arrangement is shown in Fig. 3. From dc to beyond 18 GHz, this termination is free of the series inductive reactance that has been the nemesis of microstrip terminations.

continued

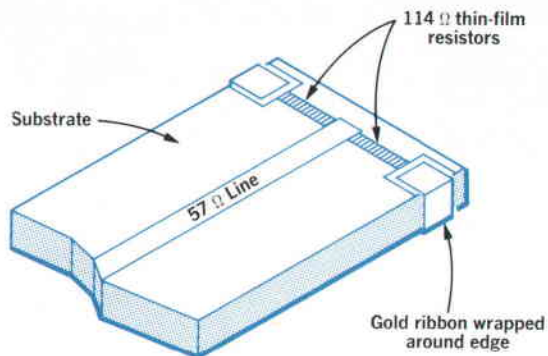

Fig. 3

With the inductive element under some measure of control the only troublesome parasitic element left is the capacitance component in the diode chip, C_j in Fig. 1. Its value in a Schottky-barrier diode biased at $100 \mu\text{A}$ is in the range 0.1 to 0.13 pF, which must be reduced if the detector is to

attain the desired frequency response and termination characteristics. While nothing can be done directly with the capacitance inherent in the chip, the substrate can be modified to reduce its effect. Removal of the ground plane immediately below the point where the diode rests on the line reduces the effect of chip capacitance satisfactorily. The remaining effective value was incorporated as one of the shunt capacitances in a low-pass filter/matching structure, an often-used stragem which is effective to 18 GHz here because the effective capacitance of the chip has been made sufficiently low.

The final step in adapting the detector to its purpose was inserting a preamplifier between the output of the detector and the input of the analyzer. The amplifier provides current bias to the diode, and a voltage gain of 4 (but a power gain of more than 200). It comprises a buffer stage easily able to deliver a large, fast voltage swing to a capacitive load. The only stringent requirement was that the amplifier could not degrade the tangential sensitivity of the diode, while at the same time it had to be a low-noise amplifier that handles large signals.

—Frank K. David

sound impressive until it is realized that the Schottky-barrier detector used to down-convert the microwave signal to dc (ac in our case) follows the so-called "square law" at the lower input levels. This means that each 10 dB of dynamic range at the RF port requires us to deal with 20 dB of detected signal range. That leaves us theoretically with more than 120 dB of signal variation to process accurately in one single range. To measure low-level RF signals accurately—signals as low as -50 dBm yielding detected signals as low as $5 \mu\text{V}$ —it is necessary not only to have good noise performance in the input amplifiers, but also to obtain considerable rejection of common-mode signals, and to achieve high isolation among the three measuring channels. As the block diagram (Fig. 2) shows, the detected signal is preamplified and buffered in the Schottky-barrier diode probe, then brought at low impedance to the actual measuring instrument, which has high common mode rejection in its input stage.

Signal Shaping in the Logarithmic Amplifier

Since the conversion characteristic of the diode detector is not a linear function of the input signal over the entire dynamic range to be served, it is necessary to compensate for signal compression at the higher levels to obtain linear overall response. This correction is accomplished in the logarithmic amplifier by shaping its response to high-level signals in accord with the Schottky-barrier diode compression characteristic as shown in Fig. 3. The output of the logarithmic amplifier now is a signal proportional to the absolute microwave power (in dBm) seen by the detector. The basic logging circuit

is similar to the one used in the HP Model 3570A Network Analyzer, described in last month's Hewlett-Packard Journal. The logarithmic relation between the base voltage and the collector current of a differential pair is used over approximately 10 dB of signal range. Twelve pairs are fed in parallel by signal levels spaced 10 dB apart, from a voltage divider for high levels, and from a chain of four amplifiers for the low signal levels. The currents in the high-level stages are increased to compensate for signal compression in the detector. Because all

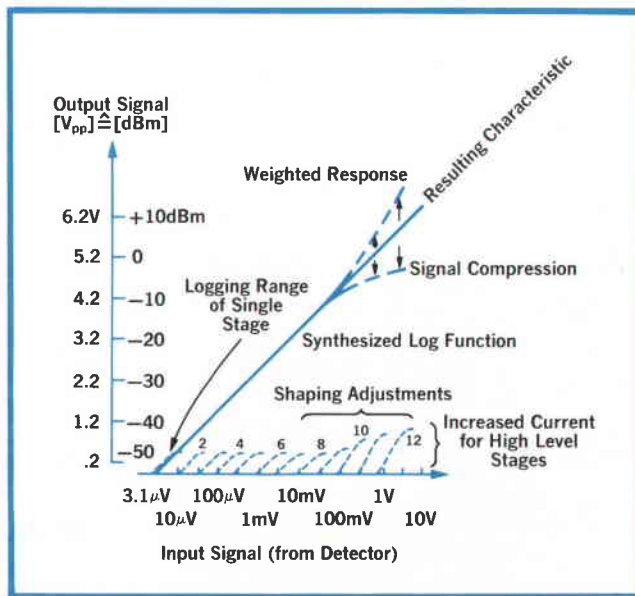

Fig. 3. Signal shaping produces linear response over 60-dB range.

The Well-Matched Modulator

A key element in the performance of the 8755A Swept-Frequency Response Measuring System is the modulator.

The Modulator (Model 11665A) is a two-state absorptive type, operating with a single current drive. It divides naturally into three sections, a blocking capacitor, an operational module, and a 100-MHz high-pass filter. Blocking capacitors of the disc ceramic type are found on each end of the modulator. The operational module is a hermetically-sealed PIN-diode absorptive switch. The 100-MHz high-pass filter is a three-element Chebyshev design. The filter is necessary to prevent the modulation drive from being applied to the RF line; without the filter the drive feedthrough could be as high as one or two volts, which would show up as an increase in system noise level, and it would also decrease the instrument's dynamic range. It could, of course, change the bias level of active devices in the tested network, or even destroy them.

Reflective modulators were ruled out for several reasons. When the match changes rapidly from 50 ohms to a short circuit, the leveling loops in many sweep generators are not fast enough to keep the power leveled. Under these conditions a grid-leveled BWO generator, operating at low level, could easily be pulled out of oscillation. The effect of such changes on the device under test may also be undesirable. A transistor amplifier, for example, could oscillate when the modulator goes to a short, and the circuit may not have time to stabilize before the measurement is made.

The modulator is shown in the schematic here. It operates normally in two states: low loss (+50 mA) and high loss (-50 mA). During the transition between states the match gets no worse than 3:1 VSWR and the insertion loss at zero current is about 6 dB. This occurs when all the diodes are off, leaving only the two 47-ohm resistors in series with the load.

In the low-loss state, the series diodes are conducting,

while the two shunt diodes are back-biased. The series diodes bypass the 47-ohm resistors; the shunt diodes are out of the circuit except for their capacitance, which is part of a low-pass filter. The result is a low-loss path through the module.

In the high-loss state, the shunt diodes are biased through R1. The voltage developed across this resistor back-biases the one series diode, D1. The other series diode, D4, is not back-biased but its barrier potential is sufficient that the RF signal cannot forward-bias the diode. At that diode the RF signal is low because the module is in its high loss state. The series diodes being effectively out of the circuit, the 47-ohm resistors now are grounded through the shunt diodes, and the circuit presents a good match.

The control current is not critical because the diodes are being used as switches, not as variable resistors as in some absorptive modulators.

The main problem in realizing the 100-MHz high-pass filter was to develop an inductor having a particular desired value without substantial resonances from dc to 18 GHz. One way to accomplish this would be a spiral inside the coaxial line. If the turns are perfect rings around the center conductor there will be no coupling to the field; such coupling can be minimized by keeping small the increase in diameter of each turn. The effect of the resonances in the coil can further be reduced by using resistive wire, which also reduces the transmission losses. The resistance value of the wire is somewhat critical, since a value too high would degrade cutoff response of the filter. Resistance of the inductor finally used is about 3 ohms, introducing a maximum transmission loss of about 0.25 dB due to the resonances. Using these filters in the modulator, and the drive from 8755A, the modulation drive feed-through is a short pulse of energy—less than 1 μ V rms.

—Wayne Frederick

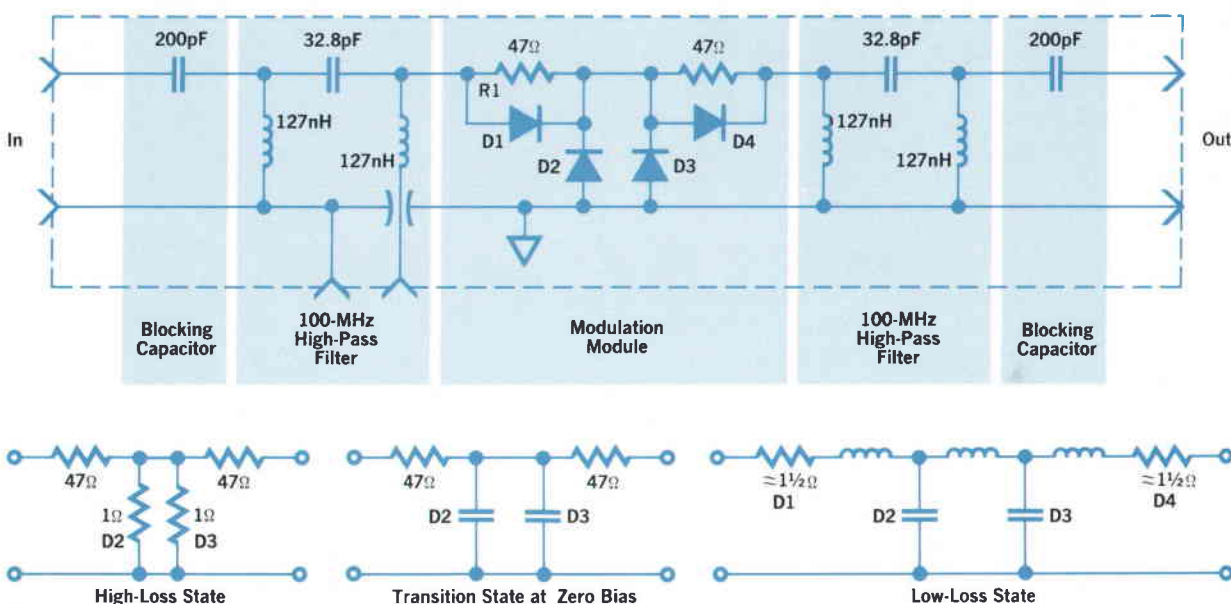

the twelve logging elements are one monolithic structure, cyclic ripple is small and overall accuracy is good—less than 1 dB error over a 100-dB range is typical.

The signal that results from logarithmic compression has a variation of less than 30 dB over the instrument's full dynamic range; thus it can easily be rectified for further processing and display.

Three Identical Measuring Channels

Because the instrument provides three identical measuring channels the user can make three independent measurements at the same time and he can display any two combinations on the CRT. Since the information is in logarithmic form, a ratio measurement can be simulated by subtracting two outputs. This gives the instrument extra versatility, especially when working with unlevelled sources, or

when a network is to be compared with a standard. Because the shaped signal is proportional to the power of the RF wave seen by the detector, the instrument is also able to measure absolute power levels on a swept basis.

Acknowledgments

The authors wish to acknowledge the project leadership of Dave Gildea. Bob Jacobsen receives plaudits from everyone on the project for his elegant solutions to the sticky problems of product design, and for creating an esthetic entity in the 8755A and its accessories. Our thanks, too, to Phil Spohn, always a guiding light in dark moments. Our gratitude to Bob Jeremiasen and his associates at the HP Loveland (Colorado) Division for their extraordinary efforts in the development and manufacture of the hybrid logarithmic amplifier. 

SPECIFICATIONS		FREQUENCY RESPONSE (ratio measurements):			HARMONIC GENERATION (with +10 dBm input power):												
Model 8755L Frequency Response Test Set		<table border="1"> <tr> <td><0.25 dB</td> <td><0.5 dB</td> <td><1.25 dB</td> </tr> <tr> <td>0.1</td> <td>8</td> <td>12</td> </tr> <tr> <td colspan="3">18 GHz</td> </tr> </table>			<0.25 dB	<0.5 dB	<1.25 dB	0.1	8	12	18 GHz			Above 1 GHz, typically 40 dB down; below 1 GHz, typically 30 dB down.			
<0.25 dB	<0.5 dB	<1.25 dB															
0.1	8	12															
18 GHz																	
(Includes 8755A Swept Amplitude Analyzer, 182A Oscilloscope Mainframe, 11664A Detectors (3) and 11865A Modulator. Systems also available with 180D (rack mount) and 181A or 181AR Oscilloscope Mainframes.)		ACCURACY (ratio measurements): <1.2 dB error up to 55 dB from reference, <2 dB to 60 dB from reference.			RECORDER OUTPUTS: 0.5 V/div with 100Ω output impedance.												
FREQUENCY RANGE: 100 MHz to 18 GHz.		DRIFT: Typically less than 0.2 dB for -50 dB ratio measurement during 12-hour period.			MARKERS AND BLANKING: Accepts inputs from HP 8620 and 8690 series Sweep Oscillators.												
MEASUREMENT RANGE		DETECTOR IMPEDANCE: 50 ohms nominal.			CONNECTORS: Type N standard. APC-7 and SMA available.												
Single channel: +10 dBm to -50 dBm		DETECTOR RETURN LOSS: <table border="1"> <tr> <td><20 dB</td> <td><17 dB</td> <td><10 dB</td> <td><8 dB</td> </tr> <tr> <td>0.1</td> <td>4</td> <td>8</td> <td>16</td> </tr> <tr> <td colspan="4">18 GHz</td> </tr> </table>			<20 dB	<17 dB	<10 dB	<8 dB	0.1	4	8	16	18 GHz				POWER: 48-440 Hz, 115/230 V ±10%, typically 85 watts.
<20 dB	<17 dB	<10 dB	<8 dB														
0.1	4	8	16														
18 GHz																	
[Damage level is +20 dBm (100 mW)]		MODULATOR INSERTION LOSS: <table border="1"> <tr> <td><3.8 dB</td> <td><4.3 dB</td> <td><5 dB</td> </tr> <tr> <td>0.1</td> <td>4</td> <td>8</td> </tr> <tr> <td colspan="3">12.4</td> </tr> <tr> <td colspan="3">18 GHz</td> </tr> </table>			<3.8 dB	<4.3 dB	<5 dB	0.1	4	8	12.4			18 GHz			WEIGHT: 34 lbs (15 kg).
<3.8 dB	<4.3 dB	<5 dB															
0.1	4	8															
12.4																	
18 GHz																	
Ratio of two channels: 60 dB.		On: <table border="1"> <tr> <td><3.8 dB</td> <td><4.3 dB</td> <td><5 dB</td> </tr> <tr> <td>0.1</td> <td>4</td> <td>8</td> </tr> <tr> <td colspan="3">12.4</td> </tr> <tr> <td colspan="3">18 GHz</td> </tr> </table>			<3.8 dB	<4.3 dB	<5 dB	0.1	4	8	12.4			18 GHz			DIMENSIONS (182A Mainframe): 8 in W x 13 1/2 in H x 19 1/2 in D (20 x 34 x 50 cm).
<3.8 dB	<4.3 dB	<5 dB															
0.1	4	8															
12.4																	
18 GHz																	
DISPLAY SCALE FACTOR: 10, 5, 1, or 0.25 dB/div., independent for each channel.		Off: <table border="1"> <tr> <td>≥35 dB</td> <td>≥40 dB</td> <td>≥45 dB</td> </tr> <tr> <td>0.1</td> <td>4</td> <td>8</td> </tr> <tr> <td colspan="3">12.4</td> </tr> <tr> <td colspan="3">18 GHz</td> </tr> </table>			≥35 dB	≥40 dB	≥45 dB	0.1	4	8	12.4			18 GHz			PRICE in U.S.A.: Model 8755L, \$3200.
≥35 dB	≥40 dB	≥45 dB															
0.1	4	8															
12.4																	
18 GHz																	
OFFSET: ±59 dB in 1- and 10-dB steps, independent for each channel.		MANUFACTURING DIVISION: MICROWAVE DIVISION 1501 Page Mill Road Palo Alto, California 94304															



Frank K. David (CENTER)

Frank David has been with HP since 1969. After receiving his B.S.E.E. degree in 1965 from the University of California at Berkeley, Frank designed power systems for two years, then returned to school at Oregon State University. He'll get his M.S. degree as soon as this thesis is completed. Frank's a member of IEEE. He's also a tennis player and a woodcarver (for fun, not profit).

Wayne L. Frederick (LEFT)

Wayne Frederick received his A.A. degree from San Jose City College in 1958, then worked in microwave device development before joining HP in 1965. Since 1968 he's been with the Microwave Division, doing applications engineering, systems maintenance and training, and development engineering. Wayne has been a member of the Naval Air Reserve since 1955. He's an assistant scoutmaster in the Boy Scouts of America, and his hobbies are photography and amateur radio.

Hugo Vifian (RIGHT)

Hugo Vifian was born in Berne, Switzerland. After high school, he completed a four-year professional apprenticeship with a telecommunication equipment manufacturer, then spent four more years there working in production, test, and design. A scholarship made it possible for him to receive his Diplom Ingenieur from the Swiss Federal Institute of Technology in 1967. After a brief period as an instructor, he joined HP in 1969, and since then has been involved in various network analyzer projects, the latest being the 8755A. Hugo looks forward to the day when his twin boys will be old enough to share his interest in flying and sailplaning, but for now he and his family confine their sailing to the water variety.

Versatile Display Unit Extends Correlator Capability

Together this new Spectrum Display and an HP Correlator form a versatile and economical instrument for analyzing signals and systems in the time and frequency domains simultaneously.

By David J. Morrison, Brian W. Finnie, Rajni S. Patel, and Kenneth H. Edwards

IN ENGINEERING AND RESEARCH, it often happens that measurements are most conveniently and accurately made in the time domain while subsequent information processing and design work may employ frequency-domain techniques. For example, autocorrelation functions, crosscorrelation functions, and impulse responses are useful time-domain measurements that are conveniently made by a digital correlator.¹ However, much engineering and scientific work uses frequency-domain techniques based upon the Fourier transforms of these functions—power spectra, cross power spectra, and transfer functions.

The new HP 3720A Spectrum Display is designed to provide frequency-domain displays of data measured using the HP 3721A Correlator as a time-domain signal analyzer. The Spectrum Display performs the discrete Fourier transform of the Correlator display and presents the result on its own storage cathode-ray tube. Axes can be Cartesian or polar, linear or logarithmic. The user can observe power spectra, Bode diagrams, Nyquist diagrams, and many other displays, changing from one to another simply by changing the settings of front-panel switches.

Together the Spectrum Display and the Correlator (Fig. 1) constitute a versatile, portable, low-cost analysis system for signals in the range dc to 250 kHz.

What the Spectrum Display Does

Inputs to the 3720A Spectrum Display are data records from the 3721A Correlator. Each data record consists of 100 sample values of a correlation function computed by the Correlator—autocorrelation for a single Correlator input signal, cross-

correlation for two. The Spectrum Display Fourier-transforms the data from the Correlator, producing 100 real and 100 imaginary coefficients. There are two basic cases.

Case 1. An autocorrelation function is transformed



Fig. 1. New Model 3720A Spectrum Display (top) complements 3721A Correlator (bottom). Spectrum Display accepts correlation functions computed by Correlator and transforms them into the frequency domain, computing real and imaginary coefficients at 100 different frequencies.

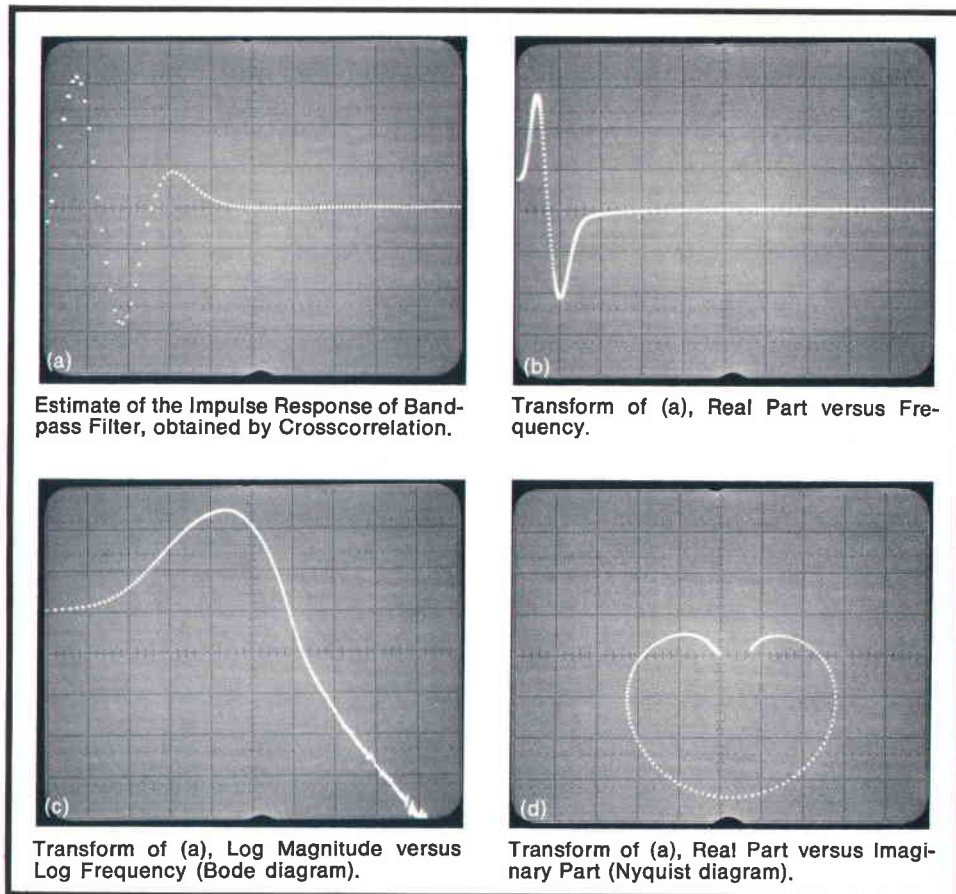

Fig. 2. Correlator display (a) and corresponding Spectrum Display displays. User selects displays by means of front-panel switches.

into the power spectrum of the Correlator input signal. This spectrum consists of 100 real coefficients. All imaginary coefficients are zero because the autocorrelation function is symmetrical about the time origin. Only one data record is required in this case, because the negative-time half of the autocorrelation function can be assumed to be the mirror image of the positive-time half.

Case 2. A crosscorrelation function between two input signals is transformed into the cross power spectrum. This spectrum is complex, consisting of 100 real coefficients and 100 imaginary coefficients, a total of 200 independent coefficients. Because any transformation of 100 independent estimates of a time function can produce at most 100 independent frequency coefficients, two independent data records are required by the Spectrum Display. Usually, two separate crosscorrelation measurements are made and the resulting data records are loaded, one at a time, into separate input stores in the Spectrum Display.

By setting front-panel switches on the Spectrum Display, the user determines whether a data record from the Correlator will go into input store 1 or input store 2, whether the transform will be real

or complex, and whether it will be performed on the contents of store 1 or store 2 or both together.

For the two data records required for computation of a complex cross power spectrum, two independent crosscorrelation functions can readily be obtained by measuring one with input signal A delayed with respect to input signal B, and the other with B delayed with respect to A. A switch setting on the Correlator is the only change required.

Displays

The Spectrum Display can display the contents of either of its data stores, or the transform of either or both of them. The ability to display the contents of a store is useful when a second data record is being measured using the Correlator; both records can be observed at the same time.

Transforms are displayed on the Spectrum Display's built-in CRT as they are generated. Logarithmic and polar converters in the Spectrum Display give the user a variety of possible displays. Thus the real or imaginary parts of a transform, or the magnitude or phase can be displayed as functions of frequency or log frequency, and several other combinations are also possible. Fig. 2 shows

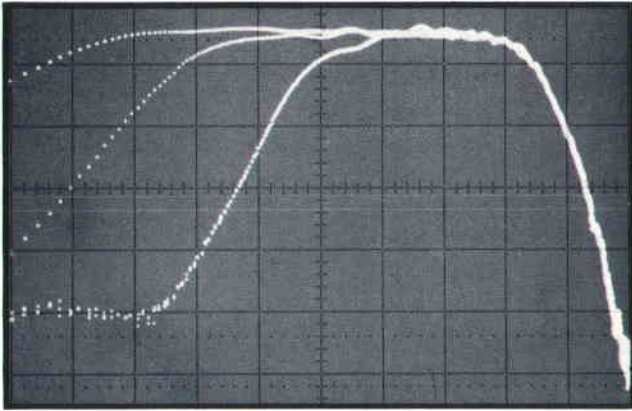

Fig. 3. Storage tube allows several displays to be viewed simultaneously. Here the frequency response of an adjustable bandpass filter is shown for three values of the lower cutoff frequency.

some examples.

Using the storage facility, several displays may be superimposed, as shown in Fig. 3. This is useful for comparing the results of adjustments or changes in the parameters of an experiment.

The scale factors of the displayed function are automatically computed and shown by a front-panel light-emitting-diode indicator. For examining low-amplitude parts of a transform, there is a GAIN control which increases the internal gain of the computing circuits. The scale-factor indicator automatically changes to take account of the GAIN switch position.

Inside the Spectrum Display

The equations describing the discrete Fourier transform of K samples, $x(k\Delta t)$, of a time waveform are implemented directly in the Spectrum Display. The real coefficients are given by

$$R(n\Delta f) = \frac{1}{K} \sum_{k=0}^{K-1} x(k\Delta t) \cos 2\pi n\Delta f k\Delta t,$$

and the imaginary coefficients are given by

$$I(n\Delta f) = \frac{1}{K} \sum_{k=0}^{K-1} x(k\Delta t) \sin 2\pi n\Delta f k\Delta t,$$

where $n = 1, 2, \dots$ and $\Delta f = 1/K\Delta t$.

Fig. 4 shows the functional blocks necessary for direct implementation of a discrete Fourier transform. First a set of samples of a correlogram is required. A digital data record is transferred from the HP 3721A Correlator via an interconnecting cable to one of the two stores in the HP 3720A Spectrum Display.

The stored information may be updated automatically so the displayed transform may track a slowly changing correlogram. Alternatively the stored information may be held, enabling the Correlator to perform fresh experiments while transforms of the held data are manipulated and examined. The two stores, each holding a data record consisting of 100 12-bit words, may be transformed separately, or their contents may be treated as one double length record.

The expressions for the discrete transform call for cosine and sine waves of controlled frequency. These are produced by a programmable generator. Each Fourier coefficient is calculated by summation of the results of hybrid multiplication of the digital record, term by term, by successive analog samples of the cosine or sine wave.

The lowest frequency of the generated waveform, 375 Hz, is used in calculating the transform coefficients at the frequency Δf . The highest frequency, 37.5 kHz, is used in calculation of the Fourier coefficients at $100\Delta f$. The sampling rate of 75 kHz is fixed

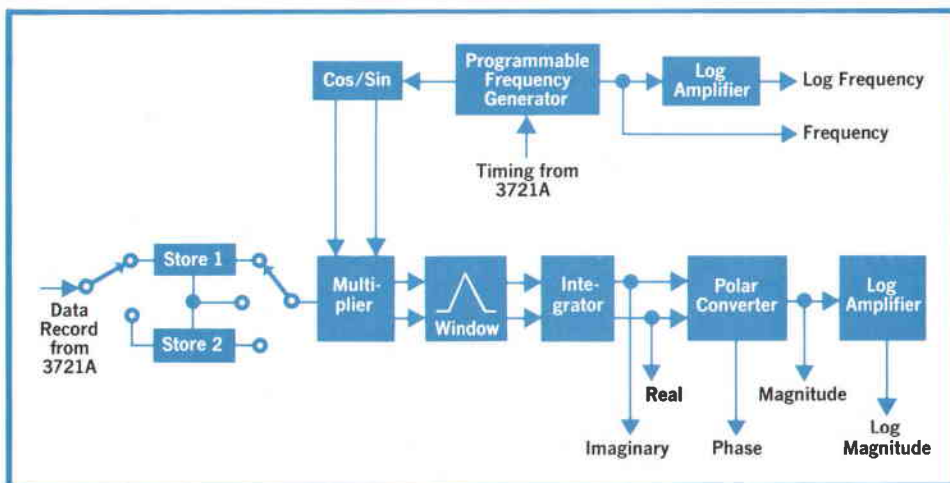

Fig. 4. Discrete Fourier transform is implemented directly in the 3720A Spectrum Display. Data records in the two input stores can be transformed separately or treated as one double-length record. Triangular window is switch-selectable.

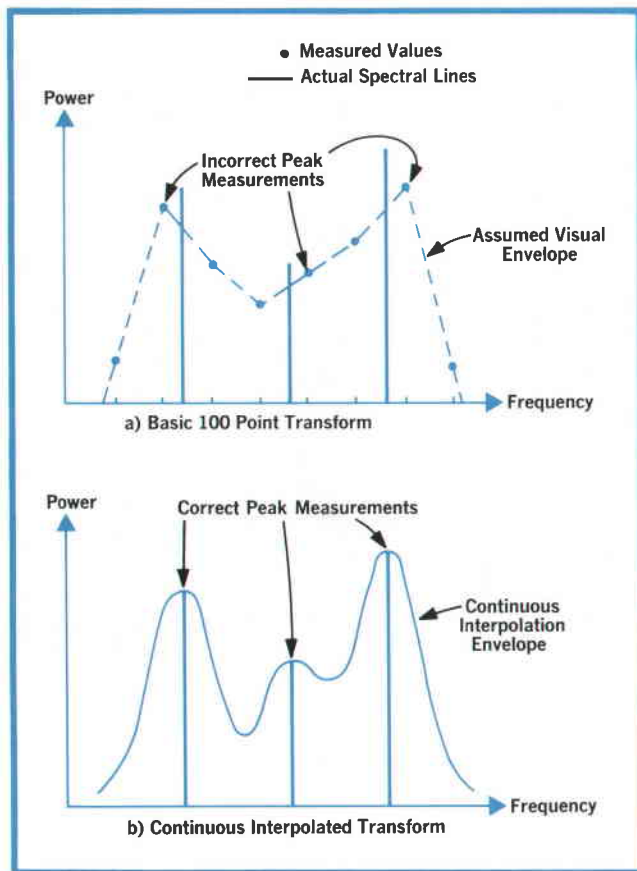

Fig. 5. Continuous interpolation between points reveals the true values of spectral peaks. Interpolation is switch-selectable.

for all frequencies of calculation.

In normal operation, calculation of the Fourier coefficients is performed at each of 100 frequencies using first the sinusoidal and then the cosinusoidal multiplying signal. The results are accumulated in an adjustable-gain analog integrator and stored on two capacitors, one for the imaginary coefficient and the other for the real coefficient.

All samples in a data record contribute to every Fourier coefficient, and a total of 100 pairs of coefficients are produced. The oscillator is swept over two frequency decades during calculation and display of a complete set of Fourier coefficients, each cycle lasting 850 milliseconds.

The frequencies $n\Delta f$ of the transform coefficients are determined by the Correlator time scale control settings, which are digitized and transferred to the Spectrum Display via the interconnecting cable. The frequencies $n\Delta f$ are not related to the harmonics of 375 Hz used in calculating the coefficients.

Resolution and Interpolation

The Spectrum Display can be regarded as a set of

100 narrow-band filters centered on harmonically related frequencies, all operating on the same input signal. The output of each filter is a measure of the energy in the input signal in a band of frequencies centered on the frequency of calculation.

The resolution of the transform is usually defined as half the bandwidth of the principal lobe of each of the 100 filters. In the 3720A the effective filters are of constant bandwidth and the resolution in hertz is $\Delta f = 1/200\Delta t$.

If the lowest frequency of calculation is exactly $1/200\Delta t$, the coefficients calculated are those of the Fourier series. However, the lowest frequency is not restricted to this value. The front-panel INTERPOLATION control can be used to vary this frequency over a continuous range between $1/200\Delta t$ and $1/100\Delta t$. Changing this frequency is equivalent to moving the set of effective filters by an increment in the frequency domain. Each new set of coefficients calculated will be mutually independent, but will not be independent of the Fourier-series coefficients or any other interpolated set.

The INTERPOLATION control gives continuous adjustment of the frequencies of calculation throughout the frequency spacing of the Fourier series. In the automatic position of the control, ten interpolated sets of coefficients are calculated, the entire sweep producing a near continuous display on the screen. All of the displays shown in Figs. 2, 3, and 6 were produced using this feature.

The accuracy of estimation of the energy of line or narrow-band spectra is much improved by the use of interpolation (see Fig. 5).

Marker Aids Harmonic Identification

Identification of the frequency of a particular displayed point is straightforward if frequency is plotted linearly on the horizontal axis. The lowest frequency and frequency spacing are available from the scale-factor display, and the harmonic number can be obtained using the CRT graticule. With the INTERPOLATION control switched to the manual setting the frequency spacing is 10 points per graticule division. The lowest frequency is located at the left hand vertical grid line of the graticule, and 100 points occupy the full screen width.

An arrowhead marker can be set to indicate any point on the trace. The marker is useful for identifying corresponding points on different displays—e.g., the 90° phase shift point on a Nyquist diagram and the corresponding Bode diagram (Fig. 6).

When the horizontal axis doesn't represent frequency, the marker can help identify the frequency of a point. Placing the marker on the point of in-

terest and switching the HORIZONTAL control to FREQUENCY makes it possible to determine the desired frequency.

Windows

The information contained in the correlation function supplied to the Spectrum Display is a function of the range of delay time used in its calculation. This selection of a finite length data record from a theoretically infinitely long correlation function is inevitable in any practical Fourier transform measurement and is known as windowing.

The effect of windowing is most easily explained by once again treating the combination of Correlator and Spectrum Display as a set of narrowband filters. If the correlation information is taken directly from the Correlator and directly transformed, the effect is to give each of the filters a $\sin x/x$ shaped response. This response arises because of the finite length of the correlation function and because of the abruptness of the truncation at the limits of the delay.

Nothing can be done about the effects of the length of the correlation function, but the truncation effects can be ameliorated by preprocessing the correlation function to a gentler cutoff. Many window functions are used for this purpose.⁴ One of the most convenient uniformly decreases the correlation function by weighting it progressively with a triangular window function. The Bartlett window, as this function is known, is available as a standard feature of the Spectrum Display.

Dynamic Range

The dynamic range of an instrument can be defined as the ratio of the maximum signal handling capability to the noise level. For the Spectrum Dis-

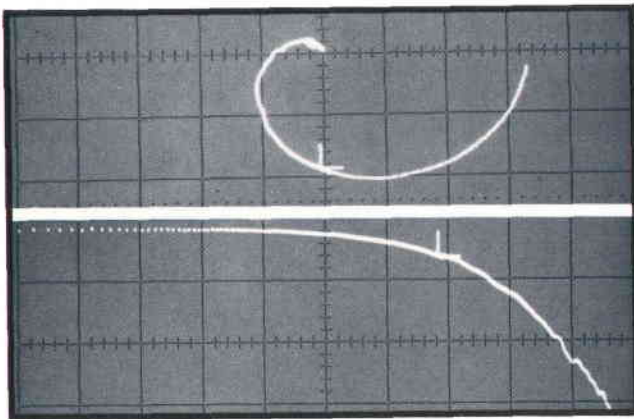

Fig. 6. Arrow marker is useful for identifying points when switching from one display to another, and as an aid in identifying the frequency of a selected point.

play, this is most usefully expressed in terms of the spectral analysis performance of the Correlator/Spectrum Display combination, since the latter instrument doesn't have a conventional input signal.

The digital factors influencing dynamic range are quantization of the input signals to the Correlator, truncation or quantization introduced by the transfer of data from Correlator to Spectrum Display, and quantization noise of the digital inputs to the hybrid and window multipliers in the Spectrum Display. The principal analog factors are harmonic content of the sinusoidal generator within the Spectrum Display and offsets introduced by analog multiplications and summation.

For a broadband spectrum the dynamic range of the quantizers is at least 3.7 decades, and will in most instances be better than this (see appendix). The digital processor in the Correlator uses 24-bit arithmetic and can be considered to be error-free for this dynamic-range discussion. Transfer of data from the Correlator to the Spectrum Display involves truncation to 12 bits, which has been shown by computer simulation to support a dynamic range of over 4 decades. Thus, the principal limitations on the dynamic range of the spectrum analyzer come from the analog circuit elements.

The hybrid multiplier and the window multiplier have at least three decades of range, both being determined by the tracking accuracy of a resistor ladder and the drift of an operational amplifier.

The sinusoidal signal used in the transform is produced by diode shaping of a triangle wave generator. The total distortion of the sinusoid is better than 2.3 decades below fundamental. The effect of the distortion is distributed over a number of unwanted harmonics and the error introduced at any calculated point is a function of the harmonic content of the signal under analysis.

Offsets, either of the generated sinusoid or arising in subsequent analog processing, contribute directly to dynamic range. Because of the variable gain in the transform processor, conventional chopper amplifier techniques cannot be used to minimize the resulting errors. The capabilities of the programmable sine/cosine generator have been used to reduce offsets to a very small level. Each coefficient is calculated twice; first with a multiplying function of reference phase, and then with its inverse. The two results are subtracted to cancel the offset term. Offsets of real and imaginary coefficients can be maintained at better than 3.6 decades below fundamental throughout the operating range.

By attaching a DVM to the X-Y plotter output and using the record cycle control, the full dynamic

range is available to the user. Overall, the dynamic range exceeds 400:1.

Programmable Sinusoidal Generator

The sinusoidal generator must sweep over two decades and be rapidly switched from sine to cosine generation, with either reference or inverted phase. Its harmonic purity and stability dictate the overall performance of the instrument.

The circuit used is a variable-frequency triangle generator⁵ with subsequent diode shaping. It is sketched in Fig. 7. The repetition rate of the triangle wave is controlled by the programmable input resistor of the integrator, R_p . It is capable of spanning a two-decade frequency range (375 Hz to 37.5 kHz). The reference supply is switched by a comparator which detects both positive and negative excursions of the integrator beyond preset values. The generator can be started in any one of four quadrature phases by the use of FET control switches.

The operation of the circuit may be summarized as follows. Suppose, first, that the integrator output has been preset to zero. Then, using switch S1, either the positive or negative preset voltage can be set at the comparator, to generate triangle waves of the appropriate phase. Consider, for example, that the negative voltage is used. The comparator latches in the preset state due to positive feedback, and, when the integrator is released, the output increases linearly until the voltage at the comparator (controlled by the dividing network of resistors R1 and R2) exceeds zero. The comparator then switches with both integrator input voltage and the comparator input voltage going positive.

The quadrature phases are obtained by presetting the integrator to one of its non-zero preset voltages (positive or negative) via S2.

The frequency is controlled by the programmable resistor to better than 0.5%.

Polar Converter

Operation of the polar converter is based on the equation

$$R \cos \omega t - I \sin \omega t = M \cos (\omega t + \phi)$$

where $M = \text{Magnitude} = \sqrt{R^2 + I^2}$, and $\phi = \text{phase} = \tan^{-1} I/R$.

The block diagram, Fig. 8, illustrates the implementation of the polar converter in the Spectrum Display. The real and imaginary parts of the transform are modulated, using FET switches, by 75-kHz reference and quadrature-phase square waves, respectively. An operational amplifier sums and filters the modulated signal and is followed by an

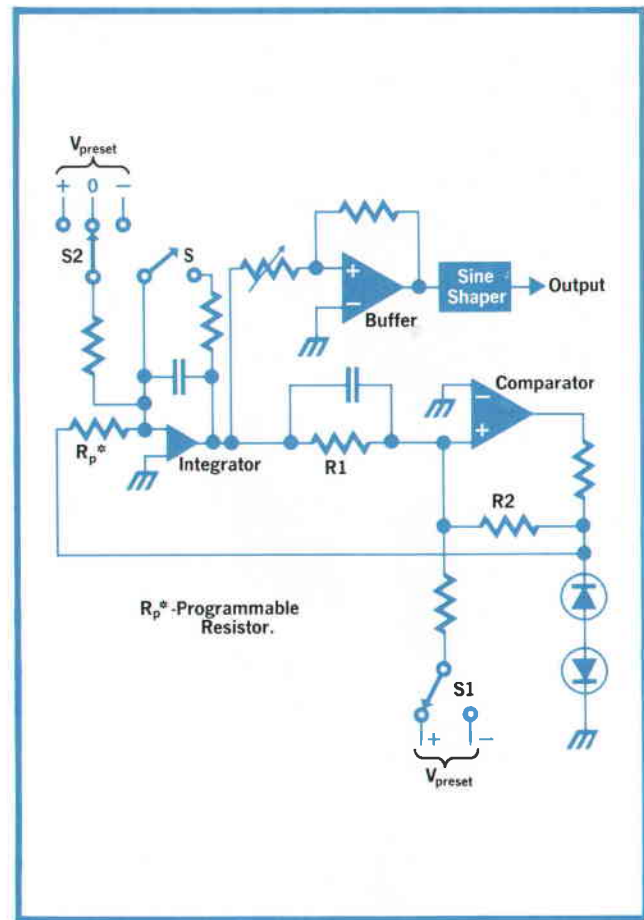

Fig. 7. Programmable generator produces the sine and cosine waveforms used in the transform calculations. It sweeps over two decades in frequency and has excellent stability and spectral purity.

adjustable phase compensation network, which controls errors due to filter misalignment.

Phase measurement is accomplished by integrating a fixed voltage over the period between the leading edge of the reference square wave and the zero-crossing time of the magnitude sinusoid.

Whenever the sinusoid leads the reference (positive phase angles), the polarity switch applies a fixed voltage to the integrator to give a positive-going ramp. Conversely, when the sinusoid lags, an equal-magnitude voltage of opposite polarity is applied. The zero crossing of the sinusoid is detected by a comparator followed by a monostable multivibrator. The latter triggers off one edge of the comparator output only, and has an output pulse of period one-half that of the modulating frequency. The use of this pulse rather than the comparator output in the phase detector circuitry eliminates errors due to differences between the rise and fall times of the zero-crossing detector.

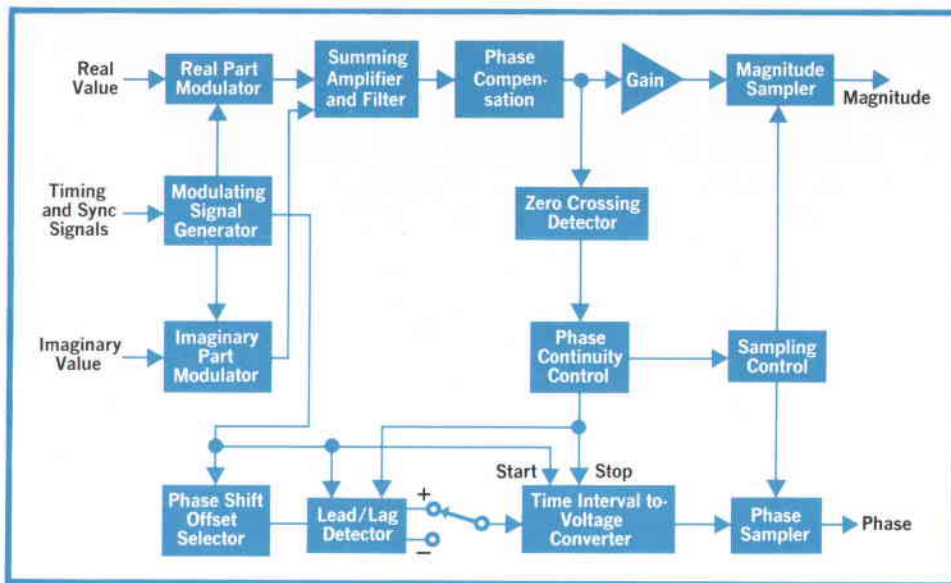

Fig. 8. Polar converter converts real and imaginary parts of transforms to magnitude and phase for display.

Magnitude is measured by sampling the peak of the magnitude sinusoid. The sampling pulse is derived from the phase detector circuit to assure that the sample is taken at the peak regardless of the phase relationship between the reference modulation signal and the resultant modulated sinusoid. To allow for settling time, both magnitude and phase values are sampled on the tenth modulation cycle after computation of fresh real and imaginary values, giving a total conversion time of 1.06 ms.

Acknowledgments

We are indebted to a large number of people at South Queensferry for their help and encouragement at all stages of the work. In particular, David Dack was deeply involved in theoretical studies and in preliminary development of the instrument. David Heath, our product designer, and Colin Deighton, our test engineer, have been invaluable throughout the project. Our colleagues in the marketing department, especially Fred Bennett and Peter Garforth, have both stimulated and challenged us continually from product definition to first shipment.

Above all, we wish to record our debt to Alister McParland. With his death six months ago, we lost a very good friend and the project lost a most able and experienced circuit designer.

Alister joined HP in 1966 to work on the design of the 3722A Noise Generator. He undertook a major part of the digital circuit design for the 3721A Correlator and, until his sudden death in December 1971, he worked on various aspects of the design of the 3720A Spectrum Display, contributing particularly to the control circuitry and the polar con-

verter. Before joining HP, Alister worked on digital on-line correlation at Edinburgh University.

APPENDIX

Effects of Input Quantization

The effect of quantization in an analog-to-digital converter is to add uncorrelated broadband noise to the desired signal. The noise power is $q^2/12$, where q is the amplitude of one quantization step (assuming all steps equal). If the same quantizer is shared between input channels of a correlator, or if similar quantizers are used, the additive noise signals correlate with one another and are a source of bias error in the estimation of the correlation function. The HP 3721A Correlator, therefore, employs dissimilar analog-to-digital converters on the input channels. A fine 7-bit quantizer is used for one input channel and a fast 3-bit quantizer for the second input channel.

Mathematically, each input is equivalent to a linear gain ($=1$, for normal input signal levels within the HP 3721A input range) plus additive noise. The additive noise is uncorrelated with the signal in each channel. If the input signals are uncorrelated, then there will be no correlation between the additive noise signals that will give rise to a bias error in the estimate of the crosscorrelation function and so in the estimate of the spectrum. The worst case of correlation occurs between identical input signals, so bias error will be greatest for autocorrelation and power spectral density estimates. The error is, at worst, wideband with a value $q^2/12$ (where q is the step size of the interfering quantizer) and is distributed equally over all frequencies at which the transform is calculated. If the measured spectrum is of wideband noise, then the interference will be 3.7 decades below full scale. For a single line spectrum, whose signal energy is concentrated at one frequency, the range between it and the interference will be 5.4 decades.

The variance errors on the estimates can be derived using standard techniques employing the statistical properties of the signals and of the noise terms.⁶

SPECIFICATIONS

HP Model 3720A Spectrum Display

INPUT

DATA AND RANGE: The 100 displayed points from the 3721A Correlator are transmitted as a series of 12-bit digital words, time-multiplexed with calibration information from the 3721A.

INPUT STORAGE: Two separate input stores, 1 and 2, allowing two independent blocks of 100 points to be stored.

PROCESSOR

COMPUTED TRANSFORMS:

- The Real transform of the contents of either store.
- The Complex transform of the contents of either store.
- The Complex transform of the contents of both stores 1 and 2 taken together.

FREQUENCY RANGE: 0.005 Hz to 250 kHz using internal 3721A clock. Lower limit extendable down to dc with external clock. In any one measurement two frequency decades are displayed, the highest frequency being $1/2\Delta t$ Hz; where Δt is the Correlator TIMESCALE setting.

DYNAMIC RANGE: Ratio of full scale signal to noise level, for any fixed gain, is better than 50 dB.

GAIN: Continuously variable over a 2 decade, 40 dB range in seven discrete steps, with intermediate vernier.

SPECTRUM FLATNESS: Amplitude flatness over entire instrument frequency range is within $\pm 1\%$.

WINDOW: Two choices are available.

OFF—data is directly transformed (nominal bandwidth = $1/200\Delta t$).

ON—data is weighted with a triangular window prior to transformation (nominal bandwidth = $1/100\Delta t$).

INTERPOLATION:

MANUAL—allows simultaneous and equal shifting of the frequency of all 100 displayed points by an amount up to 1 full frequency interval Δf .

AUTO—automatically performs a fine frequency shift by calculating ten equally spaced points across each frequency interval Δf .

FREQUENCY INTERVAL (Δf): Spacing between 2 adjacent frequency points in Manual Interpolation mode. $\Delta f = 1/200\Delta t$ Hz.

OUTPUTS

TRANSFORM PRESENTATION: The transform may be presented using the following combinations of axes; any Vertical axis may be used with any Horizontal axis.

VERTICAL	HORIZONTAL
Phase	Frequency
Log Magnitude	Log Frequency
Magnitude	Real
Imaginary	Phase
Real	

CRT DISPLAY: Variable persistence 8 x 10 division CRT display, with storage facility.

MARKER: A movable marker can be placed on any displayed point on the CRT trace. If axes are altered the marker is automatically transferred to the corresponding point on the new display.

CALIBRATION: Presented on an illuminated indicator panel. Displayed functions are automatically calibrated for horizontal and vertical axes and nominal frequency interval Δf .

X-Y RECORDER: Separate analog outputs corresponding to horizontal and vertical coordinates of the CRT display.

PRICE IN USA: \$5995.00

MANUFACTURING DIVISION: HEWLETT-PACKARD LIMITED
South Queensferry,
West Lothian, SCOTLAND



References

- Hewlett-Packard Journal, November 1969.
- Hewlett-Packard Journal, September 1967.
- R. B. Blackman and J. W. Tukey, "The Measurement of Power Spectra," Dover Publications.
- G. M. Jenkins and D. G. Watts, "Spectral Analysis and Its Applications," Chapter 6, Holden Day.
- R. C. Hanson, "Compact Function Generator Covers 0.0005 Hz to 5 MHz," Hewlett-Packard Journal, June 1969
- J. W. Bendat and A. G. Piersol, "Measurement and Analysis of Random Data," John Wiley & Sons.



(LEFT to RIGHT)

David J. Morrison

David Morrison joined HP in 1967 and helped develop the 3721A Correlator. He's now project leader for the 3720A Spectrum Display. He received his B.Sc. degree in 1967 from Glasgow University and his M.Sc. degree in 1972 from Heriot-Watt University in Edinburgh. He is an Associate Member of the IEE.

Brian W. Finnie

After joining HP in 1965, Brian Finnie worked on the design of the 3722A Noise Generator and in 1967 initiated the 3721A Correlator project. He led the group that produced the 3720A Spectrum Display. Brian graduated from Manchester University in 1962 with a B.Sc. degree and received his Ph.D. degree in 1966 from Edinburgh University.

Rajni S. Patel

Rajni Patel came to HP in 1967. After helping develop the 3721A Correlator, he moved on to production engineering, and then returned to the lab to work on logic and hybrid circuits in the 3720A Spectrum Display. He's a 1967 B.Sc. graduate of the University College of North Wales.

Kenneth H. Edwards

Ken Edwards was a member of the 3720A development team. He joined HP in 1970. Before that, he lectured in control systems at Queen's University, Belfast, and then at University College of North Wales. He received his B.Sc. degree in 1961 and his Ph.D. degree in 1965 from Queen's University. He's a member of the IEE.

Voltage Precision and High Current Capability— Both in One Power Supply

This new family of power supplies combine the accuracy of a calibrator with brute force power

By George G. Emmermann

SUBSTANTIAL CURRENT IS NEEDED AT PRECISELY KNOWN VOLTAGES in a number of applications. Among these are calibration and performance evaluation of positioning servos, memory excitation, and A-to-D converter tests. Also included are TTL threshold and other semiconductor tests where it may be expedient to test several devices in parallel.

High current and voltage precision are conflicting requirements, however. Temperature rise within a supply caused by higher power tends to degrade stability. Freedom from load effects at high current levels demands that the effective output impedance approach zero more closely. In addition, transformer leakage flux levels are higher, increasing the difficulty of obtaining low ripple levels.

The usual solution to these problems has been to use a precision voltage source to control a power supply that has the desired current capability. Now there is a simpler and more economical solution. A new family of power supplies has both voltage precision—i.e. 0.025% accuracy, 0.0005% regulation—and output power capability (up to 40 volt-amperes).

Two of the new units (Models 6104A and 6114A) can supply 2 amperes up to 20 volts and 1 ampere on up to 40 volts. The other pair (Models 6105A and 6115A) supply 800 mA up to 50 volts and 400 mA up to 100 volts. These are dual-range supplies with automatic crossover between ranges.

One model of each pair has a 4-digit pushbutton switch with a 5th digit continuous vernier (Fig. 1) that enables the output voltage to be set quickly with a resolution of 0.2 mV, a resolution made useful by the unit's high accuracy and stability. These units (Models 6114A and 6115A) are useful for

calibrating devices on the production line and for a number of uses on the lab bench. They have one meter that can be switched to read either current or voltage.

The other units (Models 6104A and 6105A) are intended primarily for applications where the output voltage is programmed by an external precision device. They have 10-turn controls for setting the voltage at the front-panel in the absence of an external controller. Two meters are provided, one for monitoring voltage and the other for current.

All of these supplies can also work in a constant current mode with the current regulated within 0.01%. A front-panel control establishes the current level. This control can also be used to establish a current limit when the supply is operating in the constant-voltage mode. An indicator lights up to show when control of the output passes from the voltage regulator to the current regulator.

Power Plus Stability

The stability needed for high precision in a power supply has usually been obtained by enclosing the voltage-reference diode and other critical elements in an oven. The oven holds these components at a constant temperature, isolating them from changes in the ambient.

But, by solving one problem, ovens create others. For one, the oven may take a half hour or so to warm up and stabilize the output level. For another, the switching of the oven's regulator may affect the output. Then too, the elevated temperature inside the oven may accelerate degradation of the components within. And, an oven adds cost and complexity.

A better cost/stability ratio was achieved in the



Fig. 1. Model 6115A Precision Power Supply has 4-digit push-button switch for quick setting of voltage. Vernier enables output voltage to be selected with 0.2 mV resolution. Output range is 0–50 V at 0.8 ampere, and up to 100 V at 0.4 A. Model 6114A is identical except for output voltage and current ratings (0–20 V at 2 A, up to 40 V at 1 A).

new supplies by using higher quality components without an oven. The reference-voltage diode is temperature compensated. The comparison amplifier is a newly available, low-drift, monolithic IC manufactured to HP's specifications. It has the high gain needed for good load regulation at high output current levels, but it dissipates little power. Preci-

sion wire-wound resistors are used in networks that control the output voltage, and the reference voltage is trimmed with a deposited-metal trimmer that has a temperature coefficient of 20 ppm/°C and excellent long-term stability.

As a result, the pushbutton supplies have an overall temperature coefficient of 0.001% + 15 μ V per degree C, and the temperature coefficient of the supplies that use the 10-turn controls is 0.005% + 25 μ V per degree C (Fig. 3). All warm up to specified accuracy within 5 minutes (Fig. 4) an especially important consideration if a supply is to be used



Fig. 2. Model 6105A Precision Power Supply (and similar Model 6104A) has 10-turn control and extra meter for setting voltage. Otherwise Models 6104A and 6105A function same as Models 6114A and 6115A.

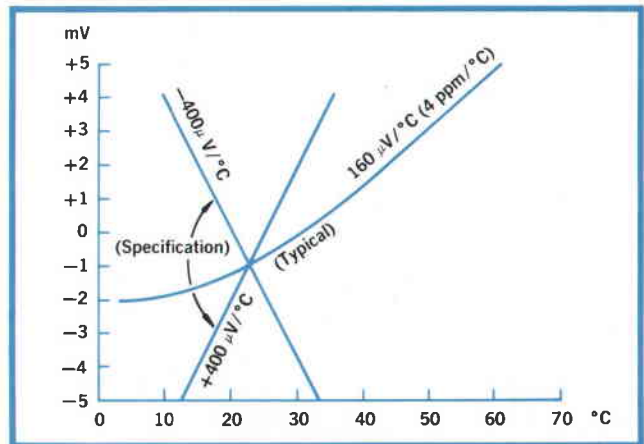

Fig. 3. Effect of temperature on typical supply in new family.

Table I

Model	6116A High-stability Power Supply	New 6115A Precision Power Supply		741A AC-DC Δ V/M/DC Standard
Output V	0-100 V	0-50 V	50-100 V	0-1000 V
Output I	0-200 mA	0-0.8 A	0-0.4 A	0-20 mA
Accuracy	0.1% + 1 mV	0.025% + 1 mV		0.015% + 15 ppm of range
Stability (8 hours)	0.1% + 100 μ V	0.0015% + 15 μ V		0.001% + 1 ppm of range (24 hrs)
Temperature Coefficient	(10 ppm + 10 μ V)/ $^{\circ}$ C	(10 ppm + 15 μ V)/ $^{\circ}$ C		(3 ppm + 1 ppm of range)/ $^{\circ}$ C
Price	\$375	\$540		\$2145

as a portable calibrator. Typical overall long-term stability is shown by the recording in Fig. 5.

Table I compares the performance of one of the new family with those of a high-quality lab supply and a voltage standard. Note that the current output capability of the new supply is substantially greater than either of the others. The stability and

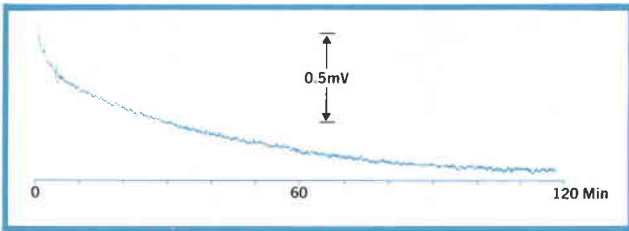

Fig. 4. Warm-up characteristic of new power supplies. This recording shows output of Model 6115A, set arbitrarily to 15.893 volts. Within an instant of switch-on, output is within rated accuracy for that voltage (± 4 mV ± 1 mV).

accuracy of the new supply approaches those of the voltage standard whereas its price is more like that of the lab power supply.

Dual-Range Efficiency

Temperature rise within the new supplies is lower than the usual series-pass regulator supply because of the higher efficiency of the dual-range configuration. In any supply that has a fixed rectifier output, the series regulator dissipates considerable power when the unit supplies high current at a low voltage. This is because the regulator in-

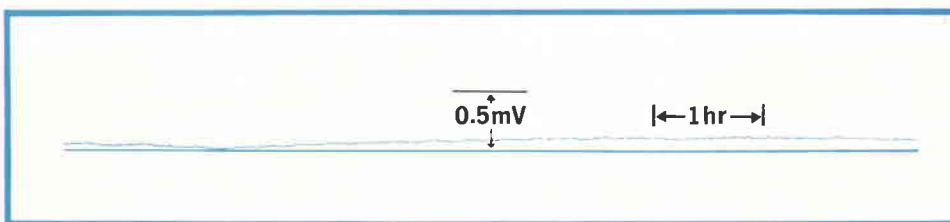

Fig. 5. Stability of new power supplies shown by 8-hour recording of Model 6115A output monitored by differential voltmeter rated with less than 1 ppm/hour drift. Power supply output, arbitrarily set to 15.893 volts, changes less than 0.125 mV.

troduces the voltage drop required to bring the output down to the level selected.

The power supplies described here reduce regulator dissipation at low output voltages by using two "raw" dc supplies and two regulators, as described in Fig. 6. One supplies maximum output current up to one-half the maximum output voltage, and the other supplies the higher voltages, but only up to one-half the maximum current. Internal power dissipation over the full range therefore has the characteristic shown in Fig. 7 and is much lower than it would be with a single regulator.

Ripple Reduction

Perhaps the most difficult problem to resolve economically was reduction of transformer induced ripple to less than the design goal of 100 μ V peak-to-peak at 60 Hz. Stray magnetic fields from the power transformer can induce voltages in three circuits that affect the output voltage: (1) the constant-voltage comparator input; (2) the reference voltage output; and (3) the voltage-control resistor. Connections to all these circuits are brought to a rear-panel barrier strip so that the power supply can be programmed by an external resistance or voltage, so the "sense" leads can be brought to an external point to regulate the voltage at that point, and so that supplies may be operated in series for higher voltage or in parallel for higher current under one-knob control. Ripple problems arise when stray magnetic fields induce currents in the leads that connect the circuits to the barrier strip.

To reduce the induced voltages, the leads were routed as far as possible from the transformer, and the transformer was oriented to minimize the fields near the leads. The two leads for each circuit loop were made the same length and run closely adjacent to each other on the printed-circuit boards and as twisted pairs off the boards. Parasitic impedances associated with the input to the voltage comparator amplifier were carefully balanced for maximum rejection of common-mode signals. Any current that may be induced in the reference-circuit loop is bypassed around the programming resistor by a capacitor. As a result, ripple is less than 100 μ V peak-to-peak, an order of magnitude better than the

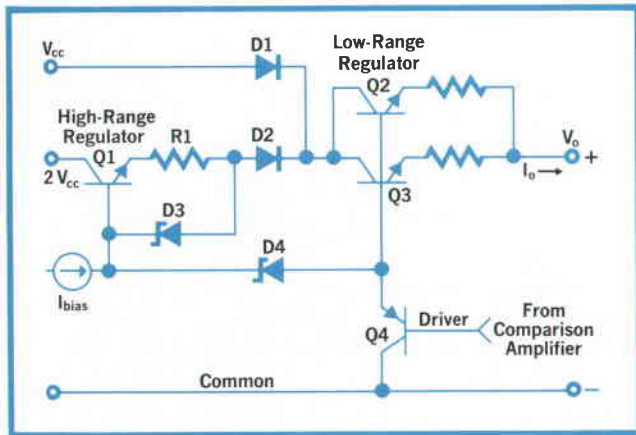

Fig. 6. Dual-range regulator uses power transformer with two output windings and associated rectifier circuits (not shown) to supply two dc voltages, V_{cc} and $2V_{cc}$. At low output voltages ($V_o \ll V_{cc}$), voltage at collectors of Q2 and Q3 back-biases diode D2 and all output current comes from V_{cc} . D2 begins to conduct when output is increased to within 4 volts below V_{cc} . At higher output voltages, collectors of Q2 and Q3 go above V_{cc} , back-biasing D1. Collector-emitter voltages of transistors Q2 and Q3 are then clamped at a low level and all regulation is accomplished by transistor Q1 with current supplied by $2V_{cc}$ supply. Resistor R1 and zener diode D3 limit maximum current to one-half that of low-range maximum.

usual series-pass regulator supply of comparable output capability and, of course, many times better than supplies that use switching regulators.

Overvoltage Protection

To protect sensitive circuits from excess voltages caused by accidental misadjustment of controls, particularly when the supply is working in the constant-current mode, these new units have a sensitive "crowbar" circuit (Fig. 8) that short-circuits the output within 10 μ s of occurrence of the overvolt-

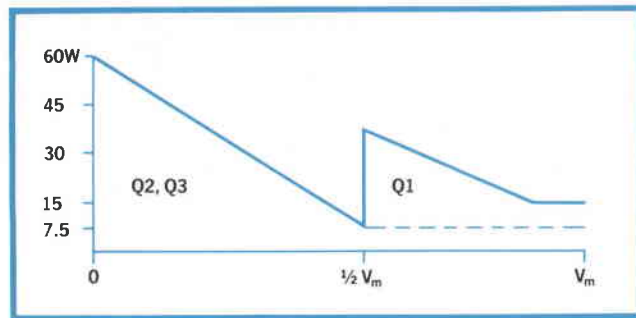

Fig. 7. Series regulator power dissipation at maximum rated output current. Use of low-voltage regulator (Q2, Q3) substantially reduces dissipation below that which would have occurred if high-voltage regulator (Q1) worked over full range. At the same time, maximum current in low-voltage range is doubled.

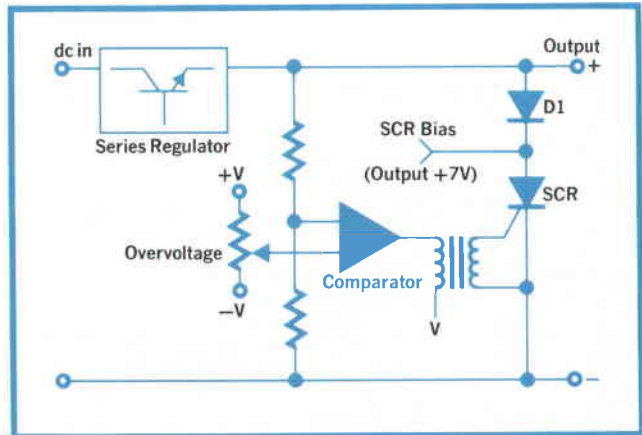

Fig. 8. Crowbar SCR fires whenever comparator senses that output voltage has risen a half volt or so above level determined by front-panel "overvoltage" control. Normally SCR is decoupled from output by diode D1 so SCR can be biased about 7 volts above output level, assuring that SCR fires even when trip level is set as low as 0.5 volts.

age. A front-panel screwdriver control sets the trip level at any voltage from 10% above the supply's maximum output down to as low as 0.5 volts. It can also be triggered by an external signal where an orderly shut-down of several supplies in a system may be required. A front-panel indicator lights up to show that the crowbar has fired.

Space was provided within the instrument for installation of optional optoelectronic isolators for coupling out the status of the overvoltage and current mode indicators. These can be useful when the supply is used as part of an automatic test system.

Acknowledgments

Jack Leber and Don Pauser did an outstanding job in the mechanical design and circuit board layout. The author also wishes to acknowledge the contributions of Wayne Jacobus, David Ziegler, and Larry Neill who built and evaluated prototype units.



SPECIFICATIONS

HP Models 6104A, 6105A, 6114A, 6115A Power Supplies

DC OUTPUT

	6104A, 6114A		6105A, 6115A	
VOLTS:	0-20	20-40	0-50	50-100
AMPERES:	0-2	0-1	0-0.8	0-0.4

OUTPUT IMPEDANCE (typical): 0.05 mΩ in series with 3 μH.

LOAD REGULATION

	6104A and 6114A	6105A and 6115A
Voltage (with load change equal to current rating):	0.0005% + 100 μV	0.0005% + 50 μV

Current (with load voltage change equal to voltage rating of supply): 0.01% of output level + 0.5 mA.

LINE REGULATION (for source voltage change from 104 to 127 Vac or 208-254 Vac at any output voltage or current within rating)

	6104A and 6114A	6105A and 6115A
Voltage:	0.0005% + 40 μV	0.0005% + 100 μV
Current:	0.005% + 40 μA	0.005% + 20 μA

RIPPLE AND NOISE (at any line voltage and load within ratings)

Voltage: 40 μV rms, 100 μV p-p (10 mV p-p with 400 Hz source).
Current: 0.2 mA rms, 1 mA p-p.

TEMPERATURE COEFFICIENT (per degree C)

	6104A	6105A	6114A and 6115A
Voltage:	0.005% + 25 μV	0.005% + 50 μV	0.001% + 15 μV
Current:	0.02% + 50 μA	0.02% + 25 μA	

LOAD TRANSIENT RECOVERY (time to recover within 10 mV of selected output level following load current change equal to supply's current rating): <50 μs

METER ACCURACY: ±2%

DRIFT (under constant line, load, and ambient conditions)

	6104A and 6105A	6114A and 6115A
Voltage, 8-hour:	0.005% + 50 μV*	0.0015% + 15 μV†
Voltage, 90-day (tentative spec):	0.01% + 100 μV*	0.0075% + 30 μV†
Current, 8-hour:	0.25% + 7 mA	0.25% + 4 mA

* Pot wiper effect may add 5 mV to 6104A or 10 mV to 6105A.
† With 5th digit set to zero. Otherwise, pot wiper effect may add 200 μV.

PROGRAMMING COEFFICIENTS

	Resistance programming	Voltage programming
Voltage:	2000 Ω/V ±0.01%	1 V/V ±0.2 mV
Current (6104A, 6114A):	500 Ω/A ±0.25%	0.5 V/A ±1.0%
Current (6105A, 6115A):	1000 Ω/A ±0.25%	1 V/A ±1.0%

PROGRAMMING SPEED

		6104A, 6114A	6105A, 6115A
From zero up to within 99.9% of max rated output voltage:	No load	60 ms	150 ms
	Full load	200 ms	500 ms
From max rated output voltage down to less than 0.1% of that voltage:	No load	600 ms	1.5 s
	Full load	100 ms	175 s

OVERVOLTAGE PROTECTION CROWBAR

Trip voltage range: 0.5 V to 10% above max rated output

POWER INPUT: 104-127 or 208-254 Vac 48-440 Hz, 150 VA max.

DIMENSIONS: 7¼ in W x 6½ in H x 13¼ in D (197 x 166 x 336 mm)

WEIGHT: 17 lbs (7,7 kg)

PRICES in the U.S.A.:

6104A: \$440. 6114A: \$525.
6105A: \$455. 6115A: \$540.

MANUFACTURING DIVISION: NEW JERSEY DIVISION

Green Pond Road
Rockaway, New Jersey 07866



George G. Emmermann

Arriving in Florida from his native Cuba in 1959, George Emmermann studied at the Massey Technical Institute while working for a marine radio firm. From there it was to a New Jersey firm as a senior laboratory technician and study at the Newark College of Engineering. Graduating cum laude with a BSEE in 1969, he came to work for HP's New Jersey Division. Under the HP Honors Co-op program, George earned his MSEE degree at NCE in January of this year. He is a member of the IEEE.

George's caribbean blood never did adjust to northern climates, however, so he returned to Florida with his wife (also a Cuban emigré) and two-year-old son. He now designs weather radars for an avionics firm. For once he has a chance to take up tennis, an activity that academics hadn't allowed time for.

HEWLETT-PACKARD JOURNAL
NOVEMBER 1972 Volume 24 • Number 3



*Technical Information from the Laboratories of
Hewlett-Packard Company, 1501 Page Mill Road,
Palo Alto, California 94304 U.S.A.
Hewlett-Packard S.A., 1217 Meyrin—Geneva, Switzerland
Yokogawa-Hewlett-Packard Ltd., Shibuya-Ku, Tokyo 151 Japan*

Editorial Director: Howard L. Roberts
Managing Editor: Richard P. Dolan
Contributing Editors: Ross H. Snyder, Laurence D. Shergalls
Art Director, Photographer: Arvid A. Danielson
Art Assistant: Erica R. Helstrom
Administrative Services: Ruth G. Ross

HP Archive

This vintage Hewlett-Packard document was
preserved and distributed by

www.hparchive.com

Please visit us on the web!

On-line curator: John Miles, KE5FX

jmiles@pop.net

