

SEPTEMBER 1972

HEWLETT-PACKARD JOURNAL



Logic Pulser and Probe: a New Digital Troubleshooting Team

A new Logic Pulser in a probe package injects pulses onto digital circuit nodes without disconnecting IC outputs. A new Logic Probe detects pulses, high and low levels, and open circuits or bad levels.

By Robin Adler and Jan R. Hofland

THE WIDESPREAD USE OF DIGITAL INTEGRATED CIRCUITS presents a host of new challenges to electronic troubleshooters. Techniques for finding failures in analog circuits are well understood but not very useful in the digital world. There has also been a scarcity of instrumentation specifically designed for testing digital circuits.

Stimulus/response techniques, a mainstay of analog troubleshooting, illustrate the problem. A small signal is inserted at a circuit node and the response is monitored at various points downstream. The point at which the signal disappears or becomes distorted gives a good indication of the fault location.

Applying stimulus/response techniques to digital circuits has, up to now, been impractical. Digital outputs are intentionally designed with low output impedances to make them insensitive to noise. In a complete system every input is connected to a low-impedance output, which clamps it in either a high or low logic state. The only method of injecting arbitrary pulses into a given IC input has been to unsolder the output driving it or to cut the printed-circuit trace leading to it. No convenient non-destructive means of providing arbitrary in-circuit stimulus to IC's on digital boards has existed.

Now, two new instruments make stimulus/response testing of digital circuits not only possible but easy (see Fig. 1). Model 10526T Logic Pulser automatically injects a pulse of the proper polarity anywhere in a TTL or DTL circuit. Model 10525T Logic Probe detects logic levels and pulses, like its predecessor, the 10525A Logic Probe¹. In addition, the new Probe can distinguish bad levels and open circuits. It also incorporates improvements in speed, input impedance, reliability, and input protection.

Pulser Is First of Its Kind

The Logic Pulser is a new development in digital instrumentation. It will superimpose digital pulses onto circuit nodes with no need to unsolder pins or cut printed-circuit traces even when the nodes are being clamped by digital outputs.



Cover: *The two subjects on this month's cover are symbolic of the broad range of Hewlett-Packard's electronic test capabilities. The Logic Pulser on the right simplifies checkout of microcircuit logic, right down to the individual gate. The Microwave Link Analyzer on the left checks out the performance of communications macrocircuits, all the way up to systems that span the world via satellite.*

In this issue:

- Logic Pulser and Probe: A New Digital Troubleshooting Team, by Robin Adler and Jan R. Hofland* **page 2**
- A New Microwave Link Analyzer with High-Frequency Test Tones, by Reid Urquhart* **page 8**
- Microwave Radio Communications and Performance Measurements, by John Fisher* **page 10**
- MLA Measures RF Performance with Down Converter, by Michael Crabtree* **page 17**
- Communications-Oriented Microwave Solid-State Sweeper, by Arlen E. Dethlefsen* **page 19**

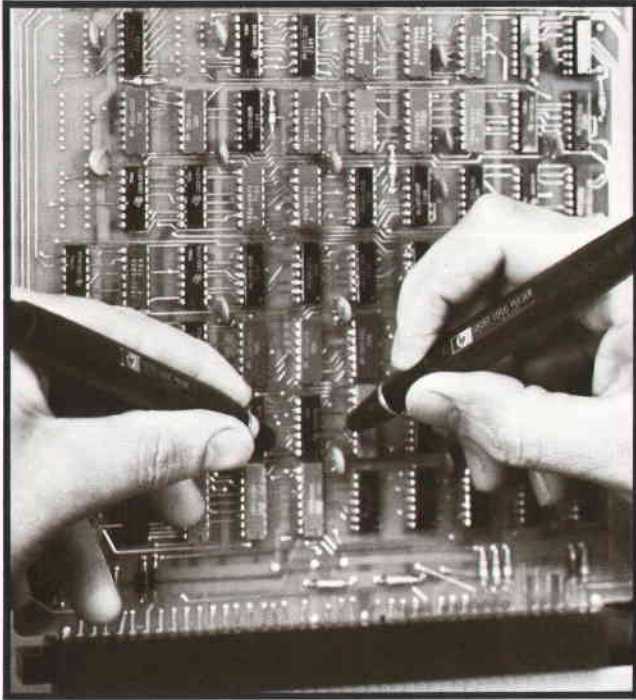

Fig. 1. *In-circuit stimulus/response testing of digital integrated circuits, once impractical, is now easy. New Model 10526T Logic Pulser (right) briefly drives any TTL or DTL node to its opposite state. Model 10525T Logic Probe (left) checks the circuit's response.*

The Logic Pulser is a single-shot, high current pulse generator packaged in a hand-held probe. It can source sufficient current to force low outputs out of saturation to a high state and sink sufficient current to pull normally high outputs below the logic zero threshold.

Actuation is by means of a pushbutton switch on the probe body. When the switch is pressed, a single high-going or low-going pulse approximately $0.3\mu\text{s}$ wide is delivered to the circuit under test. Pulse polarity selection is automatic—high nodes are pulsed low and low nodes are pulsed high each time the button is pressed. When not pulsing, the output tip of the Pulser is in a high-impedance third state so that circuit operation is not affected by probing.

Driving a TTL/DTL output out of saturation requires high current, but the short duration of the pulse, coupled with the low pulse repetition rate of manual actuation, limits the average power dissipation to miniscule amounts and assures that the driven device is protected.

Probe Measures Response

The Logic Pulser provides the signal injection necessary for stimulus/response troubleshooting.

The system's response to the pulser-applied signals is monitored with the Model 10525T Logic Probe.

This new TTL/DTL Probe is designed for detecting and indicating logic signals in digital systems. It detects valid high and low logic levels, open circuits and voltages in the bad-level region between the logic thresholds, pulses down to 10ns in width, and pulse trains to greater than 50 MHz. All information is displayed by a single indicator light in the probe tip.

The Probe is simple to use. With the probe tip open-circuited the display lamp will be at half brilliance, indicating a bad level or an open circuit. When touched to a circuit point where there is a steady logic level, the lamp goes to full brilliance for a logic high or extinguishes to indicate a logic low. If the probed node is at an invalid level—for example, an open TTL input—the lamp remains at half brilliance.

The Probe is particularly valuable for monitoring single-shot or repetitive pulses. Pulse trains to greater than 50 MHz are indicated by a flashing light. Single pulses, virtually impossible to view with conventional oscilloscopes, are captured by the Probe and stretched for a clearly visible blink of the lamp. The lamp flashes on for high-going pulses and blinks off for low-going pulses.

The Probe's response to various input signals is summarized in Fig. 2.

Using the Logic Probe won't affect the circuit under test because its input impedance is greater than $25\text{ k}\Omega$ at either logic level. Its input characteristics are similar to one low-power TTL load.

Inadvertent probing of high-voltage points won't damage the Probe. Its input is protected against overloads to ± 70 volts continuous and ± 200 volts intermittent. The Probe may even be touched to the 120-volt ac power line for 30 seconds; it will respond with a blinking light to indicate the 50 or 60 Hz line frequency.

Troubleshooting Methods

There are probably as many ways to use the Logic Probe and Pulser as there are users. In one method, the Probe is used first to detect the absence of key signals such as clock, start, shift, reset, or enable. This isolates the failure to a small group of IC's. With a rough idea of the location of the failure, the internal clock is removed and the Pulser is used to supply stimuli to individual packages. Gate operation is verified by pulsing inputs and checking for transmitted pulses at the output. Flip-flops are checked for proper responses to

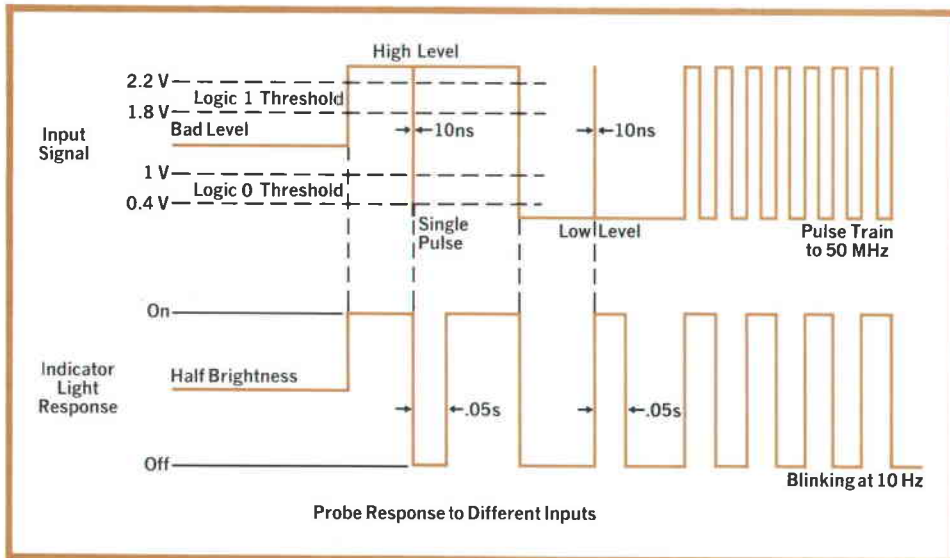

Fig. 2. Lamp at the tip of Model 10525T Logic Probe is at half brightness for an open circuit or bad logic level, at full brightness for a steady logic high level, and off for a steady logic low: Pulses and pulse trains cause the lamp to blink.

stimuli applied at the clock and preset inputs. A decade or binary counter can be checked with the Pulser applying count pulses and the Probe monitoring the progression of output states. With Pulser and Probe providing stimulus and response, the truth tables of suspected packages are easily checked.

When a failure is located, Probe and Pulser can be used on the same node to aid in its identification. A Probe display of a steady logic low when the Pulser is driving the node indicates a short to ground. The situation is analogous for a short to V_{cc} .

Another troubleshooting technique uses the Pulser to aid in preliminary fault isolation. A long series of logic circuits can be checked by pulsing one end and monitoring effects far down the chain. If the pulse is not properly transmitted, the same technique can be used on each half of the chain. Continued iterations will isolate the failure.

For example, the count and display circuitry of a digital counter can be checked using this technique (see Fig. 3). Reset the counter and pulse the clock input of one of the IC's in the counting chain one or more times. After the clock input of the display latch is pulsed, the corresponding display digit should read the number of pulses applied to the IC counting decade. If the proper number isn't displayed, the Probe and Pulser are used to isolate the failure to the decade, latch, decoder or display. A correct display reading indicates the problem is somewhere else.

The new bad-level/open-circuit detection capability of the Logic Probe lends itself to checking TTL systems that have three-state outputs. The

three-state output can be in a logic high or logic low state like a conventional TTL output, or it can be in a high-impedance third state, unable to sink or source any current. The Probe will detect this third state and indicate it as an open circuit. Bad-level/open-circuit detection is also useful for locating failures due to broken bonds, which are responsible for a high percentage of IC failures. When a bond breaks on an output pin it leaves the input of the IC connected to it open-circuited. The input will float to approximately 1.4 V and the Probe will respond with a bad-level indication.

Use with Clip and Comparator

The Logic Pulser also complements the 10528A Logic Clip² and 10529A Logic Comparator.³ The Clip attaches to 14- and 16-pin dual-in-line packages and simultaneously indicates the states of all pins. Used with the Pulser, the Clip is handy when responses at several output pins are of interest.

The Comparator is a fault isolation device that compares a known-good reference IC with a test IC of the same type. When testing sequential logic, the test and reference IC's must be synchronized to the same state before the comparison is made. When reset pulses are not provided, the Logic Pulser will provide the necessary synchronization pulse.

Logic Probe Design

Most of the circuitry in the Logic Probe is in a single custom bipolar integrated circuit—the main reason that everything fits into the Probe's one-fourth-cubic-inch internal volume. The Probe's

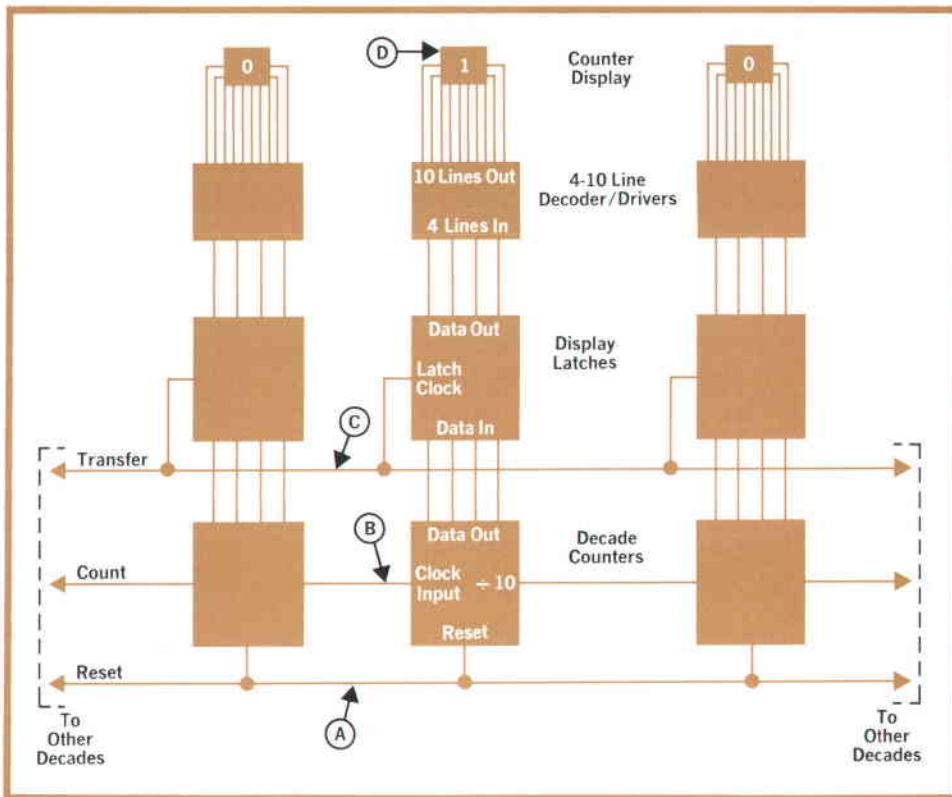

Fig. 3. Here's how the Logic Pulser simplifies troubleshooting an electronic counter. A) Clear all circuits by pulsing the reset line or by pushing the front-panel reset button. B) Pulse the clock input of a selected decade counter one or more times. C) Transfer data to the display latch by pulsing the latch clock input. D) Display should read the number of pulses entered. If it doesn't, use the Pulser, Probe, and Clip to isolate the trouble.

features lend themselves very nicely to integrated circuit technology. For instance, the Probe must respond quickly to the beginning of a pulse but it doesn't have to respond immediately to the end of the pulse because the indication is being stretched much longer than the pulse duration anyway. Because of this no special IC processing techniques had to be used. In fact, the stretching inherent in transistors which are slow to turn off is an advantage.

The Probe block diagram is shown in Fig. 4. There are two channels, one for detecting high logic levels and one for detecting low levels. The two channels are similar, so only the logic-high channel will be described. In the absence of a valid logic high at the input, the output of the threshold detector is low and the set input of FF1 is high. Feedback from the output of FF1 to the reset input results in the output being low and Q2 being off. When a valid logic high occurs the threshold detector goes high and sets FF1, provided that Gate G1 is enabled by G2. G2 disables G1 if the logic-low channel is stretching a pulse and if it senses a valid logic low level. When the output of FF1 goes high, the output is delayed and inverted by G3, G4, and C1 and applied to the reset input to reset the flip-flop at the end of the stretching period. The set input of FF1 overrides the reset input

in the case of a steady logic high level to keep Q2 on as long as the level is present. In the absence of either a logic high or a logic low, Gate G9 will turn Q1 on to indicate a bad level. Diode D1 reduces the voltage drop across the lamp when Q1 is on, resulting in a dim indication for bad-level/open-circuit conditions.

Pulser Design

The Logic Pulser has the apparent ability to distinguish between high and low levels and always pulse with the proper polarity. Here's how it works. When the switch is actuated the output is clamped low for $0.3 \mu\text{s}$ and then driven high for $0.3 \mu\text{s}$. If the driven node is at a logic low level, nothing happens when the Pulser output clamps low, and a single positive pulse is delivered when the Pulser output goes high. If the driven node is originally in the high state the reverse is true.

Fig. 5 is a block diagram of the Pulser circuitry. Signals from the pulse button are first shaped by an RS flip-flop. The single pulse from the flip-flop is shortened to $0.3 \mu\text{s}$ by a one-shot multivibrator and applied to the low-level amplifier. The output is clamped low for the duration of the pulse. The trailing edge of the pulse triggers a second one-shot multivibrator and a second $0.3 \mu\text{s}$ pulse is generated. The second pulse is applied to the high-level

Two Troubleshooting Kits

The new Logic Pulser and Logic Probe are the latest in a series of HP instruments dedicated to in-circuit troubleshooting of integrated circuits. Two of the earlier instruments, Model 10529A Logic Comparator and Model 10528A Logic Clip, are available with the Probe and Pulser in two new kits capable of solving a multitude of fault-isolation problems in digital circuits. The kits allow the user to profit from the basic synergism of the component instruments: the IC troubleshooters are designed to work together and are considerably more effective for fault isolation when used together.

The 5015T Kit consists of a 10528A Logic Clip² in addition to a Logic Probe and Pulser. These three instruments are a good combination for in-circuit, stimulus-response testing of TTL and DTL integrated circuits. The Clip attaches to 14 and 16 pin dual-in-line packages and gives a static indication of the logic state of all pins. It is self-powered, automatically seeking V_{cc} and ground on the pins of the test IC and drawing its power from them.

The Clip's multi-pin response-monitoring capability complements the Pulser's capability for arbitrary stimulus. The Pulser-Clip pair is especially useful for testing sequential circuits, such as flip-flops, counters, and shift registers. With the Clip attached to the test IC the Pulser is used to supply clock, reset, count, or shift pulses to step the device through

its output sequence. After each pulse the total output state of the device is displayed on the Clip. Failure of the IC to follow its prescribed sequence is easy to see.

The 5011T Kit adds a 10529A Logic Comparator³ to the three instruments of the 5015T Kit. The Comparator is a hand-held instrument that functionally tests in-circuit TTL and DTL IC's.

The Comparator borrows power and input signals from the test IC and applies them to a reference IC of the same type that is inserted into the Comparator. The outputs of test and reference IC's are compared, and any differences in logic state greater than 200 ns in duration are displayed as errors by one of sixteen light-emitting diodes, each of which corresponds to one of the 14 or 16 pins of the test IC. A lighted diode indicates the output pins of the test IC where the logic states disagree with those at corresponding pins of the reference IC. Differences in logic state less than 50 ns are ignored so that propagation-delay variations are not indicated as errors. Differences greater than 200 ns are stretched to assure a visible flash.

Once the Comparator has localized a failure to a node the Probe and Pulser can analyze the failure for its cause. The Probe can indicate total lack of pulse activity at a node and Probe and Pulser together will determine if the failure is a short to ground or to V_{cc} .

amplifier which holds the output high for 0.3 μ s.

After the trailing edge of the positive output pulse, 0.6 μ s following switch closure, both output amplifiers are off. In this state the impedance seen looking back into the Pulser's output is greater than

1 M Ω for logic-level signals.

When driving a low node out of saturation, the Pulser can source at least 650 mA. The necessary charge is capacitively stored in the Pulser, which never draws more than 25 mA.

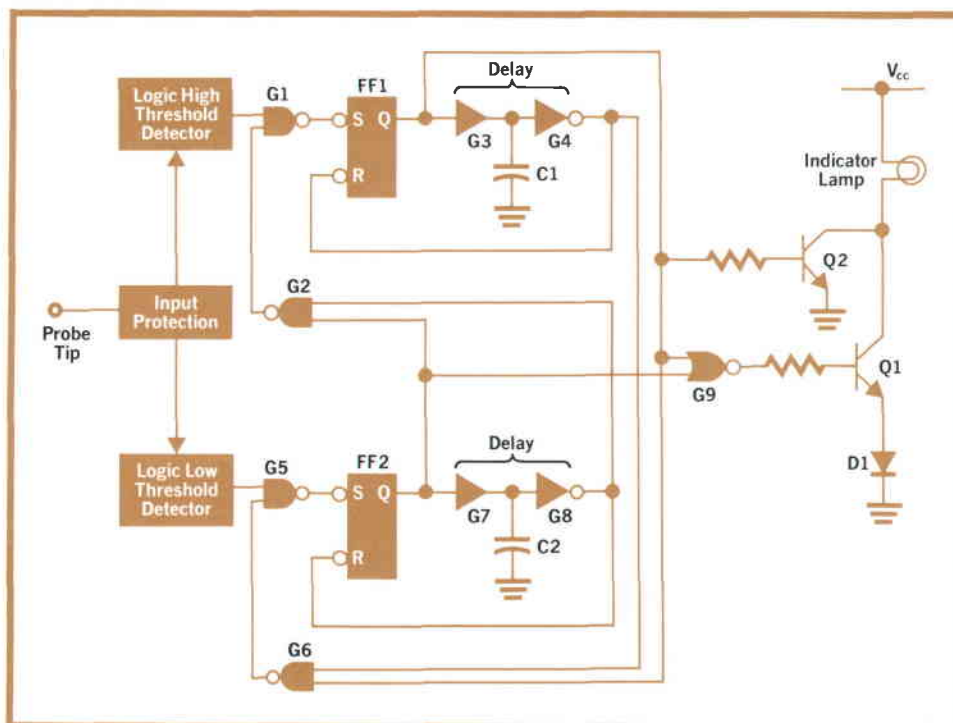

Fig. 4. Logic Probe stretches pulses 10 nanoseconds wide or wider to give a clearly visible blink of its lamp.

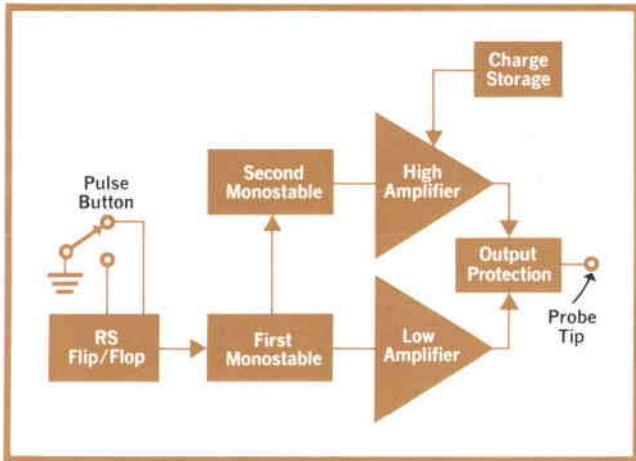

Fig. 5. Logic Pulser sinks or sources 650 milliamperes for 0.3 microseconds. Duration is short enough so high pulse energy doesn't damage integrated circuits.

Acknowledgments

Our thanks are extended to Chuck Taubman and Gary Gordon for guidance and support throughout the development. Jesse Pipkin and Howard Mar-

shall contributed to the basic idea behind the Pulser. Alex Au provided considerable assistance with the Probe IC design. Jim Marrocco and David Goelz ably handled mechanical and industrial design. Roy Criswell introduced both instruments to production.

References

1. G. B. Gordon, "IC Logic Checkout Simplified," Hewlett-Packard Journal, June 1969.
2. "Deftly Designed—The Logic Clip," EDN, March 1, 1970.
3. M. Baker and J. Pipkin, "Clip and Read Comparator Finds IC Failures," Hewlett-Packard Journal, January 1972.

SPECIFICATIONS

HP Model 10526T Logic Pulser

OUTPUT HIGH PULSE VOLTAGE: > 2 V at 0.65 A
(1A typical at $V_{ps} = 5$ V, 25°C).

OUTPUT LOW PULSE VOLTAGE: < 0.8 V at 0.65 A
(1A typical at $V_{ps} = 5$ V, 25°C).

OUTPUT IMPEDANCE (active state): < 2 ohms.

OUTPUT IMPEDANCE (off state): > 1 Megohm.

PULSE WIDTH: 0.3 μs nominal.

INPUT OVERLOAD PROTECTION: ± 50 volts continuous.

POWER SUPPLY INPUT PROTECTION: ± 7 volts
(includes power lead reversal protection).

POWER REQUIREMENT: 5 V $\pm 10\%$ at 25 mA.

TEMPERATURE: 0°C to 55°C .

ACCESSORIES INCLUDED: BNC to alligator clips, ground clip.

PRICE IN USA:
Model 10526T, \$95.00.
Please consult HP on larger quantities.

HP Model 10525T Logic Probe

INPUT IMPEDANCE: 25 k Ω (V_{in}/I_{in} characteristic similar to low power TTL).

LOGIC ONE THRESHOLD: 2.0 V ± 0.2 V.

LOGIC ZERO THRESHOLD: 0.8 V $+0.2$ V, -0.4 V.

INPUT MINIMUM PULSE WIDTH: 10 ns (5 ns typical).

INPUT MAXIMUM PULSE REPETITION FREQUENCY: > 50 MHz.

INPUT OVERLOAD PROTECTION: ± 70 volts continuous, ± 200 volts intermittent, 120 V ac for 30 seconds.

POWER REQUIREMENTS: 5 V $\pm 10\%$ at 100 mA, internal overload protection for voltages from $+7$ to -15 volts. Includes power lead reversal protection.

TEMPERATURE: 0 to 55°C .

ACCESSORIES INCLUDED: BNC to alligator clips, ground clip.

PRICE IN USA:
Model 10525T, \$95.00.
Please consult HP on larger quantities

MANUFACTURING DIVISION: SANTA CLARA DIVISION
5301 Stevens Creek Boulevard
Santa Clara, California 95050



Robin Adler (RIGHT)

Robin Adler joined HP in 1970, the same year that he received his B.S. degree in electrical engineering from California Institute of Technology. After two years of digital design he became project leader for the 10526T Logic Pulser. His name is one of four on an application for a U.S. patent on the Pulser. After a recent change of job function he is still in the logic testing business, but in marketing instead of design. Away from HP, Robin divides his time between outdoor activities like camping, skiing, and sailing, and furthering his engineering education with part-time course work at Stanford University.

Jan R. Hofland (LEFT)

Jan Hofland, project leader for the 10525T and 10525H Logic Probes, is a graduate of the University of Washington. After receiving his B.S.E.E. degree in 1965, he spent five years in the U.S. Navy working on nuclear propulsion systems. He then returned to the campus, this time to Stanford University, and received his M.S.E.E. degree in 1971. He came to HP the same year. These days many of Jan's spare hours are being spent "making a newly acquired home habitable according to our personal tastes." In that project, Jan's woodworking skills are undoubtedly getting a good workout.

A New Microwave Link Analyzer with High-Frequency Test Tones

Microwave link nonlinearities yield their secrets to high-frequency test tone probing. Agreement can now be obtained between swept measurements and white noise tests.

By Reid Urquhart

THE FINAL ACCEPTANCE TEST of any microwave link system involves the measurement of the amounts of thermal and intermodulation noise introduced between baseband input and output. Thermal noise, of course, can be measured at the baseband output with no input, but to measure intermodulation noise, some test signal must be applied. The signal usually chosen is band-limited white noise, the band being the same as the system under test, which simulates the normal working baseband signal.

White Noise Testing

First, a specified power level of white noise is connected to the baseband input and the noise power at the output is measured with a meter whose measurement bandwidth is equivalent to one telephone channel. The meter can usually be tuned to any one of several specified bands in the baseband spectrum. Second, a bandstop filter, also with bandwidth equivalent to a telephone channel and tuned to the same frequency as the receiver, is inserted in series with the noise source output. The power is measured again and the ratio of noise power without bandstop filter to noise power with filter is calculated. This quantity is known as the NPR, i.e. Noise Power Ratio.

This test, usually known as the 'white noise test' is a useful measure of overall system performance since the noise input simulates normal baseband signals. It has, however, a major drawback since it lumps together the effects of all the link nonlinearities, whether they occur at baseband, IF or RF. Thus the test indicates only whether the link is working according to specification. It gives neither diagnostic information nor adjustment guidance.

Sources of Nonlinearities Identified

The new HP Microwave Link Analyzer measures nonlinear effects in the various components of a microwave link, so the sources of intermodulation noise may easily be identified. As well as the more usual tests of group delay distortion and linearity, using low-frequency test tones, the new MLA measures both differential phase and differential gain with a range of high-frequency tones. This differential phase and gain measurement capability, in contrast to that available in earlier instruments, can be used for IF as well as baseband measurements, with test tones up to and including 5.6 MHz. Thus the link may be fully characterized so that accurate predictions of NPR can be made. The complete measurement capability of the new HP MLA reduces the need for time-consuming white noise tests and provides, in the same measurement, diagnostic and adjustment information for link optimization.

Elements of the MLA System

The new MLA (Fig. 1) consists of an IF/BB Transmitter, an IF/BB Receiver, and four plug-ins—two for the Transmitter and two for the Receiver. The 3710A is the Transmitter mainframe containing the sweep and IF sections while the 3715A and 3716A are test tone oscillators that form the baseband section of the transmitter. The 3715A generates three low-frequency test tones, 83.3, 250, and 500 kHz. The 3716A, in addition to the low tones, provides frequencies of 2.4, 3.58 or 4.43, 5.6, and 8.2 MHz.

Measurements are performed with the 3702B Receiver mainframe and its differential phase detector plug-ins, the 3703B and 3705A, which correspond with the two transmitter plug-ins. The 3703B mea-

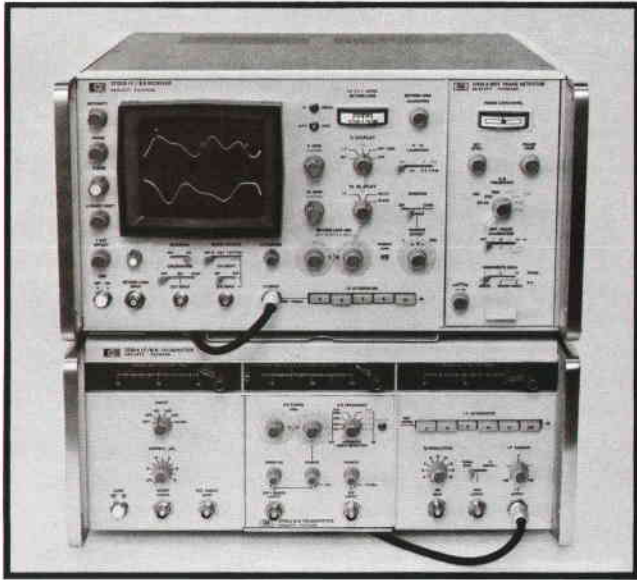

Fig. 1. HP Microwave Link Analyzer consists of 3710A IF/BB Transmitter (bottom) and 3702B IF/BB Receiver.

measures group delay distortion at the three low frequencies and the 3705A in addition measures differential phase with the four higher frequencies.

Methods of Measurement

In the new MLA all measurements of nonlinearity, whether at baseband or IF, are performed with two signals. The first is a low-frequency, high-level signal intended to sweep the system over its working range (hence known as the sweep signal) and the second is a much lower level, higher (but fixed) frequency signal known as the test tone. Nonlinearities present in the link under test cause the test tone to be modulated, both in amplitude and phase, at the sweep rate. Nonlinear amplitude response will cause the test tone to be amplitude-modulated while nonlinear phase results in phase modulation. When testing is being carried out from baseband to baseband, the input signal consists of the sum of sweep and test tone. The receiver filters the resulting signal to remove the sweep and, by amplitude and phase demodulation of the test tone, measures the nonlinearities in the amplitude and phase characteristics of the link.

In the case of IF tests, the link input signal is generated within the MLA by using the baseband-plus-sweep signal to frequency-modulate a 70 MHz carrier. The sweep causes the carrier to traverse the IF band (up to a maximum of ± 25 MHz about 70 MHz) while the test tone produces low-deviation FM of the carrier.

In effect, for an IF test, the link's own modulator

is being replaced by a standard one contained in the 3710A IF/BB Transmitter; the link's demodulator is replaced by a standard in the 3702B IF/BB Receiver.

It is a frequent requirement in testing that the MLA transmitter and the receiver be remote from each other—at opposite ends of a link, for instance—connected only by the channel under test. Thus, the 3702B IF/BB Receiver must be able to recover all the necessary information for the measurement from the test signal itself. Sweep is recovered either by filtering, if the input is at baseband, or by a tracking discriminator if the input is at IF, while the test tone is demodulated in the same discriminator.

Phase modulation of the test tone cannot be interpreted as phase since no reference is available; only variations in phase can be displayed. The test tone is applied to a phase locked loop and, as explained in the appendix, the output of the loop is proportional to variations in group delay.

Transmitter Design

As already mentioned, when doing IF measurements the transmitter is effectively replacing the link's own modulator with a standard. To make useful measurements this standard modulator must be at least an order of magnitude more linear than the one it replaces. This is achieved by taking advantage of the composition of the test signal. In Fig. 2, the 3710A Block Diagram, it can be seen that the sweeping IF output is obtained by mixing two UHF oscillators, one at 440 MHz which is frequency modulated by the test tone, the other sweeping between 345 and 395 MHz. Thus sweep and test tone cannot interact on the potentially nonlinear tuning characteristic of a voltage-controlled oscillator. The only components in the system which can cause intermodulation are the mixer and the output amplifier. The mixer introduces a negligible amount while the output amplifier has some group delay which is equalized by a standard all-pass network. The UHF oscillator frequencies are chosen to give small enough fractional bandwidth for reasonably linear tuning and also to minimize in-band spurious mixer signals, since the measurement end of the MLA is an extremely sensitive detector of such signals.

It is important in link measurements that both the flatness and frequency stability of the IF output signal be good. This is achieved in the 3710A with a frequency feedback loop controlled by a highly linear and temperature-stable pulse count discriminator and an automatic level control loop. The AFC loop also controls the linearity of the sweep, since the VCO is forced to follow the linear characteristic of the discriminator. The system achieves a fre-

(Text continued on page 12.)

Microwave Radio Communications and Performance Measurements

Microwave radio now forms the backbone of worldwide communications. To maintain peak performance, microwave radio equipment requires frequent performance measurements. The Microwave Link Analyzer is designed to make these measurements so that microwave radio links can be optimized for maximum traffic density with minimum distortion.

Microwave communications begins with the need to transmit a baseband (BB) signal. This signal may contain several hundred telephone channels multiplexed together, or a television channel, or some type of data. In the typical microwave link, shown in Fig. 1, the BB signal frequency modulates an intermediate-frequency (IF) carrier. The IF signal is amplified and then converted to microwave radio frequencies (RF) for transmission. The RF signal is obtained by mixing with a local oscillator and filtering one sideband for transmission.

Bandwidths and frequencies for the BB, IF, and RF signals are standardized internationally. Take, for example, a 6 GHz radio channel carrying 1800 telephone channels. The 1800-channel BB signal would be in a frequency range of 0.3 to 8.2 MHz. The IF center frequency would be the standard 70 MHz, and the IF and RF bandwidths would be 30 MHz, also standard. Thus the IF signal would be in the range 55 to 85 MHz and the RF signal (assuming the upper sideband is transmitted) would be in the range 6055 to 6085 MHz.

At the receiver the RF signal is converted back to IF and amplified to bring it up to a nominal 0.5 V rms working level. Automatic gain control is used to reduce level variations caused by changing propagation conditions. An amplitude limiter then removes noise and amplitude variations, and an FM demodulator reproduces the original BB signal, which is amplified to the required level.

Although Fig. 1 shows only one transmitter and one receiver, most links also have repeater stations between these two end points. This is because such links are op-

erated line-of-sight and also because microwave signals undergo rapid attenuation in the earth's atmosphere, limiting each hop to 30 miles or less. At each repeater the received RF signal is converted to IF, amplified, reconverted to RF and retransmitted.

In a typical radio system the spectrum is often fully used and there may be several radio channels similar to the one described here, transmitting in both directions.

Distortions

In practical microwave radio systems, some distortion of the signals is inevitable. The sources of this distortion are non-ideal characteristics of various parts of the system: modulator/demodulator nonlinearity, IF amplitude response, IF group delay response, RF amplitude response, RF group delay response. All of these are functions of carrier frequency.

Modulator/demodulator nonlinearity. In frequency modulation the carrier frequency is deviated from a center frequency by a modulating voltage. Ideally, deviation is a linear function of modulating voltage. The slope of the voltage/frequency characteristic is the sensitivity of the modulator; it tells how much a change in input voltage will change the output frequency. Practical modulators are never perfectly linear. Typically they become less sensitive as deviation increases and unless the demodulator characteristic exactly compensates for this nonlinearity, distortion will occur. For good transmission the overall modulator/demodulator characteristic should be linear to within 1 or 2%.

Amplitude Response. IF amplitude response describes carrier amplitude variation as a function of carrier frequency. Ideally there would be no variation within the IF passband, but in practice circuits with bandpass characteristics do not treat all frequencies alike even within their passbands.

In FM the information is carried in the frequency (or phase)

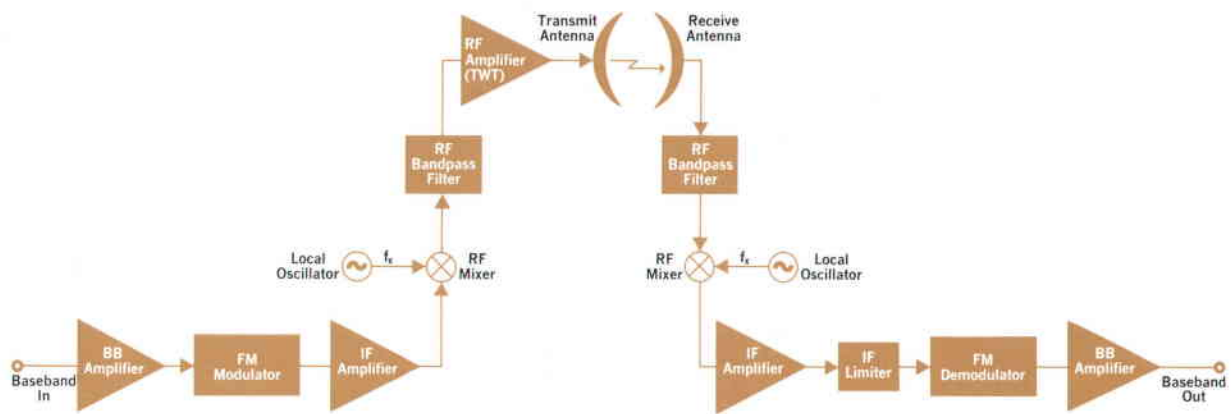

Fig. 1. Typical microwave radio link.

of the modulated carrier. It might seem, therefore, that amplitude variations with frequency would be unimportant, since any amplitude modulation could be removed by amplitude-limiting the signal before demodulation. In fact, it's important that IF circuits have a flat amplitude response for two reasons. First, if the amplitude variations are higher than second-order (e.g. cubic), then the modulation index of the carrier is so modified that it cannot be restored even with subsequent limiting. Second, and perhaps more significant, many nonlinear devices convert amplitude modulation (AM) into phase modulation (PM). Examples of such devices found in microwave links are mixers and traveling-wave tubes. If these follow circuits that have introduced amplitude modulation, then AM-to-PM conversion occurs, distorting the FM signal. Therefore, it's important that any amplitude variations be minimized before the signal enters such devices. Although amplitude limiters can be used to achieve this, they too are highly nonlinear and may act as AM-to-PM converters to a lesser extent.

Because the RF signal is identical in structure to the IF signal, what has been said about IF amplitude response applies equally well to RF amplitude response. Typical allowable amplitude variations before limiting are less than 0.5 dB for first or second order variations and less than 0.1 dB for higher orders.

Group delay response. IF group delay response describes phase nonlinearity as a function of intermediate frequency. Ideally, phase is a linear function of frequency and the group delay response—the slope of the phase characteristic—is constant with frequency. Distortion occurs if this delay is not the same for all frequencies. In typical systems each device might add 2 or 3 nanoseconds of delay variation and the entire system might have worst-case delay variations of 10 nanoseconds or more. Variations of this magnitude are intolerable, so group delay equalizers are used. Each equalizer attempts a reverse characteristic to the group delay of the circuits preceding it, thereby tending to cancel the distortions that would otherwise occur. Equalizers should be placed ahead of any devices capable of converting AM to PM; this is because equalization after such devices only cancels the group-delay variations and can't restore the distorted FM.

Similar considerations apply to RF group delay.

Measurement Techniques

To measure the characteristics of microwave radio links, swept-frequency techniques are generally used. A low-level

modulation test tone is swept over the frequency band of interest and the responses are obtained from the distortion the tone undergoes. Fig. 2 shows typical amplitude and group delay responses measured by an HP Microwave Link Analyzer.

Because of the phenomenon of AM-to-PM conversion, amplitude and group-delay measurements are often inadequate to characterize a link. Differential gain and differential phase are dynamic measurements that give a better picture of the distortions in the link. These measurements are also made by the Microwave Link Analyzer. The same technique is used, the intermodulation between the sweep signal and the test tone being measured in terms of amplitude and phase distortion of the test tone. For a low-frequency tone, say 500 kHz or less, these measurements are approximately equivalent to baseband linearity and IF/RF group delay measurements. However, as the test-tone frequency is increased, the effects of nonlinearities in the IF and RF sections become more apparent and the measurements give a much clearer picture of the distortions that will actually affect the wideband signals normally transmitted. Differential gain and phase measurements can be used to predict the intermodulation noise that would be produced in a loaded telephone system.

White-noise testing is another widely used method of predicting the performance of a loaded channel. A well-defined band of white noise simulates traffic and the noise power ratio in selected telephone channels is measured. This yields go/no-go criteria for the link, but doesn't identify or characterize the sources of distortion. Final acceptance of a link for maximum traffic density requires not only white noise testing but also Microwave Link Analyzer differential gain and phase measurements made between BB, IF, and RF terminals.

Microwave Link Analyzer measurements are treated in more detail in the accompanying articles, which describe several new HP instruments. Of particular significance is the new HP Microwave Link Analyzer's ability to make differential gain and phase measurements using *high-frequency* test tones. Only recently has theoretical and experimental work revealed that tests using such tones correlate much better with actual link performance than do the lower-frequency tests commonly used. The new Microwave Link Analyzer is the first instrument to put this new knowledge to work.

John Fisher

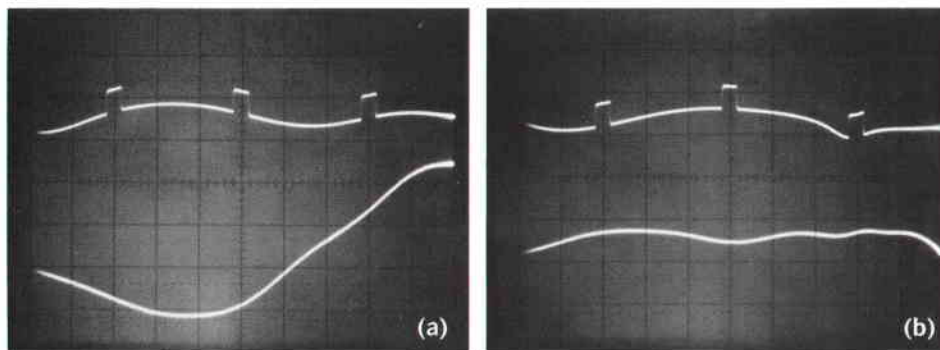

Fig. 2. Typical Microwave Link Analyzer displays for unequalized (a) and equalized (b) link. Top trace in each case is amplitude response (0.3 dB/cm). Bottom trace is group delay response (3ns/cm). Sweep is ± 10 MHz centered on 70 MHz. Markers on amplitude response are at 70 MHz ± 6 MHz.

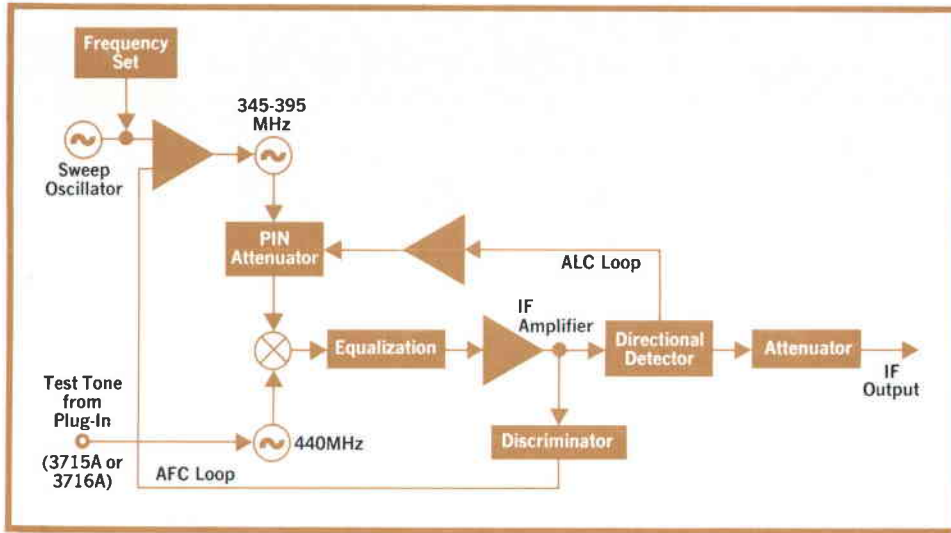

Fig. 2. 3710 IF/BB Transmitter mainframe contains sweep and IF sections. Test-tone oscillators are in 3715A and 3716A plug-ins (see Fig. 6).

quency stability of ± 500 kHz with less than one-half hour warm-up, and a sweep linearity of better than 1%.

The ALC uses a directional detector which controls a PIN diode attenuator operating on the output of the swept UHF oscillator.

The power flowing out of the 3710A is sampled in a directional coupler that is part of the directional detector shown in Fig. 2. It's important that the return loss at the output of the 3710A be high—at least 28 dB. Thus the coupler in conjunction with the IF amplifier output impedance (R_s in Fig. 3) must present an output impedance close to 75Ω . Power flowing out, P_o , causes current proportional to P_o to flow in the primary of T1 while reflected power, P_R , is applied to a balanced bridge consisting of R1, R2, R3 and R_s , with T1 connected across the equipotential corners of the bridge. Thus P_R causes no current in T1. T1 is a 1:1 transformer and the detector input impedance is 75Ω , so the input impedance of the coupler is also 75Ω . It appears therefore as a 75Ω matched 1.5 dB pad.

The sweep generator in the 3710A provides sine waves with good amplitude stability and harmonic distortion of about 0.4% in the frequency range 10 to 100 Hz. It also provides line-locked sine waves to the above specification in the range 45-65 Hz. The sweep generator uses a ten stage 'twisted ring' counter driving a digital-to-analog converter, with weighting resistors specially chosen so that its output is a stepped approximation to a sine wave containing high harmonics only. Low-pass filtering removes these high harmonics, giving a sine wave with the required purity. The counter is driven by a voltage-controlled oscillator (VCO) at 20 times the required output frequency. Normally it is driven

from a dc bias network but when line sweep is selected the VCO is phase locked to line with a sampling phase detector.

Receiver Design

The 3702B IF/BB Receiver accepts output signals from the link under test at baseband and IF and recovers sufficient information to display various link parameters against IF frequency on a CRT.

As in the case of the 3710A Transmitter, when the 3702B Receiver is being used at IF, it is effectively replacing the link demodulator by a standard which must be an order of magnitude more linear to perform useful measurements. As in the 3710A, advantage is taken of the composition of the test signal to achieve this. The incoming IF signal, which can sweep from 45 to 95 MHz, is mixed with a local oscillator to give an output of 17.4 MHz (Fig. 4). The

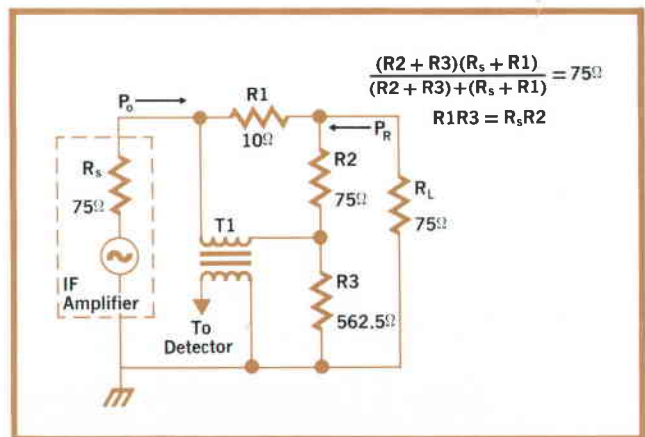

Fig. 3. Directional coupler (part of directional detector shown in Fig. 2) uses bridge circuit to optimize return loss at Transmitter output.

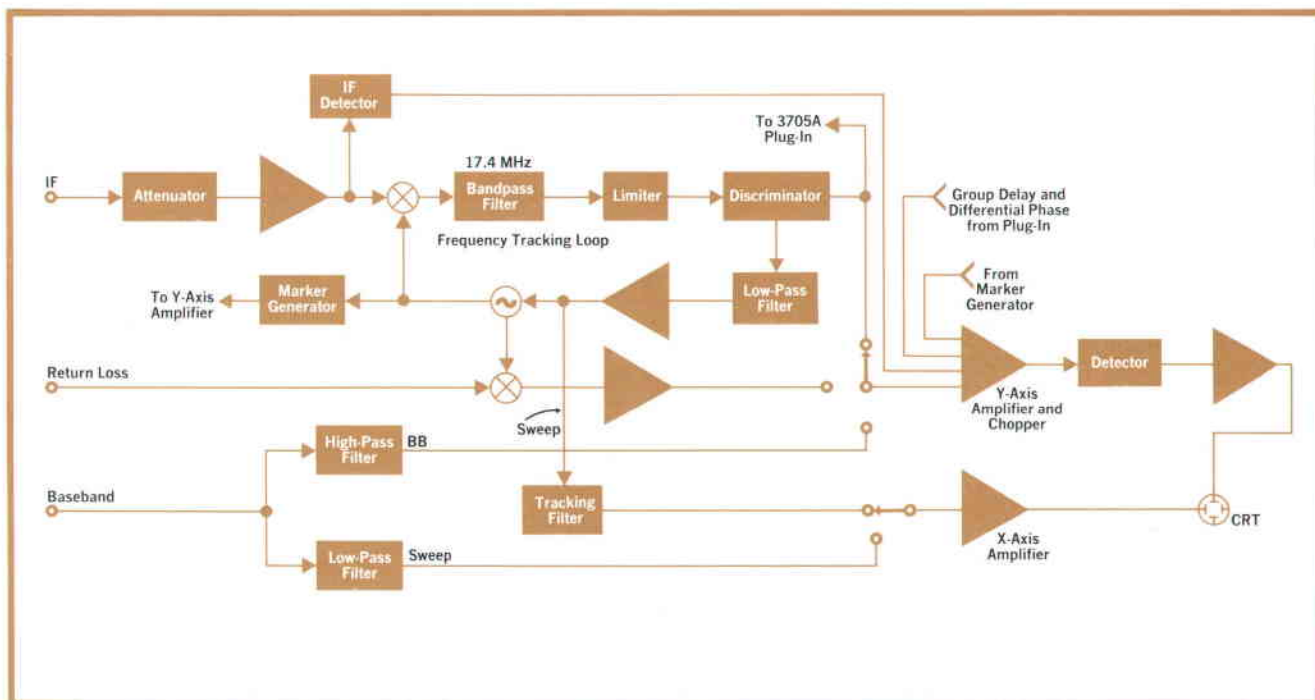

Fig. 4. 3702B IF/BB Receiver measures signals after transmission and displays link parameters on a CRT.

local oscillator is tuned in synchronism with the input signal, from 62.4 to 112.4 MHz, by the output of a frequency discriminator driven by the 17.4-MHz mixer output. These components, mixer, voltage-tuned local oscillator, and discriminator, thus form a frequency feedback loop with time constants so chosen that the local oscillator will track the incoming sweep frequency but not test tones.

Since the loop is of high gain (about 70 dB), the 50 MHz of incoming sweep is reduced to a residual 10 kHz at the 17.4 MHz IF, so the discriminator itself is only swept over this range. Therefore, its nonlinearities and the group delay of the preceding 17.4-MHz bandpass filter do not significantly affect the measurement.

A further advantage of the frequency-following loop is that the limiter, which must precede the 17.4 MHz demodulator, works at a constant and reasonably low frequency. This means that the effect of its AM-to-PM conversion coefficient is less significant, and gives a low overall conversion coefficient for the 3702B.

In addition to the input mixer, the local oscillator drives the return loss mixer and a marker generator which provides either a fixed comb of crystal-controlled markers at 2-MHz intervals or a fixed central 70-MHz marker with two symmetrical adjustable sliding markers, or both.

Return loss is measured with an external hybrid transformer which provides an output signal in the range 45 to 95 MHz. This signal, proportional to return loss, is mixed down to 17.4 MHz, amplified, detected, and displayed. Calibration is carried out with a standard known return loss.

The test-tone output signal from the discriminator is amplitude-demodulated in the 3702B to give a measure of linearity, and phase-demodulated in the 3705A plug-in to measure group delay.

If the 3702B is being used with a baseband input then sweep and test tone are separated by input filters and are then routed as if they had been derived from the demodulator.

The signal which controls the frequency of the 3702B's local oscillator is used to provide X deflection proportional to input frequency on the CRT. Since the oscillator control characteristic is nonlinear this signal is not a pure sine wave. In turn, this means that go and return traces on the screen are not superimposed. The sweep signal is therefore filtered by the active bandpass filter shown in Fig. 5, which automatically tunes itself to the particular sweep frequency being used. R1, R2, R3, C1 and C2 in conjunction with the operational amplifier form the equivalent of a simple tuned circuit whose center frequency is adjusted to R2. R2 is an optoelectronic variable resistor controlled by the output of a

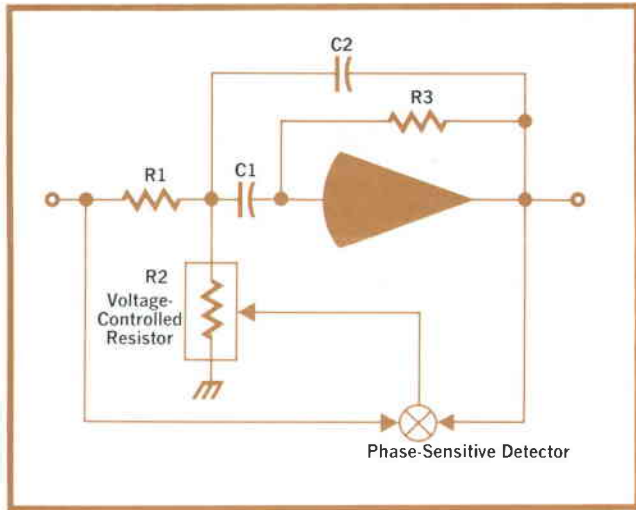

Fig. 5. Tracking filter in Receiver tunes itself automatically to the sweep frequency being used.

phase detector which adjusts R2 until the phase shift between input and output is zero degrees, thus tuning the filter to the input frequency.

The Plug-Ins

The test tone generators must provide frequencies that are stable both in the short and long terms. Short-term stability or phase jitter is important since it appears as noise on the trace. When making group delay or differential gain measurements, long-term and temperature stabilities are important because of the narrow loop bandwidths necessary in the phase detection plug-ins.

Fig. 6 shows a simplified block diagram of the

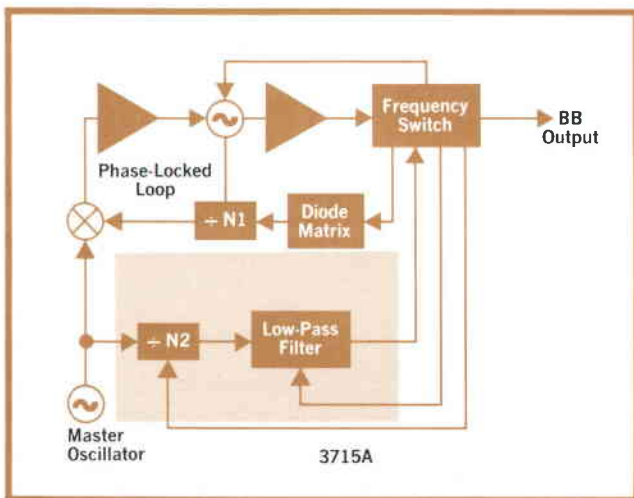

Fig. 6. Transmitter plug-ins generate test tones. 3715A (shaded) generates 83.3, 250, and 500 kHz tones. 3716A (entire diagram) generates high-frequency tones: 2.4, 3.58 or 4.43, 5.6, and 8.2 MHz.

3716A baseband generator. The three lower frequencies, 83.3, 250, and 500 kHz, are generated by direct division from a temperature-compensated master oscillator, followed by filtering. This LF generation section, shown shaded in Fig. 6, on its own forms the low-frequency 3715A plug-in. The high frequencies are generated by a crystal-controlled output oscillator with low phase noise, which is locked to the master oscillator via a variable divider and sampling phase detector. With suitable choice of loop bandwidth, the criteria of good stability, long and short term, are met.

The block diagram of the 3705A plug-in, which performs group delay and differential phase measurement, is shown in Fig. 7. As in the case of the 3716A, the 3705A is divided into two sections, one of which measures group delay at the three low frequencies while the other accommodates the high tones. The unshaded portion forms the 3703B plug-in which, with the addition of the shaded portion and a new front panel, becomes the 3705A.

The additional sections which make up the high-frequency version consist of a sampling type mixer and a crystal-controlled local oscillator and band-pass filter which convert all incoming high frequencies to a fixed 250 kHz frequency. The local oscillator has low phase noise since it also contributes to the trace noise.

The unshaded part of Fig. 7 measures group delay or differential phase. The basis of these measurements is a detector which compares the phase of the incoming test tone with a reference. Variations in this incoming phase, which occur at the sweep rate, are proportional to group delay.

The phase detector reference frequency must be locally generated since the baseband generator reference is not necessarily available. This is achieved with a stable 1-MHz reference oscillator that, suitably divided, is phase locked to the incoming frequency. The loop bandwidth is much less than the sweep frequency so the 1-MHz oscillator does not follow sweep-rate phase variations. Thus at the phase-sensitive detector output there is a signal proportional to the varying component of the incoming phase modulation. This then is the group delay or differential phase signal.

Also included in the 3703B/05A is a second phase detector, driven by a phase-shifted reference, which provides indication of both phase lock and level.

Acknowledgments

Owen Livingstone was responsible for the product design of the 3710A and Harry Elder for that of the 3702B. The 3702B electronic design was carried

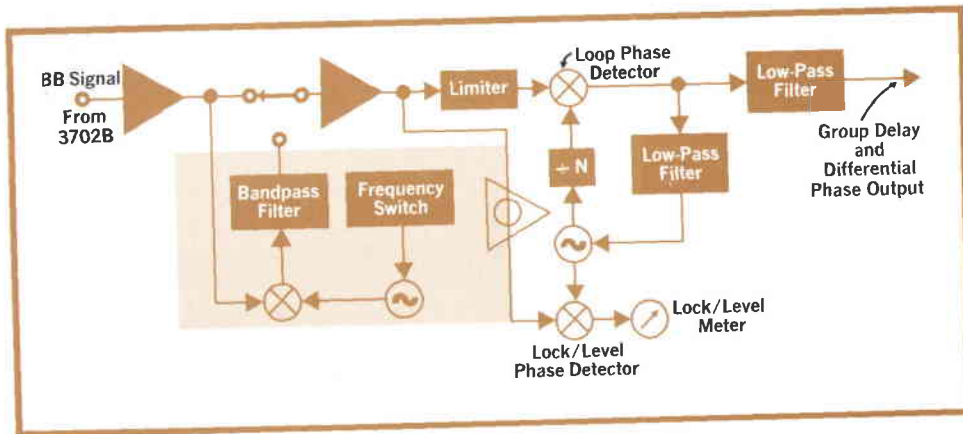

Fig. 7. Receiver plug-ins measure group delay and differential phase. 3703B (unshaded) is for low-frequency test tones. 3705A (entire diagram) accommodates high tones.

out by Colin Appleyard and Ian Matthews who also worked on the 3710A together with Hugh Walker. Alistair Sharp and Bryan Lewis worked on the

3710A plug-ins. Norman Edgar designed the 3703B and 3705A differential phase detector plug-ins while Duncan Reid did the product design.

ABRIDGED SPECIFICATIONS HP 3702B/3710A Microwave Link Analyzer

MEASUREMENTS:

- Group Delay/Differential Phase
- Linearity/Differential Gain
- IF Amplitude Response
- Sensitivity/Frequency Spectrum
- IF Return Loss/BB Return Loss
- Power/Gain/Attenuation

- 1 BB to BB Using internal BB frequencies
- 2 IF to BB 83.3 kHz to 8.2 MHz
- 3 BB to IF Using internal BB frequencies
- 4 IF to IF 83.3 kHz to 5.6 MHz†

†Above 5.6 MHz an external demodulator can be used.

SWEEP FREQUENCIES: 18 Hz, 70 Hz, Line, or EXT (10-100 Hz).

BASEBAND FREQUENCIES:

- With Plug-ins 3715A/3703B: 83.3, 250, 500 kHz.
- With Plug-ins 3716A/3705A: 83.3, 250, 500 kHz
- 2.4, 4.43, 5.6, 8.2 MHz.

EXT: 80 kHz to 10 MHz with demodulation to 5.6 MHz.

BASEBAND DEVIATION: 0.5 to 500 kHz rms.

SPECTRUM MODE: ±10 MHz centered on 70 MHz.

IMPEDANCES: 75 Ω

PRICE IN USA: \$10,500 to \$11,700 depending upon options selected.

MANUFACTURING DIVISION: HEWLETT-PACKARD LIMITED

South Queensferry
West Lothian
Scotland

Measurement	IF Range (MHz)	Maximum Inherent Slope		Maximum Inherent Noise (rms)		Range	Maximum Sensitivity
		BB-BB	IF-IF	BB-BB	IF-IF		
IF Response	45 to 95	—	±0.05 dB up to +5 dBm ±0.1 dB from +5 to +10 dBm	—	—	0 to ±3 dB via Y1 0 to ±3 dB via Y2	0.1 dB/cm
BB Linearity & Differential Gain	45 to 95	0.1%	0.4%	0.1%	0.1%	0 to 50%	0.25%/cm
	Bandwidth set at 1 kHz; BB of -10 to -49 dBm and sweep of 5 V pk-pk for BB-BB; for BB frequencies of 500 kHz and below, 200 kHz rms deviation for IF-IF; for BB frequencies above 500 kHz, 500 kHz rms deviation for IF-IF.						
Group Delay	55 to 85	0.1 ns	0.4 ns	0.1 ns	0.1 ns	200 ns	0.25 ns/cm
	45 to 95	0.1 ns	1 ns	0.1 ns	0.1 ns		
BB frequency at 500 kHz and bandwidth set at 1 kHz; BB of -20 dBm for BB-BB; 200 kHz rms deviation for IF-IF.							
Differential Phase	55 to 85	0.1°	0.4°	0.1°	0.1°	18°	0.5°/cm
	45 to 95	0.1°	0.6°	0.1°	0.1°		
BB frequency at 5.6 MHz and bandwidth set at 1 kHz; BB of -20 dBm for BB-BB; 500 kHz rms deviation for IF-IF.							
IF Return Loss	45 to 95		1 dB			10 to 49 dB	1 dB/cm
	Accuracy depends on balance of hybrid used.						

APPENDIX

Derivative and Differential Measurements

The graph here shows a plot of phase versus frequency for a network. The three arrows represent the spectrum of a carrier modulated by a single frequency; this is the input to the network. Either amplitude or frequency modulation can be considered if it is assumed that, in the case of frequency modulation, the index is sufficiently low to neglect second-order sidebands.

At the output of the network, this test signal will have been modified so that there is a phase difference $\Delta\phi$ between the sidebands. Since the modulating frequency is constant, $\Delta\omega$ is also constant. Therefore we can say that $\Delta\phi$ is proportional to $\frac{\Delta\phi}{\Delta\omega}$.

If $\Delta\omega$ is small, i.e., if the test tone frequency is low, then

$$\frac{\Delta\phi}{\Delta\omega} \approx \frac{d\phi}{d\omega} = \text{group delay}$$

Therefore if the phase variations of a low-frequency test tone are measured as the carrier is swept from, say, ω_1 to ω_2 , then these variations are proportional to the network group delay.

Now consider the effect of IF networks when they are preceded by a perfect modulator and followed by an equally perfect demodulator. With this configuration it is not generally realized that a linear network, for instance an IF filter, can cause nonlinearity in the baseband V_{in}/V_{out} characteristic. Amplitude non-flatness in the filter, by altering the relative levels of carrier and sidebands, can change the deviation of an FM signal, consequently changing the BB gain. It can be shown that when nonlinearity is measured between baseband points it is proportional to the second derivative of the IF amplitude response. This type of distortion is measured much as is group delay, except that in this case amplitude variations of the test tone at the sweep rate are detected.

These arguments indicate that as $\Delta\omega$ is reduced the accuracy of the derivative measurements is improved. It would also appear that, with a sufficiently accurate measure of linearity and group delay, predictions of the noise power ratio could be made. Unfortunately this has not turned out to be true in practice; there is a discrepancy between measurements done with low-frequency tones and white noise tests. A considerable amount of theoretical work has shown that the discrepancy is due to the fact that there are types of distortion, which are important noise contributors, whose effects in group delay are proportional to test-tone frequency and whose effects on linearity are proportional to the square of test-tone frequency. Tests using tones less than 1 MHz are not a sensitive enough measure of these distortions. The new HP MLA therefore has the capability of making measurements at both IF and baseband with a range of test tones up to and including 5.6 MHz and measurements from IF to BB or BB to BB with a test tone of 8.2 MHz.

When the test tone is greater than 1 MHz, group delay and linearity measurements are referred to as differential phase and differential gain since they are no longer good approximations to derivative measurements.

A further effect which is more easily detected with high-frequency test tones is known as amplitude modulation to phase modulation conversion—AM-to-PM conversion. This effect, usually associated with the limiters which remove incidental AM in an FM system, means that some of the incident AM is converted to PM at the output. This PM combines with the original FM and usually gives rise to distortion. Equations 1 and 2 describe the distortion effects and demonstrate the effect of test-tone frequency:

$$\text{Differential Gain at } \omega_c = 1 - \left[a''(\omega_c) - k\tau'(\omega_c) \right] \frac{\omega_m^2}{2} \quad (1)^*$$

$$\text{Differential Phase at } \omega_c = \left[\tau(\omega_c) + ka'(\omega_c) \right] \omega_m \quad (2)$$

where ω_c is carrier angular frequency, $a(\omega_c)$ is amplitude response, $\tau(\omega_c)$ is group delay response, ω_m is test-tone angular frequency, and k is AM-to-PM conversion coefficient.

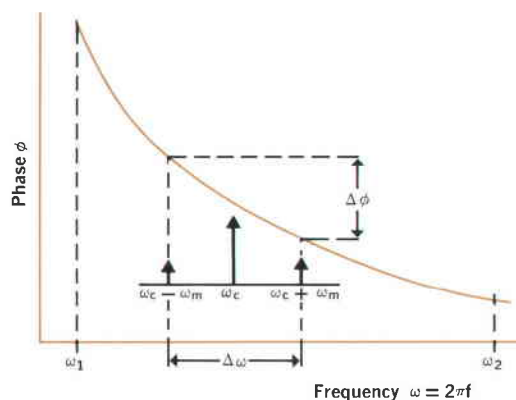

The new high-frequency test tone capability, together with a knowledge of equations 1 and 2, forms a powerful diagnostic tool. For instance, if a measurement shows differential gain then an examination of equation 1 shows that this can have two causes. The first term $a''(\omega_c)$ indicates that cubic or higher amplitude responses can give rise to differential gain, while the second term, $k\tau'(\omega_c)$, shows that quadratic or higher group delay responses followed by AM-to-PM conversion can also contribute. A group delay measurement will then fully determine the differential gain source.

*The HP Microwave Link Analyzer displays the variable part of this equation.

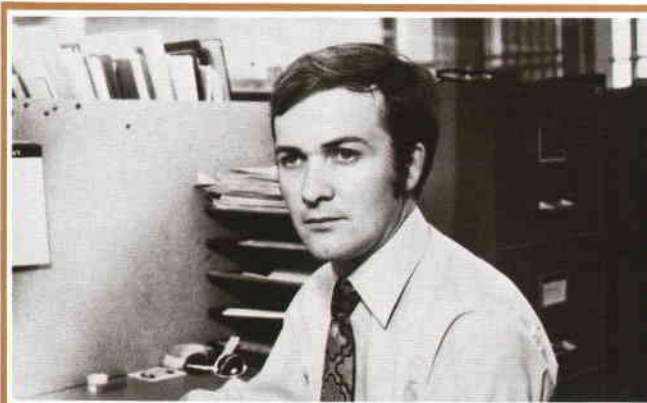

Reid Urquhart

After graduating with a B.Sc. degree in Electrical Engineering from Glasgow University in 1965, Reid Urquhart worked for two years in satellite communications before joining HP Ltd. at South Queensferry, Scotland. He took up project responsibility for the new MLA systems in 1969 and has worked on the project all the way through to production. Recently he has done some work towards an M.Sc. degree in digital techniques at Heriot-Watt University in Edinburgh. His favorite hobby is golf, but he suspects that his recent marriage and shortly to be acquired new home may well fully occupy his spare time.

MLA Measures RF Performance with Down Converter

Using this addition to the HP Microwave Link Analyzer gives new insights into microwave link performance.

By Michael Crabtree

UNTIL RECENTLY, DISTORTIONS HAVE BEEN MEASURED AND CORRECTED only in the IF and baseband sections of microwave links. This practice permitted signals with amplitude and phase distortion to be present in the microwave path. Devices that exhibit AM-to-PM conversion, such as mixers, TWT's and multipliers, introduce further distortions that conventional equalization does not correct.

The new Model 3730A Down Converter, Fig. 1, extends the MLA's measurement capability to the microwave sections of links and, in particular, for the first time it measures group delay and FM linearity distortions introduced by the transmitter.

The Down Converter consists mainly of a mixer and local oscillator. Microwave signals carrying sweep and test tone information are converted to 70 MHz, and this signal, still retaining the full information, is fed to the MLA. A prime objective in the design was to avoid degrading the signal in the

measurement channel during the conversion process. Several features contribute to this end.

The return loss (VSWR) of the items of equipment making up the measurement channel can significantly degrade group delay measurements due to reflections in the cables. To provide the best possible input return loss for the instrument, a 10 dB thin-film broadband attenuator is connected to the mixer input. This also has the effect of reducing unwanted output signals generated by the frequency conversion process. Although this attenuation degrades the instrument noise figure, it is not significant in most applications.

To avoid further group delay distortion, the instrument is broadband, both at RF and IF. The 1-12 GHz mixer is followed by one or two (option 010) IF amplifiers. This combination gives less than 1 ns residual group delay distortion which is further reduced by an equalizer, finally giving less than 0.5 ns in any 50 MHz band.



Fig. 1. Model 3730A Down Converter extends the Microwave Link Analyzer's capability to the microwave section of communications links.

A frequency control loop is provided to lock the center of the swept IF signal automatically to 70 MHz. The response of this AFC is only significant below 15 Hz and so, although eliminating small drifts and adjustments of the RF signals, it does not have significant tracking action above this frequency. Consequently, the marker accuracy of the MLA is retained when measuring the width of a swept RF band. The key component in the AFC circuit is the linear and stable pulse count discriminator used in the 3710A MLA transmitter. To assist initial tuning, an intermediate frequency meter is provided on the front panel; this is also driven from the discriminator.

To prevent overloading and consequent distortion in the IF stages of the converter, an excess level lamp is provided. This is driven from a broadband detector on the output of the IF.

To allow complete coverage of the microwave communication bands, plug-in local oscillators are used, calibrated to read the RF input frequency. The 3721A, 3732A and 3733A Plug-ins cover the 6 GHz bands. These contain cavity-tuned transistor oscillators followed by a varactor frequency multiplier and have very low phase noise. Other plug-ins are being developed for the 2, 4, and 11 GHz communication bands. They use the YIG-tuned transistor and Gunn oscillators developed for HP's microwave sweeper program. Phase noise is also low for these devices because of the YIG's characteristically high Q.

Applications

Applications of the Down Converter arise wherever microwave links are found. In production, completed transmitters can be aligned and specified individually and in isolation from the receiver.

In commissioning of systems, initial antenna alignment and checking of waveguide runs can be facilitated using the converter. Multihop equipment checks can be performed since the converter does not limit the remote measurement capability of the MLA.

Used for maintenance or repair, the down-converter can isolate faults to transmitter or receiver, eliminating interstation arguments about fault location.

With the introduction of RF repeaters with no IF sections, RF measurement will become essential for system checking. The ability to characterize a transmitter should mean that any transmitter can work with any receiver, thus reducing equipment redundancy for standby purposes.

When the Down Converter is used with a suitable

microwave generator (such as the 8605A described elsewhere in this issue), RF-RF group delay measurement becomes possible, allowing microwave components to be specified for their group delay performance. The generator acts as an up converter.

Acknowledgments

Thanks are due to Bryan Lewis and Don Reid for their contribution to the design, to Alan Bradley for the Product Design, and to Finlay Mackenzie for suggesting the original idea. 📄

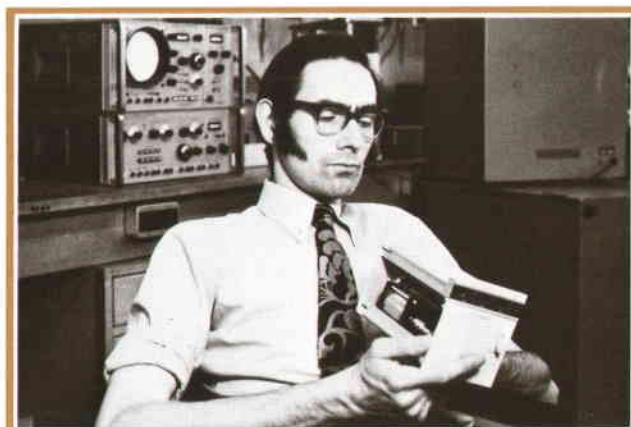

Michael Crabtree

Mike Crabtree completed an engineering apprenticeship with the British Post Office during which time he obtained his B.Sc. Degree. He followed this with a Ph.D. at Birmingham University and joined HP in 1967. His principal activity has been the project leadership of the 3730A Down Converter. Currently he is responsible for radio communication projects at HP Ltd. His interest outside his home and family is mainly sailing—Mike is vice commodore of HP Ltd's sailing club.

SPECIFICATIONS

HP 3730A Down Converter (when used with MLA)

GROUP DELAY RESPONSE:

Resolution: 0.1 ns using 500 kHz test tone
Residual: < 1 ns over any 50 MHz band
Range: 200 ns

AMPLITUDE RESPONSE:

Resolution: 0.025 dB
Residual: < 0.5 dB over any 50 MHz band
Range: Calibrated to 3 dB

RF INPUT FREQUENCY:

Determined by oscillator plug-in
3731A: 5.925 to 6.525 GHz
3732A: 6.420 to 6.920 GHz
3733A: 6.870 to 7.270 GHz

FREQUENCY STABILITY: ±0.05%

PRICE IN USA: \$4270 with one plug-in.

MANUFACTURING DIVISION: HEWLETT-PACKARD LIMITED
South Queensferry
West Lothian
Scotland

Communications-Oriented Microwave Solid-State Sweeper

One use is as an up-converter with the HP Microwave Link Analyzer to make RF measurements.

By Arlen E. Dethlefsen

HIGH-CAPACITY MICROWAVE LINKS require extremely flat IF (47-100 MHz) and RF (3.6-11.7 GHz) swept measurements to assure proper alignment of the radio repeaters. In the past, swept measurements were accomplished by using separate IF and RF sweepers dedicated to a particular radio system. Another alternative was to use a sweeper with multiple plug-ins. These methods are expensive and not altogether convenient for present-day microwave communication links, which quite often use radio channels in more than one of the common carrier bands.

To meet the needs of present-day microwave links an all solid-state sweep oscillator, Model 8605A, accommodates up to three microwave communication bands and an IF swept source in a single instrument. The RF and IF controls are entirely independent to minimize adjustments when the user is alternating between RF and IF measurements.

IF Features

The IF sweeper section of the 8605A is tunable from 47 to 100 MHz in either the CW or ΔF (symmetric sweep) mode. Maximum ΔF width is 53 MHz. Both center frequency and sweep width are calibrated. Drift is low (< 50 kHz per 15 min), and leveling is good (± 0.005 dB from 55 to 85 MHz).

The IF sweep circuitry consists of a 200-MHz crystal-controlled oscillator and a 247-to-300 MHz varactor-tuned oscillator. The outputs of these oscillators are mixed, then the 47-100 MHz signal is filtered and amplified to provide the desired output signal.

The voltage-tuned oscillator tunes with about 1% linearity, and is temperature-compensated to reduce frequency drift. Spurious mixing products are typ-

ically 70 dB down, and harmonics are typically 50 dB down, at an output of +12 dBm. Flatness is typically ± 0.02 dB across the entire 47-to-100 MHz band, measured at the end of 10 feet of cable. A "slope" control is provided on the front panel to increase the output power as a function of frequency. This allows the IF swept signal to be adjusted so as to be flat at the input of the device being tested.

RF Features

The RF portion of the 8605A consists of up to three bands in the range 1.7 to 13.25 GHz, selected from a maximum of two YIG-tuned fundamental oscillators. For example, three widely-used common carrier bands (3.65-4.25, 5.9-6.5 and 10.7-11.7) can be covered by HP's 3.2-6.5 and 8-12.4 GHz oscillators.

A specially designed temperature compensation circuit is used to reduce warm-up drift and improve

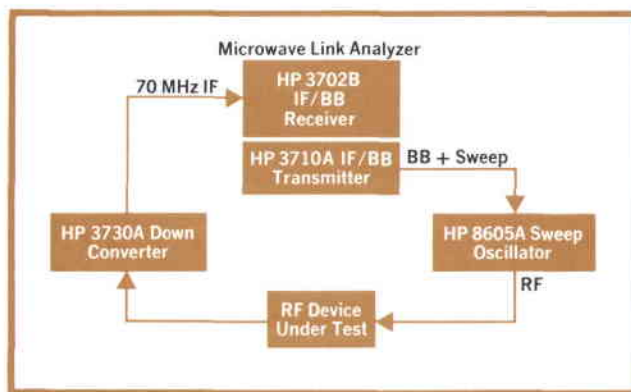

Fig. 1. RF-to-RF group delay measurement using 8605A Communications Sweep Oscillator with Microwave Link Analyzer and Down Converter.

frequency accuracy and stability. After a 15-minute warm-up period, frequency drift will typically be less than $\pm 0.015\%$. Frequency accuracy is typically better than 0.1%.

Very flat RF power leveling (typically ± 0.01 dB over any 30-MHz communications channel) is achieved by using HP's 784A 1.7-12.4 GHz directional detector. This very flat leveling capability has been achieved by optimizing the source match of the instrument, the directivity and flatness of the coupler, and by reducing harmonics and spurious signals. Maximum leveled power output is greater than +13 dBm at the lower frequencies and greater than +10 dBm at the higher frequencies.

Spurious harmonics are more than 40 dB down from the fundamental at all frequencies. Nonharmonic spurious signals are more than 60 dB down.

Frequency Modulation Capability

The 8605A can be equipped with an FM option (option 070) that is especially designed to interface with HP Microwave Link Analyzers. In this mode the 8605A is used as a baseband-to-RF up converter. Group delay and flatness measurements can be made from RF to baseband or RF to IF. With the addition of the HP 3730A Down Converter, a complete RF-IF-Baseband measurement is possible. A block diagram of a typical RF-to-RF delay distortion measurement is shown in Figure 1.

Acknowledgments

Bob Bathiany was responsible for the design of all the mainframe circuits, including the YIG oscillator drivers. Steve Sparks had responsibility for the IF sweep generator section. Dick Barg did the product design for the entire instrument. Phil Chen and Dick Bingham were instrumental in the success of the project through their work on the microelectronics in the power amplifier. 

SPECIFICATIONS

HP Model 8605A Communications Sweep Oscillator

See article for basic specifications. Complete data available on request.

PRICE IN USA: \$3875 to \$7000, depending on options.

MANUFACTURING DIVISION, MICROWAVE DIVISION
1501 Page Mill Road
Palo Alto, California 94304



Arlen E. Dethlefsen

Arlen Dethlefsen holds two B.S. degrees from California Polytechnic Institute, one in mathematics and the other in electrical engineering. He received both in 1961. His M.S.E.E. degree was earned at Northeastern University in 1963. Arlen joined HP in 1968 after five years of development work on microwave radio systems. His two most recent instruments are the 86320A Heterodyne Converter for the 8620 Oscillator family, and the 8605A Communications Sweep Oscillator. He was project supervisor for both. He's now microelectronics production engineering manager. Among his nonelectronic interests, Arlen puts skiing and tennis at the top of his list.

HEWLETT-PACKARD JOURNAL
SEPTEMBER 1972 Volume 24 • Number 1



Technical Information from the Laboratories of
Hewlett-Packard Company, 1501 Page Mill Road,
Palo Alto, California 94304 U.S.A.
Hewlett-Packard S.A., 1217 Meyrin—Geneva, Switzerland
Yokogawa-Hewlett-Packard Ltd., Shibuya-Ku, Tokyo 151 Japan

Editorial Director: Howard L. Roberts
Managing Editor: Richard P. Dolan
Contributing Editors: Ross H. Snyder, Laurence D. Shergalis
Art Director, Photographer: Arvid A. Danielson
Art Assistant: Erica R. Helstrom
Administrative Services: Ruth G. Ross

HP Archive

This vintage Hewlett-Packard document was
preserved and distributed by

www.hparchive.com

Please visit us on the web!

On-line curator: John Miles, KE5FX

jmiles@pop.net

