

APRIL 1972

HEWLETT-PACKARD JOURNAL

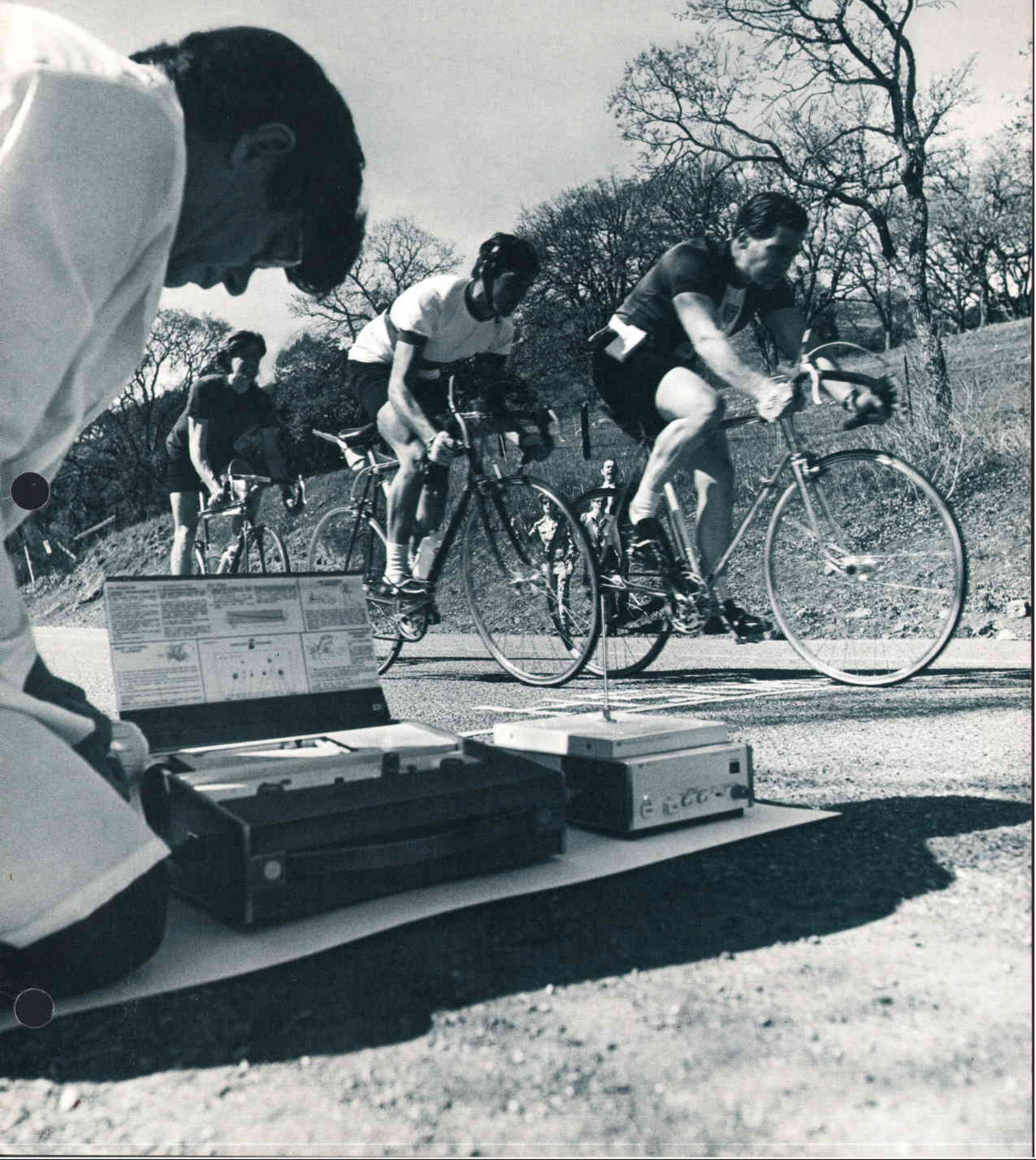

An Effective ECG Telemetry System

Replacing direct wiring with an RF telemetry link benefits a monitored cardiac patient by releasing him from the confines of a bed, but it could create some additional problems for the nursing staff. The ECG Telemetry System described here deftly overcomes these problems.

By James L. Larsen, Richard F. Dillman, Alfred M. Nardizzi, and Richard N. Tverdoch

THE BASIC ELECTRICAL FUNCTIONS performed by patient-monitoring instruments — e.g., ac amplification, pulse rate measurement, and so on,—are simple enough in concept but the realization of instruments that perform these functions reliably is far from simple. Designing instruments that do what hospital personnel expect, and do it without a lot of expert attention, requires considerable attention to detail on the part of the designer.

These problems are compounded when designing an RF telemetry link for a patient-monitoring system. Here the designer must cope with additional problems, such as those caused by the patient's movements, by widely varying signal strength, and by interference from electrical equipment and other radio systems. At the same time, the designers cannot expect the nursing staff to function as electronic technicians by making complicated tuning adjustments.

With this in mind, a new ECG Telemetry System has been designed (Fig. 1), one that is not an outgrowth of programs directed towards other objectives, but one that was designed from the outset to be used in the hospital environment.

Wireless relay

The new Telemetry System replaces the wiring between patient electrodes and monitoring instruments in an intermediate coronary care unit, giving the patient freedom to move about while the performance of his heart is being monitored. The primary requirement is for the system to supply an ECG waveform to the monitoring instruments exactly as if the instruments were connected directly to the patient. A monitoring system that uses the telemetry link can thus provide all the functions of heart-rate monitoring, ECG waveform display, ECG waveform recording, and arrhythmia analysis that a hard-wired coronary-care system would provide.

The patient carries a small, battery-powered Transmitter (Hewlett-Packard Model 78100A) that transmits the ECG waveform on low-power Business Radio frequencies in the 450–470 MHz band. Operation in the Business Radio Service, in addition to providing the protection of licensing, allows sufficient transmitted power to adequately cover large areas of a hospital. Radiation at 450–470 MHz is well suited for transmission within a hospital, and this band has the added advantage of having a large numbers of channels available.



Cover: *Measuring the heart rate of a racing bicyclist under full steam was not what the designers had in mind when developing HP's new ECG Telemetry System, but it does demonstrate uses for this system outside the cardiac care unit. For a description of how the ECG Telemetry System works in*

its intended environment, see the article beginning on this page.

Our thanks to the 1972 U.S. Olympic Cycling Committee for allowing Arvid Danielson (a team representative) to appear on our cover.

In this Issue:

An Effective ECG Telemetry System, by James L. Larsen, Richard F. Dillman, Alfred M. Nardizzi, and Richard N. Tverdoch. **page 2**

A Human Interface for Automatic Measurement Systems, by Kenneth A. Fox, Marc P. Pasturel, and Peter S. Showman. **page 10**

An Agile Graphic Display Device by John Rikken and Douglas Fogg. . . **page 18**

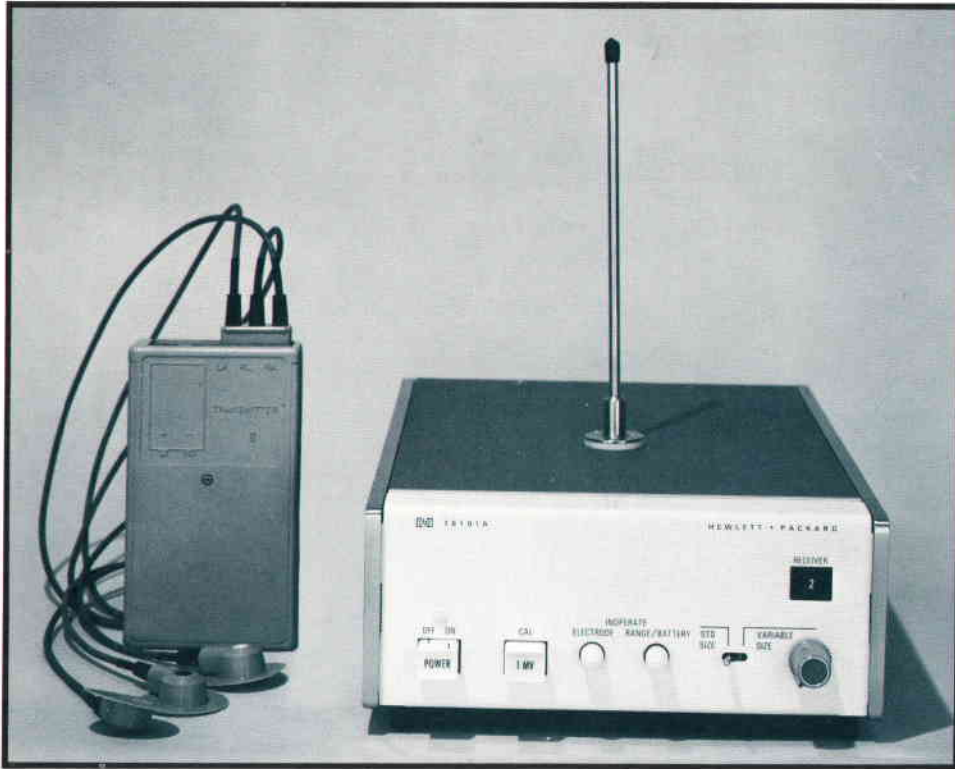

Fig. 1. Model 78100A ECG Telemetry Transmitter (left) and Model 78101A Receiver substitute an RF link for direct wiring between cardiac patient and monitoring instruments.

Modulation is FM/FM, the ECG waveform frequency modulating a subcarrier that in turn frequency modulates the RF carrier. This isolates the ECG from frequency drifts in the carrier, contributing to a stable baseline. A stable baseline is important because baseline instability increases the

incidence of false alarms from the monitors, and also makes it more difficult for a nurse to watch the ECG waveforms on an oscilloscope.

The Receiver (Model 78101A) is connected to the monitoring instruments at the nurses' station or at bedside. Both Transmitter and Receiver are crystal

Why ECG Telemetry?

ECG telemetry promises further reductions in the mortality rates for hospitalized coronary patients.

A substantial reduction has already resulted from the establishment of instrumented Coronary Care Units (CCU). During the high-risk period immediately following a heart attack, the coronary patient is confined to bed in a CCU and monitored continuously by hard-wire connections direct to monitoring instruments. The use of these instruments for continuous observation of the patient's physiological condition, along with intensive nursing care, enables timely detection, prevention, and treatment of life-threatening cardiac events.

When the patient's condition has stabilized, usually within four or five days, he is disconnected from the CCU instruments and moved to a general care ward, away from the trained coronary nursing staff. During this second stage of recuperation, the patient begins to take care of his own needs and he becomes ambulatory for longer and longer periods of time. If by chance his heart is not sufficiently recovered from the first attack, the increased activity and exertion could trigger a second attack.

The need to monitor these patients during the early stages of increased activity is leading to establishment of

Intermediate Coronary Care Units (ICCU). In the ICCU a trained nursing staff is available, though on a less intensive basis, and the patient is free to move about. His electrocardiogram (ECG), however, is monitored continuously by telemetry. This use of telemetry provides a less costly, intermediate stage of care that smooths the patient's transition back to a normal life.

Additional benefits

A telemetry system provides several other advantages for coronary care, in addition to allowing a monitored patient the freedom to move about. For one, by eliminating the need for wiring between bedside monitors and a central station, it simplifies installation of CCU's in existing hospitals. It also allows any bed to be a monitored bed, lessening the constraints on bed assignments. It permits casual surveillance of suspected coronaries without the unnatural constraints of confining the patient to bed.

In addition, telemetry provides a convenient method for monitoring ECG's in the operating room without adding to the clutter of wires around the patient, and it can be used to monitor patients during exercise tolerance tests, allowing a physician to study the heart's response to exercise without encumbering the patient with long trailing wires.



Fig. 2. Telemetry Receiver conforms to modular design of HP patient-monitoring instruments. Modular approach makes it possible to configure monitoring systems using the telemetry link to meet the particular requirements of any hospital.

controlled so no tuning is required on the part of hospital personnel. To place the system into operation, all that is required is to attach the electrodes to the patient, insert the battery into the Transmitter, plug in the electrode cable, and turn on the Receiver (the Transmitter has no power switch so that it can't be turned off inadvertently).

Besides being easy to operate, a hospital system such as this should guard against potential malfunctions and give assurance that everything is working properly. Accordingly, the Receiver has 'inoperative' indicator lights that alert the staff to the most common system malfunctions: an electrode has fallen off, the patient has gone out of range, or the transmitter battery has run down. With any of these conditions, the ECG output is automatically grounded, so an erroneous ECG is not produced, and an 'inhibit' signal is sent to the monitoring instruments so no false alarms will be sounded. The use of 'inoperative' indicators simplifies interpretation of system performance for the nurse, and it further eliminates false alarms as a source of confusion.

The system fits effectively into emergency resuscitation procedures. The Transmitter is protected against the large potentials generated during defibrillation. In addition, it uses the same electrode set as the standard HP hard-wired systems so that a quick changeover to direct monitoring is effected simply by unplugging the electrode connector from the Transmitter and plugging it into a patient cable connected to the ECG monitor on the hospital's resuscitation cart. Thus there is no need for a special channel-switching RF receiver on the cart to enable the resuscitation crew to see the ECG waveform.

The system also reduces significantly ECG waveform distortions caused by pacemaker pulses, should the patient be using a pacemaker. Pacemaker pulses, as picked up by the ECG electrodes, can be as large as 80 mV, compared to the 1-2 mV typical of the ECG. The new ECG Transmitter's amplifiers are slew-rate limited so that these relatively narrow pulses are reduced in amplitude substantially.

The new ECG Telemetry System is fully compatible electrically and physically with the HP 780-series patient monitoring instruments, so it can be added to existing systems as well as be supplied as part of new systems. It can be combined with various patient monitoring instruments to provide a flexible ambulatory patient monitoring system that can be configured to meet the particular requirements of any hospital (Fig. 2). By operating several telemetry links on different carrier frequencies, the monitoring system can be configured to accommodate any number of ambulatory patients.

The details

A block diagram of the ECG Transmitter is shown in Fig. 3. The transmitter picks up the ECG through three fluid-column electrodes attached to the patient's chest. The ECG waveform frequency-modulates a 1-kHz subcarrier that in turn frequency-modulates the UHF carrier. The resulting signal is radiated by one of the electrode leads serving as the antenna.

At the input, a differential emitter follower provides an impedance of more than 10 megohms for the ECG electrodes. A diode network limits the large amplitude pulses that may result during defibrillation.

The output of the ECG input amplifier is ac-coupled to succeeding circuits, eliminating any dc voltage that may result from contact potentials at the patient-electrode interface. This capacitor de-

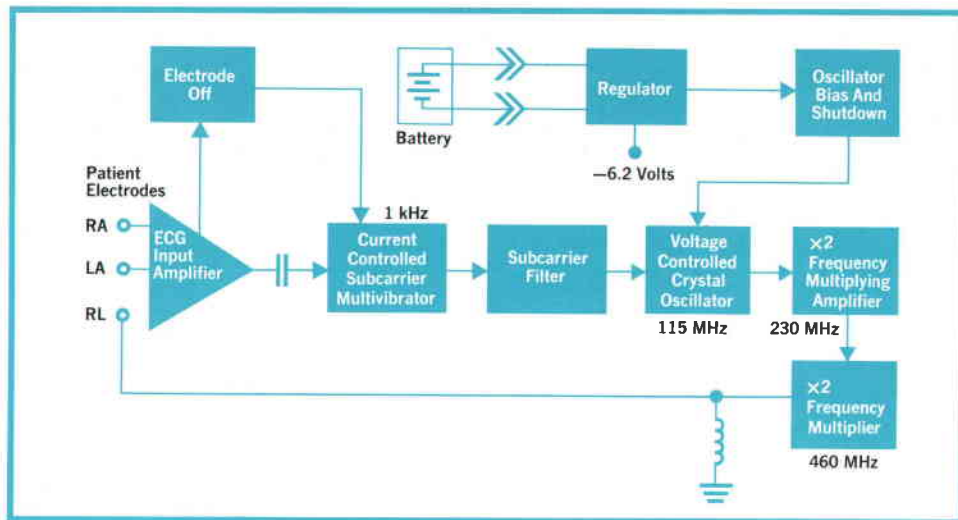

Fig. 3. Block diagram of ECG Telemetry Transmitter.

termines the low-frequency cut-off of the system and is chosen to place the 3-dB point at 0.4 Hz in the standard transmitter. As an option, this can be changed to 0.05 Hz for those cardiologists who prefer to work with the 'diagnostic' bandwidth.

The subcarrier oscillator is a current-controlled multivibrator. For a full-range $\pm 5\text{mV}$ ECG the frequency deviation is ± 320 Hz from the 1-kHz center frequency. The subcarrier oscillator is followed by an active filter that removes the square-wave harmonics, leaving a sinusoid for modulating the RF carrier.

When a patient electrode falls off, the input amplifier loses bias because the bias networks are completed through the patient's skin resistance. This condition is sensed by a network that responds by shifting the frequency of the multivibrator to about 400 Hz. Frequency-sensitive circuits in the receiver detect this condition and turn on the ELECTRODE INOPERATIVE alarm.

All the circuits to this point were designed to use a minimum of supply current so as to subtract as little as possible from that available for RF output. Total current drain of all the low-frequency circuits is only $300 \mu\text{A}$.

UHF carrier generation

The carrier generating train consists of a grounded-base crystal oscillator and two frequency-doubler stages. The oscillator crystal is a fifth overtone device operating at about 115 MHz in the series-resonant mode. It is connected into the oscillator feedback loop in series with a trimmer capacitor for center frequency adjustment and a varactor diode that provides a means for frequency modulation.

A tight temperature specification on the crystal

together with temperature compensation provided by a capacitor in the tank circuit keep the oscillator frequency within $\pm 6\text{ppm}$ over a temperature range of $0\text{--}55^\circ\text{C}$. A shunt load in the oscillator collector plus the buffering provided by the multiplier stages minimizes the frequency variations that might result from the large changes in antenna impedance caused by patient movement.

The first doubler stage is a class-C transistor doubler and the second is a series-connected step-recovery diode doubler. These are designed for maximum efficiency at low power levels.

Output power is around 2 mW, optimizing the trade-off between transmitter power and battery life. Transmission ranges within a hospital are variable depending on the type of hospital construction, but for this system an operating range on the order of 200 feet is common. The battery is a standard 8.4-volt mercury cell with an operating life of 3 to 5 days in this system.

The transmitter output is connected to the common (RL) patient electrode lead. This lead serves as the antenna, a convenient arrangement for the patient as it eliminates the need for a separate antenna. The Transmitter accommodates the impedance distortion that the patient's movements would cause in this or any other type of body-worn antenna.

A series regulator in the Transmitter drops the battery voltage to the 6.2 volts required by the circuits. As the battery nears the end of its useful life, the regulator senses the drop in battery voltage and turns off the supply to the oscillator so the oscillator will not drift off channel. At the same time, the regulator switches in a compensating load to keep the battery from recovering, thus eliminating the possibility of a slow relaxation oscillation as the battery recovers, runs down again, and so on.

The Importance of Slew-Rate Limiting

The hearts of many coronary patients are assisted by electrical pacemakers that stimulate the contraction of the heart. The pace pulses generated by these instruments, when picked up by the electrodes of an ECG monitoring system, can be on the order of 80 mV in amplitude. This compares with the 1–2 mV amplitude of a typical ECG, as shown in Fig. a.

Because the pace pulse is many times greater than the ECG peak amplitude, the ECG waveform can be distorted significantly by the overshoot of the pulse's trailing edge,

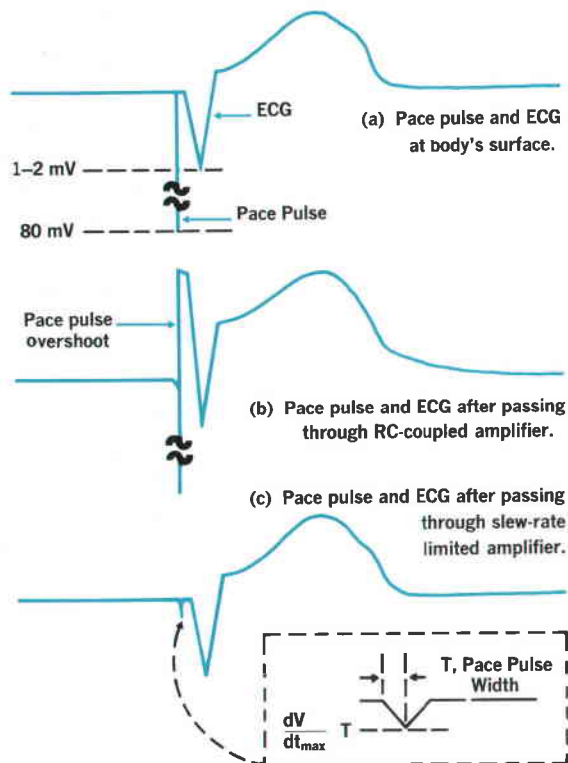

as shown in Fig. b, a result of the high-pass RC-coupling network. This distortion can present a confusing display to the nurse or cardiologist. In addition, the distortion may blank significant parts of the ECG waveform, or it may be wrongly interpreted as being of physiological origin.

Fortunately, pace pulses, usually 2-ms wide, are many times narrower than the QRS complex of the ECG. Thus, by limiting the slew rate of the ECG amplifier, the pace pulse can be reduced substantially before being passed through an RC-coupling network. In the Model 78100A ECG Telemetry Transmitter, the slew rate limit is 0.25 mV/ms, referred to the input, which reduces an 80-mV/2-ms pace pulse to 0.5 mV, leaving an undistorted ECG waveform.

The circuit for slew-rate limiting is shown below. Because amplifier U1B is connected as an integrator, its output is equal to the output of U1A divided by RC. The output of U1A is constrained by the power supply, so the slew-rate of the U1B output is limited. Feedback through R_f sets the gain for non-limited signals.

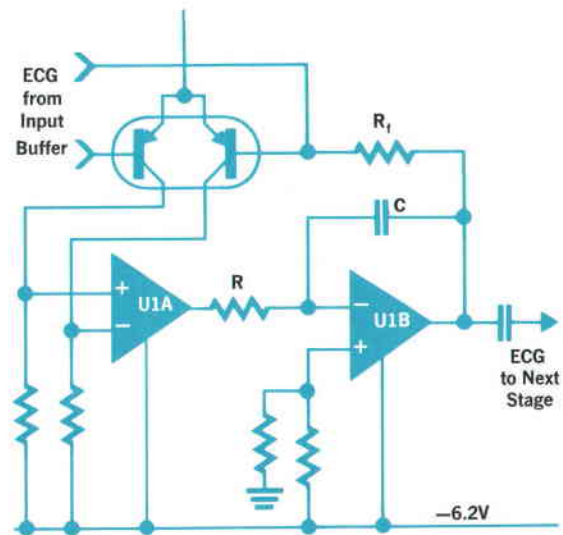

The transmitter circuits are on a printed-circuit board mounted in a drawn metal can covered first with a tuning cover, that fixes stray capacitance but that has holes to permit final tuning, and then with a sealing cover for protection against humidity. The transmitter package is molded out of durable glass-filled polypropylene which, unlike most plastics, is unaffected by any of the cleaning solvents commonly used in hospitals (alcohol, acetone, etc.).

At the nurse's station

A block diagram of the high-frequency section of the Receiver is shown in Fig. 4. This is a super-

heterodyne receiver with RF and IF circuits similar in concept to conventional designs.

The omnidirectional receiving antenna is a quarter-wave monopole mounted vertically over the ground plane of the receiver top cover, an arrangement that works well in the hospital and that is well-suited for picking up the randomly-polarized signals created by moving patients. Where Receivers are to be stacked upon one another, or where it may be desirable to place the antenna in a different location than the Receiver, a quarter-wave monopole mounted on an 8×10 inch ground plane is available for installation high up on a wall or hanging down from the ceiling.

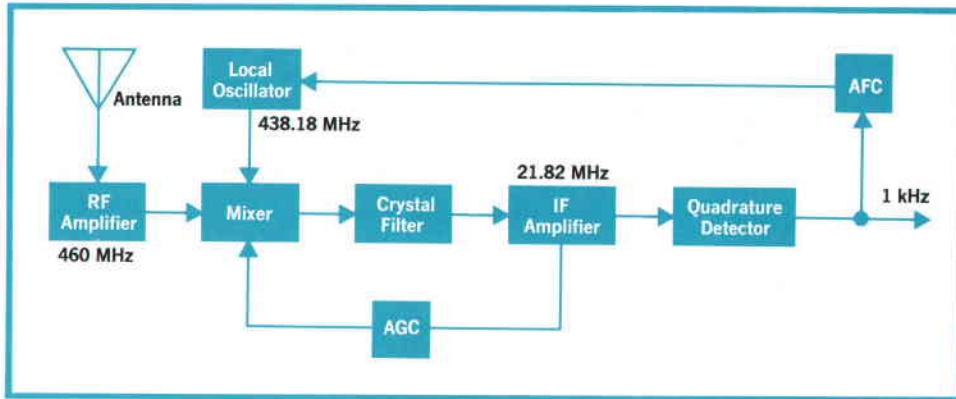

Fig. 4. Block diagram of high-frequency section of ECG Telemetry Receiver.

Inside the receiver

The RF amplifier consists of two bipolar transistor stages and two sharply tuned resonators. It performs the usual functions of providing a low noise figure, RF filtering, and image-frequency rejection. In addition, the RF amplifier, along with electrical shielding, suppresses local oscillator radiation to -60 dBm, a level far below that allowed by the FCC and far below that radiated from most conventional receivers. This minimizes the possibility of cross-coupling where several Receivers are used in one central station.

The local oscillator uses a crystal similar to the one in the Transmitter but, since power economy is not the prime objective here, it uses a transistor $\times 4$ multiplier and a tuned amplifier rather than two doubler stages. The mixer uses the square-law characteristics of a FET to minimize third-order

intermodulation products for avoiding interference problems.

Following the mixer is an 8-pole crystal filter that determines the receiver selectivity. This filter has a 10-kHz bandwidth and it provides 60-dB of rejection for signals 13 kHz from the IF center frequency (21.82 MHz). It permits several Receivers to work effectively in the same area with channel spacings of only 25 kHz.

The IF amplifier uses IC's for all five of its gain stages. The signal is tapped off following the second stage for the AGC amplifier. The AGC amplifier supplies the mixer bias network with a dc proportional to the IF signal level, and reduces the mixer gain under strong signal conditions so that the first two IF stages will not be overloaded.

The final three IF stages are limiting amplifiers so for normal operating conditions, the signal at the

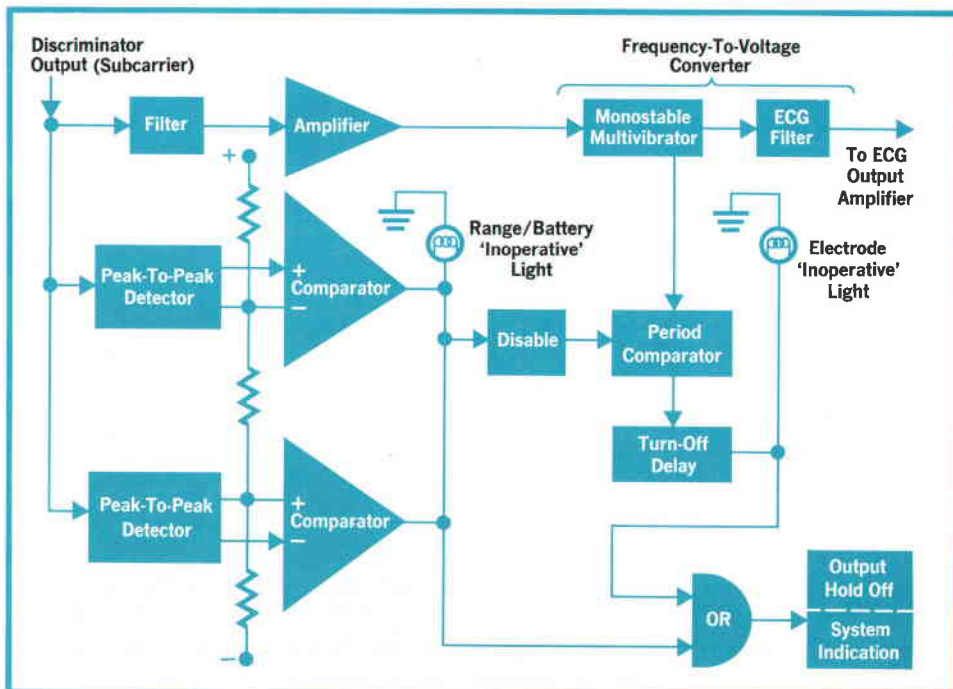

Fig. 5. Block diagram of ECG demodulation and 'inoperative' circuits in Telemetry Receiver.

output of the IF amplifier chain is held at a constant level.

The IF signal drives the discriminator, a quadrature detector. The resolution needed for demodulation at 21.82 MHz is obtained by using a crystal as the tuned element in the detector.

The many uses for a subcarrier

The output of the discriminator is the 1-kHz subcarrier. This output is averaged and fed back to the local oscillator for automatic frequency control, maintaining the dc level in the center of the discriminator response curve. Diode limiters acting on the feedback voltage constrain the range of AFC control to about ± 8 kHz, a range wide enough to compensate for drifts in the transmitter and local oscillator frequencies but not wide enough to permit the system to lock onto an adjacent channel signal.

In the absence of an adequate received signal, a low-frequency multivibrator is activated. Its output is added to the AFC feedback signal. Each time the multivibrator switches, it drives the local oscillator to one or the other side of its range and then returns it to the control of the feedback loop. This enables the receiver to find and lock on to a weak signal even though a strong interfering signal may be at one of the band edges.

The 1-kHz subcarrier also goes to several other circuits, as shown in Fig. 5. In the demodulation chain, it goes to a frequency-to-voltage converter that recovers the original ECG waveform. The ECG then goes through a low-pass filter to the output amplifier and thence to the monitoring instruments. The filter normally has a cut-off frequency of 50 Hz but this can be switched internally to 100 Hz

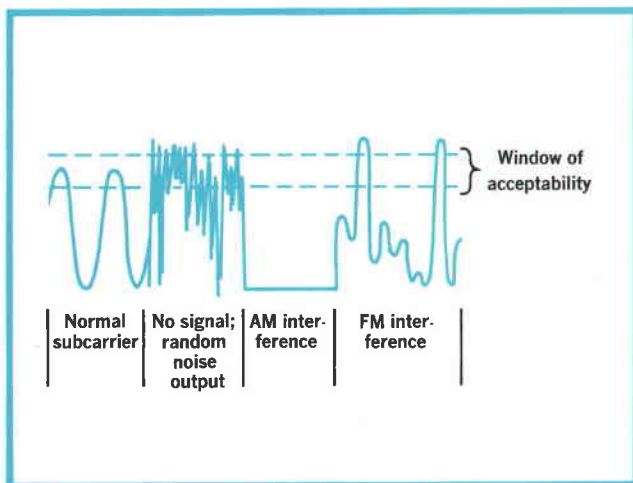

Fig. 6. Output of discriminator resulting from various receiving conditions.

for those who prefer working with the diagnostic bandwidth.

The 'inoperative' detection circuits examine the 1-kHz subcarrier to determine whether or not a satisfactory signal is being received. A 'window' of acceptability for the subcarrier amplitude is established by two comparators driven by detection circuits that respond to the peak-to-peak discriminator output level (Fig. 6). If the subcarrier amplitude is within the window, the received signal is considered valid.

What happens if the received signal is not valid? In the absence of a signal the discriminator output is random noise with peaks significantly higher than the window. If there is AM interference, the discriminator output is essentially a dc voltage that lies below the window. If there is FM interference or intermodulation between channels, the discriminator output is a complex waveform that is not likely to sustain itself within the window. When any of these conditions exist, the RANGE/BATTERY INOPERATIVE light is turned on and the output hold-off and alarm inhibit functions are initiated.

The ELECTRODE INOPERATIVE is triggered when the subcarrier frequency drops below 500 Hz. Pulses derived from the subcarrier discharge a capacitor that is allowed to charge between pulses. If the time interval between pulses becomes long enough to let the average capacitor voltage rise above a pre-set level—as would be the case with subcarrier frequencies below 500 Hz—then the ELECTRODE INOPERATIVE light is turned on and the output hold-off and alarm inhibit signals are activated. The same might happen with certain types of interference, of course, but the RANGE/BATTERY INOPERATIVE disables the ELECTRODE INOPERATIVE so only one or the other of these lights will be turned on at a time.

These 'inoperative' indicators simplify interpretation of system performance for the nurse, alerting her to possible malfunctions.

Acknowledgments

Dick Warmington contributed significantly to the project's definition. Bill Baskin and Joe Brown helped ease the transition into production. Bob McHenry is handling the product support. Tim Blancke, Bill Craven, and Jim Kistler have provided guidance over the years. Many others have contributed aid, advice, and support and to all we offer our thanks.

We would also like to acknowledge the contribution of the many hospitals who conducted on-site evaluation of the system. 

SPECIFICATIONS

HP Model 78100A/78101A ECG-Telemetry System

ECG CHANNEL

DIFFERENTIAL INPUT: Defibrillator-protected.

Input impedance: >10 megohms below 60 Hz.

Input range: ± 5 millivolts.

PACE PULSE REJECTION: Slow-rate limited to nominal 0.25 mV/ms, referred to input, to attenuate pace pulse (except Option 021).

ECG AMPLIFICATION: Internally switched to gain of 1000, 50 or 1. Gain stability is $\pm 7\%$, and gain accuracy at 25°C is 5%.

For control of display size, receiver can be switched at front panel from fixed to variable gain. Variable gain gives amplification of 20% to 400% of switch setting.

ECG FREQUENCY RESPONSE: 0.4–50 Hz (-3 dB points).

NOISE AT ECG OUTPUT: 10 μ V rms maximum (80 μ V p-p), referred to input, with each ECG lead connected to same point through 25K shielded resistor for a received RF signal $>10^{-13}$ W.

CALIBRATION VOLTAGE: 1 mV, referred to input, added to ECG output by pressing front-panel pushbutton. Accuracy at 25°C: 6% referred to Input.

ECG OUTPUT: Compatible with HP heart rate meters, scopes, recorders and arrhythmia monitor. Also compatible with most manufacturers' ECG monitors and displays.

OUTPUT IMPEDANCE: Less than 55 ohms.

ELECTRODE INOPERATIVE INDICATION: Receiver front-panel light for detached electrode.

RANGE/BATTERY INOPERATIVE INDICATION: Receiver front-panel light for low battery voltage, patient out of range, or excess radio interference.

CHANNEL INOPERATIVE SYSTEM SIGNAL: Occurs with inoperative conditions, and ECG output is grounded.

TRANSMITTER, MODEL 78100A

RF POWER OUTPUT: 2 mW into 50 Ω load (± 0.75 mW) measured from RL electrode connector to ground plane under transmitter.

CARRIER FREQUENCY: Determined by crystal.

FREQUENCY RANGE: Carrier 450 to 470 MHz.

FREQUENCY STABILITY: $\pm 0.0006\%$.

MODULATION TYPE: FM/FM.

BATTERY POWER: One disposable, 9-volt mercury cell (Mallory TR146X or equivalent).

PHYSICAL CHARACTERISTICS: Case, glass-filled polypropylene, 12.7 \times 7.4 \times 2.4 cm (5.0 \times 2.9 \times 0.95 in). Weight, 267 grams (9.5 oz.) including battery. Operating temperature, 0–55°C (32–131°F).

RECEIVER, MODEL 78101A

ANTENNA: Vertical, 7-inch monopole on top cover. External antenna optional.

RADIO-FREQUENCY INPUT IMPEDANCE: 50 Ω nominal.

FREQUENCY TUNING: Crystal-controlled.

OUTPUTS: One ECG telephone jack on rear panel, and two connectors that match Hewlett-Packard monitor system cabling.

POWER REQUIREMENTS: Receiver, 115/230 Vac $\pm 10\%$, 48–66 Hz, 35 VA max.

AUXILIARY POWER OUTLET: Unswitched IEC female receptacle provides up to 725 VA for auxiliary equipment.

PHYSICAL CHARACTERISTICS: Case, 8.9 cm high, 20 cm wide \times 27.9 cm deep (3.5 \times 7.89 \times 11 in). Channel number plate.

WEIGHT: 2.7 kg (6 lb).

OPERATING TEMPERATURE: 0–55°C (32–131°F).

OPTIONS

Option 021: Provides diagnostic bandwidth of 0.5 Hz to 100 Hz instead of standard bandwidth

Remote antenna and receiver packaging options are available for special mounting arrangements.

ACCESSORIES SUPPLIED

Redux electrolyte Creme, 5 oz.

8.4-volt battery.

Pouch and belt.

Electrode adhesive discs.

Electrode and cable set.

Operating manual.

Operating instruction card.

PRICE IN U.S.A.

Telemetry Channel consisting of 78100A Transmitter and 78101A Receiver \$1800.00.

MANUFACTURING DIVISION: MEDICAL ELECTRONICS DIVISION
175 Wyman Street
Waltham, Massachusetts 02154



(Authors from left to right)

James L. Larsen

Jim Larsen came east from Seattle to earn his BSEE and MSEE degrees from MIT following which he joined Hewlett-Packard's Medical Electronics Division in 1966. Before becoming project leader for medical telemetry, he was involved in an ultrasonic flaw detector project.

Jim is married, has two children, and favors sports and arts as spare time activities. Skiing, rugby, skin diving and family outings command the majority of his excess hours.

Richard Dillman

Richard Dillman came to Hewlett-Packard Medical Electronics Division in 1966 with BSEE and MSEE degrees from the University of Michigan. He worked on the 1501A Optical Coagulation Analyzer and designed an automatic device to measure and digitally display coagulation times. In 1968, he joined the telemetry project where he designed the mixer, IF amplifier, and low-frequency circuits. Dick's hobbies are gardening, hiking, and bridge. He and his wife have two children.

Alfred M. Nardizzi

Al Nardizzi joined Hewlett-Packard's Medical Electronics Division, then the Sanborn Company, in 1961 as a co-op student from Northeastern University. After earning his BSEE from Northeastern in 1965, Al joined HP full time and continued his education at MIT under the HP Honors' Co-op Program, earning his MSEE in 1967.

At HP, Al worked on the 8821A 8-Channel Amplifier before joining the telemetry project. At the end of the project, he transferred to production engineering to speed release of the telemetry system to manufacturing.

Al spends his free time as a member of the Jaycees. Basketball and softball along with family camping trips with his wife Pat and their three children round out the rest of his activities.

Richard Tverdoch

Rick Tverdoch joined Hewlett-Packard in 1967 after earning a BSME degree from Cornell University. He has since pursued further studies at MIT.

Most recently he designed the case and mechanical structure of the 78100A ECG Transmitter and the 78101A Receiver. Previously, he worked on the stylus and drive of the 7825A Trend Recorder and the 7826A ECG Recorder.

During the sub-arctic New England winters, Rick hibernates on local squash and handball courts. During the summer months, he and his wife can be found amongst the moose and big horn in our National Parks.

A Human Interface for Automatic Measurement Systems

This system console enhances a user's ability to operate a measurement system.

It features a magnetic tape cassette operating system and an interactive graphic display.

By Kenneth A. Fox, Marc P. Pasturel, and Peter S. Showman

THE MAN-MACHINE INTERFACE in a computer system can be as simple as a switch register and a row of lights or as sophisticated as the control panel of HAL the computer in the motion picture *2001*. Somewhere between these extremes is the proper human interface for a computer-based automatic measurement system. Such an interface should make programming more efficient by speeding up or eliminating mechanical functions; it should make the system easy to operate even for relatively unskilled operators; it should help the user cope with the large volume of data produced by the system by displaying the data in a convenient format; and it should do all this at reasonable cost.

Model 8500A System Console, Fig. 1, is an expandable terminal designed to serve as a human interface specifically for automatic measurement systems. The console is visually, dimensionally, and functionally compatible with most HP automatic systems. Its first use has been with automatic spectrum analyzer¹ and automatic network analyzer systems.

In its minimum configuration the console includes a silent keyboard for user input, a magnetic

tape cassette unit for program and data storage, a 30 character/second thermal printer for hardcopy output, and a control panel for operator use. Functionally the minimum system replaces the ubiquitous

teleprinter-based paper-tape system, but it provides greater flexibility and speed as well as silent operation. The magnetic tape cassette unit and its software operating system virtually eliminate tape handling. This unit and the fast printer streamline the process of program development, while the keyboard and control panel contribute to a system's ease of operation.

Depending upon his application, the user may include an interactive graphics option, which provides graphic and alphanumeric output on a CRT display. A feature of this option is a trackball-controlled cursor which simplifies control of the system. In most cases the interactive graphic display is the best solution to the problem of extracting the useful information from the large amount of data the system produces.

The console can draw solid or broken vectors or plot individual points, and simultaneously display alphanumeric information such as labels for



Fig. 1. Model 8500A System Console is designed specifically for use with automatic measurement systems. The complete console is contained in one rack, which also has space for the system computer.

graph axes. The number of points, inches of line, and characters that can be displayed is more than sufficient for automatic measurement systems; however, the console isn't designed for drawing complex pictures such as IC layouts.

Included in the interactive graphics option is an interface to a commercially available printer/plotter. The printer/plotter can produce a permanent record of anything displayed on the CRT.

Dimensions of the system console and placement of the keyboard, CRT screen, and controls are based on static and dynamic anthropometric data from various sources and on experiments with HP personnel. A wide range of operators can be accommodated comfortably.

Fig. 2 summarizes the benefits of the system console for the system operator and the measurement engineer.

Operating the System

With the 8500A System Console, the user can direct the progress of measurement programs in a variety of ways. The keyboard is available for textual or numeric input, such as yes/no responses or setup data. The control panel contains special functions which are useful in nearly every measurement program. PAUSE/CONTINUE buttons temporarily suspend measurements when it's necessary for the operator to take some action, such as connecting a device to be tested. Two TRAP buttons allow the operator to stop execution of one part of a program and begin execution of another part. A button is provided to produce hardcopy of whatever is on

the screen, and a set of sense switches is provided for general use.

The trackball-controlled cursor is a somewhat unusual means of communicating with the system. The cursor is a small cross on the screen which can be moved about by rotating the trackball located near the keyboard. The operator uses the cursor to point at data on the screen—for example, to select an item from a menu of items printed on the screen, or to specify a part of a graph which should be updated or expanded.

The computer can read the cursor's position as well as its proximity to other data on the screen. The operator normally tells the computer to read the cursor by pressing the MARK key on the keyboard. As an example of how the cursor can be used, Fig. 3(a) shows an amplitude-versus-frequency plot measured by an 8580A Automatic Spectrum Analyzer. The system is continuously remeasuring and replotting the spectrum while waiting for the operator to direct the next task with the cursor. In the upper righthand corner of the screen is a list of bandwidths for the measurement system. The user can select a new bandwidth by pointing to it with the cursor and pressing the MARK key. New frequency limits for the measurement can also be selected. The user moves the cursor to the starting frequency, presses the MARK key, and repeats the process for the stop frequency. Fig. 3(b) shows such an expanded spectral plot.

In many measurement processes an operator must follow a lengthy procedure, perhaps to calibrate the system or to set up a measurement. With the

8500A USER	INTERACTIVE FEATURES	GRAPHIC FEATURES
System Programmer (usually the test engineer)	<ul style="list-style-type: none"> • Instant listing on CRT • Instant program editing in BASIC • Hardcopy listing at line-printer speed • Cassette operating system 	<ul style="list-style-type: none"> • Graphics software package. Compact graphic calls make graphs and interaction simple to program
System Operator	<ul style="list-style-type: none"> • Trackball-controlled cursor gives untrained operator finger-tip control of the most complex measurement system (e.g., by pointing to a 'menu') • Convenience of cassettes which can be used for data storage and retrieval, quietly and without operator intervention • Blinking messages or graphs to attract operator's attention 	<ul style="list-style-type: none"> • Data reduction and analysis is best aided by graphs. Up to seven can be simultaneously displayed. • Operator instructions can be presented graphically (e.g., step-by-step connection diagrams) • Graphics hardcopy provides best record for future reference. Can include graphs, text, tables.

Fig. 2. Capabilities of the system console from the viewpoints of the two types of user.

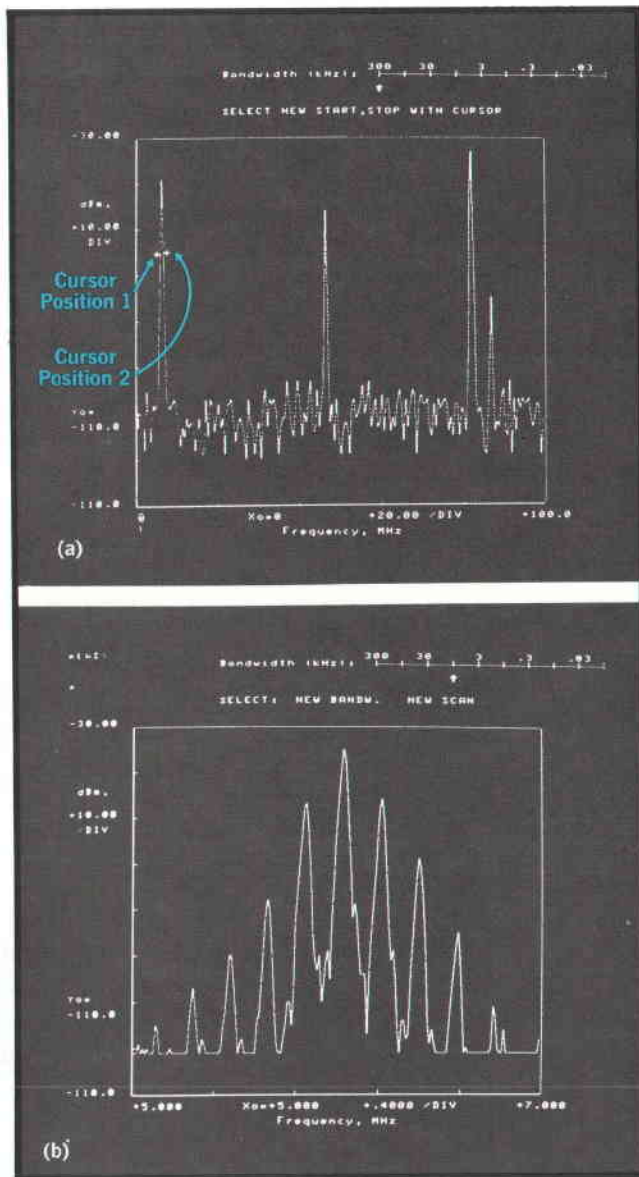

Fig. 3. System console display of an amplitude-versus-frequency plot measured by an automatic spectrum analyzer. Operator can call for new measurement conditions by bracketing part of the display with the cursor. For example, marking positions 1 and 2 with the cursor causes the display to change to the expanded plot at right.

8500A, the system can draw diagrams of the required connections, leading the operator naturally through the measurement task. Critical parts of the diagram can be made to blink to catch the operator's attention. Fig. 4 shows a test set connection for an 8545A Automatic Network Analyzer program.

Easy Programming

The 8500A System Console greatly simplifies the programmer's task, and this is important because

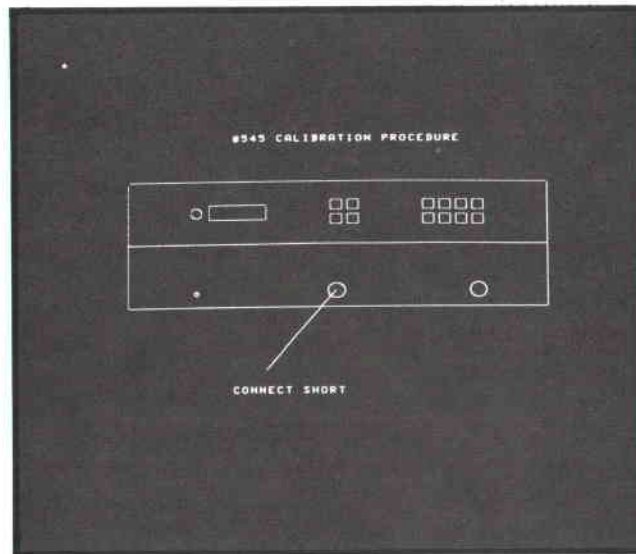

Fig. 4. Console can be programmed to lead an operator through a calibration or measurement sequence by showing him what connections to make. This is an example from an automatic network analyzer program.

the programmer is usually the measurement engineer and not a specialist. The console software provides access to the system's capabilities without requiring extensive training. The Cassette Operating System (COS) establishes an environment for preparing and running programs in BASIC, FORTRAN, ALGOL, or Assembly languages. At the heart of COS is the EXEC, which combines facilities for tape handling and for loading and executing other programs such as the FORTRAN compiler or user-written programs.

The cassette unit makes it easy to enter, save, and retrieve programs or data. No threading process is required. Loading a cassette is a simple matter of inserting it and locking it in place.

With the graphics option the programmer can maintain the latest program listing on the screen at all times. Hardcopy of program listings or output can be obtained at the push of a button.

Programming the system is straightforward in any of the four languages. BASIC is a good example. BASIC for the 8500A system is syntactically the same as HP BASIC with additional statements applying specifically to the 8500A. Programming for textual output such as program listings or data is done just as it is in standard HP BASIC.

Programming Graphics in BASIC

The simplicity of doing graphical output is best illustrated by example. Fig. 5(a) shows a complete BASIC program to plot $\sin(x)/x$. The output is shown in Fig. 5(b). In this program, statement 10

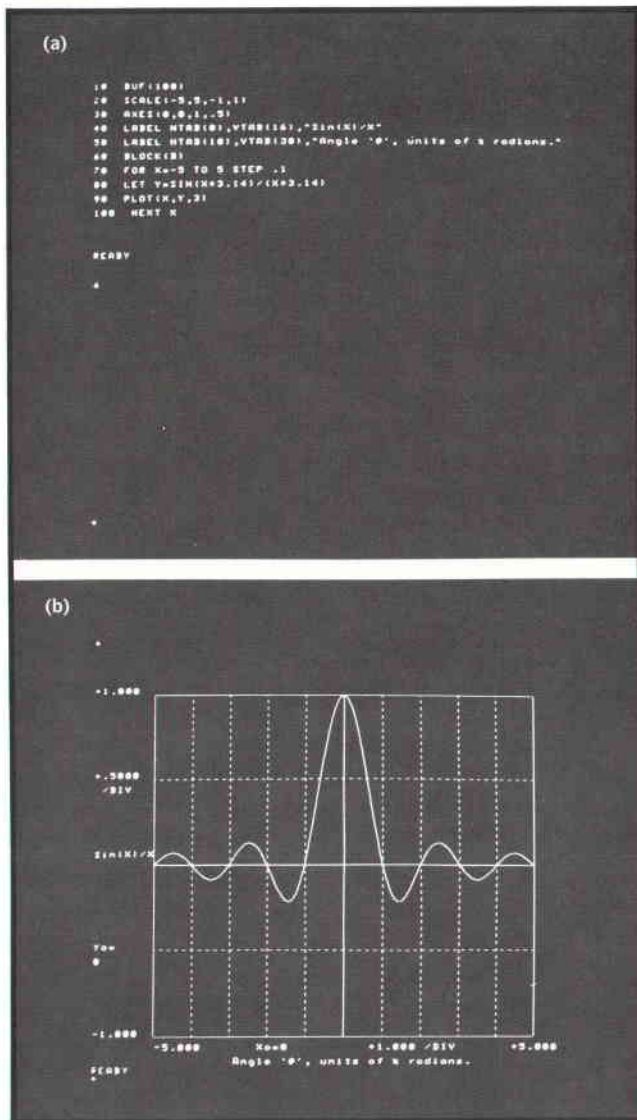

Fig. 5. Power of system console software is demonstrated by this relatively short BASIC program to produce a graph of $\sin x/x$. Console can be programmed in FORTRAN or ALGOL, too.

allocates 100 words of the display buffer to text. The display buffer is a 600-word area in the computer's core memory which is used to store a description of the picture to be displayed (more about this later). Statement 20 sets up the plot scales (-5 to 5 horizontally, -1 to 1 vertically). The axes and grid are drawn by statement 30, in which the first two parameters specify the coordinates of the point where the axes cross, and parameters three and four specify the number of units per division. Statements 40 and 50 label the axes. The functions HTAB and VTAB are horizontal and vertical tabs (in character and line spacing) and are used here to position the beam prior to writing the text enclosed between

quotation marks. Statement 60 tags the graph data and causes the first point to be drawn with a blank vector, so the first solid vector drawn by statement 90 doesn't originate from some random part of the screen. Statements 70 through 100 are a FOR/NEXT loop for computing and plotting the function. Statement 90 draws a vector from the end of the previous vector to the position X, Y in the scale specified by line 20. The third parameter in this statement specifies the type of vector to be drawn—blank, dotted, dashed, or solid.

Refreshed Display

The CRT in the 8500A is not a storage tube. Rather, the display is refreshed periodically. The main reason for having this kind of display is so that portions of the display can be modified without disturbing the rest. This is necessary for interactive use of the display, a useful operating mode for both laboratory and production applications (for example, circuit adjustments can be made while watching the results on the display). Another reason for wanting a refreshed display is that it's more visible than a storage display in normal ambient light.

In a refreshed display system, a description of the picture to be displayed must be stored in a memory and scanned approximately every 20 milliseconds to keep the display from flickering. In the 8500A, it was decided to use a portion of the computer memory to store this description, for two reasons. It's much easier to manipulate data in the computer's main memory than in an external memory, and the cost per bit of the relatively large computer memory is less than for a smaller, separate memory. (Of course, since the display is intended for automatic systems, there is always a computer present.) To avoid overburdening the processor, display instructions are transferred from memory under control of the computer's direct memory access (DMA) logic. The instructions supplied by DMA are processed by a display generator into analog voltages which drive the X, Y, and blanking inputs of a fast electrostatic CRT (see article, page 18).

When an output device such as a printer is used with a computer, a PRINT statement in BASIC causes information to be sent from the computer to the printer through the I/O system. In this CRT system, since the information being displayed is contained in the computer's memory, output operations to the CRT display do not directly cause information to leave the computer, but simply move it from its original location into the display buffer,

which is the portion of the computer's memory that is used for storing display information. The next time that portion of the buffer is refreshed, the new information will appear on the screen. Since moving data from one place in core memory to another takes only microseconds, updating the display is very rapid; in fact, the entire display can be changed in 20 milliseconds.

Display Software

The software required to put the desired information on the screen includes the user program, which determines the actual information presented, and system software, which performs housekeeping tasks and determines the tools available to the user program.

Instructions are transferred to the display generator under control of DMA hardware, but DMA itself is under software control. Direct memory access functions in a block-transfer mode—that is, it is given boundaries in the display buffer of a block of data to be transferred, and then is started. Part of the system software is a subroutine that supplies these boundaries, or pointers, to the DMA logic as they are needed. This subroutine maintains a refresh table, which lists all the memory segments whose contents describe parts of the picture to be displayed on the CRT. This table is constructed from the user's program and changes continually as the program is executed.

Transfer of data from its original location into the display buffer is performed by a subroutine called the buffer management routine. This portion of the system software is also responsible for supplying updated pointers to the refresh table. It is this subroutine that ultimately responds to user instructions and therefore determines the capabilities of the display from the user's viewpoint.

The 600-word display buffer is divided into two sections, a text buffer and a graphics buffer, separated by a boundary which can be moved by the programmer. The text buffer is used for alphanumeric information that would go to the printer in a non-CRT system. The user's options are to set its length, to add to its contents (via `DSPLAY` statements in `BASIC` and `WRITE` statements in `FORTRAN`), and to clear it. Information is always displayed in the order received. If no length is set, it is assumed to be 600 words.

The user program relinquishes part of the 600 words to graphical data by means of a `BUF` statement, which sets the length of the text buffer. The graphics buffer uses that portion of the display buffer not claimed by the text buffer. As its name im-

plies, the graphics buffer is used for all graphic information, but it may also include alphanumeric characters in the form of labels. Graphical data may be entered in much the same way as characters are entered into the text buffer, that is, without knowing the location of the information within the graphics buffer. However, the user is given much more power to control and manipulate data in the graphics buffer if he wishes. Buffer entries need not be stored in the order in which they are received, and an individual entry (element), such as the instruction for a single vector, may be readdressed, examined, and modified or erased. To make it easier to locate such an element, the programmer may tag various locations in the buffer, and then address elements in the block of words following the tag by their positions relative to the beginning of the block. This feature is useful for selectively updating portions of a display by replacing specific elements (e.g., a vector) within a block. Fig. 6 shows an example in the communications field. An 8580A Automatic Spectrum Analyzer is continuously monitoring a portion of the spectrum by tuning to selected frequencies (channels) and recording the presence or absence of a signal. This information is converted to channel occupancy and displayed as a bar graph. As new information is collected, portions of the display are updated, giving a dynamic picture of the use of the spectrum.

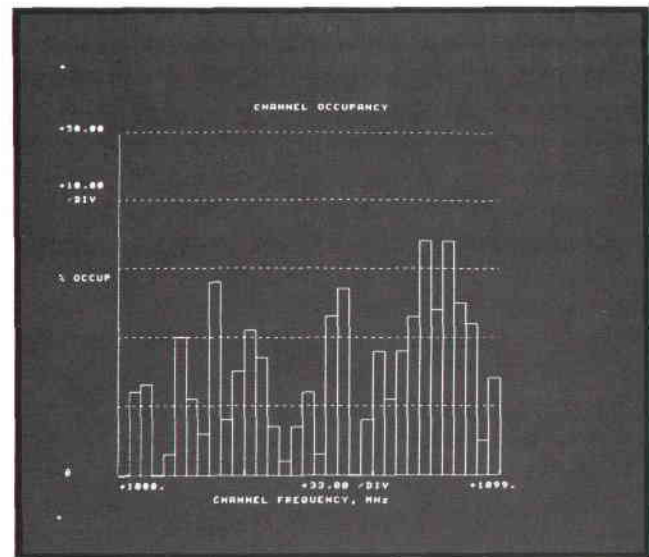

Fig. 6. CRT display is refreshed every 20 milliseconds based on data stored in display buffer. Buffer can be divided into blocks, and the system software provides for replacing specific elements (e.g., a vector) within display-buffer blocks. For example, occupancy levels for individual channels can be updated separately, without replacing data for other channels.

If several blocks are set up in advance, the buffer management routine will keep track of the next available memory word in each block. This is useful when blocks are being filled simultaneously (for example, when drawing graphs in parallel).

By using appropriate statements the programmer can enter data into the buffers, set up block boundaries, move the next-entry pointer in the graphics buffer, clear any block or the entire buffer, and inhibit refresh of any block. The programmer can also access the cursor and the control panel, and can read and write on the cassette unit. All these capabilities are available in FORTRAN, ALGOL, and BASIC.

CRT System Design

What is required of a CRT display to be used with an automatic measurement system? A basic requirement is a display of one or more graphs representing measured data, on either a polar or rectangular coordinate system. It was felt that a display that could draw up to five simultaneous graphs with, say, 50 data points each, or fewer graphs with perhaps 200 points each, would be sufficient for most needs. Previous experience with an 8-bit, dot-only display (256×256 positions) indicated that a display capable of interpolating between data points and with somewhat better resolution was needed. A resolution of 1024 points (10 bits) was chosen as the best compromise.

Second, since the user must write computer programs to tailor the system hardware and software to his needs, the display must be able to display enough alphanumeric characters to allow each statement of a program to be seen in context. This requires that 20 to 30 statements be displayed simultaneously. Measurement results must also be displayed in tabular form, but the required number of characters is no greater than for programming, since graphic output is available.

Analysis of the graphical requirements leads to an interesting conclusion—namely, that the amount of graphical information needed is typically much less than for applications such as IC layout or other complex picture-drawing. For example, the display shown in Fig. 7 requires 62 inches of line for the graphs, 59 inches for the grid, and 82 characters for the labels. The total number of line segments is 209. The text requirement, for 20–30 program lines, translates into a need for 800 to 1200 simultaneous characters, assuming an average of 40 characters per line. (By way of comparison, many general-purpose graphics displays are capable of displaying 10,000 inches of line, or 4000 characters.) This lim-

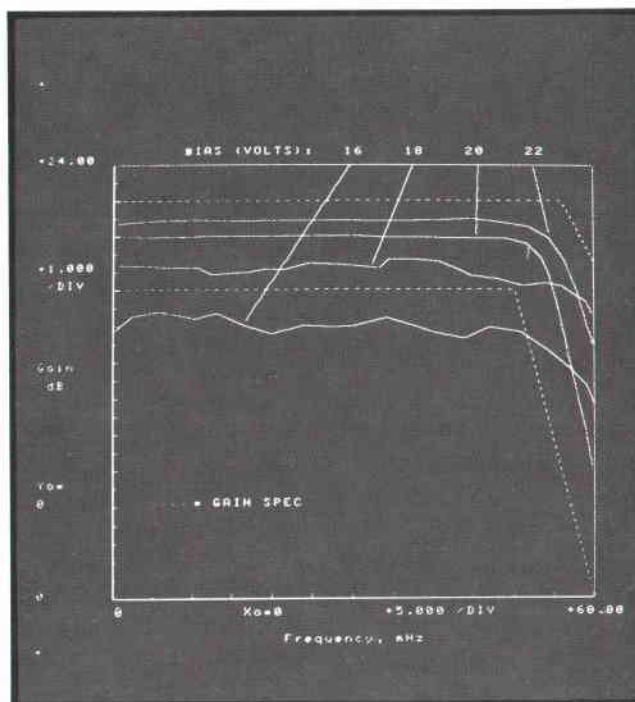

Fig. 7. Block structure in display buffer is also used for displaying multiple graphs simultaneously as shown here. Individual graphs can be updated without affecting others.

ited requirement means that a less expensive display will suffice, other things being equal. The 8500A can display up to 1200 characters or 300 inches of line, more than enough for most measurement-system uses.

A block diagram of the CRT subsystem is shown in Fig. 8. The 16-bit words supplied to the display generator describe the image on the CRT. The information sent from the display generator to the computer includes data on the beam position (for use in making hardcopies) and information about the position of the cursor and its proximity to other visible objects on the screen. The cursor is used as a pointer by the system operator, and the cursor information is used in editing and otherwise interacting with the display.

The format used to represent the visual display in memory has been made as compact as possible, both to minimize memory size and to reduce the amount of time it takes to transfer data from memory to the display generator. The format, which is defined by the display generator instruction set, is compact enough that typically less than 5% of the computer's time is spent on display system overhead.

Display generator instructions fall into two categories: graphic and alphanumeric. There are three general types of graphic instructions.

- **Setpoints** move the beam immediately to the specified new position. The beam may be turned on momentarily after a settling delay.
- **Absolute vectors** move the beam to the specified new position along the straight line. The beam may be off, on, or modulated at either of two rates to create broken lines.
- **Incremental vectors** move the beam through specified X and Y increments along a straight line, with beam control as above.

In addition, there are some special vector types useful for describing graphs compactly.

Alphanumeric instructions are always in the form of two ASCII characters packed in a 16-bit word. Upper and lower-case characters are provided, and Greek letters are also provided as part of a special character set. Also included in the set of characters are control characters that perform tabs, cause portions of the display to blink, and initialize the display.

Display Generator

The display generator receives the 16-bit words sent by DMA, determines the type of instruction based on an operation code, and activates hardware which draws characters, vectors, or points. All visible objects are drawn point-by-point. Characters are drawn on a 5×7 dot matrix, which is shifted for descending characters, such as lower-case p and q. Vectors are drawn by repetitively moving the CRT beam one position, letting it settle, and then unblanking the CRT. This operation is controlled by a modified binary rate multiplier, which gives a good stepwise approximation to a straight line. Although drawing with dots rather than strokes is relatively slow, it makes cursor operation and digi-

tal hardcopy much simpler. This is because the hardware has full knowledge of the beam position at all times, and this information can be returned to the computer either for normal operations or for diagnostics.

Acknowledgments

George Powch and Dave Stallard did most of the logic design of the character and vector generators. Chuck Thomas and Dick Lampman designed the cursor control and worked on the bus I/O system. Dave also designed the interfaces for the other system peripherals. Yas Matsui and Phil Foster did the industrial and product design on the console and the component instruments.

Orrin Mahoney and Janelle Stribling developed the cassette software and the prototype software for the 8500A. Ann Cole and Sue Slayen have developed the final 8500A software package. Marge Duncel provided long hours of program preparation support.

Jake Egbert smoothed the 8500A's path to production. ☺

References

1. M. Cunningham and L. Wheelwright, 'Introducing the Automatic Spectrum Analyzer,' Hewlett-Packard Journal, February 1972.

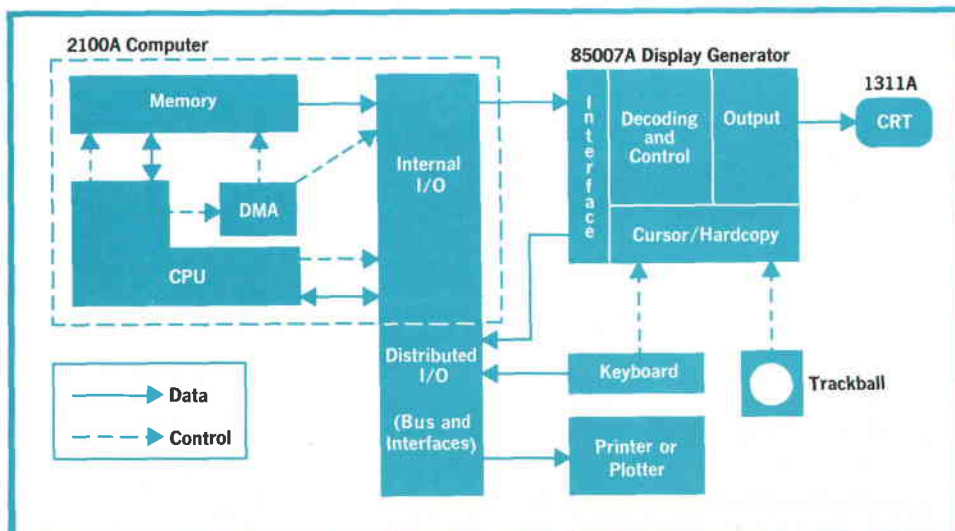

Fig. 8. CRT subsystem is designed to have a compact data format, so typically less than 5% of the computer's time is spent servicing the display.



Kenneth A. Fox

Ken Fox is a 1966 graduate of Harvard University with an A. B. degree in engineering and applied physics. After Harvard, he decided to try for a doctorate in electrical engineering at the University of California at Berkeley, but three years later he settled for an M. S. and came to work at HP. He's project leader for the software that makes the 8500A System Console operate. After working hours Ken's a motor freak, putting in many hours touring on his BMW motorcycle or acting as pit crew for a friend who races a TR4. He used to sail, ski, and play tennis, but motorcycles and sports cars have all but eliminated these activities. Not by gasoline alone doth man live, though. Ken's a book freak, too, and usually has a novel close by to jump into when there's time.

Marc P. Pasturel

Born near Toulouse in southwestern France, raised in Casablanca, Morocco, educated in Lyon, France and Palo Alto, California, married to a Norwegian engineer—that's the cosmopolitan background of Marc Pasturel of HP's Microwave Division. Marc received his Diplôme d'Ingénieur (Electronique) from the Institut National des Sciences Appliquées in Lyon in 1962, then came to the U. S. and got his M. B. A. degree from Stanford University in 1964. Two and a half years as a production engineer came next, first in Dallas, Texas and then in Nice, France, and after that a year in the French Navy. Drawn back to Palo Alto, Marc joined HP in 1968. He's now a product marketing engineer, responsible for developing applications for the 8500A System Console. Away from work, family activities seem to take the lion's share of Marc's time, but he heads for the tennis courts or the ski slopes whenever an opportunity presents itself.

Peter S. Showman

Pete Showman is project leader for the hardware design of the 8500A System Console. Electrical engineer and IEEE member Showman holds B. S. E. E., M. S. E. E., and E. E. degrees, the former received from Cornell University in 1965 and the latter two from Massachusetts Institute of Technology in 1967. His first project after joining HP in 1967 was interfacing the 8410A Network Analyzer to a computer for the 8542A Automatic Network Analyzer System. A member of the HP Sailing Club, Pete races his El Toro against other club members once a week on summer evenings. He enjoys sports car racing, too, but only as a spectator. Other diversions include learning to ski and playing the guitar, the latter sometimes for friends, sometimes just for relaxation.

Summary of Characteristics HP Model 8500A System Console

KEYBOARD

Solid State, 96 ASCII characters
"MARK" for cursor position interface through software
Editing, Blink Control Buttons
Cursor Control

CASSETTE INPUT/OUTPUT UNIT

Three Decks—Read/Write Speed: 500 cps.
Cassette Storage: 90k words (16 bits) per side
Guaranteed deck-to-deck compatibility

PRINTER

Alphanumeric, 30 cps
Type: Thermal

CONTROL PANEL

BUTTONS:

BREAK: Interrupts and restarts the program being executed
TRAP 1, TRAP 2: Interrupt and branch the program.
PAUSE, CONTINUE: Pause and continue program execution.
COPY: Generates hardcopy.
PAPER ADVANCE: Controls the hardcopy unit

SWITCHES:

PRINTER: Routes all text output directly to the hardcopy unit.
UPPERCASE: Used in the programming mode.
8 SENSE SWITCHES: Used for program branching.
DIAGNOSTIC/NORMAL: Allows 'real time' analog display.
LIGHTS: 4 Light Indicators: can be set through software.

INTERACTIVE GRAPHICS CONSOLE (Optional)

CRT DISPLAY
Display Area: 8½ x 8½ Inches

Resolution: 1024 x 1024 Addressable positions
64 characters per line; 32 lines; 1200 characters flicker free
Blink mode

DISPLAY GENERATOR: characters, vectors, points.

96 ASCII characters—English upper and lower case
Special characters—Greek

Up to 300 in of flicker free vector length

Vector Addressing: Absolute, relative, auto-incremental

Vector Types: Solid, short and long dashes, blank

TRACK BALL (high resolution cursor control)

Type: Optical encoder, full 10-bit resolution

Printer/Plotter: Versatec Matrix 100 Plotter Interface

Alphanumeric and Graphic Hardcopy

Speed: Copies CRT in 15 sec. max. Prints @ 250 lpm.

Paper: 8½ x 11 inch fanfold

SOFTWARE

Cassette Operating System (BASIC, FORTRAN, ALGOL, Assembly)
Set of Graphic Subroutines.

PRICES

MODEL 8500A System Console is currently available as a peripheral to the 8545A Automatic Network Analyzer and the 8580A Automatic Spectrum Analyzer. Prices: \$14,000 for the minimum configuration (keyboard, printer, control panel, cassette unit, rack); \$10,000 for the interactive and graphics option (CRT, track ball and display generator).

MANUFACTURING DIVISION: MICROWAVE DIVISION
1501 Page Mill Road
Palo Alto, CA 94304

An Agile Graphic Display Device

Display area of 11 x 15 inches, 0.02 inch spot size, 50 ft-L brightness, less than 1 μ s large-step jump and settling time—until now no display device could simultaneously meet all these requirements, requirements that are needed as designers strive to cram more information into computer-generated graphic displays. The new Graphic Displays described here do indeed fulfill these requirements while adding some attractive features as a bonus: reduced bulk, lighter weight, lower power consumption and lower cost.

By John Rikken and Douglas Fogg

FOR DISPLAY OF COMPUTER-GENERATED DATA, the cathode-ray tube still reigns supreme. This is true for a number of reasons, chief among these being the flexibility of the cathode-ray tube—it can display an infinite variety of symbols in a variety of sizes, and it can also display graphs, curves, diagrams or anything else that can be traced by a movable dot. And, for readout of many-worded messages, it costs less on a per-symbol basis.

While brightness and resolution are excellent, there has been a limit to the number of characters or vectors a CRT can display at one time if the refresh rate is to remain above the flicker level. This is a consequence of the limited response speed of commonly-used deflection systems, which long ago were pushed to practical limits. Nevertheless, there is a growing demand for faster response, as system designers strive to place more and more information on display.

Much faster response can be had by using electrostatic rather than magnetic deflection, but this has not been practical for large-screen displays. This is because large-screen electrostatic deflection re-

quired either a very long CRT, or impractically high deflection voltages.

All this is now changed by further refinements in CRT expansion mesh electrode techniques, refinements that make electrostatic deflection feasible in a large-screen display without sacrifice of brightness or spot size. The expansion mesh electrode technique is applied in two new Hewlett-Packard large-screen, directed-beam graphic displays (Fig. 1), intended for use in display consoles and computer terminals.

The new Displays have much faster writing capabilities than was commonly available, giving a speed of response far greater than was thought possible for large-area displays.

The spot in the larger of these Displays (Model 1310A) can be moved from one corner of the 11 x 15 inch display area to

the corner diagonally opposite in 1 microsecond, including the time needed to settle within 0.02 inch (0.5 mm) of its final position. Formerly, at least 10 microseconds was needed. The speed advantage is not as great for smaller deflections but even for a deflection of 0.1 inch (2.5 mm), the ratio is 0.2 μ s for the new electrostatic system vs 1 μ s for older ones.

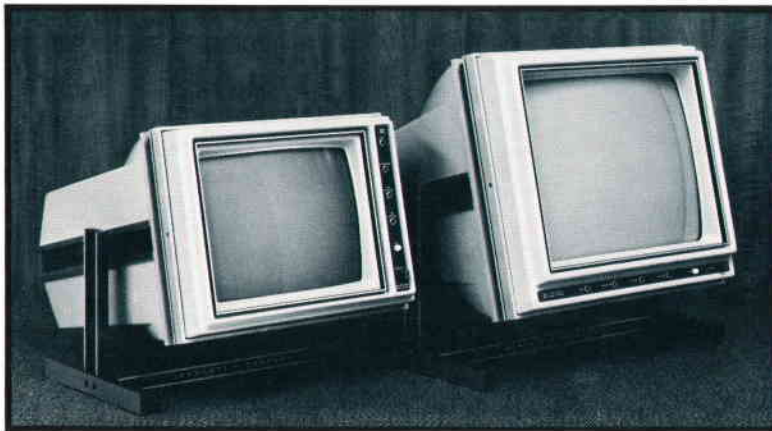

Fig. 1. New Graphic Displays have far less bulk and weight than the usual directed-beam display, while speed of response has been increased an order of magnitude. With optional covers and stands shown here they become free-standing instruments but they are easily installed in equipment racks and consoles. Model 1310A (right) has 11 x 15 inch display area while Model 1311A (left) has 8½ x 11 inch area.

As by-products of this development, weight and power consumption have been reduced significantly, features of special importance to those concerned with airborne displays. What's more, overall costs have been reduced.

Semidependent instruments

The new Graphic Displays include deflection and blanking amplifiers. They are designed for systems that have D-to-A converters and character generators that supply the analog voltages for driving the deflection systems. A 1-volt signal into the input of either the horizontal or vertical axis of these Displays drives the spot from one edge to the opposite edge. One volt into the Z-axis turns the beam from full off to full on. Spot size, comparable to a magnetically-deflected CRT, is less than 0.02 inch (0.5 mm) over 75% of the display area in the larger unit, and is less than 0.015 inch (0.4 mm) in the smaller one. The quality of the presentation is evident in the photos of displayed data on pages 12 and 13 of this issue.

High-density data

Now, with high-speed deflection available, the amount of displayed graphic data can be increased without reducing the refresh rate. Linear writing speed is better than 10 inches/ μ s (25.5 cm/ μ s) but the all-solid-state deflection amplifiers can move the spot at a rate greater than 100 inches/ μ s (255 cm/ μ s) when the spot does not need to be visible while moving. Because of the fast response to deflection signals, no delay is needed in the Z-axis circuit to synchronize beam unblanking with spot movement.

Capable of writing character strokes in less than 100 ns each, these Displays can refresh 4096 alphanumeric characters in less than 6 ms. Thus for a 60-Hz refresh rate, 10 ms of each refresh cycle would be available for display of other data. This makes it possible, for example, to superimpose characters on a video display. Point-plotting time for small steps is less than 200 ns per point, reducing the time needed for completing matrix type displays.

The fast response also simplifies system programming since vectors can be written in random fashion anywhere on the display, rather than necessarily in sequential order.

Loss of weight with fewer calories

The voltage drive of an electrostatic deflection system consumes much less power than the current drive of magnetic systems. Thus, overall power consumption of the new Displays is only 115 watts, as compared to 500 watts or so for others.

Lower power consumption means lighter transformers and related structural hardware. As a consequence, the new Model 1310A 11 x 15 inch (28 x 42 cm) Graphic Display, including deflection amplifiers and power supplies, weighs less than 53 pounds (24 kg) without covers, as compared to the usual 100 pounds (45 kg) or more. The Model 1311A, with a display area of 8½ x 11 inches (21.5 x 28 cm) weighs only 40 pounds (18 kg).

Framework

One of the most striking features of the new Displays is their mechanical design. The product designers made every effort to hold down costs by minimizing tooling and making it possible to assemble all units identically regardless of whether they were to be installed in a system or used free-standing.

The open frame construction shown in Fig. 2 resulted from this effort. Only two side rails, anchored firmly to the front panel, are used. These support the main deck. The circuit boards plug into a motherboard on the main deck and, as can be seen, are readily accessible for replacement. The CRT is anchored to the front panel.

The side rails can be mounted into a slide-rack mechanism or attached to a stand for freestanding applications. The covers are non-structural and can be attached or removed as needed by the intended application.

Shortening the CRT

The desired combination of speed, resolution, and brightness hinged on the development of a new cathode-ray tube. The first step was to increase beam current without increasing spot size. This was done by designing the electron gun to use an accelerating voltage of 4.5 kV, about twice that of high-performance oscilloscope CRTs.

Next came the deflection electrodes, always a compromise between sensitivity and bandwidth. Solid-state circuit developments have made a 300-volt deflection voltage practical at high frequencies, so the length and position of the deflection electrodes were designed to obtain 36° deflection with a 300-volt potential.

As the beam leaves the deflection region, it passes through the expansion mesh, a fine screen formed into a spherical surface. The mesh, held near ground potential, develops a voltage gradient in the post-accelerator region that bends the beam, the degree of bending being proportional to the amount of off-center deflection imparted by the deflection plates. The 36° maximum deflection is thus expanded to 90°.

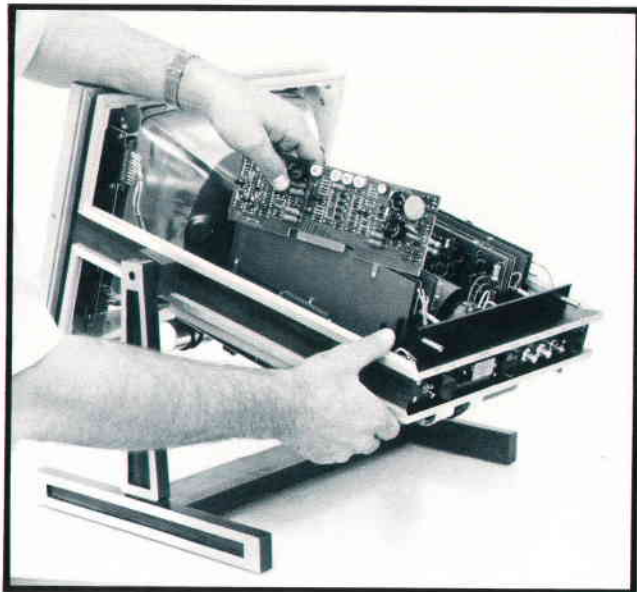

Fig. 2. Open-frame construction provides ready access to circuits. CRT compression band anchors to front panel, which serves as structural foundation. High-voltage connector is encapsulated to CRT, protecting service personnel from 24 kV accelerating potential. Low power consumption eliminates need for cooling fan.

After passing through the mesh, the electron beam is subjected to a 24-kV post-deflection accelerating voltage to give the desired brightness with small spot size. Any X-radiation resulting from the high accelerating potential is suppressed to the background level by the strontium-doped glass in the faceplate.

Since the gun and expansion mesh were designed to give 90° deflection, standard color-TV glass funnels and faceplates can be used, a big factor in keeping costs low. The steel rim band of these tubes, which places the faceplate under high edge-to-edge compression to increase the glass's resistance to implosion, performs extra duty as a device for mounting the 30-lb CRT solidly to the front panel.

Dynamic focusing

Designing a large-screen display becomes more than an exercise in scaling up small-screen parameters—little aberrations that are insignificant in a small display assume major proportions when magnified for large-screen display.

One problem is deflection defocusing, especially noticeable when wide-angle deflection is used with a low-curvature faceplate. Some defocusing results from the increased distance the beam travels to the faceplate as it is deflected away from center screen but when electrostatic deflection is used, additional

defocusing is caused by the voltage gradient between the deflection plates. The electron beam has a finite diameter so, in response to a deflection voltage, electrons near the positive plate are accelerated more than those near the negative plate. Electrons on the positive side thus stay within the deflection field a shorter length of time so at off-center positions, the electrons receive unequal deflections and the beam spreads.

Defocusing from both causes is corrected in the new Displays by changing the focusing and astigmatism voltages as the beam is deflected from center screen. A diode shaping network converts the linear deflection voltages into the parabolic voltages needed for proper correction.

Burn protection

Another problem: with the high accelerating voltage and beam current density of this tube, the beam would burn the CRT if it remained stationary while turned on fully. Automatic circuits, shown in Fig. 3, reduce the possibility of this occurring. Whenever the beam moves less than $\frac{1}{3}$ screen diameter within a 16-ms time span, a 100-megohm resistor is inserted in series with the CRT cathode. The resistor limits the beam current to less than 1 μ A. The spot is still visible but it is not so bright that it would immediately burn the CRT.

Since there may be situations where users would not want the beam current limited automatically, an internal switch is provided for deactivating the protection circuits.

Transient-free remote gain control

Yet another problem: transients in step-wise deflection voltages caused by a subtle thermal effect in voltage-controlled attenuators. One objective to be met was that all operator controls should be accessible from the front. This poses no problems for those controls that work with dc currents (e.g., Intensity, Focus, Position, etc.) but there is a problem with lead length in those that pass signals, i.e., Gain. Accordingly, electronic gain control is used in this instrument so that only dc current need be brought to the control panel.

But most electronic gain controls cause small perturbations in step voltage response, and perturbations as small as 0.1% of a large positioning step voltage are visible in this display.

These perturbations result from a thermal effect. Most electronic gain controls, in actuality attenuators, work by feeding the signal current into two transistors, one that passes a portion of the signal on to succeeding amplifier stages, and one that

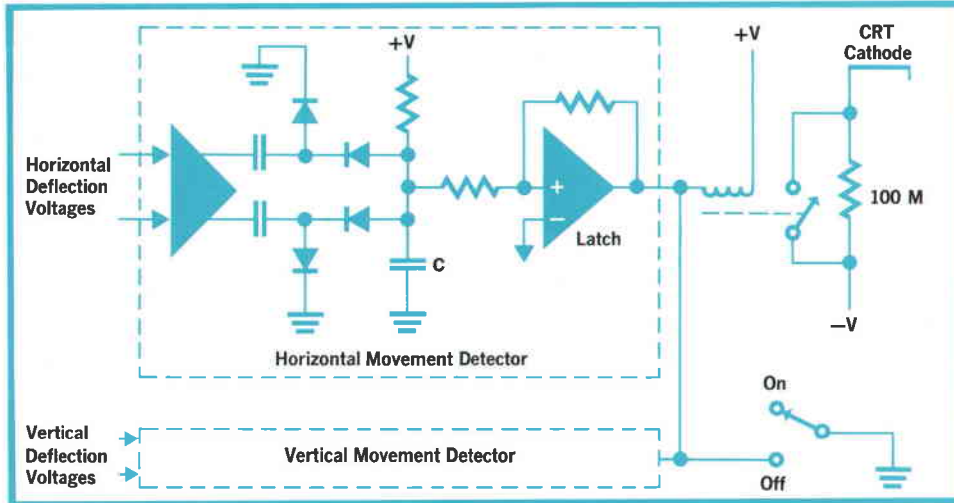

Fig. 3. Phosphor protection circuit responds to any change in push-pull horizontal deflection voltages by charging capacitor C negatively. Whenever voltage on C falls below trip point of latch circuit, latch draws enough current to close relay, bypassing 100M resistor. Similar circuit performs same function in response to vertical deflection voltages. Hence, beam movement of sufficient magnitude and speed in any direction closes relay, removing limit on CRT current. Time constant of capacitor C and hysteresis of latch circuits hold relay closed for 16 ms after beam movement stops.

sinks the remainder into a dummy load. Changing the base-emitter bias on one of the transistors affects the current division ratio and hence the signal attenuation. The problem is that a change in signal current, as well as a change in the bias ratio, affects the relative power dissipation in the two transistors. Thus within a few microseconds of a change in signal current, the transistor temperatures will change, causing an additional change in the current ratio. This temperature-induced change in current ratios causes perturbations in the step-voltage response of the deflection system.

This problem can be minimized if the transistors have equal power dissipation for all signal levels and for all values of attenuation. Analysis shows that this would happen if the transistor collectors were connected to sources with identical equivalents of Thevenin voltage and resistance (see Appendix). The circuit using this principle attenuates the signal over a 1.75:1 range with no loss in signal fidelity.

Deflection amplifiers

In designing the deflection amplifiers, speed of response was an important consideration but even more important was the need for deflection accuracy. The amplifiers must be able to position the CRT beam at a new location precisely, regardless of the beam's previous position. This means the amplifiers must be dc-coupled, eliminating coupling capacitors with their inherent time constants.

Considerable power economy is achieved by using an extension of an amplifier design used in other Hewlett-Packard CRT instruments: the amplifier with driven-current-source load.* The basis

of this amplifier is the use of a current source as the amplifier load. By linearizing the dV/dt of distributed capacitance, a current source load speeds up the circuit's response to a step change in signal.

A fixed current source, however, must continuously supply current equal to the maximum that may ever be required to charge the distributed capacitance. But, by driving the current source load with the high-frequency components of the deflection signal, the high current needed for quickly charging the distributed capacitance during fast transitions can be made available while the steady-state current can be quite low. The amplifier shown in Fig. 5 uses this technique.

The amplifier of Fig. 5 drives one deflection plate while the opposite plate is driven by an identical amplifier. The deflection plates of the other axis are also driven by a similar pair of amplifiers.

What about Storage Displays?

Cathode-ray tubes with storage capability do not need to be constantly refreshed, as do the non-storage displays described here. Since storage displays do not need refresh buffer sections in the computer's memory, their use requires far less memory. Neither do they 'steal' computer time for refreshing. Hence they are particularly useful in smaller systems that do not have discs or other large-scale memories.

The refreshed display, on the other hand, has significant advantages for most applications. For one, it can be selectively updated. This is particularly important for interactive terminals that use light pens, track balls, or other means of manually 'writing' on the display. Also, trace writing time is faster and at the present state of the art, the refreshed display is brighter than large-screen storage types, allowing it to be viewed in higher ambient light levels.

*Originally developed by Gregory Justice of HP Labs for the Model 191A TV Waveform Monitor.

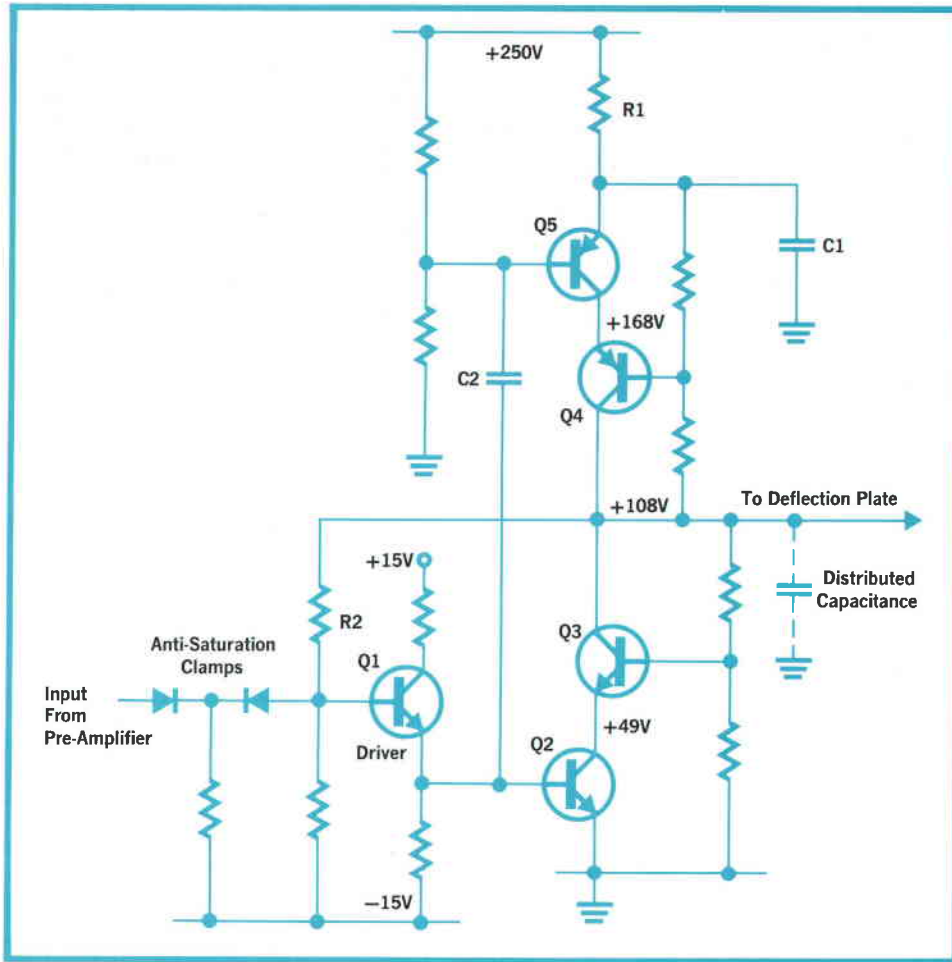

Fig. 5. Output stage achieves fast response without requiring large, steady-state currents. Transistors Q2 and Q3 form cascode amplifier, with negative feedback supplied to driver stage Q1 through resistor R2. Transistors Q4 and Q5, also connected in cascode, comprise driven current source. Steady-state current level is established by resistor R1 while extra current needed by fast transients is supplied by capacitor C1. High-frequency components of deflection signal are coupled to current source through coupling capacitor C2. Frequency response is 5 MHz.

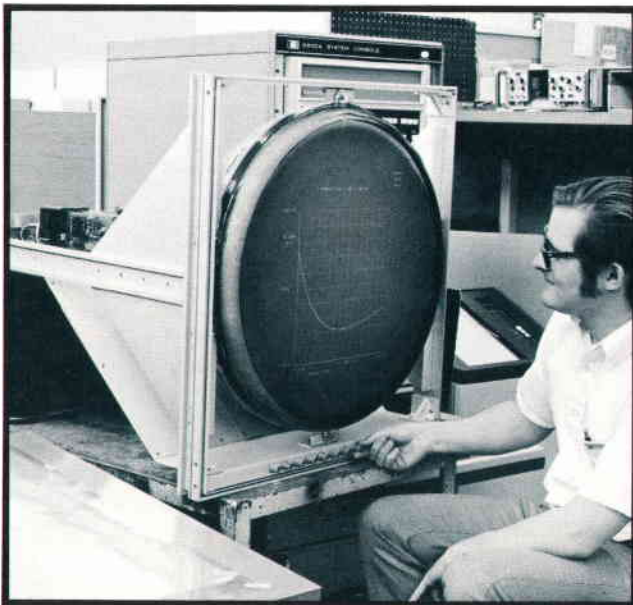



Fig. 4. Electron gun and deflection system are adaptable to any glass envelope with deflection angles up to 90°, as in this experimental round tube display. Mechanical framework is also easily adapted to other CRT types.

Conclusion

The high speed, low weight and low power consumption of these displays are real benefits for the ultimate user. Low weight and power consumption are immediate benefits but the speed of response will assume increasing importance as computer systems are designed to take advantage of it.

Acknowledgments

Much appreciation is due Milton Russell for the CRT design, without which this project would have been impossible. Appreciation is also due Bob Bell for guidance in product definition. Mechanical design was under the direction of Tom Schroth with industrial design contributions from Norm Tornheim. We also wish to acknowledge the contributions of Gene Severson, LaVern Gress, and Hal West for their help in keeping the project rolling. 

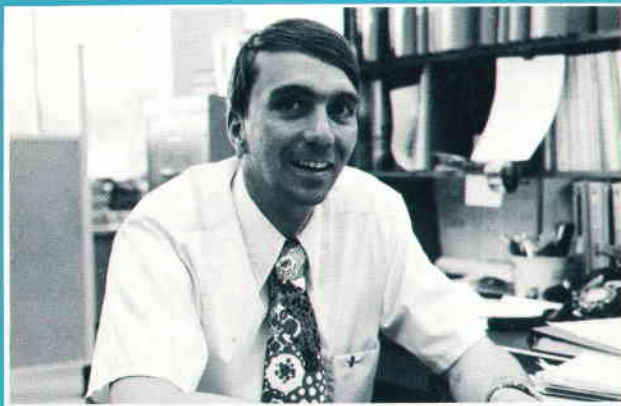

John W. Riggen

Born and raised in Colorado, John Riggen earned his BSEE degree at Colorado State University in 1960. He then went to work for HP in Palo Alto on the 1750A and 1751A plug-ins for the 175A Oscilloscope and on the 1402A plug-in for the 140-series Oscilloscopes. Along the way he earned his MSEE degree at Stanford University in the HP Honors Co-op Program.

John and the HP Oscilloscope operations moved to Colorado Springs in 1964. There he worked on the Model 141A Variable-Persistence Oscilloscope mainframe before moving into CRT design and production. With that experience, he was ready to take charge of the 1310A/1311A Graphic Display project.

John enjoys golfing and skiing.



O. Douglas Fogg

Another Colorado native, Doug Fogg earned his BSEE degree at the University of Colorado in 1964, where he was a member of Tau Beta Pi, Eta Kappa Nu, and Sigma Tau. Following graduation, Doug moved to Albuquerque where he designed radar transmitters and power supplies while acquiring his MSEE degree at the University of New Mexico.

Doug moved back to Colorado in 1967, going to work for HP designing circuits for the 141B/141T Variable-Persistence Oscilloscope mainframes and then for the 1310A/1311A Graphic Displays.

Doug enjoys the Colorado hills, skiing on them in the winter and riding his motorcycle cross-country over them in the summer.

Appendix Equalizing Power Dissipation in an Electronic Attenuator

An equivalent circuit for the electronic attenuator used in the new Graphic Displays is shown below. For this discussion, the collectors of Q4 and Q5 can be considered as tied together to an equivalent

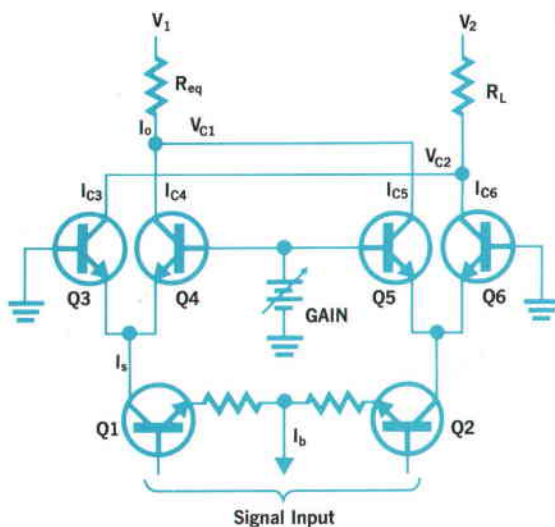

Thevenin voltage V_1 through an equivalent resistance R_{eq} , as shown in the diagram below. This is because these transistors normally drive a push-pull amplifier but since the emitters of this amplifier are tied together, their bases are essentially at the same voltage level. This voltage remains constant with differential changes in the Q4 and Q5 collector currents but will vary with common-mode changes, such as those caused by changes in bias.

Referring to the diagram, the power P_4 dissipated by transistor Q4 is:

$$P_4 = V_{c1} r I_s \quad (1)$$

where r is the fraction of current I_s that passes through Q4. The power P_3 in transistor Q3 is then

$$P_3 = V_{c2} (1-r) I_s \quad (2)$$

It is desired to make the power dissipation in these transistors equal for all values of r and I_s , where r is proportional to signal attenuation and I_s proportional to the input signal.

$$V_{c1} r I_s = V_{c2} (1-r) I_s$$

or

$$V_{c1} r = V_{c2} (1-r) \quad (3)$$

Because the transistor pair Q5-Q6 functions identically to the pair Q3-Q4, r is also the ratio of output current I_o to total current I_b .

$$\text{Thus, } V_{c1} = V_1 - r I_b R_{eq}$$

$$V_{c2} = V_2 - (1-r) I_b R_L$$

Substituting these values into equation (3):

$$(V_1 - r I_b R_{eq}) r = [V_2 - (1-r) I_b R_L] (1-r)$$

from which

$$r^2 I_b (R_L - R_{eq}) + r (V_1 + V_2 - 2 I_b R_L) + (I_b R_L - V_2) = 0$$

For this to hold true for all values of r , the coefficients of r^2 , r , and r^0 must all equal 0. Thus,

$$R_L = R_{eq}$$

$$V_1 + V_2 = 2 I_b R_L$$

$$V_2 = I_b R_L$$

$$V_1 = V_2$$

Hence

The same result would be obtained, of course, for transistors Q5 and Q6. Hence if $R_L = R_{eq}$ and $V_1 = V_2$, the transistors in each pair will maintain equal power dissipation for all input signals ($0 < I_s < I_b$) and for all values of attenuation ($0 < r < 1$).

SPECIFICATIONS

HP Models 1310A and 1311A Graphic Displays

VERTICAL AND HORIZONTAL AMPLIFIERS

RISETIME: 70 ns, 10% to 90% points for full-screen deflection or less.
BANDWIDTH: DC to 5 MHz (3 dB down at 5 MHz) with 3.5-inch deflection in 1311A and 5-inch deflection in 1310A.
PHASE SHIFT: $<0.1^\circ$ to 50 kHz and $<1^\circ$ to 250 kHz for full-screen signals.
LINEAR WRITING SPEED: >10 ln/ μ s
DIAGONAL SETTling TIME: Signal settles to within 1 spot diameter of final value in <1 μ s for any on-screen movement.
SEQUENTIAL POINT-PLOTTING TIME: Signal settles to within 0.01 inch of final value in <200 ns for any 0.1-inch step.
REPEATABILITY: $<0.15\%$ of full-screen error for re-addressing a point from any direction on screen.
CROSSTALK: <0.015 inch with one input shorted and the other input excited by 500 kHz.

DEFLECTION FACTOR:

	Vertical	Horizontal
1310A	1 volt for 11-inch deflection	1 volt for 15-inch deflection
1311A	1 volt for 8½-inch deflection	1 volt for 11-inch deflection

Horizontal and vertical deflection factors adjustable from front-panel control with attenuation of 1.75:1.

SPOT JITTER and MOTION: <0.025 inch.
POSITION: Zero input can be set to any on-screen position.
POLARITY: Positive vertical input moves beam up; positive horizontal input moves beam right. Polarity can be reversed by changing internal lead connections.
INPUT RC: Driven side 10k ohms shunted by <40 pF. Shield input is 47Ω to ground; this can be replaced with 10k ohms for differential input. Switchable 50-ohm termination between shield and center conductor is also provided.
MAXIMUM INPUT: ± 50 V (dc + peak ac) with 10k-ohm internal termination; ± 5 V (dc + peak ac) with 50-ohm internal termination.
LINEARITY: 1% of full-scale display along major axes.
DRIFT: 0.05 in/hr and 0.10 inch in 24 hrs with covers installed.

Z-AXIS AMPLIFIER

RISETIME: <14 ns.
SENSITIVITY: 1 V provides full blanking or intensity.
INPUT POLARITY: Internal switch selects polarity (switch is normally set so negative voltage unblanks signal).
GAIN ADJUST: Internally adjustable over 2.5:1 attenuation range.
BALANCE: Internal adjustment provides ± 1 V offset.
INPUT RC: Approx 10k ohms shunted by approx 60 pF. 50-ohm termination may be selected with internal switch.
MAXIMUM INPUT: ± 50 V (dc + peak ac) with 10k-ohm internal termination; ± 5 V (dc + peak ac) with 50-ohm internal termination.

CATHODE-RAY TUBE

VIEWING AREA

Model 1310A (19 in): 11 in high, 15 in wide.
 Model 1311A (14 in): 8½ in high, 11 in wide.
 CRTs of other sizes and shapes available on special order.
TYPE: Post-accelerator, 28.5 kV accelerating potential, P31 aluminized phosphor is standard (P4, P7, P39 aluminized phosphors available). Electrostatic focus and deflection.
SPOT SIZE:

	Spot Size in Quality Area	Size of Quality Area
1310A	0.020 inch	11" x 11"
1311A	0.015 inch	8½" x 8½"

RESOLUTION: 67 lines/in using shrinking raster method.
BRIGHTNESS: At least 50 ft-lamberts measured at 0.1 ln/ μ s, 60 Hz rate, with spot size of 0.020 inch on 1310A and 0.015 inch on 1311A.
CONTRAST RATIO: 4:1 or greater.
X-RAY EMISSION: CRT emission not measurable in background noise with Victoreen Model 440RF/C.
IMPLOSION PROTECTION: Rim and tension banding prevents implosive devacuation.
PHOSPHOR PROTECTION: Circuit detects absence of deflection and limits beam current.

GENERAL

X, Y, and Z INPUT CONNECTORS: BNC type mounted to rear panel.
WEIGHT
 Model 1310A: Net 53 lb (24 kg), with covers 59 lb (26.8 kg); shipping, 71 lb (32.2 kg).
 Model 1311A: Net 40 lb (18.1 kg), with covers 45 lb (20.4 kg); shipping, 62 lb (28.1 kg).
DIMENSIONS:
 Model 1310A: 19¼ x 16¼ in at front, by 26 in deep. 13¼ in wide at rear. (497 x 422 x 660 cm; 350 cm).
 Model 1311A: 16¼ x 12¼ in at front by 22¼ in deep. 13¼ in wide at rear. (426 x 329 x 578 cm; 350 cm).
OPTIONS
 003: Top and bottom covers with tilt stand (rack mount adapter not supplied with Option 003 instruments).
 005: Neutral-density contrast screen; improves trace contrast for easier viewing.

PRICES IN U.S.A.:

Model 1310A 19-inch Display\$3000
 Model 1311A 14-inch Display\$2875
 For prices of Displays with other types of CRT's, please contact your local HP Field Engineer.
 P4 or P39 phosphor in lieu of P31, no charge.
 P7 phosphor, includes amber filter; add \$50.
 Top and bottom covers with tilt stand, add \$100.
 Neutral density contrast screen, add \$40 for 1310A, \$30 for 1311A.
MANUFACTURING DIVISION: COLORADO SPRINGS DIVISION
 1900 Garden of the Gods Road
 Colorado Springs, Colorado 80907

HEWLETT-PACKARD JOURNAL

APRIL 1972 Volume 23 • Number 8



Technical Information from the Laboratories of Hewlett-Packard Company, 1501 Page Mill Road, Palo Alto, California 94304 U.S.A.
Hewlett-Packard S.A., 1217 Meyrin—Geneva, Switzerland
Yokagawa-Hewlett-Packard Ltd., Shibuya-Ku, Tokyo 151 Japan

Editorial Director: Howard L. Roberts
Managing Editor: Richard P. Dolan
Contributing Editors: Ross H. Snyder, Laurence D. Shergalis
Art Director: Arvid A. Danielson
Art Assistant: Erica R. Helstrom
Administrative Services: Ruth G. Palmer

HP Archive

This vintage Hewlett-Packard document was
preserved and distributed by

www.hparchive.com

Please visit us on the web!

On-line curator: John Miles, KE5FX

jmiles@pop.net

