

SEPTEMBER 1971

HEWLETT-PACKARD JOURNAL

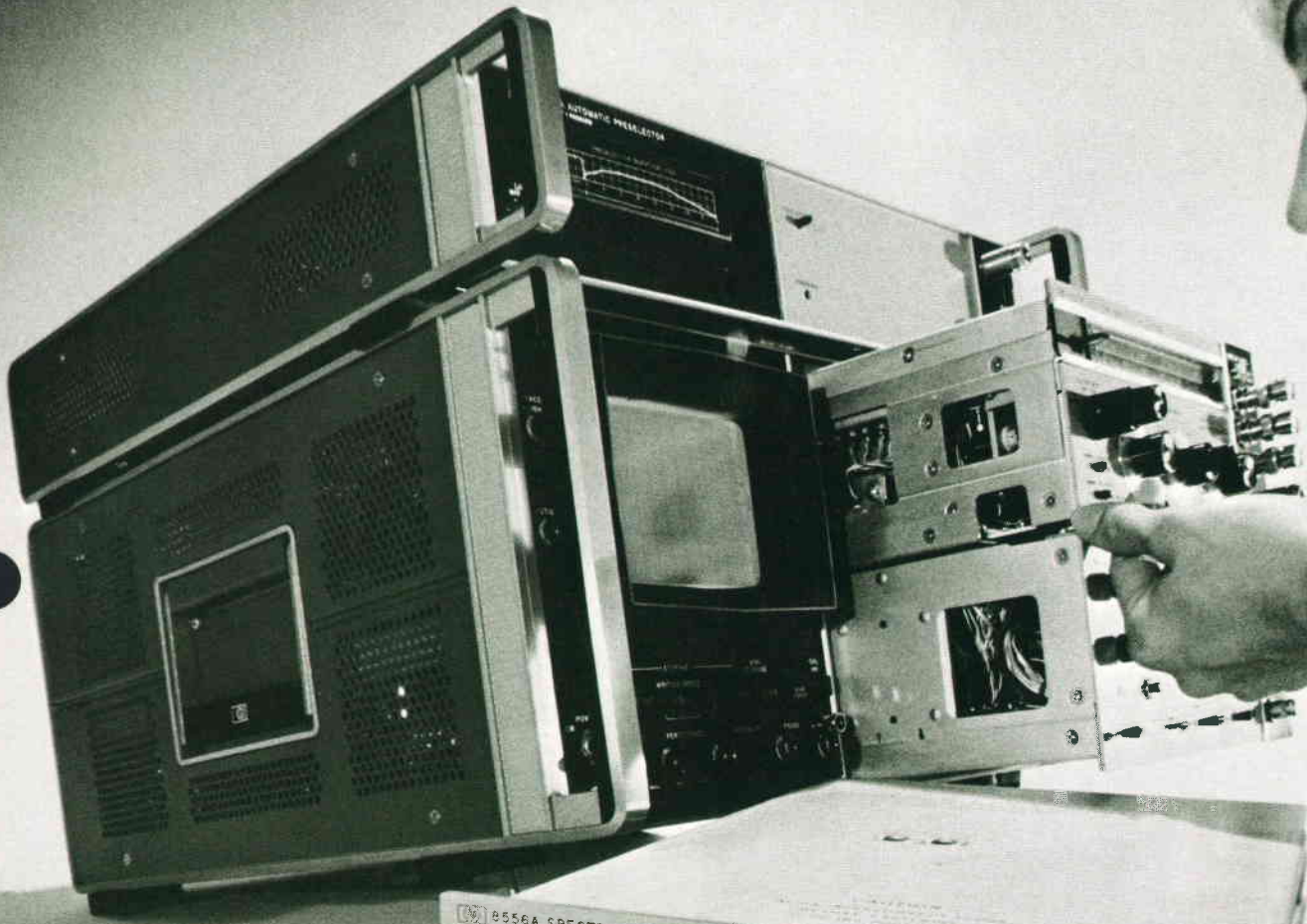

The Spectrum Analyzer, Oscilloscope For The Frequency Domain: A Special Issue

As the HP spectrum analyzer family adds new members, frequency range now extends from 20 Hz to 40 GHz. There are new tracking generators and a preselector. The family is reviewed, its new additions elaborated.

The spectrum analyzer's CRT, displaying the important parameters, amplitude and frequency, makes the frequency domain immediately visually accessible, just as the oscilloscope gives access to the time domain (amplitude versus time). The modern spectrum analyzer, absolutely calibrated in all respects, is many instruments in one. It makes many of the same measurements as a power meter, selective voltmeter, wave analyzer, distortion meter, frequency meter, and swept measuring system. More important, it displays these measurements simultaneously. If signals are complex, containing energy at many frequencies, the analyzer can display all at once. Then, like a microscope, it can "zoom in" for a close look, show individual components of a signal, or analyze stability and noise. Amplitude and frequency measurements are also fundamental in testing networks for distortion, intermodulation, and swept frequency response. The accompanying scope photos demonstrate these capabilities.

Absolute Amplitude Calibration

A contribution of this generation of spectrum analyzers is *absolute calibration*. If the analyzer's vertical scale directly indicates signal levels in absolute terms (e.g. dBm or millivolts) under all operating conditions, it may truly be called "absolutely calibrated." In the new generation of HP spectrum analyzers indicator lights always display the CRT's calibration and properly account for the setting of the input attenuator, the IF step gain control, and the IF vernier control.

This is of real convenience to the user, and it is something new; it was not found in earlier HP analyzers and it is not found in others. It is of value anytime a system's performance is level-dependent. A typical example is distortion measurement. Only if the instrument has a scale factor of 10 dB/division can signal differences, and hence distortion, be read directly from the CRT. The absolutely calibrated analyzer also, at the same time, shows exactly how many dBm were required to create that level of distortion. Another good example is in using the analyzer to characterize oscillators. Besides signal purity, it is often important to know if output level is sufficient to drive some following level-dependent device, such as a mixer. Absolute calibration is a great convenience in measuring system gains, especially where the system has frequency conversion stages. Signal levels at each point in the system can be quickly checked without mentally keeping track of analyzer control settings.

To be meaningful the absolute calibration must, of course, be accurate. This means frequency response must be substantially flat at all levels and that amplitude changes may not occur when resolution (bandwidth) is widened or narrowed. To increase confidence, a built-in amplitude calibrator has been included. It functions much like the square wave calibration found in better oscilloscopes.

Modularity

The illustration shows how the four new instruments described in this issue fit into the plug-in family. The new instruments are the 8556A Low Frequency Tuning Section,

the 8555A Microwave Section, the 8444 1300-MHz Tracking Generator, and the 8445A Automatic Preselector.

Each spectrum analyzer is made up of a tuning section, which determines the frequency range, and an IF section which determines resolution. Both plug into a display. Companion instruments like tracking generators or preselectors add extra measurement capability to the basic system.

Modular, plug-in RF and IF sections make it possible to select a range of frequencies and resolutions appropriate to any particular situation, without over-equipping. Yet additional frequency coverage may be added at any later time with other tuning sections. A variety of mainframes makes it possible to choose size of display, up to 12 inches, or to elect variable persistence, especially useful for slow scans. Companion tracking generators make it possible to add capability to make swept frequency measurements of very wide dynamic range (90 to 120 dB), and at the same time make it possible to measure frequency with the analyzer at counter accuracy. An automatic tracking preselector is available for the microwave tuning section; it uses harmonic mixing. This tracking filter enhances an analyzer of the harmonic tuning type by virtually eliminating multiple, image, and spurious responses. In addition it decreases the harmonic and intermodulation distortion of the analyzer, giving it greater distortion-free dynamic range and allowing it to look at larger signals. The last page of this issue gives major specifications on the whole variety of available modules.



Cover: *The Hewlett-Packard Journal begins its 23rd year of publication with a new look. The redesign is the work of art director Arvid Danielson. New, also, are additions to the HP spectrum analyzer family, affecting both ends of the frequency scale, from 20 Hz*

(new audio tuning section in the foreground) to microwaves (new preselector on top of the instrument).

In this Issue:

A Fully Calibrated, Solid State Microwave Spectrum Analyzer, by Richard C. Keiter..... page 4

Tracking Generators, by John Page..... page 10

A Low Frequency Spectrum Analyzer, by Irving H. Hawley, Jr. page 14

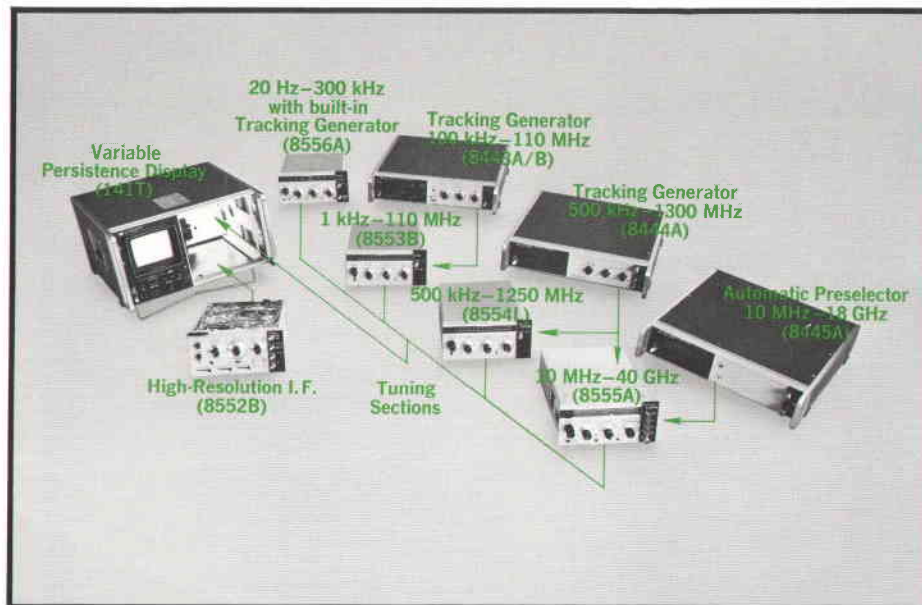

Hewlett-Packard
Spectrum Analyzer Family

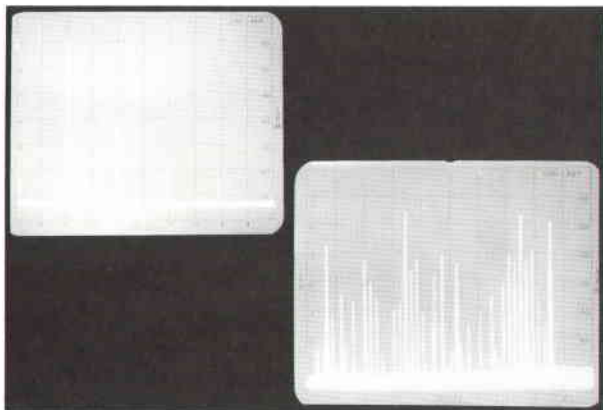

Power and Distortion Measurements

Not only is the analyzer a million times more sensitive than a power meter, it also measures power at the fundamental frequency. At the same time it shows the power in each harmonic, thus measuring harmonic distortion. Here the fundamental is a 20-MHz signal at -10 dBm (the top graticule line is 0 dBm). Second and third harmonics are seen at -43 dBm and -56 dBm. Scan is 0 to 100 MHz.

Selective Frequency and Voltage

Photo shows the FM broadcast spectrum in Palo Alto, California. The analyzer simultaneously measures them all, both in amplitude and frequency, easily distinguishing small signals surrounded by others 60 dB (1,000,000 times) larger.

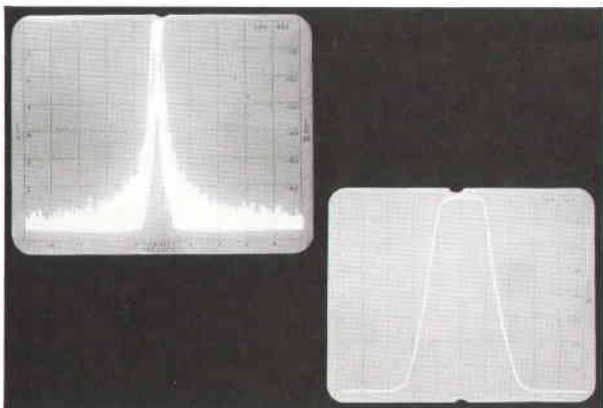

Signal Purity

An ideal oscillator would put out a perfectly clean signal, i.e., a single vertical line on the analyzer. Real signals show close-in noise, residual FM, and distortion products. This 1000 MHz signal (center) is shown to have major sideband skirts 55 dB down and about 5 kHz from the center (scale is 5 kHz per division). Residual FM is a back-and-forth motion, whose peak-to-peak value is about 2 kHz. The stability thus is 2 parts in 10^6 .

Swept Frequency Measurement

A swept measurement system of superior character is formed by combining analyzer and tracking generator. Here the amplitude response of a crystal filter is easily shown over a range exceeding 70 dB. Center frequency is 278 kHz, horizontal calibration is 50 Hz/division, vertical response 10 dB/division. 3 dB bandwidth is seen to be 85 Hz.

Analizers Combine Expertise At Both Wide and Narrow Views

Each of the four tuning sections will dual as either a wide-band or a narrowband analyzer. That is, it can look at almost all of its tuning range at once, and when desired it can then

zoom in and display a very narrow part of the spectrum with precision. It has been common for spectrum analyzers to be specialized either on the precise, narrow view or on the broad look. The new generation of HP analyzers do both with equal facility.

A Fully Calibrated, Solid State Microwave Spectrum Analyzer

Microwave spectrum analysis with performance advantages previously associated only with lower frequency instruments.

By Richard C. Keiter

A NEW MICROWAVE SPECTRUM ANALYZER PLUG-IN (HP Model 8555A) operates over the frequency range 0.01 to 40 GHz. Some of its capabilities are:

- Absolute amplitude calibration to 18 GHz
- 0.01-to-18 GHz frequency range without accessories (to 40 GHz with external mixer)
- Automatic frequency stabilization
- Simplified signal identifier

A companion Automatic Preselector (Model 8445A) clarifies displays for complicated spectrums and improves dynamic range. The preselector is a separate self-contained unit; the microwave analyzer can be used with or without it.

Uses Harmonic Mixing

The 8555A microcircuit input mixer was designed specifically to optimize harmonic mixing. By using harmonic mixing, the analyzer operates over a very wide range of frequencies with a single octave tunable local oscillator. The equation $F_{SIG} = NF_{LO} \pm IF$ serves to clarify harmonic mixing. To receive an 18-GHz signal, the combination of 4th harmonic of the LO tuned to 4 GHz, plus the IF of 2 GHz (actually 2.05 GHz) yields 18 GHz. This response is called a 4+ response, since the harmonic number, N, is 4, and the selected sign is +.

The Block Diagram

From the block diagram (Fig. 1) it is seen that three conversions translate the signal to 50 MHz. The signal is then delivered to the 8552A/B IF section where it is converted to 3 MHz and processed

for the display. The 8555A has 14 overlapping bands with frequency scales displayed by a rotating dial drum. Eight of these bands provide operation from 0.01 to 18 GHz using LO harmonic numbers 1 to 4 and a 2.05 GHz IF. Four of the bands cover the range 12.4 to 40 GHz using harmonics 6 and 10 and a 2.05 GHz IF. When switched to one of these latter bands, the analyzer must be used with an external wave guide mixer (HP 11517A). This mixer is connected to a BNC connector on the 8555A front panel. The remaining 2 bands cover 1.5 to 4.6 GHz using fundamental mixing and a 0.55-GHz IF. The IF change is accomplished simply by bypassing the second converter as shown on the block diagram. This is necessary for coverage around 2.05 GHz, as signal inputs near the IF will pass through the input without conversion and cause the display base line to lift.

Scan Width Controls

The first local oscillator is a YIG tuned transistor oscillator¹ that can be tuned electrically from 1.8 to 4.2 GHz. Saw-tooth sweep from the IF section is applied through the scan width attenuator to produce scans ranging from 20 kHz to 2 GHz in a 1, 2, 5 sequence. The sweep signal must also be attenuated by an amount determined by the band selected. For example, when the 8-to-14 GHz band is selected, the third local oscillator harmonic is used and sweep must be attenuated by $\frac{1}{3}$. The $1/N$ attenuator is operated electrically by a 5-bit code generated by a simple shaft encoder on the end of the dial drum. All band-switching operations are accomplished by this code.

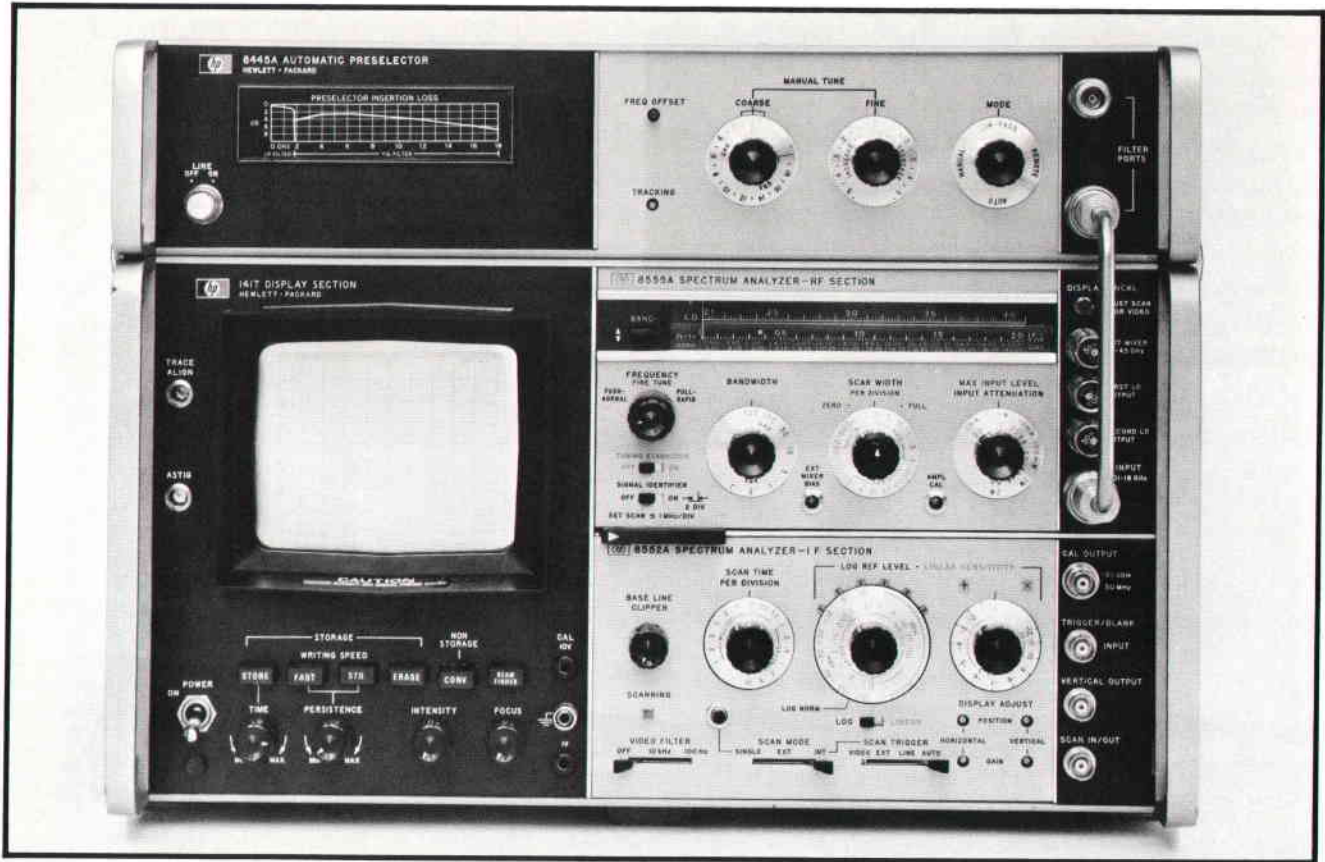

The scan width and the 1/N attenuator can be overridden by the scan mode switch. In the ZERO position, the analyzer becomes a fixed-tuned receiver (Fig. 2). In this mode, the analyzer can be

used to observe a modulation envelope. The IF section sweep trigger circuitry has a video trigger mode so the horizontal sweep can be synchronized to the time domain picture of the modulation envelope.

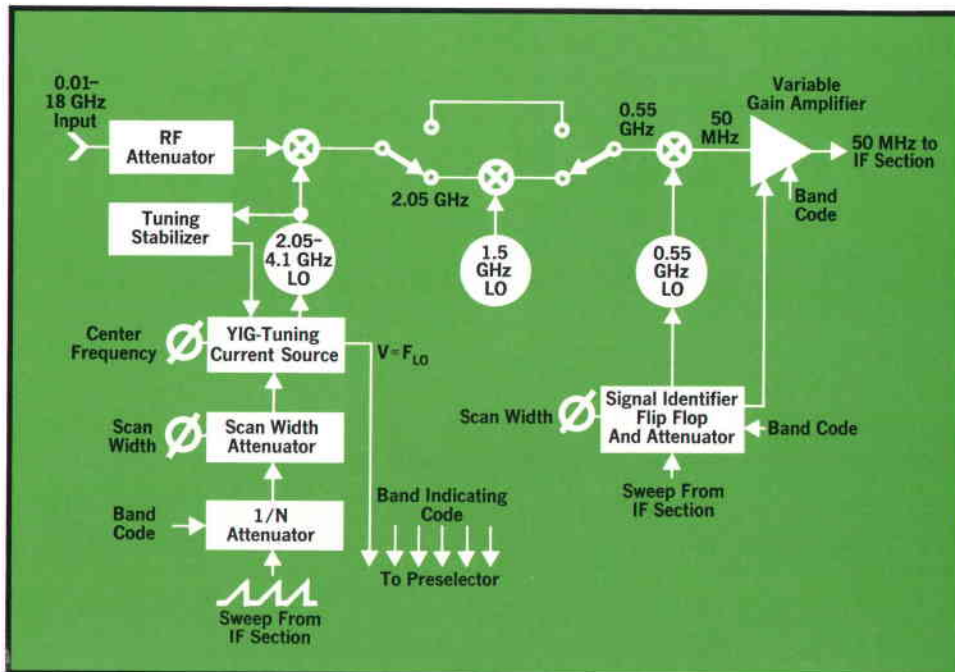

Fig. 1. Block diagram, HP Model 8555A Microwave Spectrum Analyzer plug-in.

lope. This mode is also useful to observe FM by slope detection on the filter skirt. In the FULL position, the YIG oscillator sweeps 2.05 to 4.05 GHz regardless of center frequency setting. In this mode, the center frequency knob moves a marker along the base line of the display. This is useful to 'zoom in' on detail in the display. The marker, when placed on a signal, will position the signal in the center of the display after the scan mode is switched back to PER DIVISION. The FULL mode will deliver usable scan widths up to 8 GHz when the preselector is used.

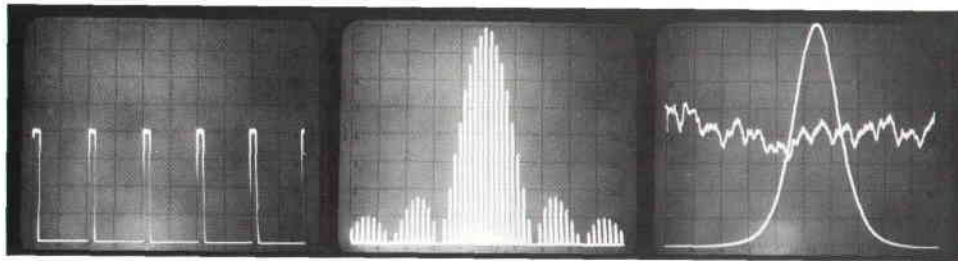

Fig. 2. Pulse-modulated 2-GHz signal viewed in the time domain.

Same signal viewed in the frequency domain illustrates resolution capability. The vertical lines are actually spectral lines spaced 1 kHz.

FM noise of a 2.6-GHz transistor oscillator using slope detection. The noise trace was made with zero scan and 3-kHz bandwidth. Then a clean signal was viewed on 3-kHz bandwidth with a 2-kHz/div scan. The slope of the skirt is 300 Hz/div, so the FM noise is approximately 600 Hz peak-to-peak.

Signal Identifier

When the preselector is not in use a single unknown signal will be displayed on each band. The amplitude, frequency, and scan width calibration will be wrong unless the proper band is selected. The proper band can be selected rapidly by turning on the SIGNAL IDENTIFIER switch (Fig 3) causing the signal to split into two responses of differing amplitude. The band is then repeatedly changed until the two responses are spaced two divisions apart with the smaller on the left. Once this is accomplished, the analyzer is on the proper band.

The mechanism for signal identification is that sweep is multiplied by N on harmonic mixing bands. When the SIGNAL IDENTIFIER switch is on, the IF is shifted from its nominal frequency, on every other scan, by twice the selected PER DIVISION scan width. This will displace the signal two divisions if the SCAN WIDTH calibration is correct. The SCAN WIDTH calibration will be correct only if a band with the correct harmonic number is selected. There are two bands per harmonic number due to the two possible mixing side bands, since $F_{SIG} = NF_{LO} \pm IF$. When a + band is selected, the IF is shifted upward and the IF gain reduced on alternate sweeps. If the analyzer is indeed receiving a + response, the shifted and attenuated response will be to the left of the un-

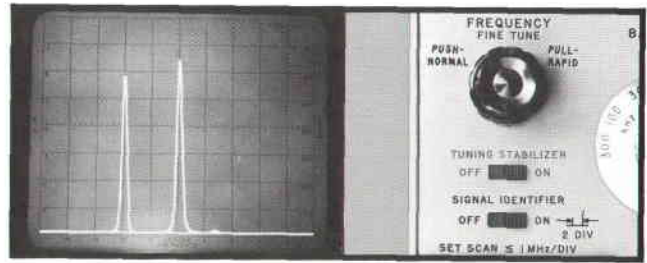

Fig. 3. When the signal identifier is switched on, the signal appears to split in two. The bands are switched until this image is obtained.

disturbed response. The shift will be to the right if observing a - response on a + band or vice versa. Fortunately, the user need not remember this theory, nor even the proper image, as it is engraved on the front panel. He needs only to switch bands until the proper image is obtained.

Completely Automatic Tuning Stabilizer

At narrow scan widths and bandwidths, the noise and drift of the first local oscillator frequency is excessive. For this reason, an automatic frequency control system is used (Fig. 4). It locks the first LO to a harmonic of a 1-MHz quartz oscillator. The 2-to-4 GHz signal is sampled at the 1-MHz rate in a thin film microcircuit sampler. The output of the sampler is a low-frequency signal resulting from the difference between the LO frequency and the nearest 1-MHz harmonic. This low frequency signal drives a discriminator with a center frequency of 240 kHz. The voltage out of the discriminator is fed back to the LO to force the sampler output to be 240 kHz. This system greatly reduces the local oscillator's drift and FM, as the LO frequency is

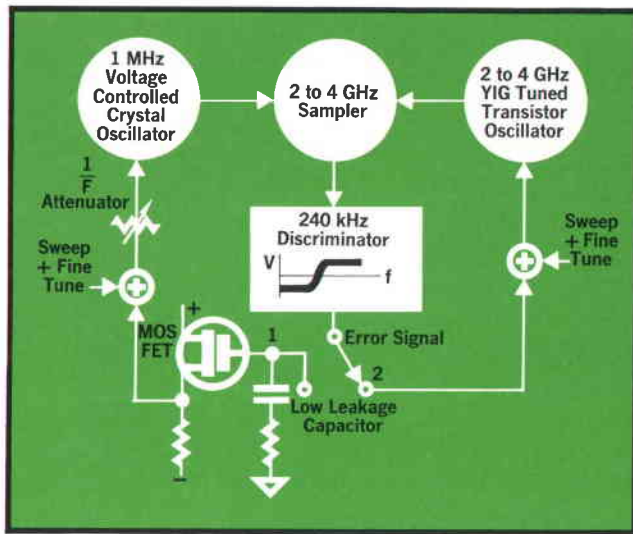

Fig. 4. Block diagram of tuning stabilizer system.

now equal to a harmonic of the stable 1 MHz oscillator minus 240 kHz.

This stabilizer system is actuated automatically as the scan width is reduced from 200 kHz per division to 100 kHz per division. Initial lock up is complicated by the fact that the LO would, in general, have to change frequency to get to a lock point $[n(1 \text{ MHz}) - 240 \text{ kHz}]$. This would cause the displayed signals to shift, possibly completely off screen. To correct this problem, a lock point is brought to the LO frequency before the LO is locked. This is done by initially reversing the function of the stabilizer system. The stable 1-MHz oscillator is first locked to the unstable local oscillator. The voltage necessary to make a lock point coincide with the LO frequency is stored on a low leakage capacitor. The switch is then put to position 2, locking the local oscillator with no motion. The stabilization process is completely automatic, requiring none of the manual operations of previous microwave analyzers.

Absolute Amplitude Calibration

The 8555A design started with the goal of achieving absolute amplitude calibration to 18 GHz. Now the user can read the amplitude of signals directly off the CRT screen, expediting many measurements. Without it the analyzer response would have to be separately measured and recorded at all frequencies of interest. This gets very cumbersome if one is working with a heterodyne system involving widely different IF, LO and input frequencies. It is also convenient to measure the response of a

filter, or amplifier or oscillator output, without first having to 'grease pencil' the frequency response of the analyzer.

Absolute amplitude calibration requires the input mixer to have flat (or at least predictable) frequency response (Fig. 5). The conversion loss of this mixer changes as a function of the LO harmonic used. The conversion loss also exhibits a gentle roll-off at the higher frequencies due to diode capacitance and bonding inductance. These effects are corrected by a variable-gain amplifier at the 50-MHz IF. The amount of compensation needed for each band is set by selected resistors mounted on a small plug-in PC board. This board is matched to the mixer so that, should the mixer be replaced, the board is also replaced to maintain calibration. The mixer has uniform frequency response in the sense that it is free of the large 'roller coaster' response variations commonly exhibited by microwave mixers. Variations of this sort are virtually impossible to compensate. Non-flat response is particularly prevalent in harmonic mixers on high harmonics because conversion loss is a sensitive function of diode conduction angle (the portion of one LO period when the diode is conducting). The 8555A optimizes diode bias for each harmonic number and maintains constant local oscillator drive to control the conduction angle tightly.

The Need for Preselection

When receiving a signal on a particular harmonic, the analyzer will also respond to signals detected on other local oscillator harmonics. For instance, with the LO at 4 GHz, a 14-GHz signal could be observed on the screen along with an 18-GHz signal due to the 3+ or 4- response. When the local oscillator is swept over its 2-to-4 GHz range, any signal between 0.01 and 18 GHz will appear somewhere on the screen. This is useful to locate troublesome high-frequency signals such as undesired oscillations in transistor circuitry. However, when viewing a complicated wideband spectrum this behavior is undesirable, as the display is difficult to interpret. This situation is considerably improved by using the 8445A Automatic Preselector (Fig. 6). The preselector is a tunable bandpass filter which tracks the analyzer signal frequency automatically. Thus, when the analyzer is receiving 18 GHz on the 4+ band, the 14 GHz signal is in the stop band of the filter and is attenuated. The preselector consists of

a 2 pole, 1.8-to-18 GHz Yttrium Iron Garnet (YIG) filter and the necessary control electronics to track this filter to the 8555A signal frequency. A 1.8-GHz,

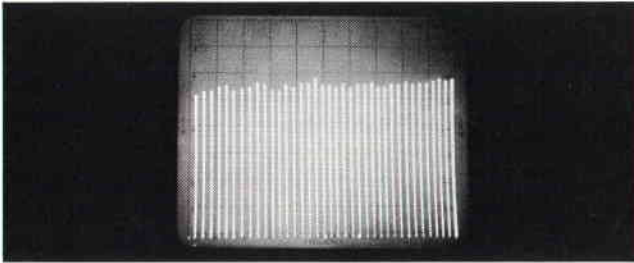

Fig. 5. Scanning 4 to 6 GHz with vertical scale 2 dB/div, this photo displays flat response of 8555A. A leveled signal is slowly swept from 4 to 6 GHz while the analyzer is sweeping 40 times faster. Some of the variation is due to the sweeper and some to the analyzer. Scan width 200 MHz/div, bandwidth 300 kHz. Log reference level (topmost line) 0 dBm.

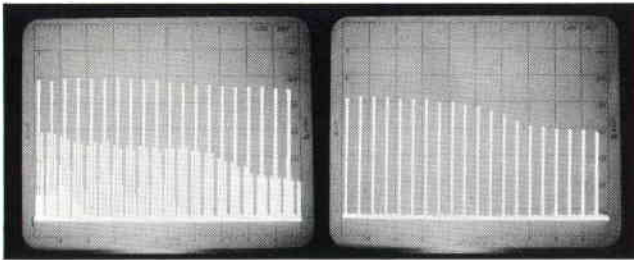

Fig. 6. 100-MHz pulse train viewed on 2.6-4.6 GHz band without preselector. Display is obscured by stronger responses at low frequencies.

Same pulse train viewed with preselector. Both photos, scan width 200 MHz/div, bandwidth 300 kHz, log reference level -13 dBm.

17-element low-pass filter is also provided for operation on the 0.01-to-2 GHz band. An option exists that eliminates the low pass filter and associated coaxial relays to yield lower insertion loss and cost for the range 1.8 to 18 GHz.

Tracking

The 5-bit band-indicating code generated by the 8555A and a voltage proportional to the first local oscillator frequency are connected via a rear panel cable to the preselector. These signals electronically solve the equation $F_{SIG} = NF_{LO} \pm IF$. The solution of the equation determines the current in the YIG filter magnet so the filter frequency tracks the analyzer frequency.

The insertion loss of each preselector is measured and plotted on a small graph attached to the front panel. This allows absolute level measurements to be made when using the preselector. When making level measurements, the front panel offset control

should be rotated to insure that the signal is peaked in the filter passband. Small tracking errors can produce errors of a few dB at the higher frequencies.

Performance Advantages

As previously mentioned, the preselector is advantageous when viewing a complicated, wideband microwave spectrum. The harmonic mixing analyzer, alone, superimposes each band on top of the others. This effect is seen in Fig. 6 which shows the analyzer's response to a 100 MHz pulse train in a 'before and after' sequence.

The preselector also yields large improvements in distortion performance of the system (Fig. 7). It is common to use a two-tone test to characterize third-order intermodulation distortion of a device under test. If the spacing of the test signals is comparable to or greater than the YIG filter bandwidth, the test signals will be attenuated by the preselector at the instant the system is sweeping through the distortion response frequencies. Distortion in the analyzer system is virtually eliminated for spacings greater than 60 MHz. Similar improvements are obtained for testing harmonic distortion.

The YIG Filter

The heart of the preselector is the YIG filter. Since it is desirable to maintain absolute amplitude calibration when using the preselector, the design objectives for the filter were severe. Notches in the passband due to magnetostatic modes can not be tolerated. The filter must not exhibit excessive passband ripple due to improper coupling or mis-tracking spheres. The frequency versus current linearity must be excellent to insure tracking to the 8555A.

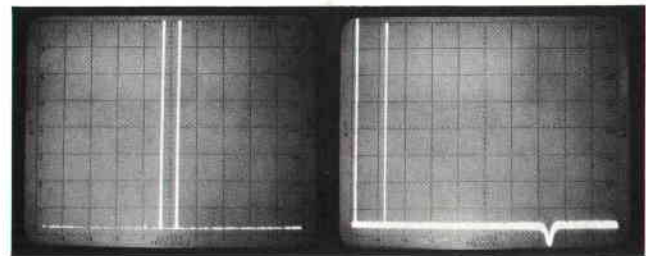

Fig. 7. Intermodulation Performance Using Preselector
Two signals, 3.8 and 3.86 GHz. Scan width 100 MHz/div, bandwidth 300 kHz, log ref level 0 dBm, input attenuation 10 dB, band 2.6 to 4.6 GHz.

Harmonic Distortion Performance Using Preselector
Signal at 2.5 GHz, marker at 5 GHz. Full scan 4 GHz, bandwidth 300 kHz, log ref level 0 dBm, input attenuation 10 dB, band 2 to 6 GHz.

Thin film substrates with gold metallization were used to hold the YIG spheres and form the coupling structure. This technique provides repeatability and was designed to minimize excitation of magneto-static modes. The structure is mounted on an adjustable gimbal to adjust the direction of the magnetic field in the spheres precisely, yielding further improvement in mode reduction.

Stand-Alone Operation As A Bandpass Filter

It was mentioned earlier that it is advantageous to have the preselector as a unit separate from the analyzer. Sensitivity and flatness advantages are to be had when bypassing the preselector, but also the separate construction makes the 8445A a 'stand alone' instrument. An option is provided that adds three knobs to the front panel: coarse frequency, fine frequency, and a mode switch. With these knobs the instrument can be used as a manually settable bandpass filter from 1.8 to 18 GHz.

In addition, the preselector center frequency can be selected with an external voltage (+1V per GHz) supplied to a BNC connector on the rear of the instrument. Special techniques must be employed to use this remote connector, as the filter will exhibit up to 80 MHz of hysteresis. When used as a preselector, this hysteresis is reduced by driving the filter 4 GHz below its sweep start frequency before every sweep. This assures that the desired frequency is always approached from the low side. The same technique can be used at the remote connector.

Acknowledgments

The 8555A project was blessed with the efforts of many very talented engineers. John Lamy did the microcircuit design of the broadband input mixer and the S-band sampler for the tuning stabilizer system. Although this kept him busy most of his waking hours, he was also burdened with the design of the 2.05 GHz-to-0.55 GHz converter assembly. John Nidecker designed the front panel mechanism as a labor of love. His initial designs were so sophisticated we thought we might do away with the user and have the analyzer turn its own knobs! Jack Magri, along with John Nidecker, is responsible for the handsome panel appearance of this analyzer and the other plug-in analyzers. Larry Nutting designed the signal identifier electronics, the power supply regulators, and the front panel switching. Larry also worked with production group during introduction. Bob DeVries had the task of fitting

this complex instrument into the plug-in box while maintaining Hewlett-Packard's standards for serviceability. He frequently borrowed John Nidecker's shoehorn. Larry Martin, a fast man with a Kar-naugh map, volunteered to do the band decoding logic. Bill Dowlin, the production engineer for the 8555A, Larry Nutting, and the Microwave Sprint group are to be commended for a very well organized and troublefree introduction phase. John Hallyburton and Bill Whitney wrote a very fine service manual.

The 8445A Automatic Preselector project was led by Pete Szente. Pete's initial task was to develop a YIG filter with sufficient performance to function as a preselector for the broadband 8555A. When it was clear this could be done, the project was started. Pete Bice designed the electronics to tune the filter. Pete Bice also programmed an HP 9100 Calculator and 9125 Plotter to make the calibration charts used on the preselector. Ron Trelle was responsible for the product design and the YIG filter magnet and body design. Ron also worked closely with Microelectronics to transfer the process for machining the very precise sapphire substrates that hold the YIG spheres. 

Reference

1. Dupre, John J., '1.8 to 4.2 GHz YIG Tuned Transistor Oscillator with a Wide Band Buffer Amplifier,' GMTT Microwave Symposium, 1969, pp. 432-438.



Richard C. Keiter

Rit Keiter is section manager for microwave spectrum analyzers. He's been with HP since 1965, when he graduated from the University of Colorado with a BS degree in electrical engineering. He also holds an MSEE degree from Stanford University earned on a part-time basis and received in 1968. Rit's contributions at HP are in power measurement and spectrum analysis instruments, the latest being the 8555A. In his spare time he likes to fly and to work on engines, which may mean that if anything goes wrong up there, he has only himself to blame.

Tracking Generators

Tracking generators, working with spectrum analyzers, expand measuring ability.

By John Page

SPECTRUM ANALYZERS make versatile response indicators for swept frequency measurements on electrical networks such as filters, amplifiers, and mixers. Good flatness, sensitivity, and frequency resolution are important characteristics which the spectrum analyzer provides. For many measurements, a general-purpose signal generator is the stimulus for the network being measured. A sweeper allows a more rapid measurement over broader frequency ranges but for clear presentation it must be swept at a slower rate than the spectrum analyzer.

Most network measurements, such as frequency response of filters or amplifiers or return loss measurements, are made with the stimulus frequency passing unchanged through the network. For these measurements, convenience and accuracy are enhanced if a *tracking generator* is used as the signal stimulus. A tracking generator is one which is slaved to the tuning of the spectrum analyzer so the generator's output frequency is always centered in the passband of the spectrum analyzer. The tracking process yields a number of significant advantages over other frequency-response measurement techniques; moreover, it greatly improves the frequency accuracy of the basic spectrum analyzer when a frequency counter is added to the instrument array.

The most obvious advantage of the tracking generator for frequency response measurements is the increased clarity of the displayed information. The measurement is continuous, and no information is lost due to point-by-point presentation. See Fig. 1.

Distortion has caused an additional undesired response in the measurement made with a sweeper in Fig. 1. In this case the distortion is created in the spectrum analyzer by the large signal present at the input when the sweeper output frequency is in the passband of the device under test. Distortion in the generator can also be a problem, especially if a

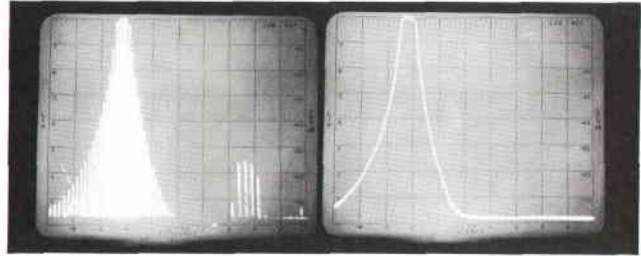

Fig. 1. Frequency response of 50-MHz bandpass filter. View at left is with sweeper source, at right with tracking generator source.

broadband detector is used instead of a spectrum analyzer. When testing devices where the fundamental is attenuated and the harmonics are not, such as band stop or high pass filters, distortion will limit the achievable measurement range. Distortion, whether in the generator or the spectrum analyzer, is not a problem when a tracking generator is used. With the tracking generator it is permissible to over-drive the spectrum analyzer greatly, without creating distortion products. Response measurements can be made over an amplitude range extending from the analyzer's maximum permissible signal level, usually about +10 dBm, to the noise level, about -120 dBm or less, giving a total measurement range greater than 130 dB.

The residual FM of the signal source determines the frequency resolution of the swept measurement. Measuring very narrow-band devices requires a very stable source. The tracking generator, since it is synchronized to the spectrum analyzer, has the same residual FM as the local oscillator in the spectrum analyzer. The spectrum analyzer uses frequency stabilization techniques to get sufficiently low residual FM for use with narrow IF bandwidths. This same low FM in the tracking generator signal will allow measurements of filters with equally narrow bandwidths.

Tracking generators covering the frequency range 20 Hz to 1300 MHz are available for the

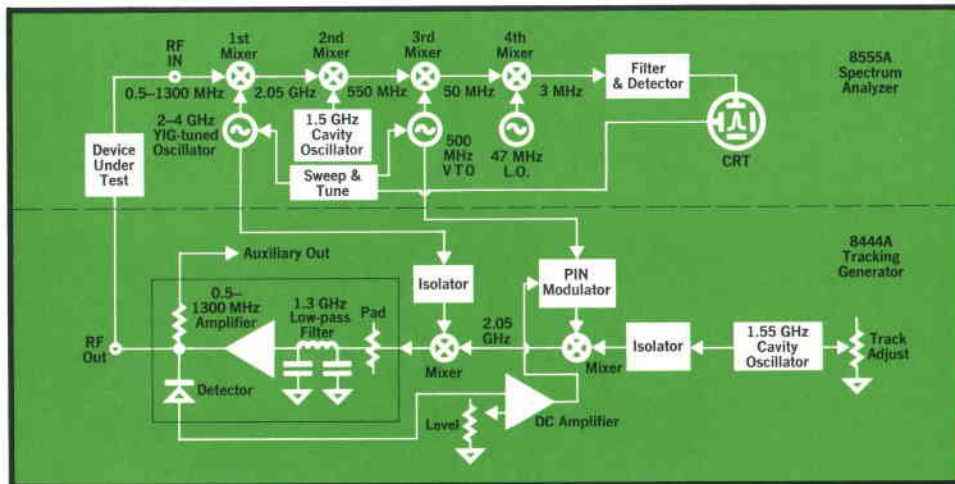

Fig. 2. Block diagram shows how 8444A Tracking Generator interacts with 8555A Microwave Spectrum Analyzer.

HP spectrum analyzer family. A 20 Hz to 300 kHz tracking generator is built into the 8556A Audio Spectrum Analyzer, described in this issue. The 0.1 to 110 MHz frequency range is covered by the 8443 Tracking Generator-Counter which works with the 110-MHz Model 8553 Spectrum Analyzer. A new tracking generator covering the frequency range from 0.5 to 1300 MHz, Model 8444A, will function either with the Model 8554L Spectrum Analyzer (0.5 MHz to 1250 MHz) or with the 8555A Spectrum Analyzer in the range 10 MHz to 1300 MHz. Figure 2 shows how the generator combines with the 8555A. A cavity oscillator at the intermediate frequency of the tracking generator provides good tracking capability for spectrum analyzer IF bandwidths down to 10 kHz. This oscillator has residual FM low enough to allow measurement of filters or networks with 1-kHz bandwidth or less.

Since the tracking generator is always tracking the spectrum analyzer, measuring the tracking generator frequency will precisely identify the frequency of responses seen on the spectrum analyzer, either external signals or points on frequency response displays. This is best done by stopping the

scan on the signal of interest. There is a manual scan control on the 8552B IF unit and on the 8444 Tracking Generator for this purpose. The measurement is made by connecting a frequency counter to the output of the tracking generator. Fig. 3.

Acknowledgments

The 8444 Tracking Generator development team was led by Tom Grisell. Robert Macy and Frank Rahe assisted Tom with the circuit design. Dieter Scherer designed the output amplifier. Mike Ammirato was responsible for the mechanical design and packaging.

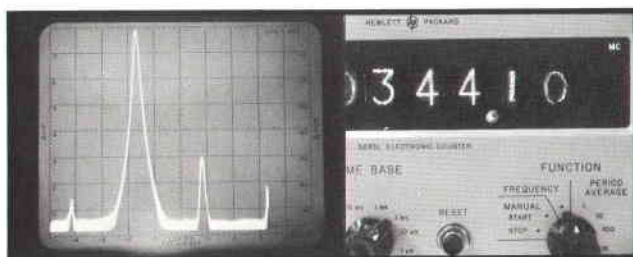

Fig. 3. Frequency of any signal on the screen can be measured accurately by counting the frequency of the tracking generator when it is synchronized with the signal of interest.



John R. Page, Jr.

John Page, section manager for RF spectrum analyzers and tracking generators, began his HP career nearly nine years ago as a circuit designer. As designer, project manager, and section manager, he's had a hand in the development of nearly a dozen successful instruments. John received his BS degree in electrical engineering from Stanford University in 1959, then served from 1960-1961 as an officer on the aircraft carrier USS Coral Sea. Back at Stanford he received his MS degree in electrical engineering in 1962.

A Low Frequency Spectrum Analyzer

Fully calibrated spectrum analysis now is extended downwards to 20 Hz.

By Irving H. Hawley, Jr.

THREE YEARS AGO fully calibrated spectrum analysis first became a routine reality with the introduction of the HP Model 8553L/8552A Spectrum Analyzer operating in the range of 1 kHz to 110 MHz. Recently, with the 8556A Low Frequency Spectrum Analyzer tuning section, this capability has been extended downwards to 20 Hz. In the range 1 kHz to 300 kHz, where its frequency coverage overlaps that of the earlier unit, the 8556A offers the advantages of high impedance input, a built-in tracking generator, 20-kHz crystal markers, wider dynamic range, and the option of balanced input.

8556A Uses Existing IF Sections

Like the rest of the HP plug-in spectrum analyzer family, the 8556A uses the 8552A or 8552B IF Section to process the signals sent out of the tuning section at an intermediate frequency of 50 MHz. Fig. 2 is a simplified block diagram of the complete system. When used with the 8552B, the 8556A forms a system with resolution bandwidth of 10 Hz, and with a 10:1 shape factor (60 dB to 3 dB), which measures signals as low as 20 Hz. (The older 8552A yields a resolution bandwidth of 50 Hz and limits the low frequency response to 100 Hz, but it still provides full measurement capability for higher frequencies.)

Isolated Front End Eliminates Ground Loops, Provides 1 Megohm Input

The front end of the 8556A, shown in Fig. 3, is isolated from chassis ground. Isolation eliminates the possibility of spurious signal pickup which



Fig. 1. A new plug-in LF Section for the HP Spectrum Analyzer family to 300 kHz, features built-in tracking generator and crystal markers. A low-noise isolated front end provides high sensitivity (20 nanovolts) and freedom from ground-loop pickup. Absolute calibration in power for several impedances is provided, with an option for balanced input.

could be caused by line-related ground currents flowing in the ground connections between the analyzer and the signal source being measured. A low-noise FET preamp is used to achieve high sensitivity (better than 20 nanovolts with a 10-Hz bandwidth) and low distortion. The gain of the preamp is controlled by a front panel switch giving linear calibration in volts per division, and log calibration in dBV (dB below 1 volt), or in dBm referenced to 50 ohms or to 600 ohms. To prevent overload of the preamp and first mixer, a combination of preattenuation in front of the preamp and following post attenuation is set by an input level control. The input level control directly indicates the maximum input level tolerable at each setting,

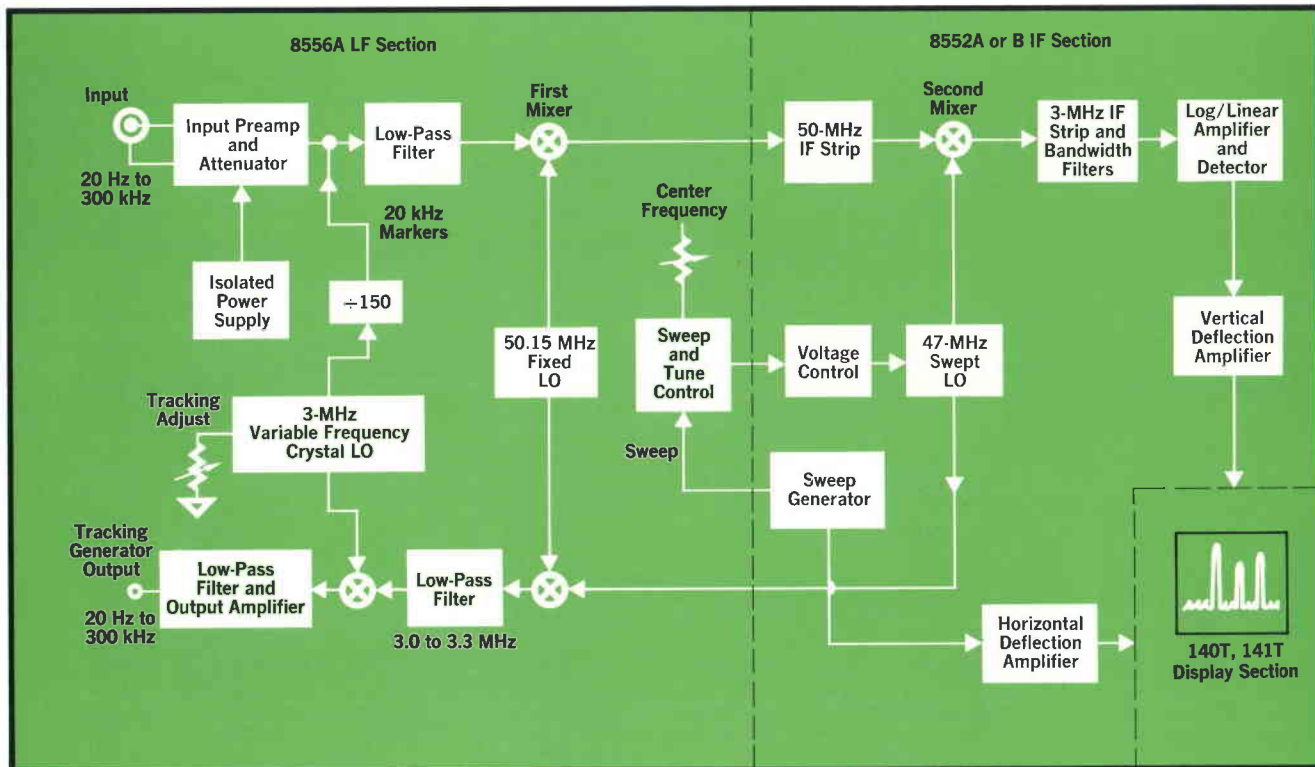

Fig. 2. The 8556A serves as a preamplifier and upconverter for the 8552. Signals are processed in the 8552 using the swept 47-MHz LO. A tracking generator in the 8556A is synthesized from the 50.15 MHz fixed LO, the 47 MHz swept LO and a variable frequency 3-MHz crystal LO, assuring stable frequency tracking between the input and tracking generator.

while maintaining a 70-dB spurious-free display. The preamp and preattenuator present an input impedance of 1 megohm, so an oscilloscope probe can be used with the analyzer with minimum loading of high impedance circuits.

Balanced Input Optional

The 8556A is available with a balanced input. Two balanced-to-unbalanced transformers are used in a converter in front of the preamp to cover the full range, 20 Hz to 300 kHz. Considerable care was required in the transformer design. The result is a balanced input with an input impedance of approximately 15 k ohms with balance (symmetry) greater than 80 dB at 60 Hz and greater than 50 dB at 300 kHz. Calibration for dBm at impedances of 135, 600, and 900 ohms is available with Option 001, and at impedances of 150, 600, and 900 ohms with Option 002.

First Mixer Design Achieves Low Distortion

Most spectrum analyzers exhibit increased distortion at low frequencies. As the first local oscillator is swept through the first intermediate fre-

quency, its signal feeds through the mixer into the IF section and produces a signal which appears at zero frequency on the display. Often this LO signal cannot be sufficiently suppressed or balanced out in the first mixer and it then overloads the following mixers and IF's, resulting in high distortion for low-frequency signals.

This problem has been solved in the 8556A. The first mixer uses a fixed local oscillator at a frequency of 50.15 MHz, much higher than the maximum input frequency of the instrument. Now the mixer can be adjusted to suppress the local oscillator by more than 90 dB and assures that even at maximum sensitivity the LO feedthrough will not overload the following mixer or IF's.

Built-In Tracking Generator and Markers

The double frequency conversion scheme used in the 8556/8552 system, with two high-frequency local oscillators, made it readily possible to include a tracking generator in the 8556. Since the tracking generator signal is synthesized from the very same local oscillators that are used to convert an input

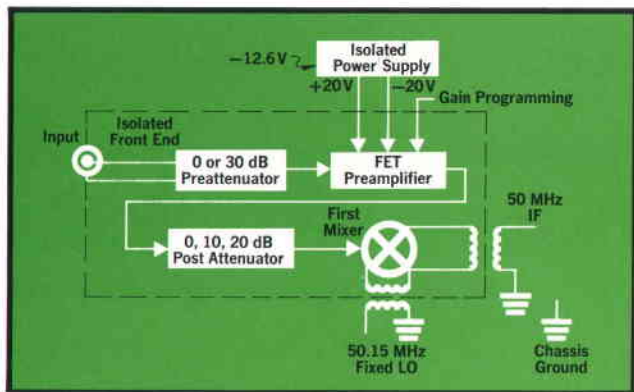

Fig. 3. Preattenuator, FET preamp, post attenuator, and first mixer are all isolated from chassis ground to prevent power line ground-loop pickup. Isolated power supply is a switching type supply, converting -12.6 V to an isolated $+20\text{ V}$ and -20 V for the preamp.

signal to the last intermediate frequency, good tracking is assured. A fine-frequency adjustment ($\pm 150\text{ Hz}$) on the 3-MHz variable frequency crystal LO sets the frequency of a reconverted tracking generator signal exactly in the center of the 3-MHz crystal-controlled last IF. The 3-MHz LO is also divided by 150 in integrated circuit dividers to produce a narrow 20-kHz pulse. This pulse may be applied to the front end of the analyzer, yielding equal-amplitude 20-kHz markers accurate to 0.01%.

The tracking generator performs several especially useful functions in this analyzer system. Of course it may be used to make frequency response measurements of active or passive networks. It is also useful to compensate an oscilloscope probe connected to the analyzer's input. While its output level is variable from 100 mV to 3 volts, a calibrated output level of 100 mV may be selected and used to calibrate the analyzer in amplitude. Accurate signal frequency measurements (within $\pm 3\text{ Hz}$) are also possible by connecting a counter to the tracking generator output and tuning to the signal of interest.

Analyzer Measures and Identifies Distortion Products

Fig. 4 illustrates the ability of the 8556A Analyzer System to sort out and identify many different frequency components. Two signals, 80 kHz and 90 kHz, were applied to an amplifier and the resulting distortion products are shown. The two test signals appear at the Log Reference Level (top graticule line). Second order intermodulation prod-

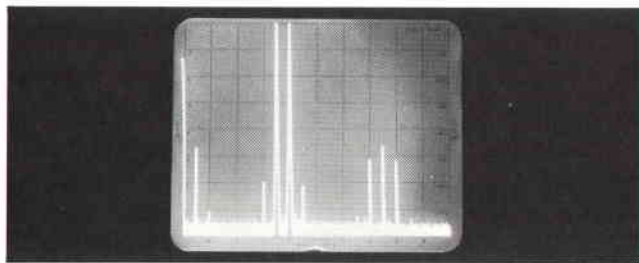

Fig. 4. Distortion products produced in an amplifier. The 80 and 90 kHz test signals are at a Log Reference Level of -20 dBV (100 mV). 20 kHz-per-division scan displays second and third order distortion products.

ucts, produced in the amplifier, appear at 10 kHz and 170 kHz and measure 46 dB down. The second harmonics of the two test signals appear 52 dB down at 160 kHz and 190 kHz. Third order intermodulation products appear 60 dB down next to the two test signals.

High Selectivity and Sensitivity Find Small Signals Next To Large Ones

The analyzer has the ability to identify and measure small signals in the presence of signals many orders of magnitude larger. Fig. 5 illustrates this. The small signal center screen is $0.3\text{ }\mu\text{V}$ (-130 dBV) at a frequency of 1,350 Hz. Approximately 150 Hz lower is a signal of 1 mV (-60 dBV). The highly selective 10-Hz bandwidth filter in the 8552B allows closely spaced signals of widely different amplitude to be resolved.

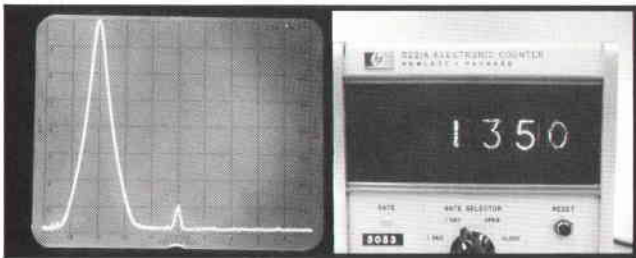

Fig. 5. A $0.3\text{ }\mu\text{V}$ (-130 dBV) signal is measured only 150 Hz away from a signal 70 dB larger. A counter connected to the tracking generator output was used to measure the frequency of the small signal.

10-Hz Bandwidth Measures Line-Related Sidebands

Signal sources which derive their power from an ac power supply may deliver signals containing modulation due to power supply hum. When used with the 8552B, the 8556 can resolve these modulation sidebands more than 60 dB down. Fig. 6 shows an oscillator at 200 kHz with 60 Hz sidebands 65 dB down. (This high resolution capabil-

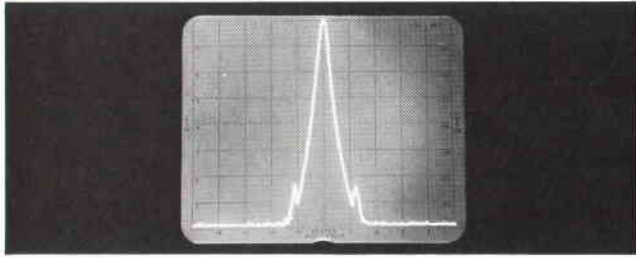

Fig. 6. 8556A (with 8552B) resolves 60-Hz sidebands more than 60 dB down. Scan width is 50 Hz per division. The spectrum analyzer itself is seen to be entirely free of line-related sidebands.

ity may be extended to 110 MHz using the 8553B/8552B Spectrum Analyzer.)

Wide Dynamic Range As A Swept Frequency Measuring System

When the analyzer and its tracking generator are used to make frequency response measurements, signal amplitudes between +10 dBV and -130 dBV may be measured, providing a measurement range of 140 dB. Even though only 70 dB of this range may be displayed at one time, amplitude displays may be 'stacked' photographically to provide frequency response measurements over a much wider range. Fig. 7 illustrates this, showing the frequency response of a 278-kHz bandpass filter over a 140-dB range. The wide scan capabilities and good flatness of the analyzer also make it useful for measurements of wideband amplifiers such as those used in newer high-fidelity audio systems.

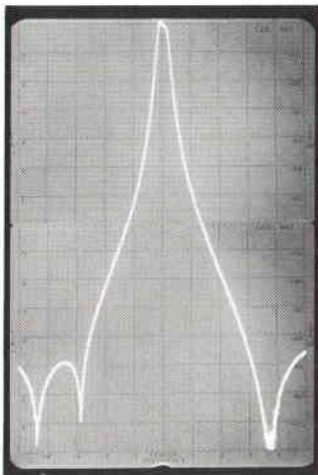

Fig. 7. Frequency response of a 278-kHz bandpass crystal filter. The upper photo was taken with a log reference level of +10 dBV and displays the upper 70 dB of the frequency response. The lower 70 dB was taken with a log reference level of -60 dBV, with the upper 70 dB of the display driven off screen. Scan width is 100 Hz/div.

Other Applications

The 8556A should find a wide variety of applications in communications, audio design and analysis, sonar, and vibration analysis. Audio measurements are simplified by the ability of the analyzer

to scan from zero to any preset frequency from 200 Hz to 200 kHz, using the 0 to 10f scan position. With a tracking generator included, the analyzer is a useful instrument for measuring both the amplitude and frequency of signals and finding the frequency response of systems.

Acknowledgments

The author would like to acknowledge the contributions of many others who worked on the 8556A analyzer system. Dee Humphreys was project leader for the 8556A during the final design stages, and he and Bob Schwehr also worked on the 8552B which provides the high-resolution IF bandwidths for the system. Jim Harmon designed the front end and tracking generator output in the 8556, and Mike Ammirato did the product design. Bruce Richards served as production engineer for the instrument and provided a great deal of assistance during its introduction into production.

References

1. Patrick J. Barrett, Robert R. Hay and Paul G. Winninghoff, 'Adding More Precision to Spectrum Analyzer Measurements,' *Hewlett-Packard Journal*, July 1970. pp. 10-16.
2. Brian D. Unter, 'Fully Calibrated Frequency Domain Measurements,' *Hewlett-Packard Journal*, August 1968.

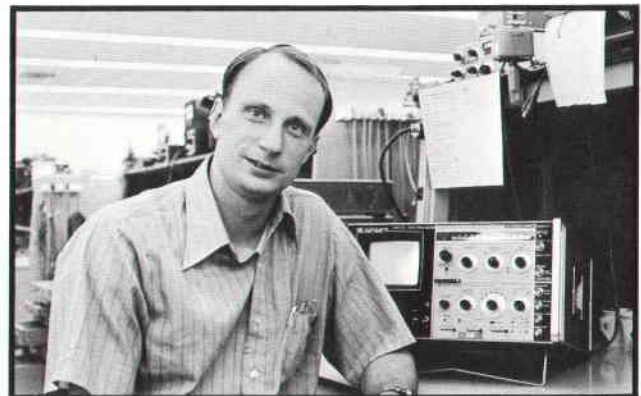

Irving H. Hawley, Jr.

As designer, production engineer, and project manager, Irv Hawley has made major contributions to HP's spectrum analyzer family. Most recently he supervised the design of the 8556A low-frequency analyzer. Irv holds a BS degree in engineering (1964) from Harvey Mudd College, and an MSEE degree (1967) from Stanford University. He serves on the IEEE Committee on Waveguide and Transmission Line Measurements and Measuring Instruments. He's been with HP for seven years.

HEWLETT-PACKARD SPECTRUM ANALYZER FAMILY MAJOR SPECIFICATIONS TUNING SECTIONS*

	8556A	8553B	8554L	8555A
FREQUENCY SPECIFICATIONS				
Tuning Range:	20 Hz to 300 kHz	1 kHz to 110 MHz	500 kHz to 1250 MHz	10 MHz to 18 GHz (with internal mixer) 12.4 GHz to 40 GHz (with external mixer)
Scan Width Range:	20 Hz/div to 20 kHz/div	20 Hz/div to 10 MHz/div	2 kHz/div to 100 MHz/div	2 kHz/div to 200 MHz/div
Frequency Accuracy:	±3 kHz ±3 Hz with counter	±1 MHz ±10 Hz with 8443A Tracking Generator/Counter	±10 MHz ±10 kHz with 8444A Tracking Generator and Counter	±N × 15 MHz where N = mixing harmonic ±10 kHz with 8444A Tracking Generator and Counter
Residual FM:	<1 Hz	<1 Hz	<300 Hz	<100 Hz to 6 GHz <300 Hz to 18 GHz
RESOLUTION SPECIFICATIONS				
3 dB Bandwidth ranges (1, 3, 10 sequence):	10 Hz to 10 kHz	10 Hz to 300 kHz	300 Hz to 300 kHz	100 Hz to 300 kHz
AMPLITUDE SPECIFICATIONS				
Measurement Range Log:	-150 dBm/dBV to +10 dBm/dBV	-137 dBm to +10 dBm	-114 dBm to +10 dBm	-122 dBm to +33 dBm
Linear Sensitivity (S + N = 2):	0.1 mV/div to 1 V/div -142 dBm (50Ω) @ 10 Hz BW -152 dBV @ 10 Hz BW	0.1 μV/div to 100 mV/div -140 dBm @ 10 Hz BW	0.1 μV/div to 20 mV/div -117 dBm @ 300 Hz BW	0.1 μV/div to 100 mV/div -125 dBm @ 100 Hz BW to 6 GHz
Distortion Products:	>70 dB down with input signal level < INPUT LEVEL control setting	>70 dB down with <-40 dBm input to mixer	>65 dB down with <-40 dBm input to mixer	>100 dB down with preselector with <0 dBm into preselector
Frequency Response:	±0.25 dB	±0.5 dB	±1.0 dB	±1.0 dB to 6 GHz
Log Amplitude Display:	±0.25 dB/dB but not more than ±1.5 dB	±0.25 dB/dB but not more than ±1.5 dB	±0.25 dB/dB but not more than ±1.5 dB	±0.25 dB/dB but not more than ±1.5 dB
Calibrator Accuracy:	-20 dBV ±0.3 dB	-30 dBm ±0.3 dB	-30 dBm ±0.3 dB	-30 dBm ±0.3 dB
SCAN SPECIFICATION				
Scan Time:	0.1 ms/div to 10 s/div	0.1 ms/div to 10 s/div	0.1 ms/div to 10 s/div	0.1 ms/div to 10 s/div

*Specifications assume tuning section used with 141T Display Section and 8552B IF Section.

TRACKING GENERATORS

	8443A*	8444A
FREQUENCY RANGE	100 kHz to 110 MHz	500 kHz to 1300 MHz
SWEPT FREQUENCY RESPONSE		
Dynamic Range:	>120 dB	>90 dB
Resolution:	10 Hz	1 kHz
Amplitude Resolution:	0.1 dB	0.1 dB
SWEEP/CW GENERATOR		
Residual FM:	<1 Hz	<100 Hz
Calibrated Output:	-120 dBm to +10 dBm	-11 dBm to 0 dBm
Frequency Accuracy:	±10 Hz	±10 kHz
Sweep Width Range:	200 Hz to 100 MHz	20 kHz to 1.25 GHz
PRECISION FREQUENCY MEASUREMENT		
Frequency Accuracy:	±10 Hz plus time base accuracy of built-in counter	±10 kHz with external counter

*Also available as 8443B without built-in counter.

MODEL 8445A PRESELECTOR

FREQUENCY RANGE:	DC to 1.8 GHz Low Pass Filter 1.8 to 18 GHz Tracking Filter
FILTER 3 dB BANDWIDTH:	30 to 45 MHz
FILTER STRUCTURE:	Two-Pole
OFFBAND REJECTION:	Typically 55 dB
PRICES:	
Display Sections	
140A Standard Persistence	\$950.00
141T Variable Persistence	\$1800.00
143S Large Screen	\$1700.00
Tuning Sections	
8556A (20 Hz to 300 kHz) Option 001, 008	\$1690.00
8553B (1 kHz to 110 MHz)	\$1900.00
8554L (500 kHz to 1250 MHz)	\$2200.00
8555A (10 MHz to 40 GHz)	\$3500.00
IF Sections	
8552A (Economy)	\$5975.00
8552B (High Resolution)	\$2200.00
Tracking Generators	
8443A (100 kHz to 110 MHz) with counter	\$2900.00
8443B (100 kHz to 110 MHz) without counter	\$3500.00
8444A (500 kHz to 1300 MHz)	\$1975.00
Preselector	
8445A (10 MHz to 18 GHz)	\$2950.00
	\$2000.00

MANUFACTURING DIVISION: MICROWAVE DIVISION
1501 Page Mill Road
Palo Alto, California 94304

HEWLETT-PACKARD JOURNAL SEPTEMBER 1971 Volume 23 - Number 1

FROM THE LABORATORIES OF HEWLETT-PACKARD COMPANY 1501 PAGE MILL ROAD, PALO ALTO, CALIFORNIA 94304 U.S.A.
Hewlett-Packard S.A., 1217 Meyrin - Geneva, Switzerland • Yokagawa-Hewlett-Packard Ltd., Shibuya-Ku, Tokyo 151 Japan
Editor: R. H. Snyder Editorial Board: R. P. Dolan, H. L. Roberts, L. D. Shergalis Art Director: Arvid A. Danielson Assistant: Mandel Jordan

HP Archive

This vintage Hewlett-Packard document was
preserved and distributed by

www.hparchive.com

Please visit us on the web!

On-line curator: John Miles, KE5FX

jmiles@pop.net

