

HEWLETT-PACKARD JOURNAL



MAY 1971

A Power-Thrifty Portable Oscilloscope

A big step forward in battery-powered scope performance — up to 75 MHz bandwidth with dual-trace operation and delayed sweep — is taken by the new 1700-series Oscilloscopes. But even without batteries, these compact factota have a lot to recommend them.

By Thomas K. Bohley, Robert E. Mast, and Donald R. Bloyer

FIELD-SERVICE OSCILLOSCOPES must meet requirements that are somewhat different from those of other oscilloscopes. Light weight and portability are obvious requirements but there are others such as provision for rack mounting, a common requisite for production test oscilloscopes, that are not so important.

Performance at the lab scope level is very often a must for field work but the lab scope's plug-in versatility is not needed. This is because field service measurement requirements are well defined and remain constant for long periods of time—the service oscilloscope is usually used for testing only one particular system or piece of equipment until the equipment is obsoleted or replaced. For this reason, the plug-in concept can be dispensed with in favor of reducing costs—low cost has special importance here because these scopes are often obtained in large quantities.

Battery operation, though not required in every instance, is desirable because it frees the test engineer from the bother of running extension cords here and there in large installations, as well as enabling operation where ac line power is simply unavailable.

With these requirements in mind, a new family of field service oscilloscopes has been designed. Three models are offered initially, the Model 1707A with dc-75 MHz response, and the Models 1700A and 1701A with dc-35 MHz response.

Since the major application for these instruments probably will be in computer and peripheral servicing, they have been designed with lab scope performance, i.e., wideband frequency response, dual-trace operation, and triggered sweeps with sweep speeds up to 10-ns/div for accurate time comparisons. The 1707A and 1701A also have delayed sweep. These instruments have a full

6 x 10 cm display for easy trace interpretation and a 22 kV CRT accelerating potential for bright display of waveforms with low repetition rates and fast risetimes.

Nevertheless, power consumption is held to a remarkably low level: 25 watts in the 75MHz version (1707A) and less than 18 watts in the 35MHz instruments (1700A and 1701A). All can operate when supplied by an optional self-contained battery pack, or by car or aircraft batteries, or by ac power lines. Each weighs but 24 pounds (without batteries) and is in a package that measures less than 11½ x 13 x 17 inches in a form factor



Cover: Dry lake bed dramatizes ability of new 1700-series Oscilloscopes, operating on optional internal battery pack, to bring lab scope performance anywhere it may be needed. Up to 75 MHz response, dual trace display, and delayed sweep can all be had where ac line power can't. And since these cool-running instruments need no fan or ventilating holes for circulating air, dusty or other hostile environments pose no special problems.

In this Issue:

A Power-Thrifty Portable Oscilloscope, by Thomas K. Bohley, Robert E. Mast, Donald R. Bloyer page 2

NBS Publishes Revised List of Physical Constants page 11

Effective Stripline Device Characterization, by George R. Kirkpatrick page 12

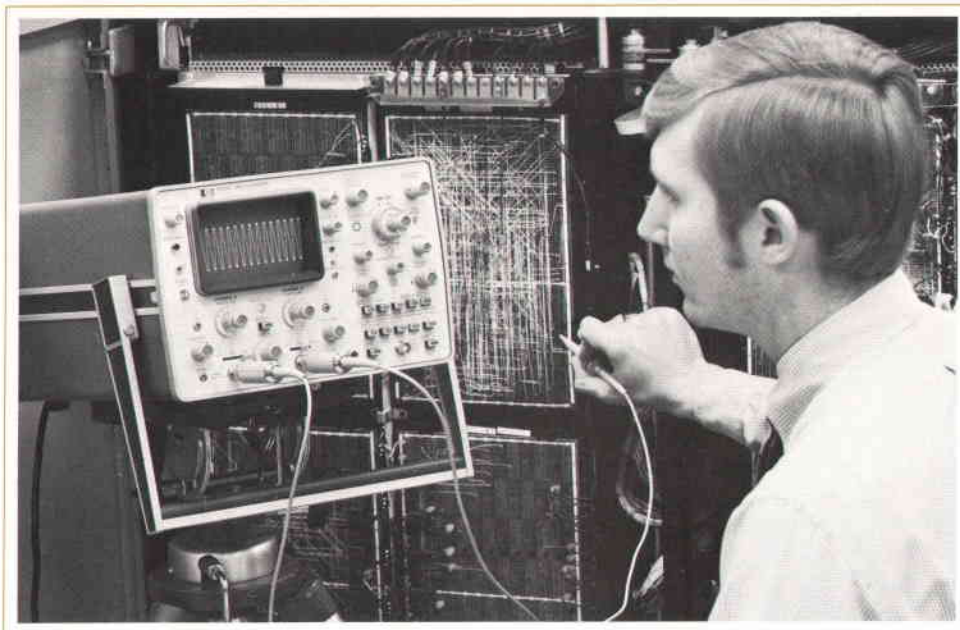

Fig. 1. Model 1701A Oscilloscope has lab scope performance with portability and independence of power line that make it useful for service work.

that has been found most convenient for carrying.

In brief, these instruments have calibrated deflection factors ranging from 10mV/div to 5V/div, 1M Ω /27pF input impedance, or 10M Ω /14pF with $\times 10$ resistive-divider probes supplied, single-sweep capability and sweep times from 10ns/div (with $\times 10$ magnifier) to 0.2s/div. Modes of operation are: either channel A or channel B alone, A and B dual-trace on alternate sweeps or chopped, A + B added algebraically, or A - B. In other words, they do just about everything that a high-quality lab scope can do, but can do it on battery power.

Non-perfidiousness

Ease of operation is a requirement for any test instrument. Despite their wide-ranging capabilities, these new oscilloscopes meet this requirement with a front-panel 'approachability' that will impress the first-time user. Particular emphasis was placed on disentangling the operation of the delayed sweep from the main sweep. Controls affecting the delayed sweep are in the vertical gray band on the front panel, clearly isolated from the main sweep controls. The sweep time switches for both sweeps are concentric, however, to allow direct reading of both sweep times at a glance.

The lack of front-panel 'clutter' is enhanced by other factors: logical grouping of controls, the use of push-buttons for two-valued functions, and a new human engineered knob and color scheme. Pushbuttons are arranged so that when all are in the 'out' position (black band showing) the scope will be in the most often used mode of operation, and a trace will be obtained easily.

New Trigger Circuit

Triggering capabilities are a major concern of any oscilloscope user. In these new scopes, off-the-shelf emitter-coupled-logic integrated circuits have replaced the traditional tunnel diodes as the trigger recognizers. This gives rock-steady operation over a wider temperature range. Stable triggering is achieved on any signal up to 75 MHz that deflects the trace 1.5 cm or, on externally-supplied triggers, that are 100mV peak-to-peak. Up to 35MHz, 1/2 cm deflection or 50mV external is all that's needed. The scopes also sweep in an AUTO mode (sweep automatically in absence of a signal, sync to any signal > 40 Hz) and have single-sweep capability.

Plug It In Anywhere

These new scopes operate on an exceptionally wide range of power sources. They run on either 115 or 230 volt power lines at line frequencies between 48 and 400 Hz. What's more, the line voltage can fluctuate *plus or minus 20%* without affecting scope operation, a useful feature especially when the instrument is supplied by portable generators.

They also operate on dc sources ranging from 11 1/2 to 36 volts, a range large enough to encompass a partially discharged 12-volt car battery on up and beyond the 28 volts commonly used in aircraft. And, a rechargeable nickel-cadmium battery pack is available as an option. The battery pack, which is completely contained inside the scope, can be put in or taken out at any time without requiring any modification of the scope's circuits.

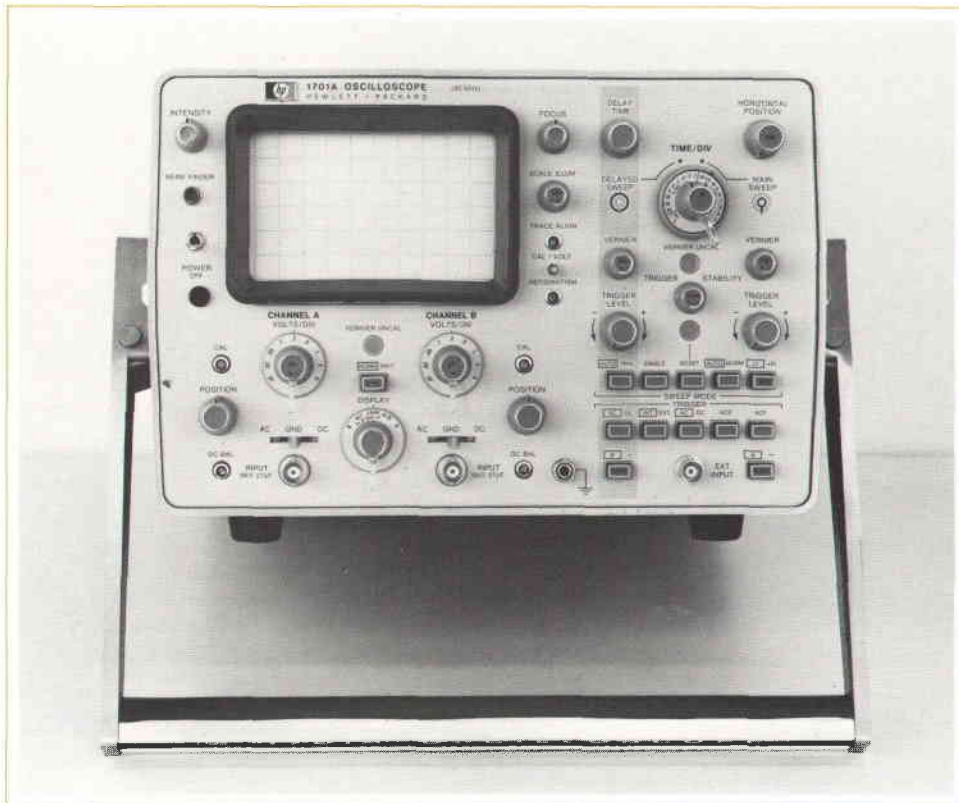

Fig. 2. Despite versatility of new Oscilloscopes (dual-trace display, delayed sweep, triggered sweeps), careful layout of controls make these instruments easy to operate. Black band around push-buttons disappears when a button is pressed, clearly showing that button is in depressed position.

Since the 35-MHz Models 1700A and 1701A require no more than 18 watts power on dc operation, they can operate up to 6 hours on the internal battery pack, and the 75-MHz Model 1707A goes 4½ hours. A warning circuit alerts the operator to a low battery condition by blinking the front-panel 'power on' lamp. The

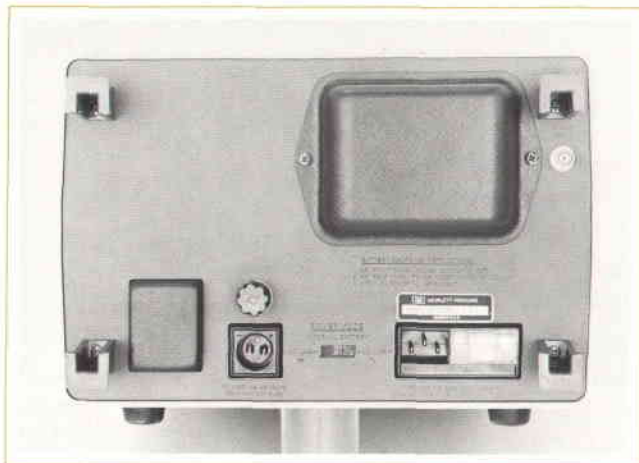

Fig. 3. Power mode switch on instrument rear panel selects source of power: ac line, dc line, optional internal battery. AC line input module conforms to new IEC international recommendations for power-line inputs. Module, winner of a 1970 WESCON industrial design award, makes certain that change from 115 to 230 V operation cannot be made unless ac line fuse is removed, making it unlikely that proper fuse change is overlooked.

batteries can be recharged in 14 hours simply by plugging the oscilloscope into an ac line.

Battery operation is advantageous in more situations than where there's a lack of ac power — for example, measurements that require the test instrument to be isolated from the powerline ground to avoid ground loops. Battery operation is also handy for 'quick look' situations where running an extension cord would be awkward.

It Started With the CRT

The uncommon performance/power-consumption ratio of these oscilloscopes is largely attributable to a new cathode-ray tube. Designed especially for this oscilloscope series, these CRT's have a more sensitive deflection factor than has previously been available in a general purpose cathode ray tube: 2V/cm vertically and 4V/cm horizontally on a 6 x 10 cm display.

The low deflection factor (i.e. high sensitivity) is the principal contributor to power economy because deflection drive circuits have been the major power consumers in oscilloscopes. The entire vertical drive output stage of the 35-MHz instruments in this new series consumes only 1.2 watts, about 10 to 20% of the deflection power of other similar oscilloscopes. As a matter of fact, the entire dual-channel vertical amplifier consumes less than 4.5 watts.

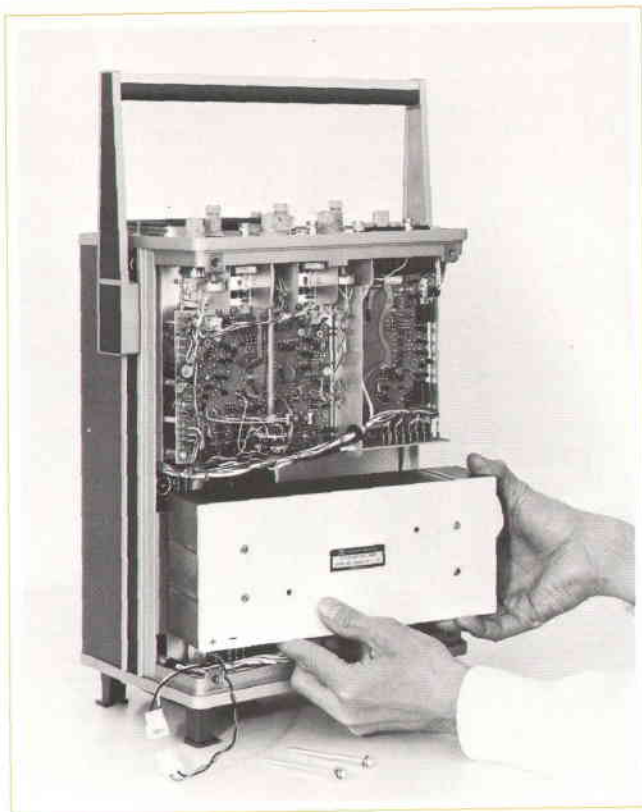

Fig. 4. *Optional battery pack mounts entirely within oscilloscope with only two screws and one connector. No modification of scope's circuits are required—battery can be added or removed at any time.*



Fig. 5. *New CRT, only 15 inches long, uses mesh electrode at exit of electron gun to create high-strength electrostatic lens that achieves 3-to-1 deflection magnification in 20 kV post-accelerator field. In addition to reducing power consumption of deflection drive circuits, new CRT uses 1-watt heater for additional power economy.*

Cool Longevity

Low power consumption is not the only benefit from the low CRT drive requirements. It was easy to design the circuits so that all components, especially semiconductors, operate at only a small fraction of their rated power even in extreme environmental conditions. The vertical output transistors do not even require heat sinks, yet they operate well within their ratings. This translates directly into high reliability.

Another benefit from the low power consumption:

no fan is needed to cool the instrument. In fact, none of these instruments even has ventilating holes, and that means less accumulation of dust and moisture inside the instrument. The absence of ventilating holes also means that short-term stability is unaffected by breezes and rapid changes in the ambient temperature.

Regulated Power Without Dissipation

Further economies in power consumption were obtained by the regulated power supply circuit. To accommodate the various input power sources, a dc-to-dc converter is used. Because the load on the power supply in non-plug-in instruments such as these is relatively constant, it was not necessary to use individual regulators on all voltages. Rather, one of the dc supply voltages is compared to a reference, and the result of that comparison controls the duty cycle of the switching circuit in the dc-to-dc converter. Because of this control, all dc supply voltages are held constant, doing away with the need for power-dissipating series regulators. At the dc input level where the converter operates with maximum efficiency (24V), a dc-to-dc conversion efficiency of 87% is achieved.

The 26¼-volt internal battery supply and external dc voltages are applied directly to the dc-to-dc converter. AC inputs are stepped down to the appropriate voltage level then rectified, smoothed and passed on to

the dc-to-dc converter. A rear-panel switch selects the power source to be used. (When operating on ac power lines power consumption is 30 volt-amperes in the 35MHz 1700A/1701A, and 50VA in the 75 MHz 1707A.)

Lab-type Delayed Sweep

The 1701A and 1707A are the first battery-powered scopes to have triggered delayed sweeps for picking out any part of the display and magnifying that part for detailed examination. To use the delayed sweep, the

(text continued on page 8)

No-Fuss Trigger Circuit

Though refined to minimize power consumption and internal adjustments, most of the sweep circuits in the Model 1700-series Oscilloscopes are conventional. The sweep generator uses the well-known Miller integrator.

But the use of integrated circuits rather than tunnel diodes as a trigger recognizer does represent a departure from recent tradition. An IC trigger circuit is advantageous because it can improve performance reliability (tunnel diodes are more sensitive to temperature changes) without increasing costs (good tunnel diodes are not inexpensive).

The fast switching speed of emitter-coupled logic IC gates can be applied here by use of positive feedback from non-inverting output to signal input. In the new trigger circuit, shown in the diagram, this is done through resistor R_F .

Switching occurs during the input signal's negative-going excursion when the signal crosses the threshold of the gate's active region, provided that all other inputs are 'low.' The output then goes from the high state to the low state in about 2ns. Unlike tunnel diodes, however, the circuit does not reset by itself when the input signal returns to the high level. This is because the feedback clamps the input in the low state. Another of the gate's inputs must move to the high level for reset to occur.

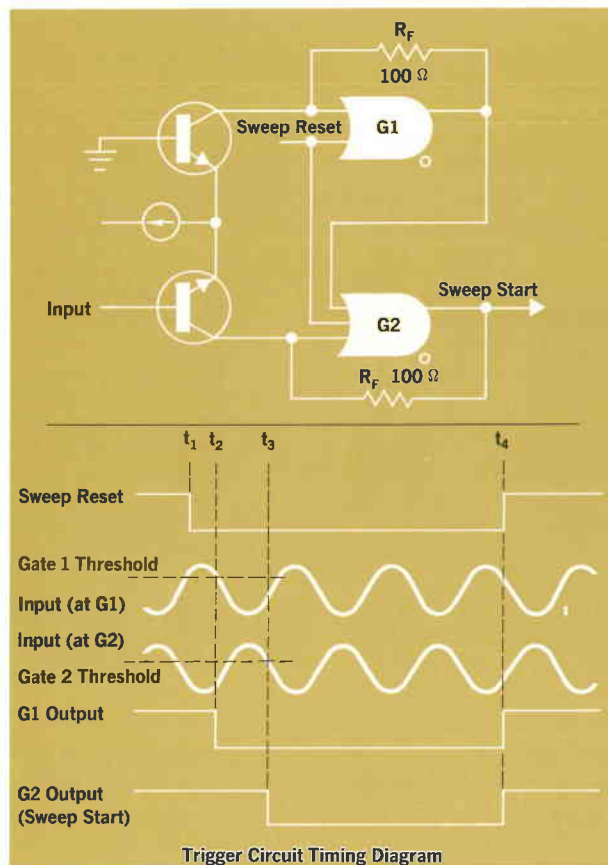

Reset is effected through a second gate. As shown in the diagram, the output of G1 is fed to G2, so anytime that G1 goes high, G2 is forced into the high state.

G1 is enabled when the sweep reset goes low (time t_1 in the timing diagram), and it will trigger when the input

signal crosses the G1 threshold (time t_2). With G1 switched, and the sweep reset low, G2 triggers when the input signal crosses its threshold (time t_3). This starts the sweep.

At the conclusion of the sweep (time t_4), the sweep reset signal goes high, and so does G1. Consequently, G2 also goes high and it is then ready for the next triggering sequence.

If the signal were already below the G1 threshold at time t_1 , G1 would trigger on the sweep reset. Such would be the case when the scope is displaying pulses, for example, where the baseline would be below the threshold.

G1 merely performs a reset and enabling function, so G2 always triggers at the same point on the input signal. The triggering level is selected by shifting the polarity and dc level of the input signal in the signal conditioning circuits ahead of the trigger circuit.

High-Efficiency Power Supply

To make possible oscilloscope operation on dc as well as ac, a dc-to-dc converter is needed. And to make possible operation on a variety of batteries and other dc sources, the converter should operate over a wide range of input voltages. At the same time, it ought to operate with high efficiency to minimize battery drain.

These goals are realized in the 1700-series Oscilloscopes with the circuit shown below. This one transistor, two-transformer circuit uses a switch to generate current ramps for transformer operation. Control of the duty cycle regulates the converter's output voltages, eliminating the need for power-consuming series regulators.

Transistor Q is the current switch. Assuming at first that Q is conducting, current then flows in the external circuit, including the primary winding of T1 and winding N1 of transformer T2. Positive feedback through winding N2 turns Q on harder.

T2 is a transformer with a saturable core so current can build up in the external circuit only as long as the core is unsaturated. When the core saturates, windings N1 and N2 decouple, opening the feedback loop. Transistor Q thereupon stops conducting, shutting off the current in the external circuit.

When the current stops, the collapsing magnetic field in T1 generates a flyback voltage that charges all the storage capacitors in the dc output lines. These capacitors supply the various dc voltages for scope operation.

The collapsing magnetic field in T2 generates a flyback voltage in winding N2 that switches on diode D in the base circuit of Q, allowing reverse current to flow in winding N2. This reverse current resets the core of T2.

The reverse current also charges capacitor C1, and when the voltage across C1 builds up sufficiently to turn on transistor Q, regeneration recommences and a new cycle starts. The base current in Q then discharges C1.

Control of the duty cycle is exercised by regulator winding N3 in T2. DC current in this winding either raises or lowers the T2 saturation level by opposing or aiding the flux built up by current in winding N1. The regulator current results from a comparison of one of the output voltages against a zener-derived reference, so it automatically adjusts to a level that holds the dc voltage constant. The

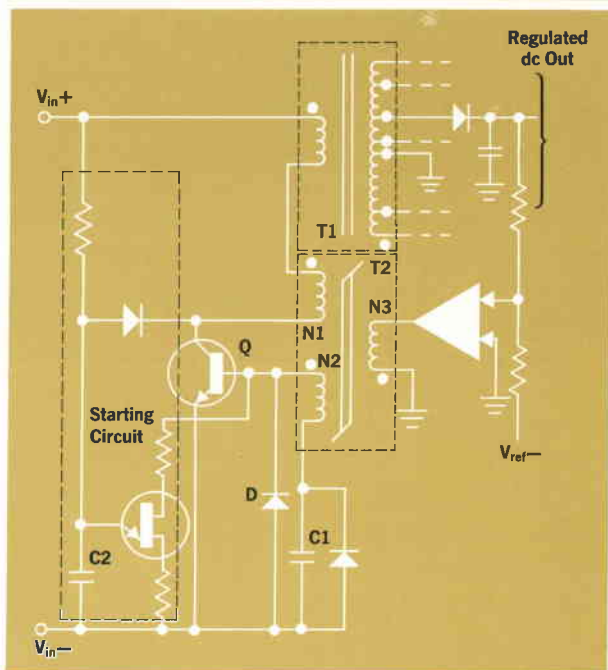

resulting pulse repetition rate may be between 10 and 40kHz, depending on the input voltage.

Of special importance, regulation is accomplished through transformer coupling so there is *no dc connection* between the oscillator circuit and the scope's circuits. As a result, the scope's signal inputs are isolated from the dc power input, eliminating any grounding problems caused by inverted dc sources, etc.

As the instrument is turned on, switching action is initiated by the starting circuit. When the voltage across capacitor C2 charges to the unijunction transistor firing level, the unijunction transistor 'kicks' the base of transistor Q to start the dc-dc converter. When Q turns on, it discharges C2, thus keeping the unijunction oscillation suppressed as long as the converter is working.

This power supply operates over a range of input voltages from less than 11.5V to more than 36V with an output dc change of only 2% (30mV on the +15V line). The internal batteries were selected to supply an input voltage near 24 volts, where efficiency peaks at 87%.

The power supply is fully protected against accidental application of the wrong voltage. If the wrong dc polarity is applied, a diode across the input limits the applied voltage and draws sufficient current to blow the dc input fuse. A voltage higher than 36 volts trips an SCR crowbar that also limits the voltage and blows the dc fuse.

The high-voltage supply for the CRT is a conventional 50kHz oscillator-transformer step-up circuit with a voltage tripler.

Low-Power Amplifier

The vertical amplifier in the 1700-series Oscilloscopes has a conventional configuration but with the design refined to obtain maximum performance from minimum power.

Investigation showed that this objective is best met by the 'series-shunt' configuration shown in the figure following (series feedback in the emitters of Q1-Q2, shunt feedback

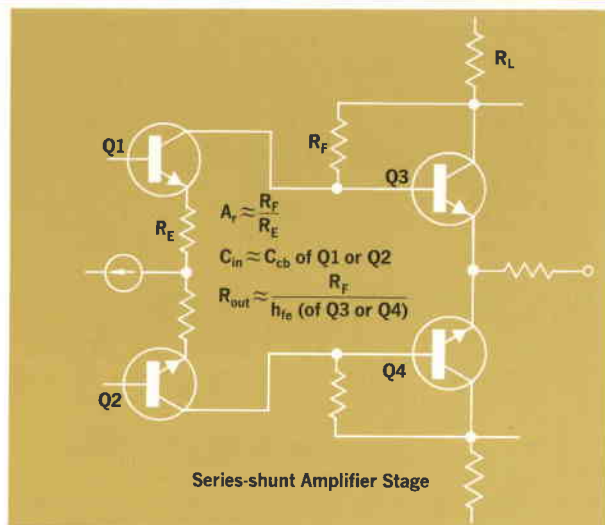

from collector to base in Q3-Q4). The low input capacitance and low output resistance of this type of amplifier means wideband performance at relatively low current. Two of these stages have enough gain to build up the signal sufficiently for driving the output stage.

Though the CRT has low drive requirements, the series-shunt amplifier doesn't have quite enough dynamic range to drive the CRT. This requirement is easily met by a low-power cascode circuit, as shown in the circuit below. This circuit consumes only 1.2 watts (in the 1700A and 1701A) so the transistors operate well within their ratings though standing in free air with no heatsinks whatever.

Channel switching takes place in the leads between Q1-Q2 collectors and Q3-Q4 bases of the first series-shunt stage. Transistor current switches are used, inserted here where the impedance is low so the additional capacitance introduced by the switches has little effect on amplifier performance. Each signal channel at this stage has the pair of input transistors Q1-Q2 but, because of the switching arrangement, share one pair of output transistors Q3-Q4.

A 160-ns delay line, that enables the signal to trigger the sweep before the signal gets to the CRT, precedes the second series-shunt stage.

In basic concept, the vertical amplifier in the 75MHz Model 1707A is similar except for the addition of one more amplifying stage. Since current requirements are proportional to frequency—the CRT is basically a capacitive load—current drain with 75MHz response is heavier too.

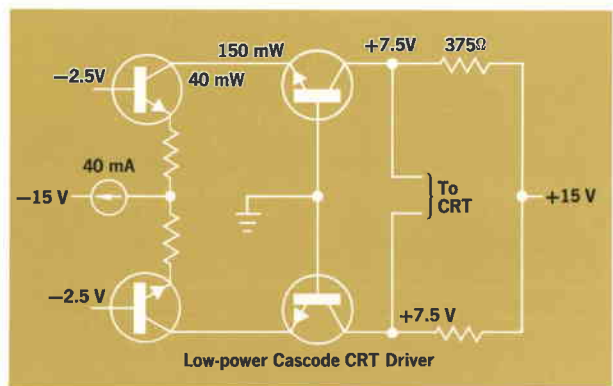



Fig. 6. Lower cost Model 1700A, for certain communications applications and others not requiring delayed sweep, has same 35 MHz vertical amplifier and 10 ns/div main sweep performance as Model 1701A, but omits delayed sweep.

operator first rotates the delayed sweep TIME/DIV control out of the OFF position. The display is then brightened for the duration of the delayed sweep, showing where it starts and for how long it lasts. The DELAY TIME control selects the point where the delayed sweep starts and the delayed sweep TIME/DIV control determines the duration. Once these have been set, the operator simply switches from MAIN to DELAYED SWEEP, and the brightened portion is expanded to full CRT display width. The delayed sweep's ability to trigger on the signal, following the selected delay pe-

riod, removes the jitter that so often occurs with highly expanded sweeps or with non-triggerable delay systems.

Less Time In The Shop

Calibration procedures have been shortened by reducing the number of internal adjustments to 45, as compared with the 70 or more in comparable instruments. For example, there is only one adjustment in the low voltage power supply, only two high-frequency adjustments in the vertical amplifier, and only four timing adjustments in each time base. If all 45 controls were misadjusted, a technician with a working knowledge of the scope could recalibrate it completely within an hour.

Serviceability is further enhanced by the use of plug-in assemblies allowing easy removal and replacement. Internal adjustments, test points, and connection points are clearly identified.

Fully Equipped

The new scopes come equipped with a front-panel cover, two probes, an assortment of probe tips, a polyester contrast screen for the CRT, an ac power cord, and a dc connector plug as standard equipment. The cover includes a storage space for probes and power cords and also has a table of operating instructions, permanently attached so it will be with the instrument whenever needed.

Optional accessories include, besides the battery pack, adapters for mounting the instrument on a test equipment cart, and a viewing hood that can be collapsed to fit inside the storage compartment.

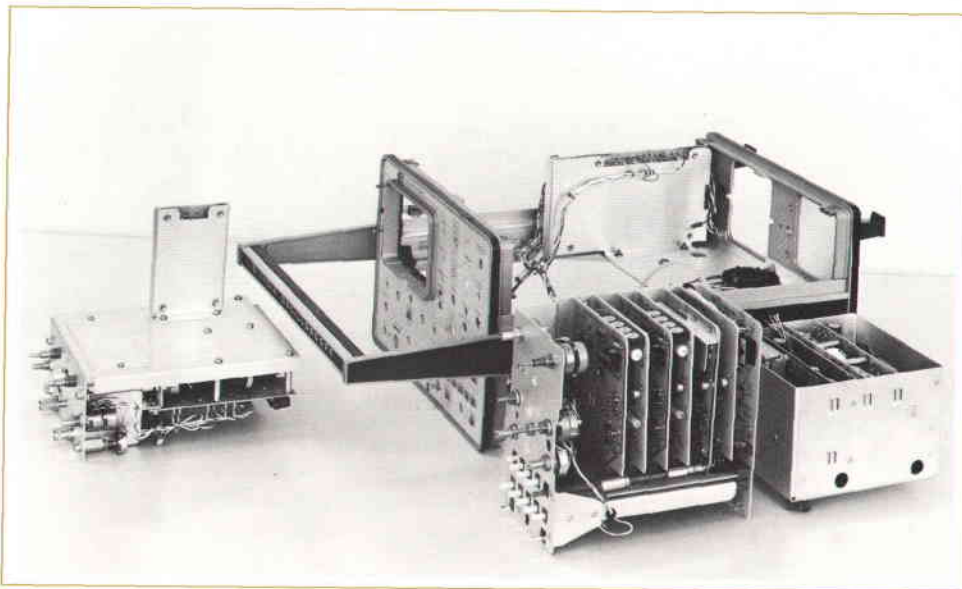

Fig. 7. Vertical amplifier, horizontal amplifier, and power supply are in separate modules that can be tested individually before final assembly. This, plus reduction in internal adjustments, reduces costs by shortening final test and alignment time. Sweep circuits and power supply have removable plug-in boards that can be changed in field to speed service turn-around time.



Fig. 8. Oscilloscope's form factor facilitates carrying. Handle locks in three different positions for either carrying instrument or elevating it on a bench for viewing. Snap-on front-panel cover has space for probes, power cord and other accessories.

Bob Mast



Bob Mast went straight to work on the 1700-series Oscilloscopes when he joined HP in 1968, developing both the low- and high-voltage power supplies, the gate amplifier, and the calibrator circuits. His previous experience included biomedical telemetry for EEG's while working towards his master's degree at the University of Wisconsin, where he also got his BSEE degree. Bob is a member of Eta Kappa Nu and IEEE.

Bob's a skier too but, by also enjoying hunting, fishing, and back-packing, he takes full advantage of those Colorado hills.

Acknowledgments

Much appreciation is due Milton Russell for the design of the CRT, and Chuck Donaldson for guidance in product definition. We also wish to thank LaVerne Gress and Stan Farr for their help in organizing all the myriad details required to keep the project rolling. 🙏

Tom Bohley

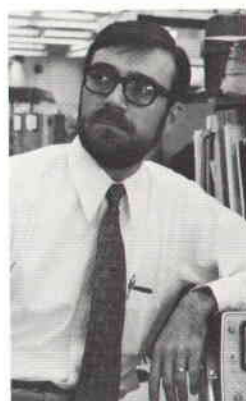

Tom Bohley started his career at HP in 1967 working with the leviathans — the 1300A 10-inch X-Y Display, 143A large screen, plug-in Oscilloscope mainframe, and 1308A/1309A 8-channel large-screen Medical Monitors before switching to the compacts. He headed up the 1700-series engineering effort and contributed the vertical amplifier, trigger and sweep circuits.

Tom earned both BSEE and MSEE degrees from the University of Missouri at Rolla where he was a member of Eta Kappa Nu, Tau Beta Pi, Phi Kappa Phi, and Sigma Xi. In common with all other Colorado immigrants he likes to ski but also indulges in scuba diving (in Colorado?) plus sports-car racing and rallying.

Don Bloyer



Don Bloyer was responsible for the mechanical design of the 1700-series Oscilloscopes in a coordinated effort that married the requirements for field service with the operational requirements of an oscilloscope. Before transferring to Colorado Springs and the 1700 series, he worked at the HP Loveland Division on the product design of the 3590A Wave Analyzer family and on the tool engineering for the 3480A Digital Multimeter family. He earned his BSME in 1967 at the

University of Minnesota and is presently working on his MBA at the University of Colorado.

Evidently spending more time outdoors than in, Don goes in for skiing, of course, and bicycling, golf, hunting, camping and handball. He is also goalie for the HP 'Hotspur' soccer team, a swimming official for a local high school and, as though all that weren't enough, he enjoys RC model airplaning.

SPECIFICATIONS
HP Models 1700A/1701A/1707A
Oscilloscopes

VERTICAL AMPLIFIERS

DISPLAY MODES: channel A; channel B; A and B alternately on successive sweeps (ALT); A and B on same sweep by switching between A and B at approx 100 kHz rate with blanking during switching (CHOP); A + B (algebraic addition).

BANDWIDTH (each channel), direct or with Model 10006B $\times 10$ Probe, 3 dB down from 50-kHz, 6-div reference signal from 25-ohm source:
DC-coupled: 1700A and 1701A, dc to 35 MHz;
1707A, dc to 75 MHz.

AC-coupled: low end cut-off at 10 Hz.

RISETIME: <10 ns (1700A, 1701A), <4.7 ns (1707A), 10% to 90% of 6 div input step from 25 ohm source direct or with Model 10006B probe.

DEFLECTION FACTOR:

RANGES: 10 mV/div to 5 V/div in 1, 2, 5 sequence. $\pm 3\%$ accuracy with vernier in CAL position.

VERNIER: continuously variable between ranges, extends maximum deflection factor to at least 12.5 V/div.

POLARITY: NORM or INV, selectable on channel B only.

SIGNAL DELAY: sufficient delay to view signal transition that triggers sweep.

INPUT RC: 1 megohm $\pm 2\%$ shunted by approx 27 pF (1707A, 24 pF).

INPUT COUPLING: AC, DC or Ground selectable. Ground position disconnects input and grounds amplifier.

A + B OPERATION

AMPLIFIER: bandwidth and deflection factors are unchanged; channel B may be inverted for A - B operation.

COMMON MODE (A - B):

FREQUENCY: dc to 1 MHz.

REJECTION RATIO: with common mode signal amplitude equivalent to 30 div, at least 40 db on 10 mV/div and at least 20 dB on all other ranges with verniers set for optimum rejection.

TRIGGER SOURCE:

NORM: on displayed signal in A, B, and A + B modes; on channel A in CHOP and ALT modes.

A ONLY: on channel A in all modes.

TIME BASE

SWEEP

RANGES: from 0.1 μ s/div to 0.2 s/div in 1, 2, 5 sequence. $\pm 3\%$ accuracy with vernier in CAL position.

VERNIER: continuously variable between ranges, extends slowest sweep to at least 0.5 s/div.

MAGNIFIER: expands all sweeps by factor of 10 and extends slowest sweep to 10 ns/div. Accuracy $\pm 5\%$.

SWEEP MODE

NORMAL: sweep is triggered by internal or external signal.

AUTOMATIC: bright baseline displayed in absence of input signal. Triggering same as normal for input signals above 40 Hz.

SINGLE: in normal mode, sweep occurs once with same triggering as normal; reset pushbutton arms sweep and lights indicator. In Auto mode, sweep occurs once each time Reset pushbutton is pressed.

TRIGGERING

INTERNAL: dc to 35 MHz on signals causing 0.5 division or more vertical deflection, or to 75 MHz on signals causing at least 1.5 division deflection (1700A, 1701A—1 div with 1707A), in all display modes except CHOP; dc to 100 kHz in CHOP mode.

EXTERNAL: dc to 35 MHz on signals 50 mV peak-to-peak or more, increasing to 100 mV peak-to-peak at 75 MHz.

EXTERNAL INPUT RC: 1 megohm $\pm 2\%$ shunted by approx. 27 pF.

LEVEL AND SLOPE

INTERNAL: at any point on vertical waveform displayed.

EXTERNAL: continuously variable from +1.5 V to -1.5 V (+15 V to -15 V in ± 10 on 1700A) on either slope of trigger signal. Maximum input, ± 100 V.

COUPLING: AC, DC, LF REJ, or HF REJ.

AC: attenuates signals below 20 Hz.

LF REJ: attenuates signals below 15 kHz.

HF REJ: attenuates signals above 30 kHz.

TRIGGER HOLD-OFF: time between sweeps continuously variable to more than 1 sweep time for sweep times 20 ms or faster.

DELAYED TIME BASE (Models 1701A and 1707A only)

SWEEP

RANGES: 0.1 μ s/div to 0.1 s/div in 1, 2, 5 sequence. $\pm 3\%$ accuracy with vernier in CAL position.

VERNIER: continuously variable between ranges, extends slowest sweep to 0.25 s/div.

TRIGGERING

INTERNAL: same as main time base.

AUTOMATIC: delayed sweep automatically triggered at end of delay time.

LEVEL AND SLOPE: at any point on waveform displayed.

COUPLING: AC or DC. AC attenuates signals below 20 Hz.

DELAY TIME: continuously variable from 0.1 μ s to 2 s.

DELAY JITTER: <0.005% (1 part in 20,000) of maximum delay in each main sweep time range.

TRACE INTENSIFICATION: in main sweep mode, rotating delayed sweep time base switch from OFF position intensifies that part of display that will expand to full screen when switched to delayed time base mode.

CATHODE-RAY TUBE AND CONTROLS

TYPE: post accelerator, 22kV overall accelerating potential; aluminized P31 phosphor standard; P2, P7, and P11 available.

GRATICULE: 6 x 10 div internal graticule; 0.2 subdivisions on major horizontal and vertical axes. 1 div = 1 cm.

BEAM FINDER: returns trace to CRT screen regardless of setting of horizontal, vertical, or intensity controls.

INTENSITY MODULATION: > +4 V, dc to 1 MHz blanks trace of any intensity. Input R, 1000 ohms $\pm 10\%$.

CALIBRATOR

TYPE: 1 kHz $\pm 10\%$ squarewave.

VOLTAGE: 1 V peak-to-peak, $\pm 1\%$.

POWER REQUIREMENTS

AC LINE: 115 or 230 V $\pm 20\%$, 48 to 440 Hz, 30 VA max (1700A and 1701A), 50 VA max (1707A).

DC LINE: 11.5 to 36 V, 18 watts max (1700A and 1701A); 25 watts max (1707A).

BATTERY (OPTIONAL)

OPERATING TIME: 1700A and 1701A, up to 6 hours; 1707A up to 4 1/2 hours.

LOW BATTERY INDICATOR: power light blinks to indicate that batteries are discharged and that further operation may open dc fuse.

RECHARGE TIME: 14 hours max with power switch off, if not operated after power indicator blinks. Batteries recharge whenever power mode switch is set to AC and AC power is applied. Full charge is applied with power switch off. With power switch on, trickle charge is applied.

GENERAL

WEIGHT

WITHOUT PANEL COVER: Net, 24 lb (11.0 kg); shipping, 35 lb (15.9 kg).

WITH PANEL COVER, ACCESSORIES, AND OPTIONAL BATTERY PACK: 35 lb (15.9 kg); shipping, 46 lb (20.8 kg).

ENVIRONMENT: Oscilloscopes operate within specifications over the following ranges.

TEMPERATURE: 0°C to +55°C.

HUMIDITY: to 95% relative humidity to 40°C.

ALTITUDE: to 15,000 ft.

VIBRATION: vibrated in three planes for 15 min each with 0.010-inch excursion, 10 to 55 Hz.

DIMENSIONS: 11 1/4 in. (286 mm) wide (not including handle), 7 1/8 in. (186 mm) high, 15 1/2 in. (400 mm) deep from front panel to furthest rear extension.

ACCESSORIES FURNISHED: mesh contrast filter, front panel storage cover, two Model 10006B $\times 10$ Probes, one dc power plug, one ac power cord with right angle plug, and one instruction manual.

PRICE: Model 1700A, \$1680; Model 1701A, \$1800; Model 1707A, \$1925; Model 10103A battery pack, \$200.

AVAILABLE OPTIONS

16: TV sync separator; \$85.

20 (1700A): external horizontal input and Channel A output;* \$50.

20 (1701A, 1707A): external horizontal input, Channel A output,* mixed sweep, and calibrated sweep delay; \$125.

* When cascaded into channel B, provides 1 mV/div deflection factor with reduced bandwidth.

MANUFACTURING DIVISION: COLORADO SPRINGS DIVISION
1900 Garden of the Gods Road
Colorado Springs, Colorado 80907

NBS Publishes Revised List Of Physical Constants

THE NATIONAL BUREAU OF STANDARDS, U.S. Department of Commerce, has published a new interim set of values for the physical constants as a part of the ninth printing of its Handbook of Mathematical Functions.¹ The new values are based on the most recent comprehensive adjustment of the constants by Taylor, Parker, and Langenberg,² who carried out a least-squares analysis of the earlier data combined with a large body of new measurement results reported by physicists since 1963 when Cohen and DuMond completed the last major readjustment.³ Many of the new measurements were obtained with considerably improved techniques; particularly noteworthy was the successful application of the ac Josephson effect to the determination of the ratio of the electronic charge to Planck's constant.⁴

A list of some of the more widely used constants is shown in Table I.

This shorter table will also be used in a revised edition of the NBS wallet-card list of General Physical Constants.⁵ The Defined Values and Conversion Factors, shown here as Table II, will also appear on the card, as well as definitions of the base units of the modernized metric system, the International System of Units (SI).⁶

Activity in the measurement of physical constants continues at so high a rate that an official readjustment has been initiated by the Task Group on Fundamental Constants of the Committee on Data for Science and Technology, International Council of Scientific Unions. This, however, may take a year or two. Meanwhile, it is generally agreed that the TPL values not only best represent the information available through mid-1969, but that the results of the next readjustment will be much closer to the TPL values than to the 1963 Cohen and DuMond values. 

The International System of Units (SI)

The International System of Units (SI), established in 1960 by the General Conference of Weights and Measures under the Treaty of the Meter, is based on: the meter (m) for length, defined as 1 650 763.73 wavelengths in vacuum corresponding to the transition $2p_{10}-5d_5$ of krypton 86; the kilogram (kg) for mass, defined as the mass of the prototype kilogram at Sevres, France; the second (s) for time, defined as the duration of 9 192 631 770 periods of the radiation corresponding to the transition between the two hyperfine levels of the ground state of cesium 133; the kelvin (K) for temperature, defined as 1/273.16 of the thermodynamic temperature of the triple point of water; the ampere (A) for electric current, defined as the current that, if flowing in two infinitely long parallel wires in vacuum separated by one meter, would produce a force of 2×10^{-7} newton per meter of length between the wires; and the candela (cd) for luminous intensity, defined as the luminous intensity of 1/600 000 square meter of a perfect radiator at the temperature of freezing platinum.

TABLE I
GENERAL PHYSICAL CONSTANTS

Constant	Symbol	Value	Uncertainty	Units: Systeme Int'l (SI)
Speed of light in vacuum	c	2.997 925 0	± 10	$\times 10^8$ m/s
Elementary charge	e	1.602 191 7	70	10^{-19} C
Avogadro constant	N_A	6.022 169	49**	10^{23} mol ⁻¹
Atomic mass unit	u	1.660 531	11**	10^{-27} kg
Electron rest mass	m_e	9.109 558	54	10^{-31} kg
Proton rest mass	m_p	1.672 614	11**	10^{-27} kg
Faraday constant	F	9.648 670	54**	10^4 C/mol
Planck constant	h	6.626 196	50	10^{-34} J·s
Fine structure constant	α	7.297 351	11	10^{-3}
Charge to mass ratio for electron	e/m_e	1.758 802 8	54	10^{11} C/kg
Rydberg constant	R_∞	1.097 373 12	11	10^7 m ⁻¹
Gyromagnetic ratio of proton (uncorrected for diamag., H ₂ O)	γ_p	2.675 196 5	82	10^8 rad·s ⁻¹ T ⁻¹
Bohr magneton	μ_B	9.274 096	65	10^{-24} J/T
Gas constant	R	8.314 34	35	10^8 J·K ⁻¹ ·mol ⁻¹
Boltzmann constant	k	1.380 622	59	10^{-23} J/K
First radiation constant (h·c)	C_1	4.992 579	38	10^{-24} J·m
Second radiation constant (h·c ²)	C_2	1.438 833	61	10^{-2} m·K
Stefan-Boltzmann constant	σ	5.669 61	56	10^{-8} W·m ⁻² ·K ⁻⁴
Gravitational constant	G	6.673 2	31	10^{-11} N·m ² /kg ²

*Based on 1 std. dev.; applies to last digits in preceding column.
**These values may be in conflict with data available since the Taylor, Parker, Langenberg review. Pending a complete new readjustment of the constants, it would be prudent to multiply the above uncertainties by 2.

TABLE II
DEFINED VALUES AND CONVERSION FACTORS

Atomic mass unit (u)	1/12 the mass of an atom of the ¹² C nuclide
Standard acceleration of free fall	9.806 65 m/s ²
Standard atmosphere	101 325 N/m ²
Thermochemical calorie	4.184 J
Int. Steam Table calorie	4.1868 J
Liter	0.001 cubic meter
Mole (mol)	amount of substance comprising as many elementary units as there are atoms in 0.012 kg of ¹² C
Inch	0.0254 m
Pound, avdp	0.453 592 37 kg

References

- Chapter 2, NBS Applied Mathematics Series 55, Handbook of Mathematical Functions, Ninth Printing, Feb. 1971.
- B. N. Taylor, W. H. Parker, and D. N. Langenberg, Rev. Mod. Phys. Vol. 41, p. 375 (1969). Also available in book form: 'The Fundamental Constants and Quantum Electrodynamics' by same authors, Academic Press, New York 1969.
- NBS Tech. News Bull. Vol. 47, p. 175 (Oct. 1963).
- B. N. Taylor, D. N. Langenberg, and W. H. Parker, 'The Fundamental Physical Constants', Scientific American, pp. 62-73 (Oct. 1970).
- General Physical Constants, NBS Special Publication 344 (supersedes NBS Misc. Publ. 253), plastic card 2½ x 3¾ inches.
- For the full official description of the system, see 'The International System of Units (SI)', NBS Special Publication 330, in press.

Effective Stripline Device Characterization

Characterizing stripline devices for high-frequency designs requires more than elegant instrumentation—demands placed on the device-handling hardware are surprisingly severe.

By George R. Kirkpatrick

IN THE DESIGN OF COUNTERS, high-speed digital circuits or high-frequency oscilloscopes, in exploring circuit behavior of any kind at high frequencies, problems often arise in using the z , y or h parameter methods of circuit characterization. Some of the low-frequency methods of characterizing components turn out to be impractical or to have unacceptable errors at these higher frequencies.

When these considerations are germane, perhaps it is time to consider scattering parameters as a design tool. Engineers working with microwave sources, modulators and amplifiers have been using scattering parameters to characterize transistor and other active and passive components quickly and accurately. They then analyze their completed circuits using these same s -parameters. This procedure has been proved by now to reduce engineering time and costs, and to result in better, more predictable products.¹

Elegant instrumentation exists, to measure those relations which constitute s parameters.^{2,3,4} It is common, however, to find that the greatest handicap to the effective, efficient use of s -parameter analysis is the absence of convenient, precise hardware to handle the device under test. This has been especially true of stripline devices, including those in widely-used standard packages. Where the aim is measurements adequate for predictions leading to *optimum* designs, the degree of sophistication required in handling the tested device is surprisingly high. To make such measurements, both of active and passive stripline components, new fixtures and a new test set have been designed to work with the familiar HP Microwave Network Analyzer (Fig. 1).

Fixtures

The HP 11608A Stripline Transistor Fixture accepts



Fig. 1. The 8746B s -parameter test set measures all 4 two-port parameters of active or passive devices when used with the 8710A Network Analyzer system.

striplines of the TI-line type (Option 002) and the K-disc type (Option 003). There is also a form of this fixture which allows one to machine it so as to accommodate other transistor packages, diodes, resistors, capacitors, etc. (Option 001).

The HP 8746B S -parameter Test Set is aimed especially at making it easy to measure the *small-signal* parameters of active devices. However, it has versions for the measurement of devices at the larger signal levels.

The Network Analyzer System

Fig. 2 illustrates how these instruments work with a network analyzer system. An rf signal is applied to the 8746B. This signal is split into two channels; for convenience we call these the *reference* and *test* channels. The *reference* signal is conditioned to give the proper phase relationship to the test signal that is directed by rf switches to the 11608A stripline fixture. Depending on

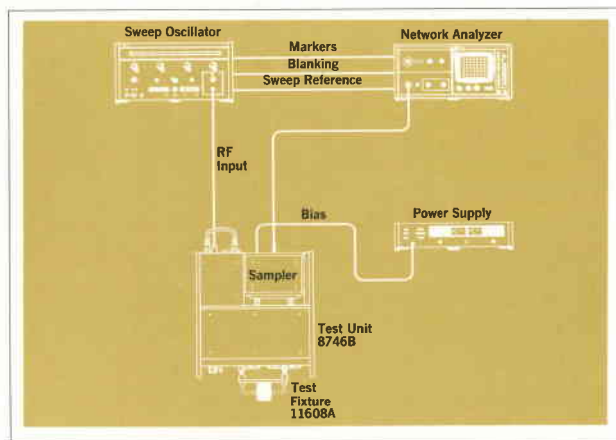

Fig. 2. The HP 8410 Network Analyzer measurement system with the 8746B and 11608A connected into the system.

the parameter being measured, this incident signal is reflected from or transmitted through the device under test, located in the 11608A, and then directed to the network analyzer.

The analyzer then compares these signals in the reference and test channels and displays the selected parameter information in either polar (8414A) or semilog (8412A) form.

S-Parameter Test Set

The rf circuit and the bias connections of the 8746B are shown in Fig. 3. An rf signal entering the instrument goes first to a directional coupler which separates a portion of the signal and sends it to two devices which compensate for phase length. The first of these is a section of semirigid coax cable which can be inserted to make large changes in reference channel length. The second is a calibrated, precision line stretcher capable of a 15 centimeter change in reference plane position. (30 centimeters of reference channel length is added with the line stretcher to change the reference plane 15 centimeters because the signal must travel into the device under test and then back out.) The reference signal then passes through a 10 dB pad which reduces the signal level to a value compatible with the frequency converter at the input of the measuring system. It also provides a good impedance match at the reference output connector.

The signal traveling along the main line of the reference coupler is connected to the 70 dB programmable step attenuator.⁵ This rf attenuator allows the user to change the level at the test port in 10 dB increments, without affecting the reference channel level. When the attenuator is switched, however, some relative phase shift between reference and test channels will occur.

The attenuator is used when making gain or small signal measurements.

Next the test signal enters the first of two switch trees which 1) directs the signal to the selected port coupler, 2) provides high isolation-between the two test channels, and 3) terminates the unused arm of the port coupler in a 50-ohm load.

As the signal enters a port coupler it must travel from the auxiliary line to the main line before it appears at the test port. In so doing, the signal level is reduced by the coupling factor. Not only does this yield a signal of lower power at the test port, but the test port power tracks the reference output power regardless of normal coupling factor variations!

The second switch tree selects one of the coupler main line return signals and connects it to the test output connector. A series dc blocking capacitor and a pair of inductive bias connections are part of the coupler main-line circuit as well as a 10 dB pad that provides good source and return impedance match. The bias connections are placed behind the coupling area. With this arrangement the directivity is not reduced due to bias network reflections.

S-parameter selection and incident wave attenuation are controlled either by front panel push button or by remote switch closures connected through a 36 pin connector on the rear panel of the 8746B. Remote control mode is selected by a switch closure through the same connector. When either the remote control or manual mode is selected the other is locked out, preventing control problems. The 8746B S-parameter Test Set is directly compatible with HP automatic network analyzers.

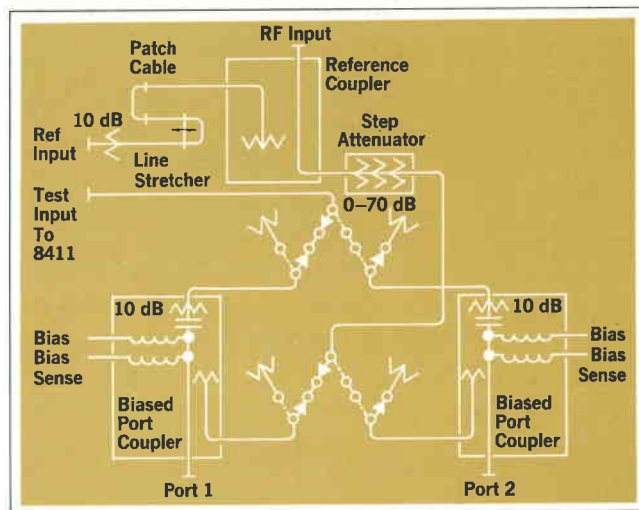

Fig. 3. 8746B RF schematic, showing component arrangement and location of the bias circuits. Switches are shown in the S_{11} position.

The 11608A Stripline Transistor Fixture

Design objectives for the 11608A Stripline Transistor Fixture included building an accurate, easy-to-use device which would closely approximate the environment that a stripline device should encounter in an actual circuit.

One of the major problems encountered in using active devices at microwave frequencies is excessive lead length. As an example, the dominant factor establishing unity-gain crossover frequency, for a microstrip IC used as a common emitter amplifier, is the inductance of the bonding wire to the emitter of a chip transistor, even though that lead is only about 0.015 inch long.

In a common base configuration, excess common lead inductance can even cause a negative real input impedance to occur. Any length of conductor required to 'ground' the common lead contributes to this inductance. To compensate for this, the ground plane in the 11608A fixture is extended to meet the common lead, and the input and output microstrip transmission lines are brought right to the edge of the transistor package. The transistor is so set into the stripline and ground plane that there is no need to bend the leads, and thus no need to add lead length (see Fig. 4).

Another obvious objective was to build a fixture with low VSWR. Since the fixture is imposed between the transistor and the measuring device, any VSWR adds directly to measurement error. Low VSWR has been achieved; it is at most 1.10:1 through 4 GHz and more typically is <1.06 for both arms of the fixture and the

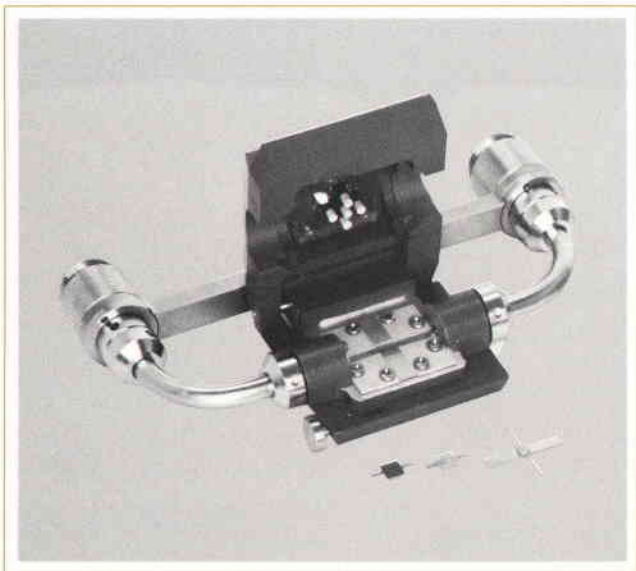

Fig. 4. The 11608A Option 003 for K-disc transistors. Note stripline is extended to the edge of the transistor package at lead level, and the ground plane is raised to avoid lead bending.

through section calibrator.*

Another factor that contributes to measurement error is not so obvious: insertion loss. This affects the reflection measurements by effectively reducing the test set directivity by twice the insertion loss of the fixture from connector to transistor. This loss has been kept to a minimum, less than 0.31 dB at 4 GHz, by using low-loss teflon-filled semirigid coax line and a fairly small section of the PPO** stripline. This insertion loss does not affect transmission measurements since it is removed by the calibration procedure.

A reason, other than reducing loss, for making the stripline area small is to reduce the size of the cavity formed by the fixture. This in turn increases the frequency of the first high order mode that can exist in that cavity to a value high enough to be effectively suppressed by the absorptive polyiron placed in the fixture cover. Moding within the fixture would be detected as an abrupt increase in the insertion loss as tested with the 50 ohm through line calibrator. This fixture is usable to frequencies higher than 12.4 GHz without moding problems.

When a transistor is placed in the 11608A and the cover is closed, four dielectric pressure pads are forced against the transistor leads and one against the transistor body. It is essential that all leads and the case make solid contact at their matching surfaces to prevent unwanted modes and consequent measurement errors. Good contact requires the transistor to be clean and to have its leads straight and flat.

The stripline width is reduced in the contact area to compensate for the dielectric pads which would otherwise lower the line impedance.

If we consider an active device exhibiting negative resistance, we will see the importance of 1) the use of s-parameters, whose measurement requires the input and output of the test device to be terminated in 50 ohms, 2) the need for low source and terminating reflections from the fixture and the interconnecting hardware, and 3) minimizing lead parasitics. An active device with negative resistance exhibits the equivalent of a reflection coefficient magnitude greater than one. If the product of the magnitude of this reflection coefficient times the source reflection coefficient (the combination of items 2 and 3 above) is greater than one, a potentially unstable condition exists; because the system reflection coefficient is close to zero, the product is less than one, and oscilla-

* Two calibrators are supplied with the Option 002 and 003 fixtures. One is a short circuit designed to establish the reference plane accurately, at the edge of the transistor body. The other, the through line section, is a low reflection stripline whose electrical length is given so that transmission measurements can also be accurately referenced to the edge of the transistor.

** General Electric Co.

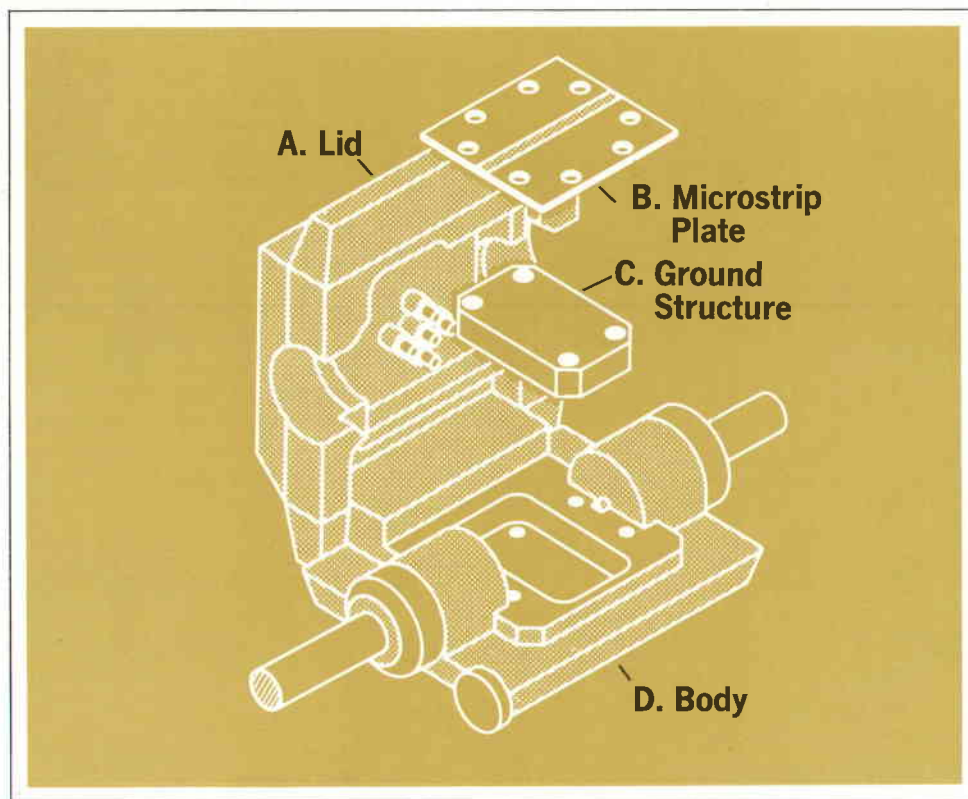

Fig. 5. 11608A Option 001 Fixture, exploded view. The ground structure and microstrip plate are machinable by the user to accommodate any active or passive device or circuit that will fit within the physical limits of the fixture.

tion will be most unlikely. To measure z , y , or h parameters, entailing short or open-circuit sources, the reflection coefficient magnitude equals one, and a potentially unstable condition will always exist; any oscillation will preclude z , y , or h parameter measurements.

Characterizing Other Devices

One might wonder, what can be done to fill the need to characterize other, less common stripline packages, or stud-mounted transistors? How about the s -parameters of series and shunt resistors or capacitors? Yet another kind of fixture is needed. The 11608A Option 001 is shown in Fig. 5. This option makes it possible for the user to create exactly the conditions a component will encounter in a practical circuit. It may be any active or passive component that can be contained within the physical limits of the fixture. If a circuit is to have a biasing resistor in a base circuit the resistor can be characterized as a shunt element and the measurement would include the effect of capacity between the resistive film and the ground plane and the reactance at the resistor leads. The fixture also makes it possible to test combinations of components or even complete circuits if the dimensions do not exceed a one inch square.

Conclusion

When components are completely characterized in

s -parameters, a high-frequency circuit can be analyzed just as easily as a low-frequency circuit is analyzed with h , y and z parameters. At present, powerful computer programs exist for analyzing and optimizing circuits characterized with s -parameters.

What often stands in the way of effective s -parameter characterization is the seemingly mundane matter of device handling; elegant instrumentation has been available for a good while. The requirements for efficient, effective manipulation of devices under test are surprisingly sophisticated.

The instrumentation system described in this article with modern network analyzer equipment and contemporary computer programs, give the circuit designer tools with which he can design optimum high-frequency circuitry quickly, and predict its actual performance accurately.

Acknowledgment

Design of the 11608A Stripline Transistor Fixture was by Richard A. Lyon and Robert W. Immergluck. Design of the 8746B was by George R. Kirkpatrick and Richard R. Borg. 📄

References

1. S-Parameters . . . Circuit Analysis and Design, Hewlett-Packard Application Note #95.
2. Microwave Network Analyzer Applications, Hewlett-Packard Application Note #117-1.
3. Stripline Component Measurements With the 8410A Network Analyzer, Hewlett-Packard Application Note #117-2.
4. S. F. Adam, Microwave Theory and Applications, Prentice Hall, New York.
5. Stephen F. Adam, 'Programmable Step Attenuators Use Distributed-Thin-Film Attenuator Card,' **Hewlett-Packard Journal**, April, 1971.

George R. Kirkpatrick



Bob Kirkpatrick has been developing waveguide and coaxial components for HP since 1956. He was project supervisor for the 8746B and other coaxial components and signal conditioning instruments associated with the HP Network Analyzer system. Bob graduated from California State Polytechnic College in 1953 with a B.S. degree in electronics and radio engineering, and is now finishing his work toward an MSEE degree at the University of Santa Clara.

He is the author of a paper on waveguide bridges and an earlier *Journal* article.

SPECIFICATIONS

HP Model 8746B S-Parameter Test Set (0.5 to 12.4 GHz)

FUNCTION: Wideband RF power divider and reflectometer with calibrated line stretcher and selectable 0-70 dB incident signal attenuator. Provides internal bias tees for completely characterizing two port active devices.

FREQUENCY RANGE: 0.5 to 12.4 GHz.

DIRECTIVITY: 30 dB, 0.5 to 4.0 GHz; 26 dB, 4.0 to 12.4 GHz.

SOURCE MATCH: $|ρ| ≤ 0.13 (≤ 1.3 \text{ SWR})$.

RETURN MATCH: $|ρ| ≤ 0.13 (≤ 1.3 \text{ SWR})$.

INSERTION ATTENUATION: 0-70 dB in 10-dB steps. Attenuation is $±5\%$ of indicated value.

REFERENCE PLANE EXTENSION: Adds 0-15 cm (30 cm in transmission path) to reference line; calibrated by digital dial indicator. Indicator is adjustable for initial calibration.

CONNECTORS:

RF INPUT: Type N female, stainless steel.

TEST PORTS: APC-7.

8411A: Mates with APC-7 precision connectors.

INSERTION LOSS: RF Input to Test Port, nominal 21 dB.

* Equivalent source reflection when used with the Network Analyzer.

REMOTE PROGRAMMING: Remote s-parameter selection by closing contacts on 36-pin rear panel connector to common pin. Short circuit current, 12 mA; open circuit voltage, 12 V dc.

TRANSISTOR BIASING: Bias and bias sensing connections are made to the biasing networks built into the 8746B via the 36-pin rear panel connector.

MAXIMUM BIAS: $±100 \text{ V dc}$, 500 mA. 1 A maximum when bias and bias sense circuits are operated in parallel.

CONFIGURATION:

STANDARD: Recommended for small signal measurements, has the optimum S/N ratio.

OPTION 001: Provides 10 dB higher power level at the test port. Enables large signal parameter measurements.

OPTION 002: Provides 20 dB higher power level at the test port and 10 dB greater dynamic range. Source and Return Match specifications are degraded. Recommended for Automatic Network Analyzer Systems only.

WEIGHT: Net, 35 lb (16.1 kg). Shipping, 42 lb (19.1 kg).

DIMENSIONS: 5½ in high, 16¾ in wide, 18¾ in deep (140 x 426 x 467 mm).

PRICE: \$5,000.00 (for all configurations).

SUPPLEMENTARY OPERATING CHARACTERISTICS:

FREQUENCY RESPONSE (AMPLITUDE, PHASE):

1.5 dB, $±7^\circ$, 0.5 to 2 GHz.

1.5 dB, $±7^\circ$, 2.0 to 8.0 GHz.

2.5 dB, $±7^\circ$, 8.0 to 12.4 GHz.

11608A

Transistor Fixture

FUNCTION: Provides the capability of completely characterizing stripline transistors in either the T1-line or K-disc package styles. For special package styles, a through-line microstrip and bolt-in grounding structure machinable by customer is available.

FREQUENCY RANGE: DC to 12.4 GHz.

INSERTION LOSS: $[0.15 + 0.04 F(\text{GHz})] \text{ dB}$ to center line.

PACKAGE STYLES:

OPTION 01: Through-line microstrip (P.P.O. plastic) and bolt-in grounding structure machinable by customer for special package styles.

OPTION 2: T1-line (0.250 in diameter).

OPTION 03: K-disc (0.205 in diameter).

CHARACTERISTIC IMPEDANCE: 50 ohms.

SUPPLEMENTARY OPERATING CHARACTERISTICS:

VSWR: (Measured with through-line calibration unit inserted and one end of the fixture terminated in a 50-ohm load).

<1.10 to 4 GHz.

<1.15, 4 GHz to 8 GHz.

<1.30, 8 GHz to 12.4 GHz.

CONNECTORS: APC-7 hybrid connectors. Mates with 8746B s-parameter test set. Spacing, 4.810 in.

OPTION 100: Precision Type N connectors.

CALIBRATOR OPTIONS 002 and 003 are supplied with two calibration references:

1. Short-circuit termination.

2. 50-ohm through-section.

MICROSTRIP MATERIAL: 0.031 in polphenylene oxide P.P.O.; 0.080 in wide 50-ohm stripline.

MAXIMUM POWER: 10 W including RF signals.

PRICES: Model 11608A - APC-7 hybrid connectors

OPTION 001: Machinable for custom packages

\$375.00

OPTION 002: T1-line (0.250 in diameter)

\$400.00

OPTION 003: K-disc (0.205 in diameter)

\$400.00

With Type N (female) connectors, Option 1 less

\$ 30.00

HEWLETT-PACKARD JOURNAL MAY 1971 Volume 22 • Number 9

FROM THE LABORATORIES OF HEWLETT-PACKARD COMPANY 1501 PAGE MILL ROAD, PALO ALTO, CALIFORNIA 94304 U.S.A.
Hewlett-Packard S.A. 1217 Meyrin - Geneva, Switzerland • Yokogawa-Hewlett-Packard Ltd., Shibuya-Ku, Tokyo 151 Japan

Editor: R. H. Snyder Editorial Board: R. P. Dolan, H. L. Roberts, L. D. Shergalis Art Director: Arvid A. Danielson Assistant: Maridel Jordan

HP Archive

This vintage Hewlett-Packard document was
preserved and distributed by

www.hparchive.com

Please visit us on the web!

On-line curator: John Miles, KE5FX

jmiles@pop.net

