

HEWLETT-PACKARD JOURNAL

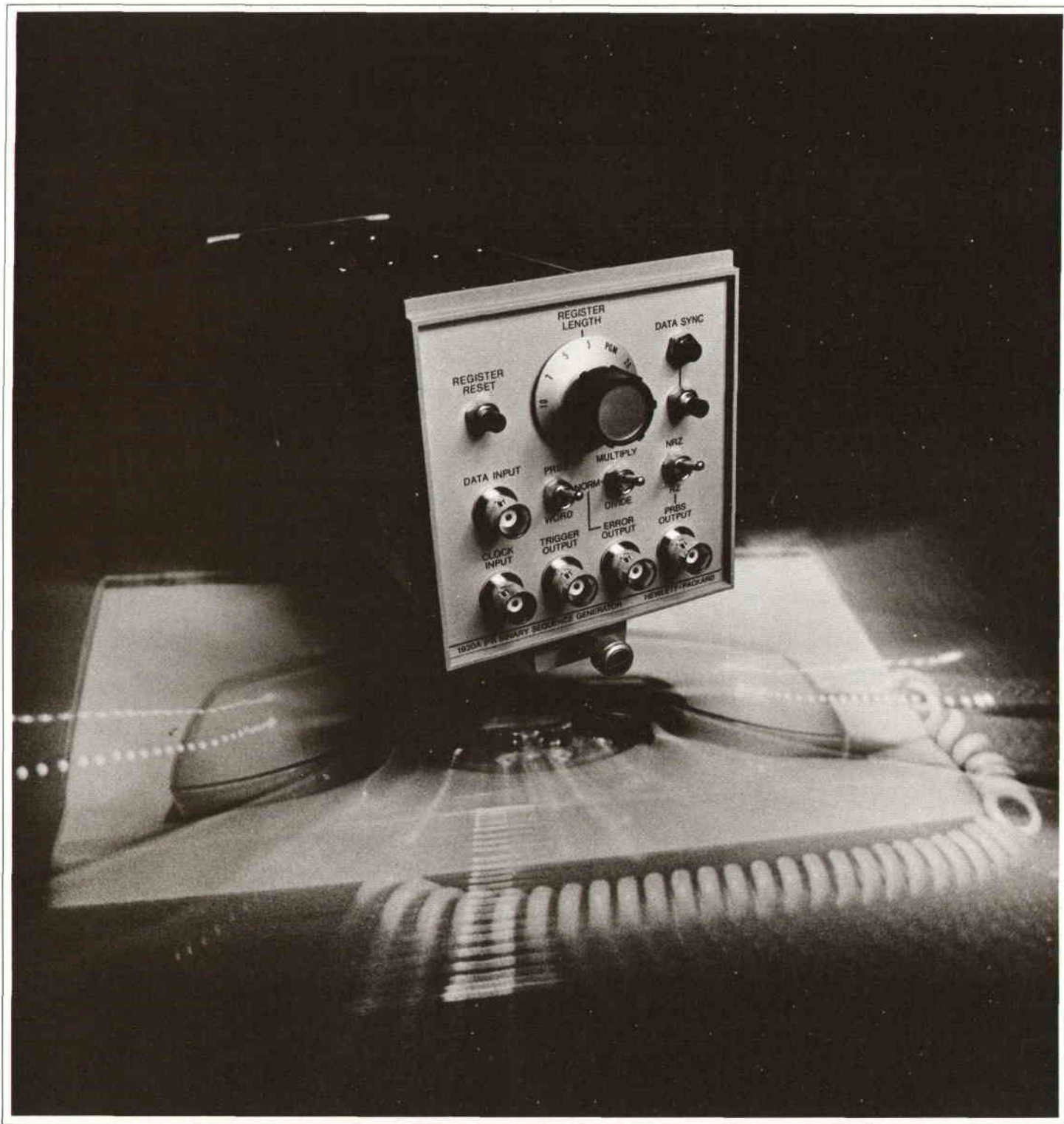

APRIL 1971

Manipulating Digital Patterns With a New Binary Sequence Generator

By Edward S. Donn

FROM SIMPLY BEING A MATHEMATICAL CURIOSITY fifteen years ago, binary sequence generating shift registers have become important tools in a surprising range of applications. The random-like patterns of 1's and 0's generated by these circuits are used to obtain increased range in radars,¹ to encode and decode digital and analog data for secure storage and transmission,² to encode and decode digital messages for error-free transmissions,³ to simulate digital data for system tests, and to generate random numbers for Markov simulation studies.⁴

To meet an incipient demand for test instruments capable of generating pseudorandom binary sequences, a binary output was included in the Hewlett-Packard Model 3722A Noise Generator, introduced in 1967.⁵ The binary output is a two-level waveform that switches levels in synchronism with regularly-occurring clock pulses. Switching does not occur on every clock pulse, however, but on a random-like selection of clock pulses that give the waveform nearly ideal statistical characteristics. The fact that the sequences can be repeated, though, means that the sequences are *pseudorandom*.

More recently, HP introduced the 1925A⁶ and 8006A Word Generators. These generate 16- and 32-bit words for de-bugging circuits with known short words but can also generate pseudorandom binary sequences for simulating digital data streams.

Increased Flexibility

Now, because of the widening applications for this kind of instrument, a new Pseudo-Random Binary Sequence (PRBS) Generator (Model 1930A) has been designed. A ¼-width module for the HP 1900-series Pulse Generators (Fig. 1), this instrument is the first

to give the operator complete control over the feedback configuration in the sequence-generating shift register, making possible more than a million different sequences, some 73,000 of them being maximal length sequences.

Another first-time capability: the new PRBS generator can *process* digital sequences as well as generate them. For example, it can encode and decode externally-gen-

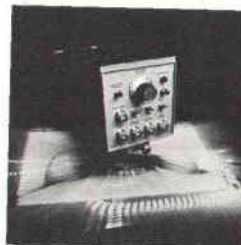

Cover: Model 1930A Pseudo-Random Binary Sequence Generator, a new addition to the 1900-series pulse-processing modules, contributes both a test pattern and a means of detecting errors in tests of digital transmission system quality.

The most flexible binary sequence generator yet offered in a commercial instrument, it can also encode and decode digital messages, and generate random-like sequences of 1's and 0's.

In this Issue:

- Manipulating Digital Patterns With a New Binary Sequence Generator, by Edward S. Donn* page 2
- How to Make a Nuclear Spectrum Hold Still, by Steven Upshinsky* page 9
- Astronomers Find Optical Timing Of Pulsars More Accurate, by Laurence D. Shergalis* page 12
- Programmable Step Attenuators Use Distributed-Thin-Film Attenuator Cards, by Stephen F. Adam* page 14

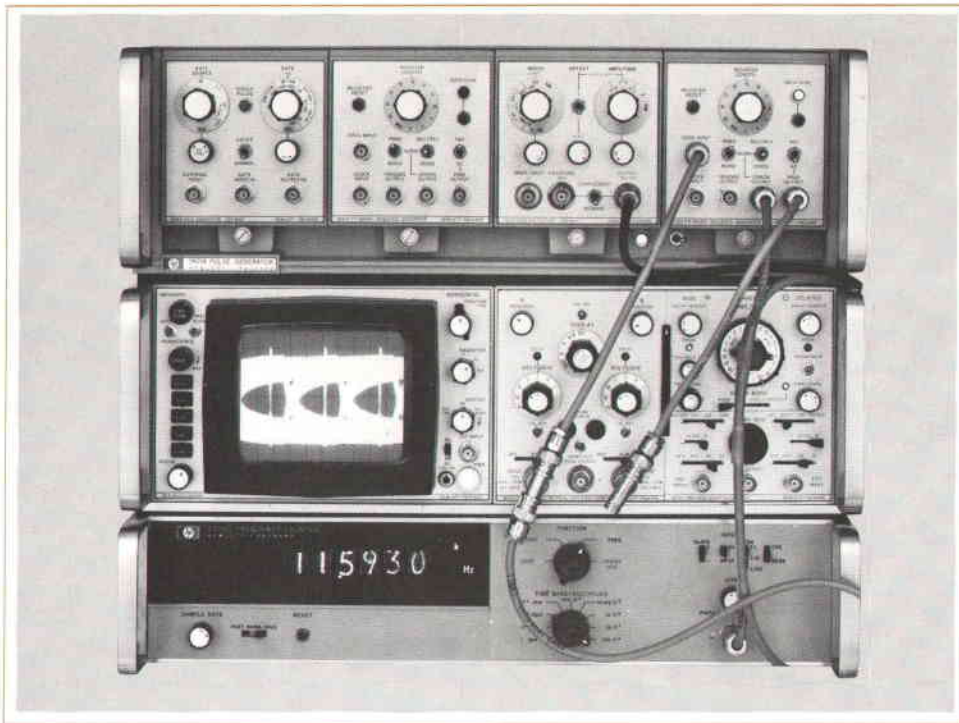

Fig. 1. Model 1930A PRBS Generator is a ¼-width plug-in for Hewlett-Packard 1900-series modular Pulse Generators. 1900 system allows selection of rate generators, delay generators, and pulse amplifier and shaping modules to match 1930A capabilities to wide variety of tasks.

erated data streams. It can also compare an externally-generated data stream with its own internally-generated replica to detect differences between the two (Fig. 2). For sequential comparisons and decoding, a new method

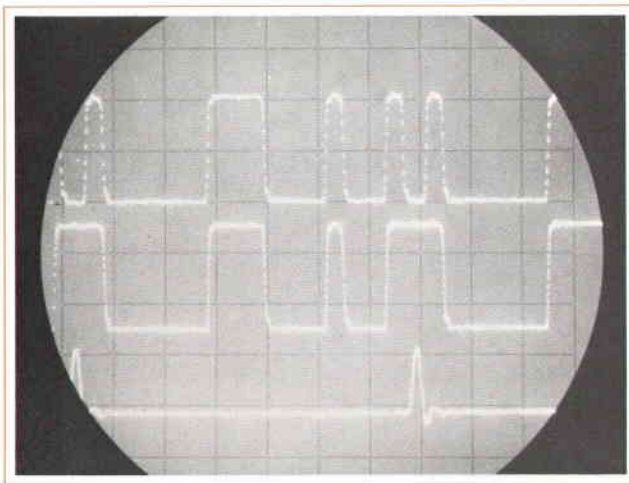

Fig. 2. Model 1930A generates error pulse (bottom trace) whenever input data stream (top trace) differs from internally-generated sequence (center).

of data synchronization lets the operator align the internal sequence with an external sequence in just a few clock pulses.

Applications

And where are these capabilities useful? A major application will be in checking the error rate of digital

transmission systems. A typical loop-around test is shown in Fig. 3. One PRBS Generator outputs a pseudo-random test pattern, the other compares the same pattern, as generated internally, with the pattern as received at the end of the loop, producing an 'error' pulse each time the patterns differ. The counter measures the rate at which the errors occur. For example, if the counter displayed 1.26 kHz, and the digital clock rate were 1 MHz, the error rate would be 1.26×10^{-3} , or 1.26 errors for every 1000 bits. This kind of figure is a measure of the quality of digital transmission systems.

The new PRBS Generator will also be useful as a digital simulator for testing digital circuits and memories with the varied patterns found in actual use. All possible combinations of up to twenty 1's and 0's (except all 0's) can be generated by this instrument.

Computer programs based on the use of random numbers can use the sequences generated by PRBS generators. But, since the patterns are repeatable, statistical variation is removed. Furthermore, repeatable sequences simplify de-bugging.

Encoding data for transmission and storage is another application. Whereas this capability of linear sequential circuits has already been exploited for traditional cryptographic purposes, the availability of a commercially-built instrument makes the technique applicable in any area where security is desired in the transmission and storage of data.

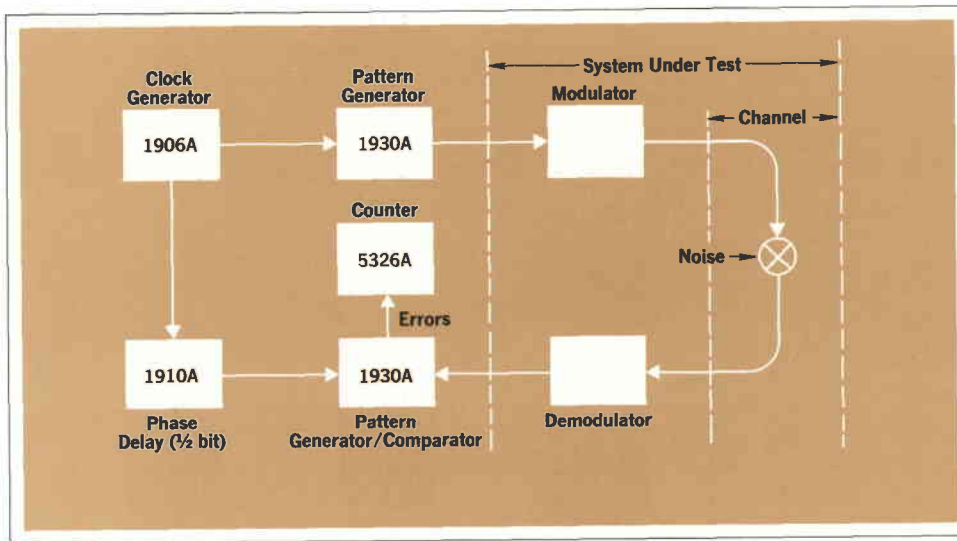

Fig. 3. Loop-around test of digital data transmission system uses one 1930A to generate test pattern and one 1930A to detect transmission errors (see text). Counter measures error rate. Delay Generator shifts phase of clock pulses to prevent overlap with incoming pulse transitions.

The patterns generated by this instrument will be highly useful for systems that use correlation techniques to elicit desired information. For example, space tracking radars transmit pulse trains with a random distribution of pulses and no-pulses. The reflected return signal is compared with time-shifted versions of the transmitted pulse pattern. The time shift that gives the best match (highest correlation) is then the round-trip signal time, giving range with high accuracy without requiring narrow pulses to get high resolution.

Specifically, these are the Model 1930A PRBS Generator's capabilities:

- It generates statistically random patterns of 1's and 0's in synchronism with an externally supplied train of clock pulses at clock rates up to 40 MHz. Eleven different pattern lengths, from 7 bits up to 1,048,575 bits, are selectable by a front-panel switch but a 36-pin connector gives full control over the pattern generating circuits, making possible programmed selection of over a million different sequences. Sequences longer than 1,048,575 bits can be obtained by chaining two or more PRBS Generators in series.
- It generates a sync pulse each time the pattern repeats. Though the patterns have all the statistical characteristics of randomness, they repeat exactly, eliminating statistical variations in repeated tests.
- It can compare its internally-generated sequence with an externally supplied sequence, generating an output pulse whenever they differ (Fig. 2).
- By a new technique, it quickly aligns its internal sequence with an external sequence, taking less than N bits for patterns $2^N - 1$ bits long.

- It can thoroughly scramble a digital data stream, generating a pattern of 1's and 0's that bears little statistical resemblance to the externally-supplied data stream (Fig. 4). It can then recover the original stream, either with a second 1930A at the receiving terminal of a transmission system or with the same 1930A processing a recording of the scrambled data. With the help of an external mixer (Fig. 5) it can scramble *analog* signals, spreading the analog information throughout the spectrum in a way that makes reassembly of the original analog signal difficult without prior knowledge of the code. The original signal can be recovered with another mixer and a 1930A duplicating the encoding sequence. The recovery process also dilutes the effect of any interference picked up during the transmission.

Pseudorandom Binary Sequence Generation

Linear sequential circuits consist of simple memory elements (flip-flops) and modulo-2 adders (also known as exclusive-OR gates, anticoincidence gates, or half-adders). With the proper feedback structure and initial conditions, and with no input, these circuits generate sequences with nearly ideal statistical characteristics.^{8,9}

A typical configuration is shown in Fig. 6. Feedback into the first stage depends on the states of stages 3 and 5 according to the truth table shown in the diagram. With five stages, this circuit generates maximal length sequences of 31 bits ($2^5 - 1$).^{*} When the initial state is 00001, the output¹⁰ is: 1000010010110011111000110111010.

Maximal length sequences can also be generated in

^{*} A maximal length sequence is one in which all combinations of N bits (except N zeroes) occur once and only once, N being the number of stages in the shift register.

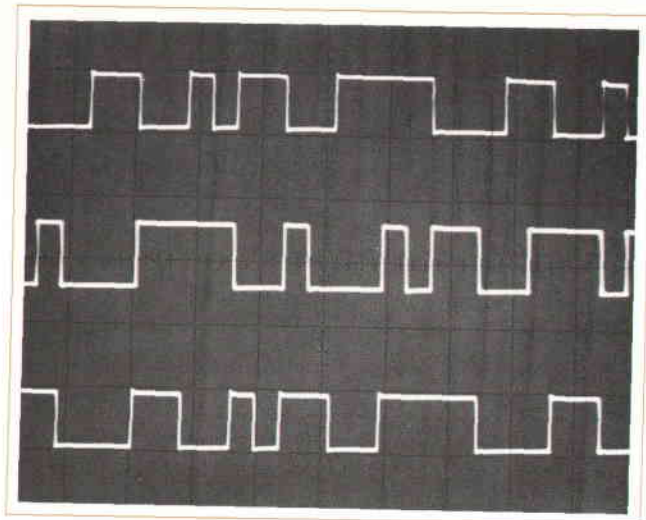

Fig. 4. Model 1930A scrambles input data stream (top trace) into apparently unrelated output stream (center trace). Original data stream is recovered with another 1930A (bottom trace) but is now delayed one clock pulse.

5-stage shift registers using feedback taps³ on these other cell combinations: 2 and 5; 2, 3, 4, and 5; 1, 3, 4, and 5; 1, 2, 3, and 5; and 1, 2, 4, and 5, as well as with the 3 and 5 combination of Fig. 6. These feedback combinations all generate sequences of the same length, 31 bits, but the digital patterns differ.

Certain sequences, e.g., $2^3 - 1$, $2^{12} - 1$, $2^{13} - 1$ and others, cannot be generated with only two feedback paths (Fig. 7). Multiple feedback paths can be effected through a modulo-2 adder tree that produces a 1 whenever there are 1's at an odd number of inputs. This is more easily done, though, with the circuit of Fig. 8, the dual of the circuit in Fig. 6. (Note the reverse numbering of stages required to preserve correspondence in the feedback pattern.) This arrangement, which allows switching feedback paths with logic gates, makes it possible to establish any feedback path easily. Furthermore, modulo-2 adders need never be connected in series so that pulse propagation delay is kept to a minimum, allowing operation at higher clock rates.

The 1930A uses this configuration in a 20-stage shift register. Besides the 73,080 different maximal length sequences possible with 20 stages, the 1930A, because of the control given over all possible feedback paths, can generate more than a million non-maximal sequences, a useful characteristic for cryptographic applications. It also works in a WORD mode, in which case it merely recirculates whatever digital word is loaded into it.

Processing Inputs

An additional capability is given the 1930A by provision for an input data stream, as shown in Fig. 9. The

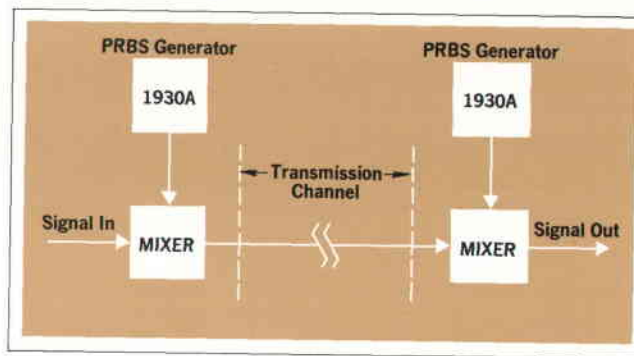

Fig. 5. Analog signal, when mixed with pseudorandom binary sequence, becomes thoroughly dispersed throughout spectrum but is recovered when mixed with identical sequence in second mixer. Interfering signals are dispersed throughout baseband signal spectrum by second mixer, reducing effect of interference.

interaction of the shift register with a stream of 1's and 0's applied through the input can be explained mathematically as follows:

A characteristic equation¹¹ for a shift register may be written with a transform operator, D , defined by the relationship:

$$X(t) = DX(t-1).$$

Multiplying by D is equivalent to a delay of one unit. Since time in a sequential binary circuit is variable only in units of clock time, D can have only two values: 1 or 0. For example, the sequence 11001 transforms into $1 + D + D^4$.

The transform can also be applied to the characteristic equation of a feedback shift register. For example, the circuit of Fig. 8 can be described, with the taps shown, by the transform $1 + D^3 + D^5$.

When used for division, the transfer equation for this shift register is:

$$H(D) = \frac{D}{1 + D^3 + D^5}.$$

The D in the numerator indicates that the output will be delayed one clock pulse with respect to the input. The sequence 11001 when applied to the shift register of Fig. 8 then becomes:

$$\begin{aligned} \phi(D) &= (1 + D + D^4) \frac{D}{1 + D^3 + D^5} \\ &= D + D^2 + D^4 + \dots + \text{ambiguous terms} \end{aligned}$$

which translates into the sequence 01101. (The initial 0 indicates the delay of one clock pulse.) This can be recovered by multiplying by the same register equation:

$$\begin{aligned} \phi_R(D) &= (D + D^2 + D^4) (1 + D^3 + D^5) \\ &= D + D^2 + D^5 \end{aligned}$$

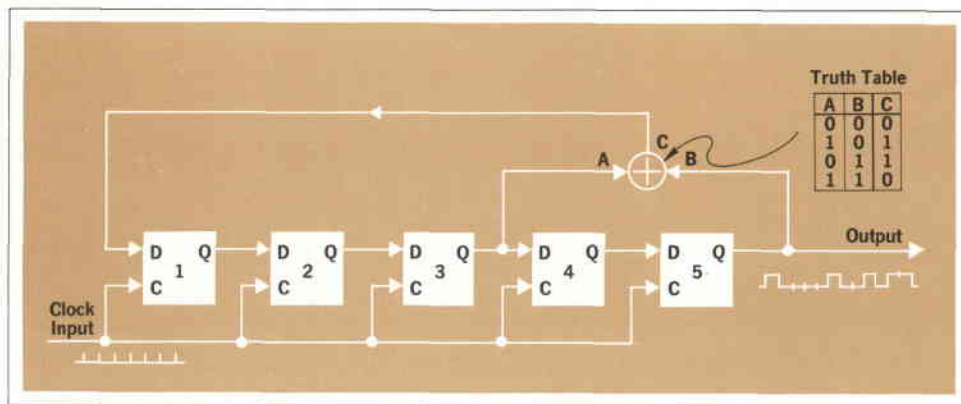

Fig. 6. Typical sequence-generating shift register. State of each stage is transferred to next stage on receipt of clock pulse. Feedback to stage 1 depends on states of stages 3 and 5.

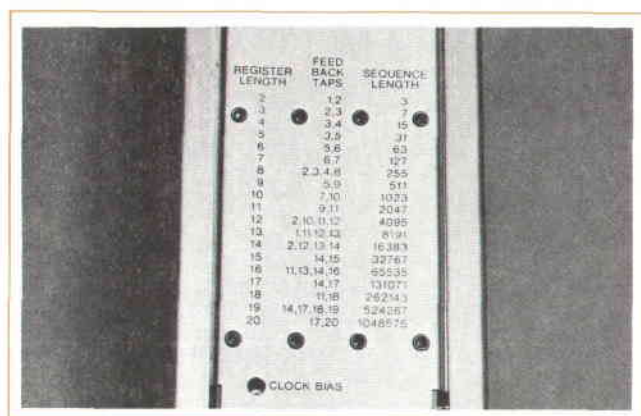

Fig. 7. Table of feedback taps for obtaining maximal length sequences is permanently imprinted on chassis for handy reference. Front-panel REGISTER LENGTH switch selects taps according to this table. Programming can be used for other tap arrangements.

which translates into 011001.

Thus, the encoding and decoding of a digital sequence is equivalent to dividing and multiplying the sequence by the characteristic polynomial of the shift register.

As an example of the effectiveness of this technique for cryptography, consider the sequence:

00101110010111001011

When divided by $1 + D^3 + D^5$, the result is:

10000011010111110100

These two sequences are alike in 9 bits and different in 11 bits. Hence, the cross-correlation is -0.1 over the 20-bit interval indicating that the two are statistically almost unrelated.

Division is performed by the 1930A when the shift-register operates in the feedback mode, as in Fig. 9. Multiplication is performed when the instrument is switched to operate in a feed-forward mode in which the feedback path is interrupted and the input is fed to the tap line. This capability, hitherto unavailable in a

commercial instrument, is also diagrammed in Fig. 9.

A useful characteristic of the multiply or feed-forward mode is that the state of the shift register very quickly aligns itself with an incoming data stream. Alignment of the register used for decoding is thus automatic.

The usefulness of the 1930A for cryptographic purposes is enhanced by its ability to be chained in series with other 1930A's. Longer sequences are derived simply by making the output of one generator the input of the next.¹² The resulting pattern length is the multiple of the lengths of the individual patterns provided that the patterns are relatively prime (contain no common factors). The longest sequence possible with two 1930A's is $(2^{20} - 1)(2^{19} - 1)$ or about 0.5×10^{12} bits.

The Inside Story

A block diagram of the 1930A is shown in Fig. 10. In the NORM mode, the shift register operates in the feedback mode with the feedback configuration selected by switches $K_1 \dots K_{20}$. These are operated either by the front-panel switch through a diode matrix or directly by external commands (switch closures to ground or T²L logic levels). The NORM mode actually is the divide configuration with the input to the shift register forced to zero.

Data streams applied to the input are added modulo-2 to the shift register output. Any 1's resulting from a difference in the two streams appear at the ERROR output.

Pressing the DATA SYNC pushbutton switches the register to the MULTIPLY mode allowing the input stream to load the register. This is much faster than previous alignment techniques in which the shift register is stopped until the incoming sequence matches the current contents of the register. The MULTIPLY technique has a further advantage in that no errors are introduced if DATA SYNC is initiated mistakenly after the register is already in sync.

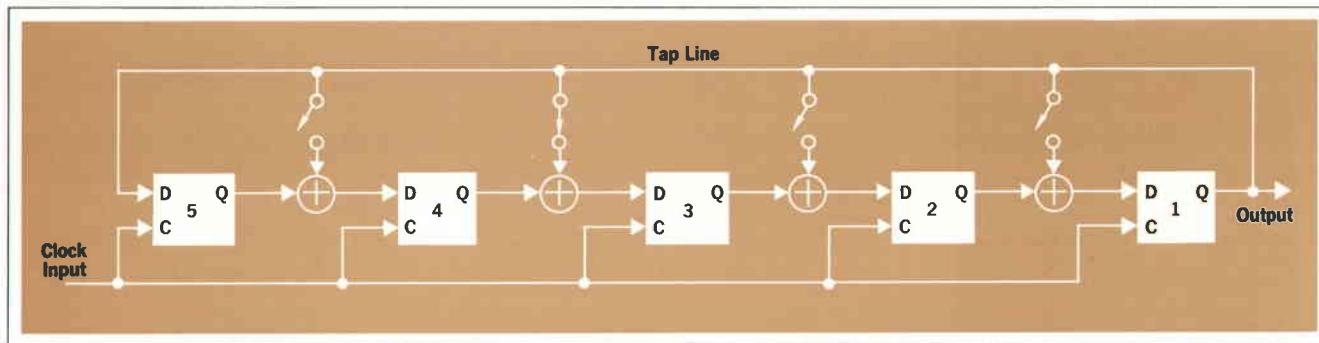

Fig. 8. Shift register configuration that facilitates full control of feedback configuration. This one generates patterns identical to patterns generated by circuit of Fig. 5.

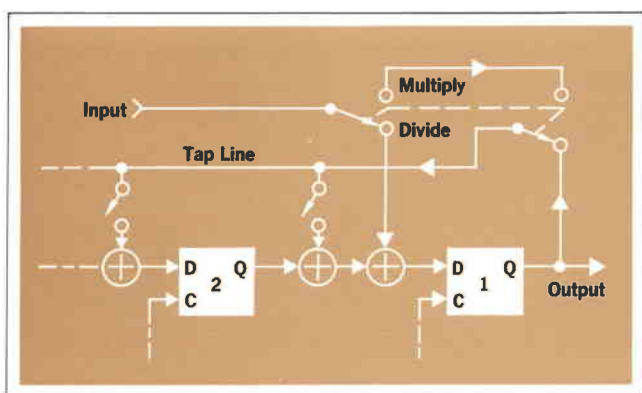

Fig. 9. Data stream introduced into shift register through modulo-2 input is divided by characteristic digital equation of shift register. When data is introduced into tap line, it is then multiplied by shift register equation.

A TRIGGER output is generated each time the register state is 000 . . . 001, as sensed by a detector that determines when all stages except stage 1 are in the zero state. If it should ever happen that stage 1 were also in the zero state—a condition that would stop sequence generation—then a 1 is automatically loaded into stage 1 through the 'Start' AND gate.

In the DIVIDE mode, the shift register configuration remains the same as for NORM but the input is added into the first stage. In the MULTIPLY mode, the input drives the tap line and the output is taken from the modulo-2 addition of the input and the shift register output. The incoming sequence automatically loads into the shift register so that in N digits or fewer, both transmitting and receiving registers will contain the same digits and will thus be in synchronism (N is the shift register length). In general, the transmitter and receiver do not have to have the same circuit—it is only necessary for the characteristic equations to be the same (characteristic equations selected by the 1930A's front-panel REGISTER LENGTH switch match those of the HP Model 3722A Pseudorandom Noise Generator and the Model 1925A Word Generator). With programming, the 1930A can match the characteristic equation of any linear sequential circuit of 20 stages or fewer.

The 1930A formats output information in two forms: return-to-zero (RZ) and non-return-to-zero (NRZ). When switched for RZ, the output is a train of 0 and 2V pulses, each 2V pulse being 10 ns wide. In the NRZ format,

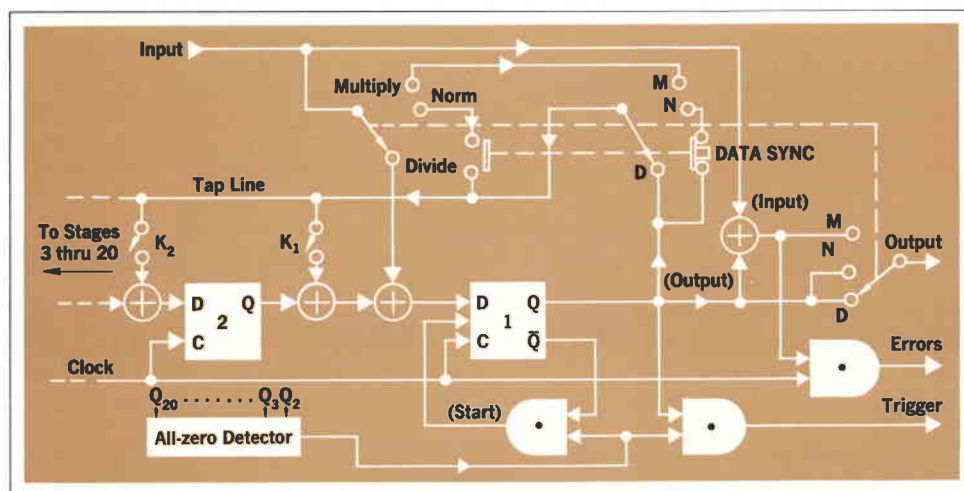

Fig. 10. Simplified block diagram of Model 1930A PRBS Generator.

SPECIFICATIONS

HP Model 1930A PR Binary Sequence Generator

CLOCK INPUT

REPETITION RATE: 0 to 40 MHz (to 50 MHz typically in most sequences).

INPUT R: 50 ohms, dc-coupled.

AMPLITUDE: +1 V min to 5 V.

WIDTH: Between 4 and 15 ns.

PROPAGATION DELAY: 40 ns max (clock input to output transition).

DATA INPUT

REPETITION RATE: 0 to 40 MHz (to 50 MHz typically).

INPUT R: 50 ohms, dc-coupled

AMPLITUDE

ONE LEVEL: +1 V min to 5 V.

ZERO LEVEL: 0 V to -5 V.

PRBS OUTPUT

AMPLITUDE: 45 ±5 mA or >2 V into 50 ohms.

RISE AND FALL TIMES: <4 ns.

WIDTH (in RZ mode): >9 ns, <50% of period.

SOURCE R: Underminated current source.

ERROR OUTPUT

AMPLITUDE: 45 ±5 mA current source or >2 V into 50 ohms.

WIDTH: >10 ns; <50% of period in RZ mode.

SOURCE R: Underminated current source.

SELF GENERATED ERROR RATE: <1 × 10⁻¹².

PROGRAMMING INPUTS (Requires Option 001 1900A or 1901A Mainframes).

FALSE: Contact closure to <0.6 V.

TRUE: Open or >3.0 V.

RESPONSE: <300 ns.

THRESHOLD: Approx. 2.2 V or 5.5 k ohms.

GENERAL

DIMENSIONS: Quarter-size module 3¾ in wide, 4¾ in high (95,25; 117,48 mm) for 1900A and 1901A mainframes.

WEIGHT: Net, 2¼ lb (1,02 kg); shipping, 4½ lb (2,04 kg).

POWER: Supplied by 1900A mainframe (up to two 1930A's) or 1901A mainframe (up to four 1930A's).

PRICE: Model 1930A, \$1200.

MANUFACTURING DIVISION: COLORADO SPRINGS
1900 Garden of the Gods Road
Colorado Springs, Colorado 80907

the output remains at the 2V level continuously as long as a string of 1's occurs, returning to the baseline level when 0's occur.

Other pulse amplitudes (up to 50V and 1 amp) can be obtained with output modules available in the 1900 Pulse Generator series.¹³ These modules, which also operate in either RZ or NRZ formats, have baseline offset and controllable transition times for shaping the binary sequences to meet the demands of intended applications. Other modules in the 1900 system supply clock pulses and clock pulse delays.

Acknowledgments

Mechanical design and production planning for the Model 1930A PRBS Generator were the responsibilities of Albert C. Knack. The author is also indebted to engineers at Hewlett-Packard Ltd, Scotland, for a week of stimulating discussions on linear sequential circuits, especially Brian Finnie, Anthony Annis, and Stephen Hodge who helped get the 1930A project under way. 

References

- (1). Bartee, T. C., and Wood, P. W., 'Coding for Tracking Radar Ranging', MIT Lincoln Laboratory, FSTI No. AD416 649, June 1963.
- (2). J. E. Savage, 'Some Simple Self-Synchronizing Digital Data Scramblers', Bell System Technical Journal, February 1967.
- (3). W. W. Peterson, 'Error-Correcting Codes', The MIT Press, Cambridge, Mass., 1961.
- (4). Granino A. Korn, 'Random-Process Simulation and Measurements', McGraw-Hill, 1966.
- (5). G. C. Anderson, B. W. Finnie and G. T. Roberts, 'Pseudo Random and Random Test Signals', **Hewlett-Packard Journal**, Sept. 1967.
- (6). E. S. Donn, 'Generating Words for Digital Testing', **Hewlett-Packard Journal**, April 1969.
- (7). F. H. Lange, 'Correlation Techniques', D. Van Nostrand, 1967.
- (8). Solomon W. Golomb, 'Shift Register Sequences', Holden-Day, Inc., San Francisco, Calif. 1967.
- (9). Bernard Elspas, 'The Theory of Autonomous Linear Sequential Networks', IRE Transactions on Circuit Theory, March 1959.
- (10). F. S. Donn, 'Linear Sequential Circuit Computer Simulation Program', **Hewlett-Packard Technical Memo**, Colorado Springs Division, Dept. 233, Colorado 80907.
- (11). D. A. Huffman, 'The Synthesis of Linear Sequential Coding Networks', Information Theory, C. Cherry ed., Academic Press, New York, 1956.
- (12). T. G. Birdsall and M. P. Ristenbatt, 'Introduction to Linear Shift-Register Generated Sequences', University of Michigan, Cooley Electronics Laboratory, Technical Report No. 90, October 1958.
- (13). G. K. Blanz and R. L. Knauber, 'A New Programmable, Building-Block Pulse and Digital System', **Hewlett-Packard Journal**, April 1969.

Edward S. Donn



Eddie Donn came to the Colorado Springs Division in 1966 after four years work with navigational, satellite communications, and ground support systems. A 1962 graduate of the University of Florida, Ed has been involved at HP in product planning for the 1900-series Pulse Generator plug-ins as well as contributing to the pulse-shaping circuits in the 1915A Output Module, developing the 1925A Word Generator, and now the 1930A PRBS Generator.

A determined mountain climber, Ed has climbed the Matterhorn (the original in the Alps, that is) and 25 of Colorado's over-14,000 foot peaks. He also practices target shooting and helped the HP Sportsman's Club win a first place trophy in last winter's pistol competition.

How to Make a Nuclear Spectrum Hold Still

It's simple with this new digital spectrum stabilizer.

By Steven Upshinsky

MULTICHANNEL ANALYZERS are sophisticated electronic instruments used primarily to identify radioactive materials and measure their activities. They do this by measuring the energies of the particles and photons emitted by such materials (see last month's issue). No two materials emit particles and photons with exactly the same energies.

Although alpha, beta, and X-rays are often of interest, by far the majority of multichannel analyzer applications are in gamma-ray spectroscopy. When a gamma-emitting sample is analyzed, the analyzer computes and displays the gamma-ray spectrum of the sample, a plot of the number of gamma-ray photons detected versus channel number, each channel corresponding to a certain photon energy. A typical spectrum, like that of Fig. 3, has a number of peaks in it. The peaks are located at the characteristic energies of the photons emitted by the radioactive constituents in the sample.

There are certain types of analyses that severely challenge nuclear instruments' abilities. A good example is looking for radioactive pollutants in the atmosphere. Atmospheric samples typically contain many different radioactive materials, but in amounts so minute that to gather enough data to identify and quantify all the materials, a multichannel analyzer must often count photons for days or weeks. In any experiment that lasts so long the stability of the instrumentation is a critical factor. Age, temperature, humidity, and other factors affect the characteristics of electronic devices. Over any long period of time, or when subjected to drastic environmental changes, an electronic instrument may drift, or change its characteristics, enough to affect the accuracy of an experiment.

In a nuclear pulse-height-analyzer system, which con-

sists of a radiation detector (either a high-resolution semiconductor type or a scintillation type) and electronic amplifiers as well as a multichannel analyzer, drift from various sources can cause the peaks in the measured spectrum to broaden and become distorted. Even with careful temperature control, say to within 2°C, drift over a long period could amount to five channels in 8192, assuming typical parameters. This amount of drift would cause significant errors in calculations as well as distortion of the spectrum. Consequently, in long experiments or when environmental changes are unavoidable, some form of drift compensation is required to keep the measured spectrum calibrated at all times.

Spectrum Stabilizer

A new digital spectrum stabilizer, Model 5586A (Fig. 1) can compensate for all types of drift likely to cause trouble in multichannel-analyzer systems, including drift in the nuclear-detector electronics and in the analog-to-digital converter of the analyzer itself. Fig. 2 shows how the stabilizer fits into a system.

In operation, the stabilizer monitors the digital data coming out of the analog-to-digital converter. The stabilizer is connected in parallel with the analyzer's data processor, so normal analyzer operation is not interrupted. In the stabilizer are two identical sections. One checks for baseline drift, or changes in the lowest channel's energy, and the other checks for changes in the gain, or overall scale factor, of the system. If any drift is detected the stabilizer generates a dc voltage proportional to the drift and applies this voltage to the correction element in the analog signal path. The correction element is a dc amplifier with voltage-controllable gain and dc offset. The correction voltage changes the gain

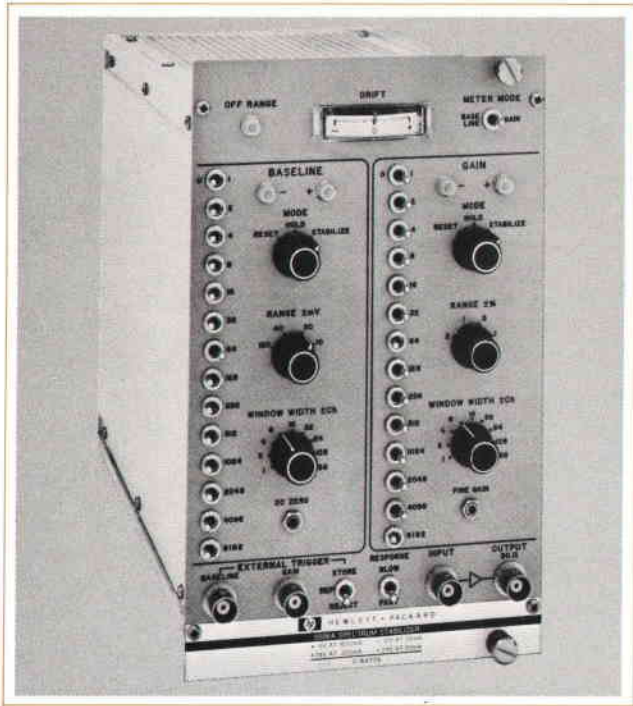

Fig. 1. Model 5586A Spectrum Stabilizer compensates for electronic drift which can cause distortion in gamma-ray spectra. The stabilizer has a built-in correction element and is easy to operate.

or offset of the amplifier, thereby compensating for the drift.

To detect drift the stabilizer must have a reference. Peaks in the spectrum provide this reference. The energies of these peaks are fixed by nature, so with the stabilizer in operation the system is inherently stable and

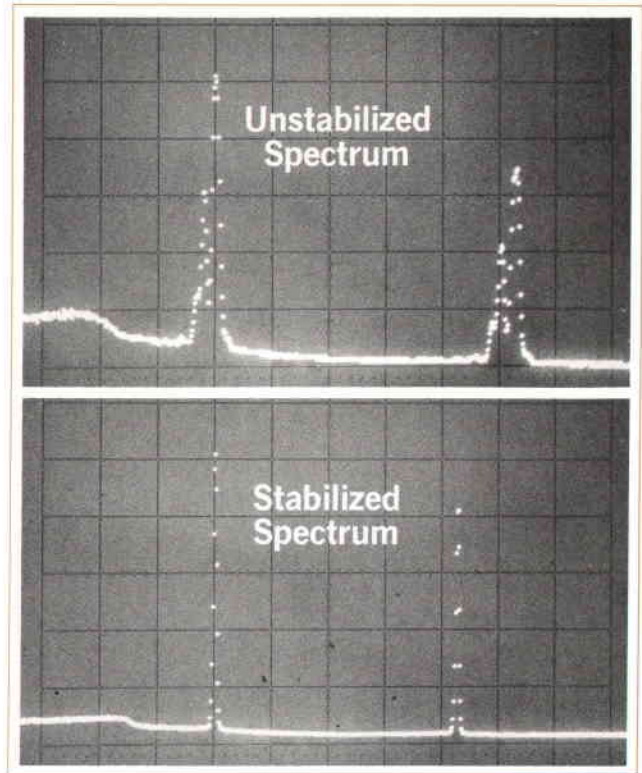

Fig. 3. Typical gamma-ray spectrum of a radioactive sample, showing the effects of spectrum stabilization.

doesn't require periodic recalibration against a standard. Any peaks can be selected as reference peaks, but normally a peak at the low end of the spectrum is selected as a baseline reference and one at the high end is selected as a gain reference. If the measured spectrum doesn't have convenient peaks a reference pulser can be

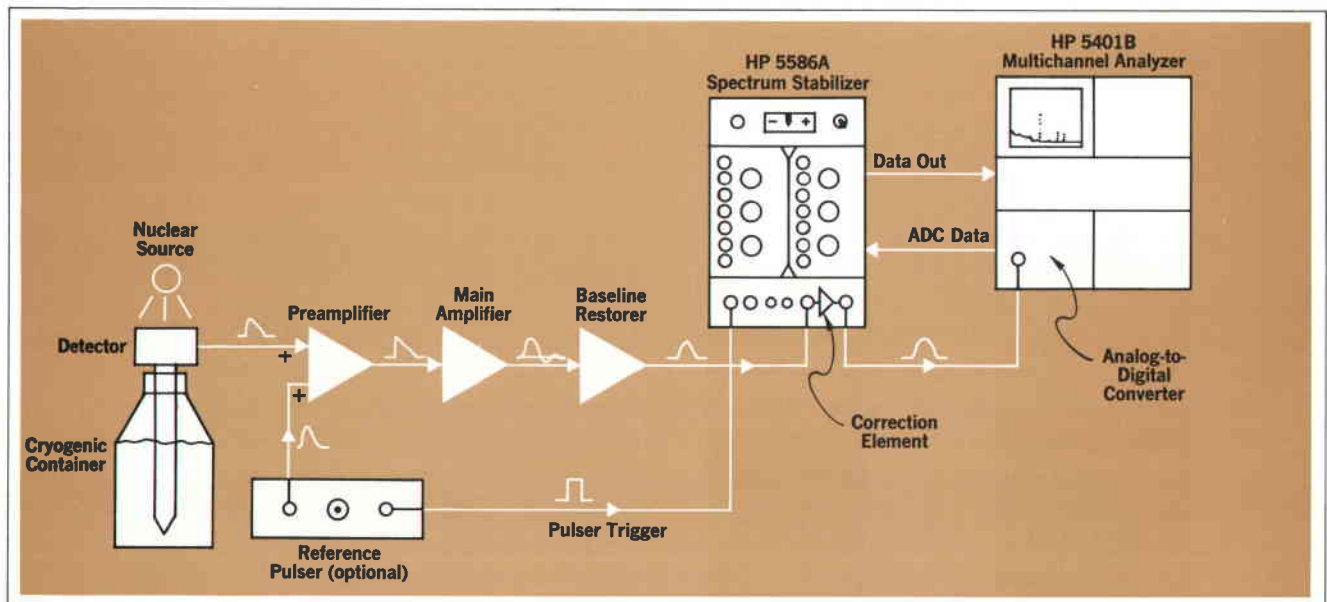

Fig. 2. A stabilized nuclear pulse-height analysis system. The reference pulser is used only if there are no suitable known peaks in the spectrum of the source.

used, as shown in Fig. 2. When the stabilizer is set up, the channel number corresponding to the center of each reference peak is set on the front-panel switches.

The results produced by the stabilizer are shown in Fig. 3, which compares a stabilized spectrum with an unstabilized one.

Easy To Use

The new stabilizer is designed to be easy to set up and use. Unlike some similar instruments the HP 5586A has

SPECIFICATIONS

HP Model 5586A Spectrum Stabilizer

STABILIZER PARAMETERS

BASELINE RANGE: ± 120 mV, ± 40 mV, ± 20 mV, ± 10 mV, selectable.
BASELINE CORRECTION INCREMENT: Range/512.
GAIN RANGE: $\pm 2\%$, $\pm 1\%$, $\pm 0.5\%$, $\pm 0.1\%$ of full scale, selectable.
GAIN CORRECTION INCREMENT: Range/512.
PEAK LOCATIONS: Selectable from 0 to 16,384 in single-channel increments, for both baseline and gain.
WINDOW WIDTH ABOUT PEAKS: ± 1 , ± 2 , ± 4 , ± 8 , ± 16 , ± 32 , ± 64 , ± 128 , ± 256 channels, selectable, for both baseline and gain.

CORRECTION ELEMENT (dc amplifier)

GAIN: $X1 \pm 5\%$.
NOISE: $< 100 \mu\text{V rms}$.
INTEGRAL NONLINEARITY: $< \pm 0.05\%$.
OUTPUT BASELINE: (dc zero) Controlled by Baseline Stabilizer, front panel adjustable over ± 8 mV nominal range for setup.
OUTPUT GAIN: Controlled by Gain Stabilizer, front panel adjustable over $\pm 0.2\%$ nominal range for setup.

INPUTS

ANALOG INPUT: $Z_{in} = 500 \Omega$, ± 10 V FS, ± 12 V max, dc coupled.
DIGITAL INPUT (BINARY): 14 lines, TTL levels, high = true.
EXTERNAL TRIGGER: $+3$ V to $+12$ V pulses, $10 \mu\text{s}$ wide.

OUTPUTS

ANALOG OUTPUT: $Z_{out} = 50 \Omega$, ± 10 V max into 500Ω .
DIGITAL OUTPUT (BINARY): 14 lines, TTL levels, high = true.
RECORDER OUTPUTS: Proportional to drift meter deflection.
BASELINE: ± 5 V Full Scale.
GAIN: ± 5 V Full Scale.

INDICATORS:

DRIFT METER: Selectable between Baseline or Gain.
OFF RANGE LIGHT: Indicates that correction range has been exceeded.
BASELINE AND GAIN + AND - LIGHTS: Indicates position of each reference input with respect to selected peak centroid.

GENERAL

OFF-RANGE DATA SWITCH: Accept/Reject.
REJECT: Inhibits data transfer if system drift exceeds stabilizer range selected.
EXTERNAL TRIGGER REFERENCE: Store/Reject. Allows reference pulses to be excluded from stored spectrum.
RESPONSE: Fast/Slow.
FAST: Produces correction increment for every input within window.
SLOW: Reduces correction rate for slow drift conditions.
CONTROL: Internal or External control of stabilizer operation via remote connector, switch selectable.
TEMPERATURE RANGE: 0° to 55°C .
DIMENSIONS: Standard NIM 4-width module.
PRICE: \$2400.00
MANUFACTURING DIVISION: SANTA CLARA DIVISION
5301 Stevens Creek Boulevard
Santa Clara, California 95050

a built-in correction element. Besides adding convenience this minimizes loss of resolution, or broadening of the spectrum peaks, caused by noise injected into the analog-to-digital converter by the stabilizer. This effect, noticeable with many systems, is insignificant with the 5586A.

Front-panel lights, indicating which direction the data is drifting in relation to the switch-register setting, are helpful during initial setup, when the gain and baseline of the system must be adjusted so the reference peak falls in the desired channel. A 20-turn front-panel potentiometer on the stabilizer facilitates fine gain adjustments, and a similar potentiometer adjusts dc offset. These controls, along with the 'homing-in' characteristic of the closed-loop stabilization technique, make possible an energy calibration accuracy not attainable otherwise. Accuracies of one part in 40,000, or one-tenth channel in a 4096-channel spectrum, are easily achieved.

A front-panel meter indicates how much drift has occurred during an experiment. If the drift exceeds the compensation range set on the stabilizer's range switches, accumulation can be stopped to prevent the spectrum's becoming unstabilized; the user elects whether to stop or continue by setting a rear-panel switch. A front-panel light comes on if the drift exceeds the range.

Acknowledgments

I would like to thank Jim Doub and Jon Cross for their many helpful comments and suggestions during the course of the design. I also want to thank Tom Bendon for his effort in mechanical design and layout of the instrument.

Steven Upshinsky



Steve Upshinsky joined HP in 1969, just after receiving his BS degree from the University of California at Berkeley. His first project was the 5586A Spectrum Stabilizer. Now designing high-frequency counters at HP's Santa Clara Division, Steve is also working on his MS degree at near-by Stanford University. That leaves precious little time for anything else, but when a free moment does come along Steve is likely to use it for tennis, skiing, or building hi-fi components.

Astronomers Find Optical Timing Of Pulsars More Accurate

Measuring light pulses instead of radio pulses yields more accurate information about pulsar characteristics.

By Laurence D. Shergalis

SINCE THE DISCOVERY IN 1967 of stars that broadcast great amounts of pulsed radio energy, astronomers have been attempting to solve the mysteries of these sources of energy. These stars, called pulsars for pulsating radio sources, were discovered by radio astronomers. Many pulsars have since been identified by radio astronomy. Only one, located in the Crab Nebula, emits light visible on earth. All the others are 'seen' using radio astronomy techniques. Pulsar NP 0532 in the Crab Nebula emits strongly in the radio and visible regions, but relatively little energy in the microwave region. For about two years, a group of astronomers at Lick Observatory in San Jose, California have been monitoring its activity using optical techniques.

Optical timing of pulsar pulses yields greater accuracy than timing of radio pulses because light pulses travel at the speed of light. Radio pulses propagate at various rates slower than the speed of light, since they are subject to delays caused by free electrons occurring in gaseous clouds and other disturbances near the pulsar and in outer space. In addition optical pulses have a very regular shape; radio pulses do not. Also, radio pulses are more affected by noise. Therefore, arrival times of radio pulses must be corrected for these delays. To complicate matters, the correction is not always constant. A continual monitoring of other parts of the power spectrum is needed to determine the correction. All of these factors tend to make radio timing less accurate than optical timing.

For optical timing, the accuracy of the pulse arrival time depends only upon the number of photons observed, i.e. the length of time of observation. Arrival times approaching the basic limit of accuracy of the rubidium frequency standard used for timing can be reached in one night's observation.

With optical monitoring, errors in measuring pulse arrival time have been reduced to about 1 to 2 microseconds compared with about 10 to 20 microseconds error in radio pulse arrival times. Although optical observation is more accurate, it has its disadvantages. Weather and available telescope time limit optical observation. Also, as mentioned previously, only one pulsar has been found to be visible. Radioastronomical observations can be conducted without regard to weather, and all the other known pulsars emit signals only in the radio frequency region.

The principal variables studied in these experiments are the pulsar frequency and its derivatives. Pulsar NP 0532, according to observations by Chinese astronomers, was created by a supernova in 1054 AD. This makes it the youngest known pulsar, consequently it

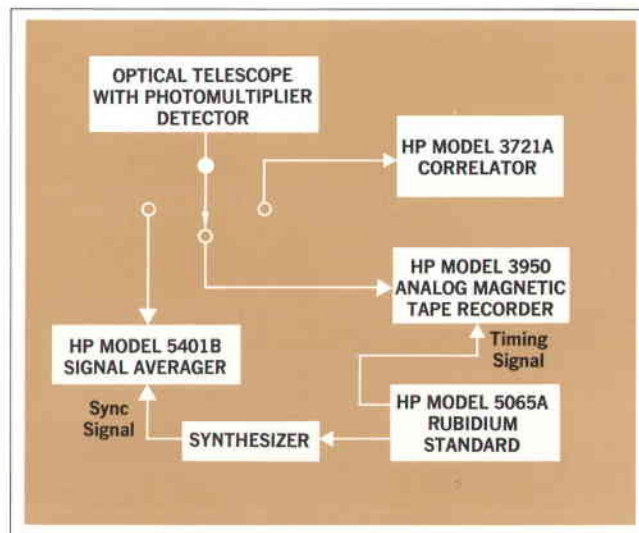

Fig. 1. Block diagram of instrumentation at Lick Observatory for pulsar measurements.

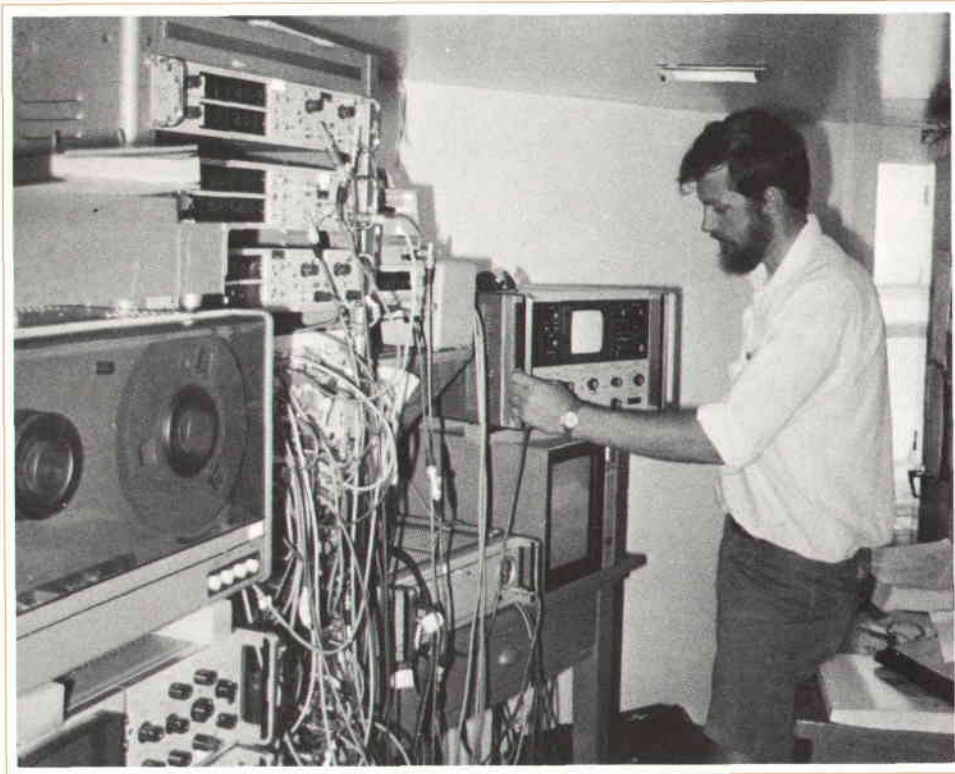

Fig. 2. University of California researcher sets up the HP Correlator in preparation for a night of measuring signals from the Crab Nebula Pulsar, and searching for signals from Supernova M101.

has the highest known rotation rate, about 30 cycles per second. Because the pulsar acts somewhat like a search light we see apparent pulsations as the light beam sweeps past the earth at the pulsar rotation frequency. It is considered the most interesting to watch both because of its youth and since it exhibits gradual and abrupt variations in frequency. While it slows smoothly about one part per million each day, it occasionally makes an abrupt change of about one part per billion. These sudden changes in frequency are interpreted as events occurring within the structure of the star. The complexity of the events that could take place indicate the need for continued and more accurate observations.

To detect photons emitted from the pulsar, a cooled photomultiplier is mounted at the prime focus of the 36-inch Crossley reflector telescope at Lick. The electrical pulses from its output are then averaged using a Hewlett-Packard 5401B Multichannel Averager. In order to perform this averaging with sufficient precision so as not to distort the data, the pulsar frequency must be known to 1 part in 10^9 . This frequency is set into a frequency synthesizer which generates the sync pulses for the averager. The pulsar frequency is known to this precision from previous measurements, and from knowledge that the pulsar changes its frequency rather slowly.

Since what is actually desired is the arrival time of

a pulse, extremely accurate timing must be done. An HP rubidium clock is used as the time base and as the frequency standard for driving the frequency synthesizer. This clock is calibrated regularly against HP's cesium clocks to insure the greatest possible precision.

Other optical pulsars are being looked for, but their frequency is, of course, not known. Thus other techniques must be used. An HP correlator can help find these unknown frequencies, but to search for pulsations with the greatest possible resolution the data must be recorded directly onto magnetic tape and later analyzed with a large computer.

Optical observation of NP 0532, using similar equipment, is also being conducted at Harvard and Princeton observatories in the United States. Work is aimed at unraveling the mysteries of all pulsars with these observations, and at attempting to find other optically visible pulsars.

Heading this project at the University of California at Berkeley is Jerry Nelson. John Saarloos is technologist for the project.

Bibliography

L. D. Shergalis, 'Stanford Scientists Study Space Signals,' **Hewlett-Packard Journal**, May 1968.

Charles N. Taubman, 'Pulsar Optical and Radio Emissions Observed Simultaneously,' **Hewlett-Packard Journal**, June 1969.

Programmable Step Attenuators Use Distributed-Thin-Film Attenuator Cards

New Programmable Step Attenuators employ a special transmission-line configuration with common outer conductors, so only center conductors need be switched.

By Stephen F. Adam

MORENO¹ DEFINES TRANSMISSION LINES AS a system of material boundaries forming a continuous path from one place to another and capable of directing the transmission of electromagnetic energy along this path. In wide-band practice at higher frequencies, where the principle mode (TEM) of transmission is used, coaxial structure is the type most commonly used. For quite some time standards have been established in coax. Connectors have been correspondingly standardized. Attenuators, as one of the basic building blocks of measurement systems, are developed to fit these standard transmission lines. With the advent of thin film technology, new types of attenuator realizations have come about, transforming the coaxial transmission line into a plane, allowing the use of precision thin film techniques.²

Some variable step attenuators are made in a turret arrangement³ employing fixed coaxial pads switched into a coaxial transmission line path. Highly sophisticated and quite difficult manufacturing techniques are necessary to attain long life and tight repeatability characteristics. Programmability was accomplished by motorizing such turrets.

In designing microwave coaxial step attenuators, the biggest concern has always been the mechanical difficulties involved in assuring repeatable, long-life switching. It is just naturally difficult to keep making a good contact simultaneously to an outer conductor and a center conductor in a coaxial structure while at the same time satisfying all the other mechanical and electrical constraints properly imposed on such a design. A coaxial switch has been described which is a transformed transmission line⁴, similar to a slabline, now called an edgeline. Edgelines having a thin center conductor, placed perpendicular between two parallel ground planes, con-

centrate the electric field to such an extent that high isolation switching is possible with *common* outer conductors. Furthermore, even moderately sharp bends on the center conductor shim will introduce only negligible discontinuities. The edgeline switches are driven with magnetically latching solenoids through plastic rods, guiding the flexible center conductor shims at the center between the ground planes where practically no electric field exists. The result is a switch with very low reflections, high repeatability, and extremely long life.

An attenuator scheme, used only at lower frequencies until now, works by switching between pads and bypass paths. Several of these sections in cascade form a quite versatile step attenuator (Fig. 1).

If one takes two switches, connecting the switched ports together in one arm with a precision coaxial attenuator pad, and in the other arm a straight-through bypass path, and then operate the two switches in tandem, there emerges a switchable attenuator with very respectable performance. If more of the same units are cascaded there emerges a nice design for a microwave programmable attenuator such as that illustrated in Fig. 2.

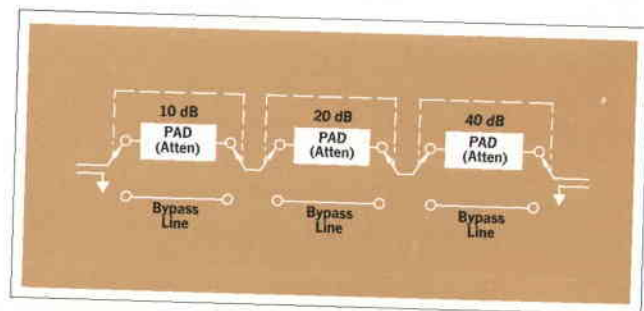

Fig. 1. Circuit arrangement of a cascaded type of step attenuator variable in 10 dB steps from 0 to 70 dB.

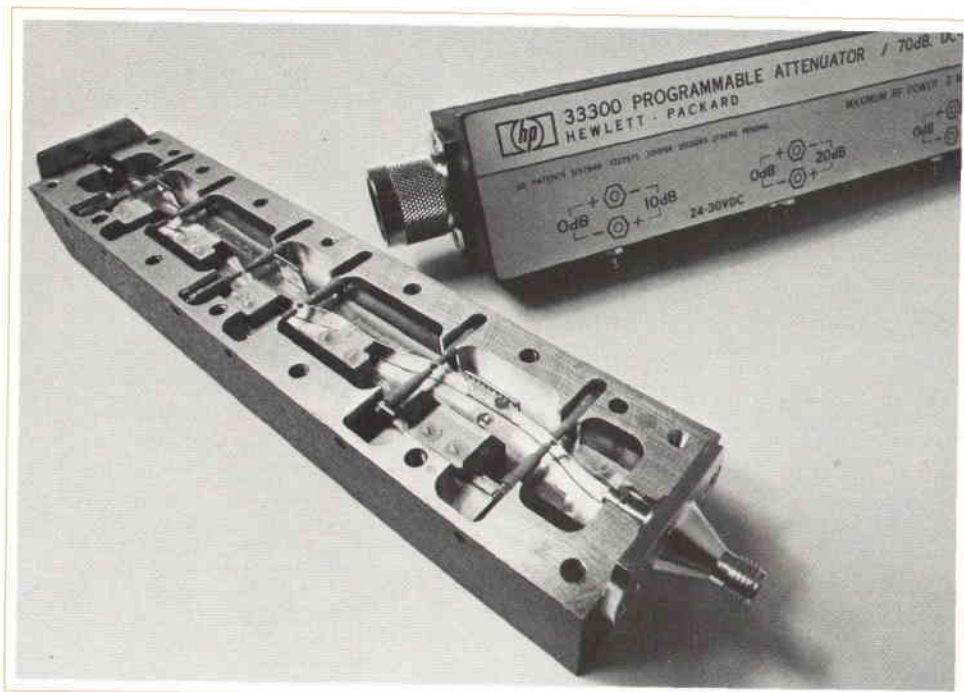

Fig. 2. Configuration requires only switching of center conductor to engage or bypass thin-film attenuator elements.

Transitions and internal connectors can be eliminated if all the attenuators and bypass paths are developed into edgeline configuration within one set of common ground planes. Now one comes up with a unique, high-performance programmable attenuator. Fig. 2 is a photograph of such an attenuator with three sections, one of 10 dB, one of 20 dB, and one of 40 dB part, comprising a 0–70 dB step attenuator in 10 dB steps. Other configurations are made, such as 0–110 dB in 10 dB steps, 0–11 dB in 1 dB steps, and 0–42 dB in 6 dB steps. Many others are, of course, possible.

All these attenuators cover the entire frequency range from dc to 18 GHz. The attenuator cards are newly developed, exploiting edgeline structure, using tantalum nitride thin film resistance elements on sapphire substrates, applying thin film technology. Frequency response is substantially flat and group delay is constant, even at the highest frequencies. High-temperature oxidation processing determines the desired sheet resistance of the tantalum nitride thin film, which contributes extraordinarily stable film resistivity.

Because the attenuator elements are stable, and because sliding contacts have been eliminated, excellent repeatability is achieved (typically <0.02 dB and $<0.1^\circ$ at 12 GHz) with high switching speed (<50 ms), long life (typically several million cycles), and compact size. The design even leads to low cost!

The solenoids driving the attenuator switches latch magnetically. 12 (A and C Models) or 24 volts (B and D Models) windings are supplied. The solenoids op-

erate upon reversal of the polarity of the applied dc voltage. Since the switches latch, energizing for approximately 30 ms is enough to switch. Some options include contacts for remote indication of the position of the switches (C and D Models). The design lends itself readily to fitting a wide variety of coax connectors, so all the common types are available options.



Fig. 3. Each attenuator undergoes tests for residual loss, reflection coefficient, and attenuation at each of a large number of frequencies from dc to 18 GHz. The full set of tests takes about 12 minutes on especially modified HP Model 8542 Automatic Network Analyzer equipment.

SPECIFICATIONS
HP Model 33300 Series
Programmable Attenuators

ELECTRICAL (All Units)
 FREQUENCY RANGE: DC to 18 GHz.
 CHARACTERISTIC IMPEDANCE: 50 Ω.
 RF INPUT POWER (Max): 2 W average, 500 W peak.
 POWER SENSITIVITY: 0.001 dB/dB/W.
 POWER REQUIRED TO SWITCH ONE SECTION: 3.3 W.
 SWITCHING SPEED (Max): 50 ms.
 SOLENOID VOLTAGE: 33300A/C - 12 to 15 volts.
 33300B/D - 24 to 30 volts.
 ATTENUATION TEMPERATURE COEFFICIENT: < 0.0001 dB/dB/°C.
 LIFE (Min): 1,000,000 steps each section.
ENVIRONMENTAL (All Units)
 TEMPERATURE, NON-OPERATING: -40°C to +75°C ambient.
 TEMPERATURE, OPERATING: 0°C to +55°C ambient.
 ALTITUDE: Operable at 25,000 feet.
 VIBRATION, NON-OPERATING: 10-55 Hz per min for 15 min on 3 planes at 0.010 in amplitude.
 SHOCK, NON-OPERATING: 30 G's on 6 sides, 3 blows.

HP Model 33300A/B/C/D
0 to 70 dB - 10 dB Steps

ATTENUATION ACCURACY:

FREQUENCY RANGE	Attenuator Setting (dB)				
	10	30	40	50	70
DC - 12.4 GHz	±0.5	±0.7	±0.9	±1.2	±1.5
12.4 - 18 GHz	±0.6	±0.8	±1.2	±1.6	±2.0

PRICE (1-9 quantities): 33300A/B, \$665.00; 33300C/D, \$690.00.

HP Model 33301A/B/C/D
0 to 42 dB - 6 dB Steps
(Tentative Specifications)

ATTENUATION ACCURACY:

FREQUENCY RANGE	Attenuator Setting (dB)					
	6	12	18	24	30	42
DC - 12.4 GHz	±0.4	±0.5	±0.7	±0.8	±0.9	±1.1
12.4 - 18 GHz	±0.5	±0.6	±0.8	±1.0	±1.2	±2.0

PRICE (1-9 quantities): 33301A/B, \$665.00; 33301C/D, \$690.00.

HP Model 33304A/B/C/D
0 to 11 dB - 1 dB Steps
(Tentative Specifications)

ATTENUATION ACCURACY:

FREQUENCY RANGE	Attenuator Setting (dB)										
	1	2	3	4	5	6	7	8	9	10	11
DC - 4 GHz	±0.2	±0.2	±0.3	±0.3	±0.3	±0.4	±0.4	±0.4	±0.4	±0.5	±0.5
4 - 12.4 GHz	±0.3	±0.3	±0.4	±0.4	±0.4	±0.5	±0.5	±0.5	±0.5	±0.6	±0.6
12.4 - 18 GHz	±0.4	±0.4	±0.5	±0.5	±0.6	±0.6	±0.7	±0.7	±0.8	±0.8	±0.9

PRICE (1-9 quantities): 33304A/B, \$900.00; 33304C/D, \$925.00.

HP Model 33305A/B/C/D
0 to 110 dB - 10 dB Steps
(Tentative Specifications)

ATTENUATION ACCURACY:

FREQUENCY RANGE	Attenuator Setting (dB)										
	10	20	30	40	50	60	70	80	90	100	110
DC - 12.4 GHz	±0.5	±0.7	±0.9	±1.2	±1.5	±1.8	±2.1	±2.4	±2.7	±3.0	±3.3
12.4 - 18 GHz	±0.6	±0.8	±1.2	±1.6	±2.0	±2.4	±2.8	±3.2	±3.6	±4.0	±4.4

PRICE (1-9 quantities): 33305A/B, \$900.00; 33305C/D, \$925.00.

	33300	33301*	33304*	33305*
INSERTION LOSS (max)				
DC - 8 GHz	0.8 dB	0.8 dB	1.0 dB	1.0 dB
8 - 12 GHz	1.2 dB	1.2 dB	1.5 dB	1.5 dB
12.4 - 18 GHz	1.8 dB	1.8 dB	2.4 dB	2.4 dB
REPEATABILITY (typical after 1,000,000 cycles)				
DC - 12.4 GHz	0.02 dB	0.02 dB	0.03 dB	0.03 dB
12.4 - 18 GHz	0.04 dB	0.04 dB	0.05 dB	0.05 dB
VSWR				
DC - 8 GHz	SMA, Type N, 7 mm: 1.35	SMA, Type N, 7 mm: 1.25	SMA, Type N, 7 mm: 1.5	SMA, Type N, 7 mm: 1.5
8 - 12.4 GHz	1.5	1.4	1.6	1.6
12.4 - 18 GHz	1.7	1.6	1.9	1.9

*Tentative Specifications

MANUFACTURING DIVISION: MICROWAVE DIVISION
 1501 Page Mill Road
 Palo Alto, California 94304

Acknowledgments

The author is grateful to David R. Veteran, who is actually carrying out the development of these programmable attenuators.

The following patents cover these attenuators: 3,319,194; 3,500,263; 3,157,846; 3,227,975; 3,521,201; 3,543,197.

References

1. T. Moreno, **Microwave Transmission Design Data**, Dover Publications, Inc., New York.
2. Stephen F. Adam, 'Precision Thin-Film Coaxial Attenuators', **Hewlett-Packard Journal**, June 1967, pp. 12-19.
3. Stephen F. Adam; **Microwave Theory and Applications**, Prentice-Hall, Inc., 1969, pg. 360.
4. Stephen F. Adam, G. R. Kirkpatrick, R. A. Lyon, 'Broadband Passive Components for Microwave Network Analysis', **Hewlett-Packard Journal**, January 1969, pp. 2-10.

Stephen F. Adam



Steve Adam was a research and development engineer in Budapest, Hungary before he joined HP in 1957. At HP, Steve has supervised the development of coaxial wavemeters, thin-film coaxial attenuators, and coaxial switches. Steve is Chief Microwave Engineer, which includes managing a technical staff section. He holds several patents and has others pending, mainly in the fields of transmission-line components and microwave instrumentation. Steve holds

European degrees on the Master's level in both mechanical and electrical engineering.

Steve is chairman of the IEEE-GMTT Waveguide Measurements Committee. He is a member of both GMTT and HFIM Standards coordinating committees and several connector standardization committees. He has recently been named the secretariat to the International Electrotechnical Commission (IEC) Technical Committee #66 Fifth Working Group, dealing with microwave measurements.

Steve is the author of numerous papers and the textbook, 'Microwave Theory and Applications,' Prentice-Hall, Inc., 1969.

HEWLETT-PACKARD JOURNAL APRIL 1971 Volume 22 • Number 8

TECHNICAL INFORMATION FROM THE LABORATORIES OF HEWLETT-PACKARD COMPANY 1501 PAGE MILL ROAD, PALO ALTO, CALIFORNIA 94304 U.S.A.
 Hewlett-Packard S.A. 1217 Meyrin - Geneva, Switzerland • Yokogawa-Hewlett-Packard Ltd., Shibuya-Ku, Tokyo 151 Japan

Editor: R. H. Snyder Editorial Board: R. P. Dolan, L. D. Shergalis Art Director: Arvid A. Danielson Assistant: Maridel Jordan

HP Archive

This vintage Hewlett-Packard document was
preserved and distributed by

www.hparchive.com

Please visit us on the web!

On-line curator: John Miles, KE5FX

jmiles@pop.net

