

HEWLETT-PACKARD JOURNAL

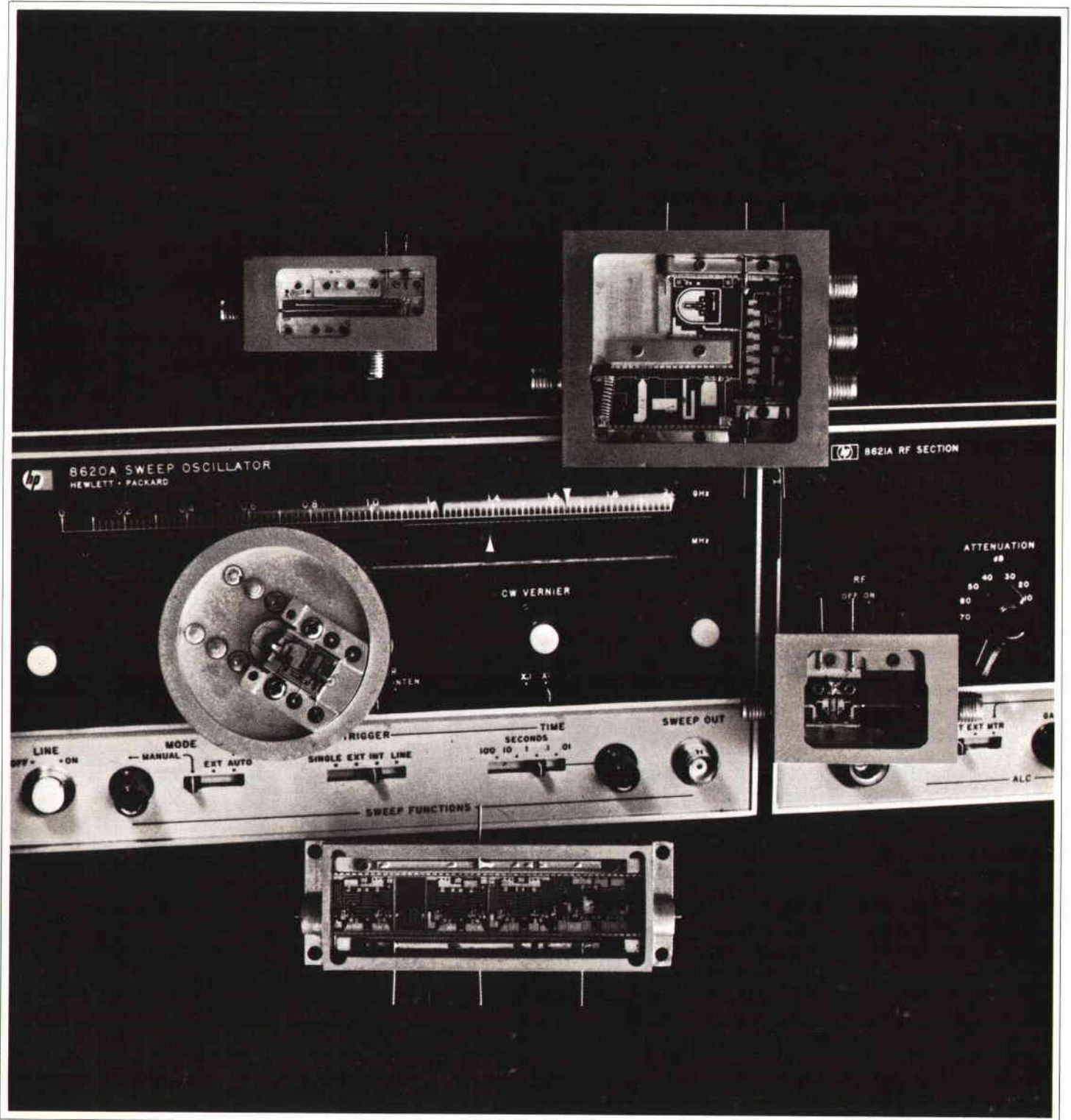

NOVEMBER 1970

Sweeping the Microwave Spectrum With Solid-State Sources

By Robert H. Bathiany, Carl J. Enlow, Phillip G. Foster
and Stephen Vitkovits

PRESENT DAY MICROWAVE SWEEPERS usually consist of a mainframe and an rf plug-in. Contained in the mainframe are such circuits as power supply, sweep circuit and control functions. The plug-in contains the rf components. In the past this normally included a backward wave oscillator tube, a modulator for leveling and amplitude modulation, and in some cases a directional detector for internal leveling. This arrangement is economical and flexible, since a new mainframe need not be purchased each time a new frequency band is needed. Further to increase the utility of the mainframe and plug-in arrangements, rf unit headholders hold several rf plug-ins, all controlled by one plug-in mainframe. Although they provide a wide frequency range, these mainframes and rf head holder arrangements are large, heavy, and somewhat inconvenient to use. With this in mind, the objectives of the HP design group which undertook a new solid-state microwave sweeper included building an instrument that would feature easily-expanded multiband coverage without separate headholders, while remaining easy to use.

Convenient multiband coverage is important because more and more engineers find their work involves a broad frequency range. Since sweepers find use not only in the laboratory, but on the production line and in maintenance as well, it was important to provide an operating format that would suit many needs. For maintenance uses it was important that a new sweeper be housed in a small and easily transported cabinet. Often it is necessary for the technician to carry the instrument into such difficult-to-reach locations as the top of a microwave tower, or through a submarine hatch. To achieve longer life and less power consumption, another objective for the 8620A was the use of *all* solid-state cir-

cuits. To top it all off, the project aimed at improved serviceability and reliability.

So the 8620A (Fig. 1) might be an economical high-performance sweeper for both the single and multi-frequency band user, a new system was evolved. First, all the common non-rf circuits were separated from the actual signal generating components. This resulted in a mainframe which, in the simplest terms, exists to supply the rf oscillators with dc power and a sweep tuning voltage. All other mainframe features may be considered as embellishments on this simple theme. This does not impute a subordinate role to the mainframe (Fig. 2); many of the important specifications are determined



Cover: The rf elements are all-microcircuit in the solid-state microwave sweeper to which this entire issue is devoted. Shown in front of the sweeper on our cover (left to right and top to bottom): the directional detector, the frequency converter module, the 2-4 GHz YIG oscillator, the PIN absorptive modulator, and the 0.1-2 GHz amplifier.

In this Issue:

Sweeping the Microwave Spectrum with Solid-State Sources, by Robert H. Bathiany, Carl J. Enlow, Phillip G. Foster and Stephen Vitkovits **page 2**

Microcircuits for the Microwave Sweeper, by Ronald E. Pratt, Robert W. Austin and Arlen Dethlefsen **page 9**



Fig. 1. Solid-state design and microcircuitry make possible multi-octave swept microwave signal generation with a single mainframe only 5¼ inches high.

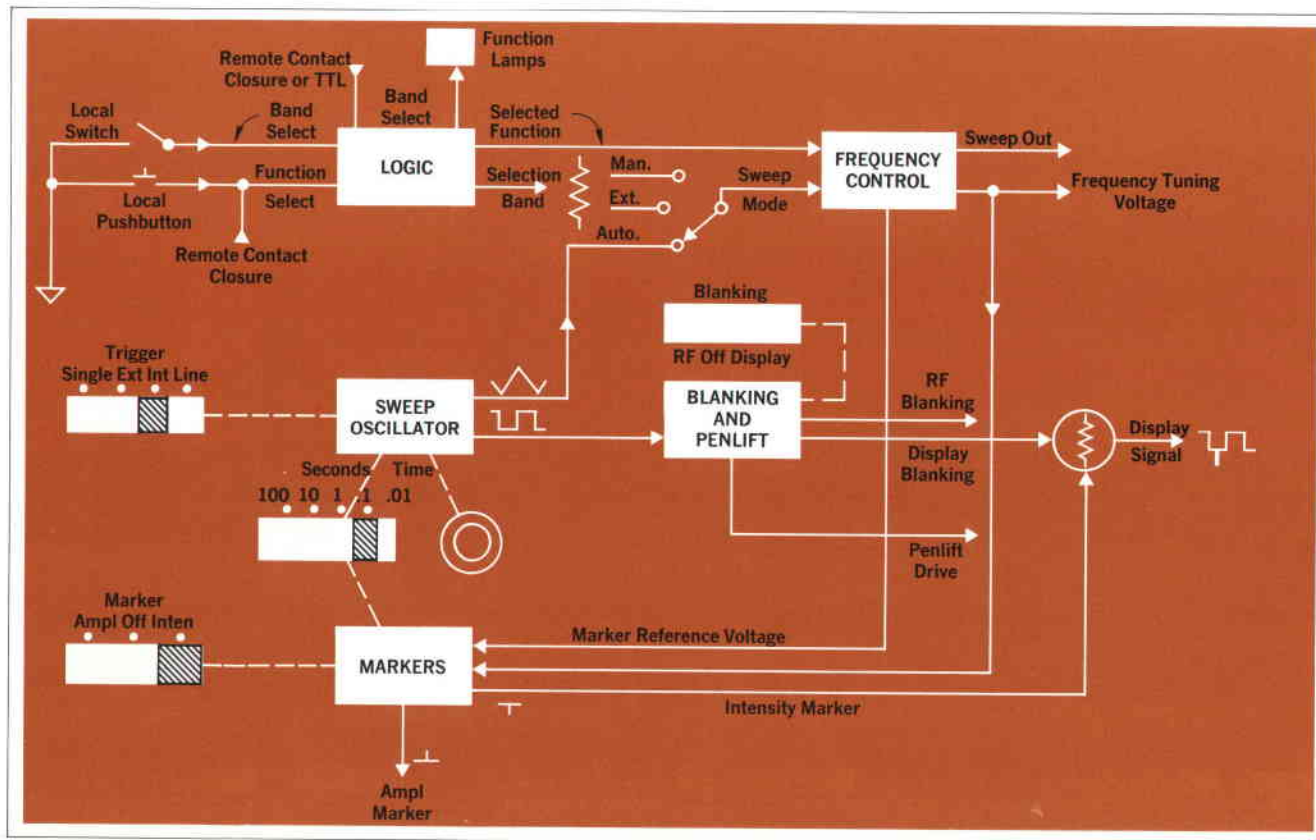

Fig. 2. Block diagram of mainframe.

here, and the embellishments are expanded capabilities today's needs demand. For example, logic circuits commanded by local or remote contact closures determine the operating band and the sweep function. The band information is used in the rf drawer to activate the appropriate module, while the sweep function information is used in the mainframe to select the proper frequency control circuits to set START and STOP limits for the tuning voltage.

A sweep control oscillator in the mainframe generates two signals: 1) the basic sweep ramp, which is modified by the frequency control circuits so as to become a 0 to +10 sweep-tuning voltage with end points individually adjustable between 0 and +10 volts, and 2) a timing signal to drive the blanking and pen-lift circuits. Marker circuits generate both a positive and a negative pulse as the frequency-tuning voltage crosses a reference voltage determined by the SW/MARKER front panel control. The positive pulse can be used to amplitude-modulate the rf output; the negative pulse is summed with the display blanking signal to intensity-modulate a display unit. There is also in the mainframe a 1-kHz square-wave oscillator to be used as an internal source for rf amplitude modulation. A rear panel switch on the mainframe selects internal or external modulation. There are four regulated power supplies, each with crowbar overvoltage protection. Circuits are optional to make up to 1000 discrete frequencies remotely programmable.

The rf components making up the signal-generating portion of the sweeper were arranged so that a single-band instrument could, 1) easily be made multi-band; 2) contain internal multiplexing of the output; 3) provide for options such as internal leveling, internal attenuation (above and beyond that provided by the level control), and deliver power output at the rear of the instrument. These requirements were met by employing a drawer, which in one sense can be considered to be a removable extension of the mainframe, into which oscillator modules are installed. The drawer is completely *frequency independent*, that is, it simply acts as a coupler between the mainframe and the plug-in modules. The 8621A drawer also holds the automatic level control (ALC) and attenuator control circuits.

For any given frequency range, the line-up of rf components consists of a wide-band, electrically-tunable oscillator, a modulator for leveling and AM, and a directional detector for internal leveling. Some of these components have a broader frequency range than others, thus offering many ways to interconnect the components for multi-band operation. On one hand there is a desire

to use each component to its fullest, and on the other to have simple rf switching. All this considered, the oscillator modules were designed to contain the oscillator, modulator, and as an option a directional detector. Thus the module became a complete rf system and offers great flexibility with respect to frequency bands. Further, this arrangement simplified the modulator and directional detector design since maximum performance is required only for an octave or less, e.g. 2-4, 4-8, 8-12 GHz, etc. At present, oscillator modules exist for frequencies from 0.1 to 4.2 GHz only. Commitment is firm, however, for modules covering the bands from 4 to 18 GHz. The rf output of each module is connected to a multi-position rf switch to route the output to the front or rear panel. Also contained in the module are the tuning current drive, FM, and control circuits.

The use of plug-in modules allows the 'custom building' of rf sections to meet the user's own frequency coverage requirements. Modules may be changed in minutes as they are fastened with only four screws and one SMA rf connector. The lid of each module functions as an extractor making it easy to remove the module from the rf drawer.

Each fundamental oscillator module contains a voltage-tuned oscillator, PIN modulator, and optional directional detector for internal leveling. Also included is the tuning voltage driver, FM driver, and ALC circuitry directly related to that particular module (Fig. 3).

The tuning voltage driver converts the 0 to +10 volt tuning ramp from the mainframe to the required current to tune the oscillator. This stage also contains lead compensation to compensate for frequency offset when in the fastest sweep mode. In the case of the 8633A 2-4 GHz module, this driver must be capable of inverting or not inverting the tuning voltage ramp, depending upon whether the 2-4 GHz or the heterodyned 0.1-2 GHz modules is used. When sweeping the heterodyne output from 0.1-2 GHz, the fundamental 2-4 GHz oscillator must sweep from 4.2 to 2.3 GHz as it is being mixed with a 4.3 GHz local oscillator.

The FM circuitry may be used in various modes which are selected by a switch on the back of the rf drawer. When the FM mode is used, input sensitivity is 20 MHz/V. This high gain is very convenient when using large frequency deviations. With the selector switch in the Phase Lock mode, the gain is decreased so as to be compatible with the 8709 synchronizer. Since the sensitivity required by the 8709 depends upon the frequency band used, this gain adjustment is automatically made within each module.

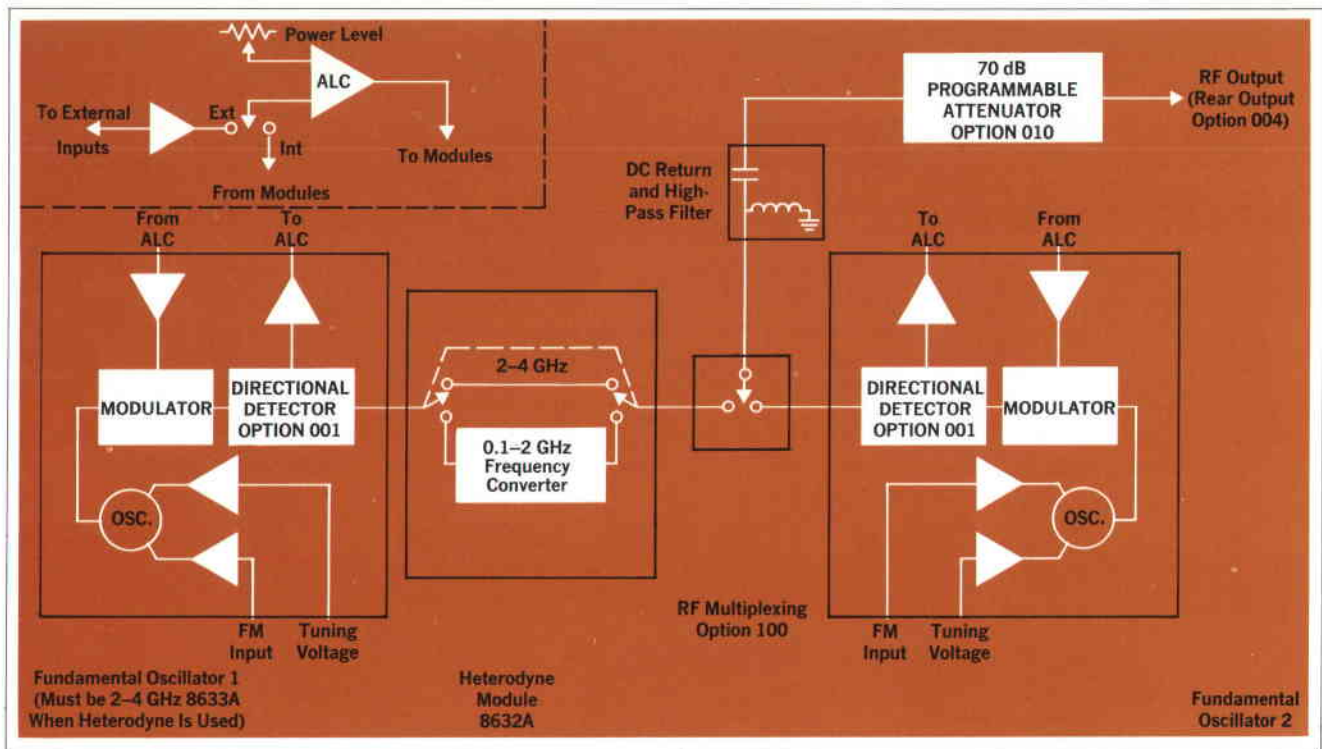

Fig. 3. Block diagram of rf drawer.

With the selector switch in the OFF position, a large capacitance is switched across the main YIG coil when in CW or slow sweep. This decreases the residual FM of the output signal. The FM input may still be used in this mode at high frequencies, as the response of the FM tickler coil is unaffected. However, low-frequency FM entering the main coil is severely limited.

The ALC amplifier located in the 8621A has four basic modes of operation: OFF, INTERNAL, EXTERNAL, and POWER METER. When used in the OFF position, a dc voltage is applied to the PIN modulator in the module being used. The Power Level control on the front panel is used to vary this voltage and therefore the attenuation of the modulator. This acts only as a variable attenuator; no rf leveling is achieved.

The internal mode of leveling uses the optional directional detector located in the module (the detector is standard in the 8632A heterodyne module). The internal detector is amplified by a preamplifier located in the module. To reduce temperature drift, a temperature-controlled IC operational amplifier is used. The IC amplifier chip contains a temperature-sensing network and heating circuit which keeps the amplifier chip at approximately 85°C regardless of the ambient temperature. With this highly stable dc amplifier, and with detectors compensated for temperature variations, as little as

0.1 dB change occurs in output power over a 50°C change in ambient temperature.

External leveling is also available so the rf may be leveled directly at the point of interest. The ALC loop is capable of handling both 10 and 20 dB couplers. A switch inside the drawer selects either positive or negative input detectors. The gain control for the loop is located on the front panel, so loop gain may be adjusted to a maximum, short of loop oscillation.

Power meter leveling using 10 or 20 dB directional couplers may also be used. The leveling may be done with HP Model 431B or C, or 432A Power Meters. Another switch inside the drawer selects the proper compensation for the power meter in use. An added bonus with power meter leveling is that the power meter doubles as a 5-dB step attenuator. Unfortunately the slow response of the thermistor does not allow fast sweep rates, so power meter leveling is not convenient when an oscilloscope trace is desired.

A lamp located on the front panel of the rf drawer indicates when power output of the instrument is adjusted too high to be leveled. In the 'ALC Off' position this lamp is lit to indicate that leveling is not being used.

One other rf component designed as an option is contained in the 8621A drawer: a wide band (dc-18 GHz) programmable attenuator. Thus in the most complicated

case the rf output of the oscillator proper must pass through the modulator, directional detector, rf switch, and attenuator. For the simplest case only the modulator is in the line. The microcircuitry contained in the rf modules is described in the second article in this issue.

General

The 8620A Sweep Oscillator was designed into a five inch high modular cabinet to contain a mainframe section and an rf section drawer. The circuit components are located on etched circuit boards which plug into a main mother board (Fig. 4). This method of interconnection eliminates a great deal of conventional wiring. For increased reliability the temperature rise of this instrument is kept at a minimum by the use of a fan which is mounted, at the rear of the mainframe, on a combination integrated cast motor mount and power transistor

heat sink. The air flow is directed into the mainframe and then out through the rear of the drawer, thereby cooling the oscillator modules also. A brushless dc motor is used to drive the fan blade. Thus the fan can operate from a power line of 50 to 400 Hz.

Front Panel Controls

All controls are functionally grouped in contrasting shaded areas. A front panel readout indicates the frequencies of five different functions (CW, start sweep, stop sweep, ΔF sweep, and CW vernier). A new pointer drive mechanism minimizes backlash and does not stretch with age, two problems common to older string-type drives. In this system, sprockets on the 5 control knob shafts drive the 5 pointers by means of perforated fiberglass belts. Band switching is accomplished by press-

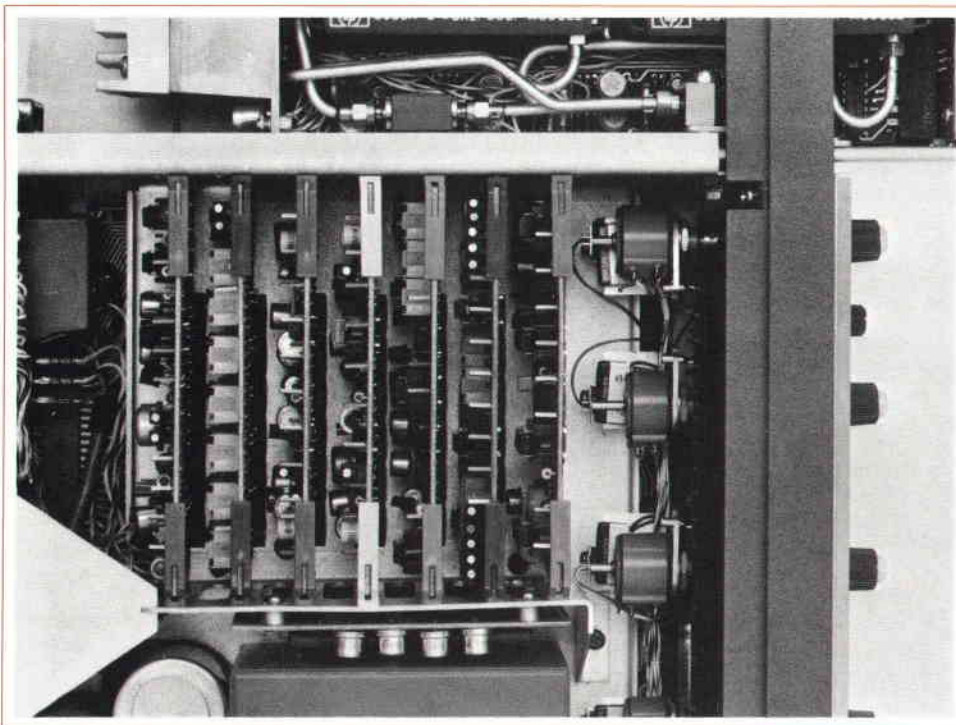

Fig. 4. Etched circuit boards all plug into a main mother board, reducing interconnecting wiring and enhancing serviceability.

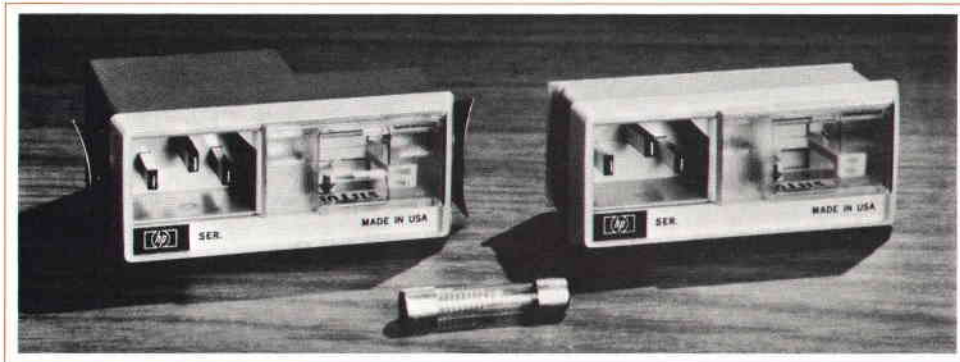

Fig. 5. New ac power line module protects user and instrument. Line cord must be disconnected before switch position or fuse can be changed. Arrangement meets international requirements.

ing a bi-directional cam lever which rotates the frequency drum in the direction the lever is pressed. This brings a new scale into view and simultaneously performs band switching in the rf drawer. The frequency scales for the drum snap into place, matching the frequencies of the plug-in rf modules, making scale changes easy when changing rf modules. Lighted pushbuttons are integrated into the centers of appropriate frequency control knobs to select and indicate operating modes. The mode graphics are color-coded to match the related frequency dial pointer. Printed-circuit slide switches are used for all detented switching, thereby unifying switching characteristics, increasing legibility, and simplifying control recognition.

Power Line Module

The 8620A is one of the first instruments to use the new HP ac power line module (Fig. 5). This unit replaces the line input connector, fuse, 115/230 volt switch, and rfi filter, in less space than the separate components occupy. The unit is shockproof when changing fuses, as the line cord must be disconnected before it is possible to change switch position or fuse. Also the 115/230V switch cannot be moved without first removing the fuse, reminding the user to select the appropriate fuse for the line voltage in use.

The unit is approved by the Underwriters' Laboratory, and recently won an Award of Excellence in the 1970 WESCON Industrial Design contest.

Service Philosophy

All major elements of the instrument were designed around the modular plug-in concept, including the front panel assembly. It is easily removed to service the dial as assembly and control components. All modules and boards are functionally independent to make it easy to isolate trouble to the individual defective module, and to restore service by exchanging modules. Modular exchange speeds restoration of service, and reduces repair costs.

Programmability

The 8620A Mainframe provides for remote programming of function, band, frequency, and attenuation. The functions and band program features are part of the standard mainframe, while frequency programming capability is a mainframe option and attenuation programming capability is an rf drawer option. Band, frequency and attenuation changes can be enabled with either contact closures or TTL outputs. Remote function selection

was designed for contact closure operation only; however, many TTL interface schemes will work as well. Frequency programming is a CW operation—12 remote lines can select up to 1000 discrete frequencies across the band. Remote attenuation programming is accomplished with 3 remote lines; rf attenuation is in 10 dB steps with a maximum of 70 dB.

Summary

Now that the 8620A Sweeper System is completed, it may be interesting to review the original objectives to determine how closely they were met. The 8620 System is indeed a small, easily transported solid-state microwave sweeper. It is easy to operate, it does have multi-band coverage; however, there are some areas which require continued effort. First, oscillators above 4 GHz have to be developed. There is an effort going on at the present time to push the operating frequency of transistor oscillators as high as possible. The second effort is the development of bulk effect oscillators. First, X band, then to be followed by P band (12.4 to 18.0 GHz) and finally C band. Concurrently with these oscillator programs, design effort will be going on to develop modulators and directional detectors to work in these same frequency ranges. Naturally, all of these oscillators and rf components must fit the same physical format as the present 2-4 GHz oscillator module. Also under development are power amplifiers (to be available as options) to boost the power output of solid-state oscillators to vacuum tube level. These amplifiers will also offset the loss encountered by the signal in passing through the modulators, directional detectors, rf switches, and attenuator. ■

Acknowledgments

As is usually the case with large projects such as that for the 8620A, many people, too numerous to mention all individually, contributed to the successful completion of the project.

Jim Fleming designed the 8621A RF Drawer and Bob Jacobsen designed the tuning dial and bandswitching assembly and the power line module.

The design team would like to express their appreciation to: Doug Gray who was project supervisor during the initial design stage, Poul Pedersen, who did the initial design of the mainframe circuits, Cyril Yansouni, who did the initial 8633A 2-4 GHz Module circuit design, and Jim Arnold, Helen Harris, and Charlie Vega of the production team, who worked with the design team to assure a smooth introduction of the instrument.

PARTIAL SPECIFICATIONS
HP Model 8620A
Sweep Oscillator
 (With rf Units and Drawer Installed)

FREQUENCY:
FREQUENCY RANGE: Determined by band switching lever and rf oscillator modules installed in 8621A drawer.
SWEEP FUNCTIONS:
START/STOP SWEEP: Sweeps from START to STOP frequency setting.
END-POINT ACCURACY: Same as frequency accuracy.
ΔF SWEEP: Sweeps upward in frequency, centered on CW setting.
WIDTH: Continuously adjustable from zero to 1% or zero to 10% of usable frequency span. Scale calibrated directly in MHz.
WIDTH ACCURACY: ±1% of maximum ΔF plus ±3% of ΔF swept.
FREQUENCY MARKER: Amplitude or intensity marker.
ACCURACY: Same as Frequency Accuracy.
RESOLUTION: Better than 0.25% of rf unit bandwidth.
CW OPERATION: Single frequency output control, CW/Marker.
CW VERNIER: Calibrated direct to MHz about CW setting, ±0.5% or ±5% of full bandwidth selectable, front-panel switch.
ACCURACY: Same as frequency accuracy.
PRESET FREQUENCIES: Start/stop sweep end points and CW frequency can be used as three preset CW frequencies.
SWEEP MODES:
AUTO: Sweep occurs automatically.
MANUAL: Continuously adjustable between and frequencies as set.
TRIGGERED: Actuated by front-panel switch, or external signal.
SWEEP OUTPUT: Sawtooth, zero to approximately +10V.
MODULATION:
INTERNAL AM: Square-wave modulation, adjustable from 950-1050 Hz.
EXTERNAL AM FREQUENCY RESPONSE: Dc to 100 kHz unlevelled, dc to 50 kHz levelled at rated output.
EXTERNAL FM & PHASE-LOCK: Refer to rf unit specifications.
GENERAL:
BLANKING: rf automatically attenuated during retrace.
RETRACE: Manual, continuously adjustable between and frequencies as set.
REMOTE BAND SELECT: Available at programming connector.
FURNISHED: Power cable, rack-mounting kit, accessory kit.
DIMENSIONS: 5 1/2 in (133.4 mm) high, 11 in (279.4 mm) deep, 16 1/2 in (425.5 mm) wide.
PRICE: Model 8620A \$1450.00.
Option 001
Remote Frequency Programming
FUNCTION:
FREQUENCY: 1000 points, 12-line BCD plus one line enable.
PRICE: Option 001, \$500.00.

PARTIAL SPECIFICATIONS
HP Model 8621A
RF Drawer

FREQUENCY RANGE: Up to 18 GHz.
OSCILLATOR CAPACITY: One fundamental oscillator or one fundamental oscillator and heterodyne converter. Multiplexing for above, standard.
LEVELING INDICATOR: Front-panel indicator lights when unlevelled.
EQUIVALENT SOURCE MATCH:
EXTERNALLY LEVELED: Depends on coupler.
UNLEVELED: Less than 2.0:1.
INTERNALLY LEVELED: Less than 1.8:1.
POWER LEVELING AMPLIFIER:
CRYSTAL INPUT: Used with positive or negative polarity detector.
POWER METER INPUT: Compensation for HP Models 431B, 431C, 432A.
PRICE: Model 8621A, \$300.00.
Option 100
OSCILLATOR CAPACITY: Two fundamental oscillators and one heterodyne converter. Multiplexing for above, standard with option.
ALL OTHER SPECIFICATIONS: Same as 8621A above.
PRICE: Option 100, add \$400.00.
Option 010, 70 dB Attenuator
ATTENUATION RANGE: 70 dB in 10 dB steps.
ATTENUATION ACCURACY (including frequency response):
 Up to 12.4 GHz: Less than ±3% of attenuation used.
 12.4 to 18 GHz: Less than ±5% of attenuation used.
PRICE: Option 010, add \$850.00.
Option 004, Rear rf Output
PRICE: Option 004, add \$75.00.

Insertion Losses
For 8621A RF Drawer
and Options*

Options Included in 8621A RF Drawer	Insertion Loss Due to Optional RF Drawer Components
Multiband Configuration	Up to 12.4 GHz
Option 100	12.4 to 18 GHz
Yes	0.8 dB
No	1.0 dB
Yes	1.8 dB
No	2.1 dB

*Option 004, Rear Output. No Insertion Loss.

PRICE: Model 8620A \$1450.00.

PARTIAL SPECIFICATIONS
HP Model 8630A Series
RF Oscillator Modules

Specifications in 8620A/8621A System	RF Oscillator Modules			
	8632A	8633A	3634A	3635A
FREQUENCY	0.1-2 GHz	1.8-4.2 GHz	4-8 GHz	6-12.4 GHz
FREQUENCY RANGE	±20 MHz	±20 MHz		±20 MHz
FREQUENCY ACCURACY (25°C), CW Mode	±1 MHz	±1 MHz		±1 MHz
FREQUENCY STABILITY	< 20 kHz peak	< 15 kHz peak		< 15 kHz peak
With 10 dB power level change				
Residual FM, CW Mode				
LINEARITY: As % of sweep width.				
POWER OUTPUT				
MAXIMUM LEVELED POWER:	> +10 dBm (10 mW)	> +10.0 dBm (10 mW)		
POWER VARIATION:			To Be Announced	To Be Announced
INTERNALLY LEVELED	±0.7 dB	±0.6 dB		
EXTERNALLY LEVELED	±0.1 dB	±0.1 dB		
SPURIOUS SIGNALS (down from fundamental):				
HARMONIC IN dB	> -30 dB	> -20 dB		
NONHARMONIC IN dB	> -30 dB	> -50 dB		
RESIDUAL AM: 100 kHz bandwidth	> -50 dB	> -50 dB		
MODULATION				
EXTERNAL FM (8621A Rear Panel):				
FREQUENCY RESPONSE	Dc to 2 MHz	Dc to 2 MHz		
MAXIMUM DEVIATION: Dc-100 Hz rates	±2 MHz	±2 MHz		
TO 2 MHz rates	\$1750.00	\$1850.00		
PRICE—Basic Model:	No Charge	\$250.00		
INTERNAL LEVELING Add				

Carl J. Enlow



Carl Enlow received his BSEE degree from the University of Illinois in 1967. Soon thereafter, he joined HP and the 8620 Sweep Oscillator design team. Ultimately, Carl took responsibility for the electrical design of the 8620 mainframe.

Previous to joining HP, Carl served three years in the Navy and worked for the Magnavox Company in Champagne, Illinois supervising production of electronic organs and evaluating and

designing specialized test equipment. Carl's hobbies are golf and tennis.

Phillip G. Foster



Phil Foster counts among his accomplishments contributions to the product design of the HP 140A Oscilloscope, the 191A TV Waveform Monitor, the 8690, 8601 Sweep Oscillators and his recent direction of design of the 8620 series sweepers.

After receiving his AA in Mechanical Engineering from San Francisco City College, Phil spent four years in the Air Force maintaining microwave communication equipment. Phil's outside interests include

backpacking, fishing, hunting and sailing his Melody sailboat. Phil's product design team for the 8620 Sweep Oscillator included Bob Jacobson and Jim Fleming.

Robert H. Bathiany



Bob Bathiany received his BSEE and MSEE degree from the University of Washington in 1967 and 1969. Upon joining Hewlett-Packard, Bob assumed responsibility for the ALC, YIG driver and FM circuits in the 8620A Sweep Oscillator.

While in school, Bob designed electronic/chemical laboratory control instrumentation for Weyerhaeuser Corporation. Bob is a member of IEEE's Semiconductor Circuit Design Group. He enjoys model boating, camping and fishing in his spare time.

Stephen Vitkovits



The 8620 section manager, Steve Vitkovits, began his career at HP in 1963 with the Rockaway, N.J. Division developing a sweep generator, the 4800 and 4815 Impedance Meters and the 3205A FM Signal Generator. Previous to joining HP, Steve was responsible for development of frequency synthesizers at both Westrex and Aircraft Radio Corporation. Steve received his BSEE and MSEE (in 1957 and 1964) from the Newark College of Engineering. Steve is

a member of IEEE, Tau Beta Pi and Eta Kappa Nu and holds one patent. As a member of the Golden Gate Live Steamers, Steve is an enthusiastic builder of live model steam railroad and boat engines.

Microcircuits for the Microwave Sweeper

By Ronald E. Pratt, Robert W. Austin and
Arlen Dethlefsen

VIRTUALLY ALL THE RF CIRCUITRY in the HP Model 8620A Microwave Sweep Generator is hybrid thin-film microcircuitry developed and fabricated in house. The frequencies from 0.1 to 4.2 GHz are produced by two rf modules which plug into the sweeper's rf drawer. One of these modules (Model 8633A) has a YIG-tuned transistor oscillator that is swept from 1.8 to 4.2 GHz. The second module (Model 8632A) heterodynes with the first to produce a swept output from 0.1 to 2.0 GHz. Fig. 1 is a block diagram of the microcircuits used to generate the 0.1 to 4.2 GHz swept signal.

Microcircuits for the 8632A Heterodyne Module

The design objective for the 8632A Heterodyne Module was to provide a 0.1-to-2.0 GHz signal with a power level in excess of +10 dBm, with spurious and harmonic signals more than 30 dB down from the fundamental, internal leveling, and a minimum of space and complexity. These were the techniques used to accomplish this:

- Heterodyning a 2.3 to 4.2 GHz YIG oscillator with a 4.3 GHz local oscillator allowed coverage of the 0.1 to 2.0 GHz band in one continuous sweep.
- The YIG oscillator signal was used as the low level signal. This eliminated the need for switching the position of the modulator or the use of two modulators for the two frequency bands.
- Troublesome spurious signals and local oscillator leakage were minimized by using a local oscillator frequency of 4.3 GHz. This choice of LO frequency also allows the swept signal to be used below 100 MHz since the two mixing signals (4.2 and 4.3 GHz) are easily filtered out.

- A PIN transfer switch eliminated the need for a bulky, possibly expensive mechanical switch, its associated rf cabling and limited life.
- A resistive bridge type directional detector accomplished internal leveling with a minimum of space and cost.
- A high-gain wideband amplifier minimized the spurious signal levels and provides the required output power.

The 8632A Heterodyne Module contains two microcircuit packages, a frequency converter package and a 0.1–2 GHz amplifier package.

0.1–2.0 GHz Frequency Converter

The frequency converter contains five separate microcircuit substrates:

- 1) Directional Detector/Switch
- 2) Filter/Coupler
- 3) 4.3 GHz Oscillator
- 4) Mixer
- 5) 2 GHz Low Pass Filter

Thin film microcircuit techniques have made it possible to house these circuits in a 2 x 2 x 1/2 inch package.

Directional Detector/Switch

Fig. 2 is a simplified schematic of the circuitry of the Directional Detector/Switch substrate and Fig. 3 shows the circuit layout. The circuitry is contained on a 1 x 0.25 x 0.025 inch sapphire substrate. The directional detector portion of the circuitry is contained on the left side of the figure and the transfer switch circuitry is contained on the right.

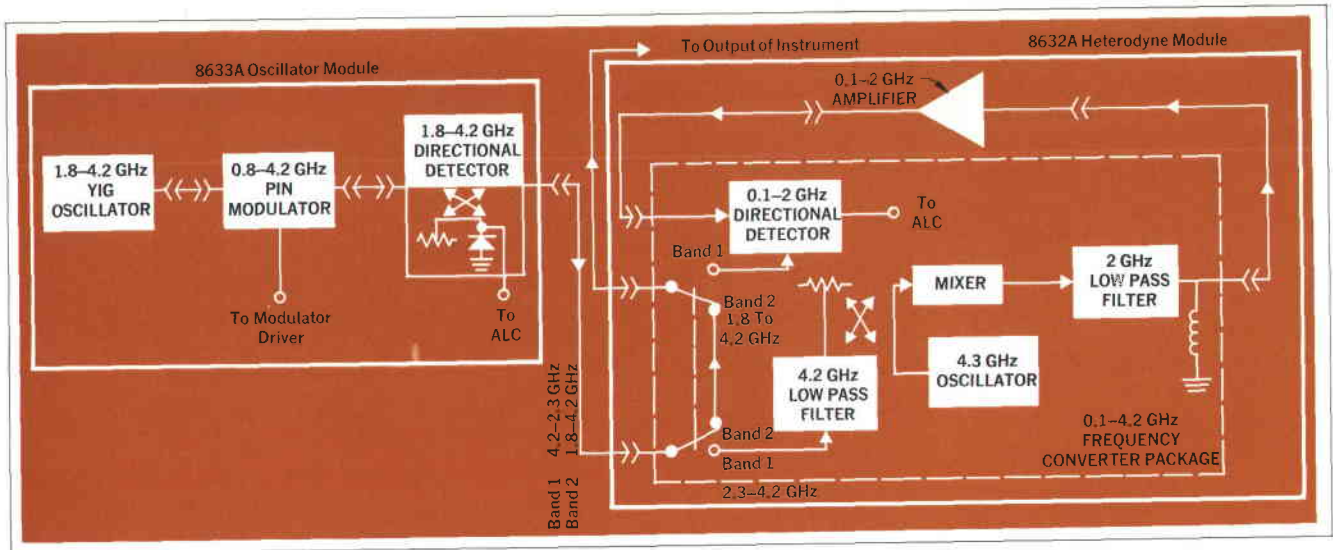

Fig. 1. Block diagram of microcircuits used in 8620A Sweep Signal Generator to produce signals from 0.1 to 4.2 GHz.

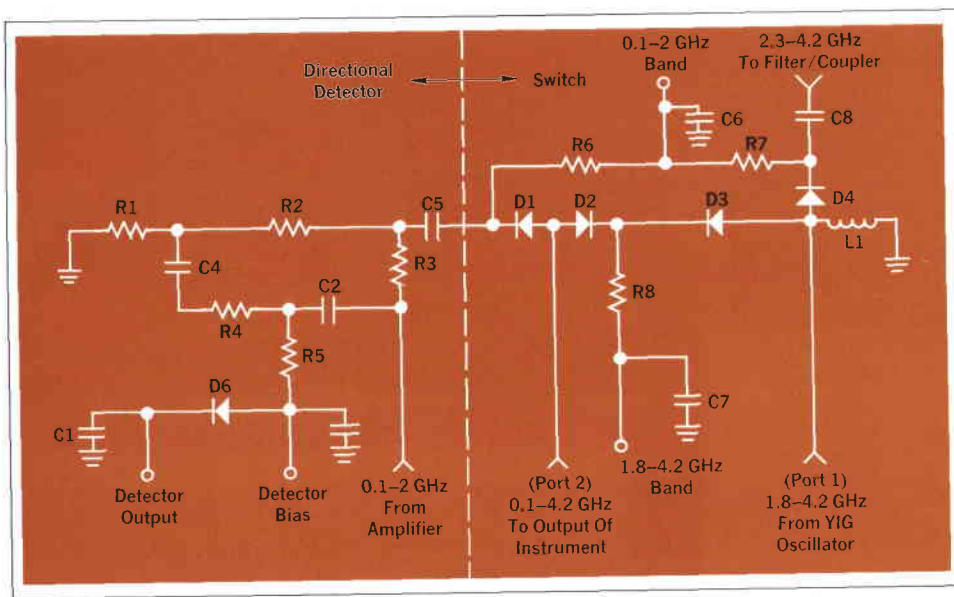

Fig. 2. Schematic diagram of directional detector/switch microcircuit.

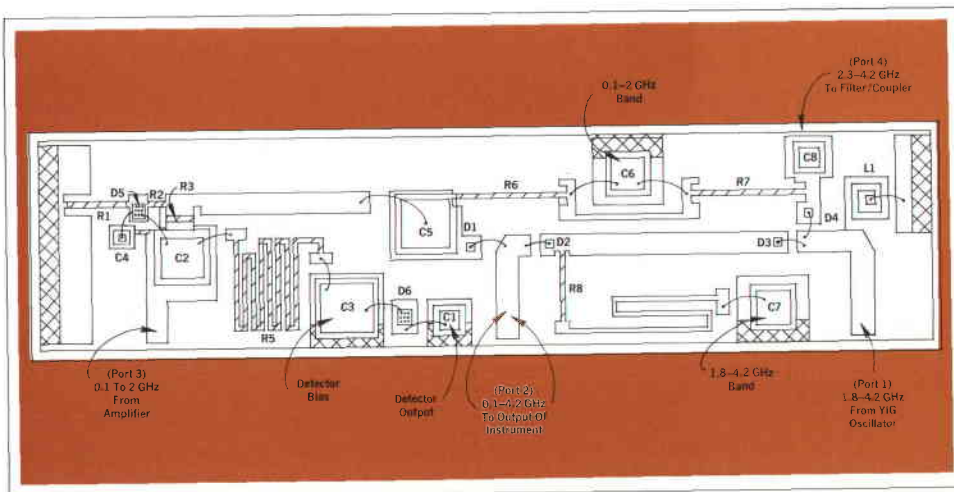

Fig. 3. Directional detector/switch microcircuit layout.

Switching is accomplished by diodes D1 through D4. When the 1.8 to 4.2 GHz band is desired, -10 volts is applied to resistor R8. This forward biases diodes D2 and D3 allowing the rf signal to flow from the YIG oscillator to the output of the instrument. When the 0.1 to 2.0 GHz band is selected, diodes D1 and D4 are forward biased through resistors R6 and R7, allowing the YIG oscillator signal to be mixed with the 4.3 GHz local oscillator. The output of the 0.1 to 2.0 GHz amplifier passes through diode D1 to the output of the instrument. Inductor L1 provides a dc return for diodes D3 and D4. The dc return for diodes D1 and D2 is external to the frequency converter package.

During 0.1 to 2.0 GHz operation, isolation between the YIG oscillator and the output of the instrument is an important parameter to minimize leakage of the oscillator to the output of the instrument. Isolation typically greater than 40 dB is accomplished by using 60-mil-square PIN diodes with C_0 less than .05 pF. Fig. 4 shows the insertion loss, VSWR and isolation characteristics between port 1 and 2 of the switch.

The directional detector is diagrammed in Fig. 5.

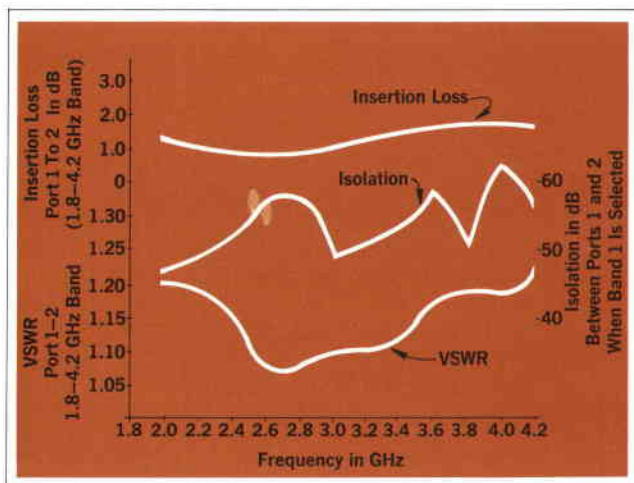

Fig. 4. Curves describe insertion loss, VSWR, and isolation between ports 1 and 2 of directional detector/switch.

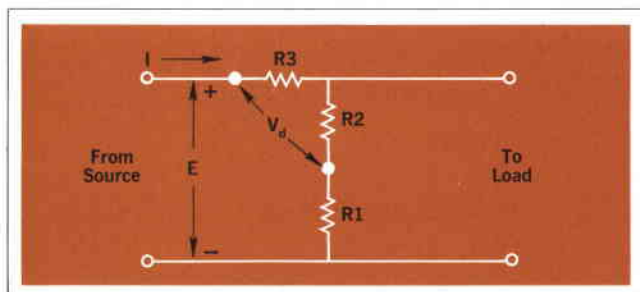

Fig. 5. Basic directional detector circuit.

Resistors R1, R2 and R3 form the resistive bridge. Hot carrier diode D5 is used as the detecting diode. Capacitor C4 and resistor R4 are frequency compensating components for hot carrier diode D5, to obtain flat response from 0.1 to 2.0 GHz. Resistor R5 is large to minimize unbalancing of the resistive bridge while allowing diode D5 to be forward biased. The biasing increases the sensitivity of the diode. Diode D6 is identical to diode D5 to temperature-compensate the detected output voltage. Fig. 6 shows a typical plot of the detected output voltage response and directivity as a function of frequency.

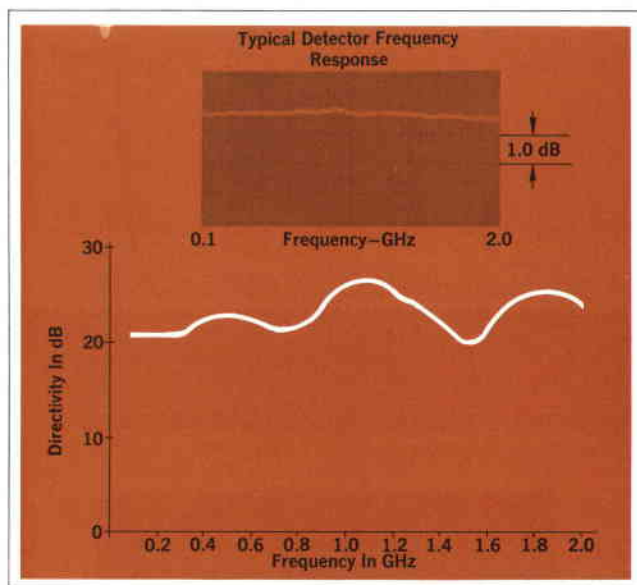

Fig. 6. Detector output and directivity as functions of frequency.

Filter/Coupler

The second harmonic of the YIG oscillator can be only 20 dB down from the fundamental. If this harmonic were allowed to reach the mixing diode, spurious output signals would be only 20 dB down from the desired signal. The Filter/Coupler substrate attenuates the second harmonic of the YIG oscillator and combines the low level signal and the 4.3 GHz local oscillator signal for application to the mixing diode.

The 4.2 GHz low-pass filter is a 15-section Chebyshev design. To minimize the inductor capacitance, the ground plane was etched away beneath the inductors.

The coupler provides 10 dB of coupling and approximately 10 dB of directivity. The directivity of the coupler minimizes the interaction of the low level signal with the 4.3 GHz oscillator. Fig. 7 shows the filter/coupler layout and Fig. 8(a) and 8(b) show typical electrical characteristics of the filter coupler.

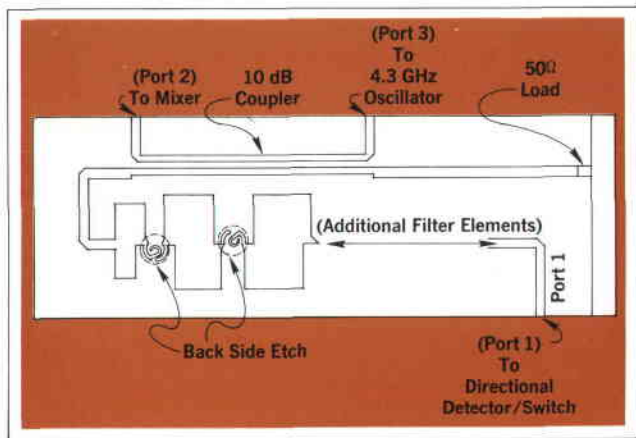

Fig. 7. Layout of filter/coupler microcircuit.

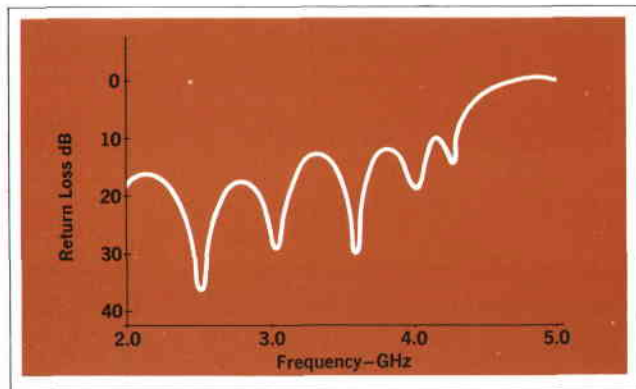
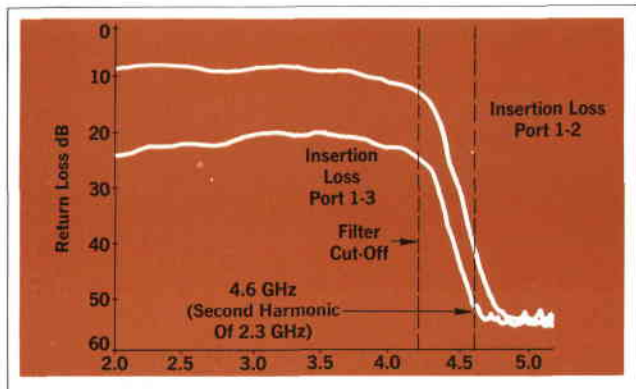

Fig. 8. a) Insertion loss between port 1-2 and 1-3 of filter/coupler. b) Return loss of port 1 of filter/coupler.

4.3 GHz Oscillator

The 4.3 GHz oscillator is a push-pull design. This allows the transistors to be operated in the common base configuration; it minimizes the second harmonic output and delivers more rf output power than a single transistor oscillator would provide, using the same type of transistor. A simplified schematic is shown in Fig. 9.

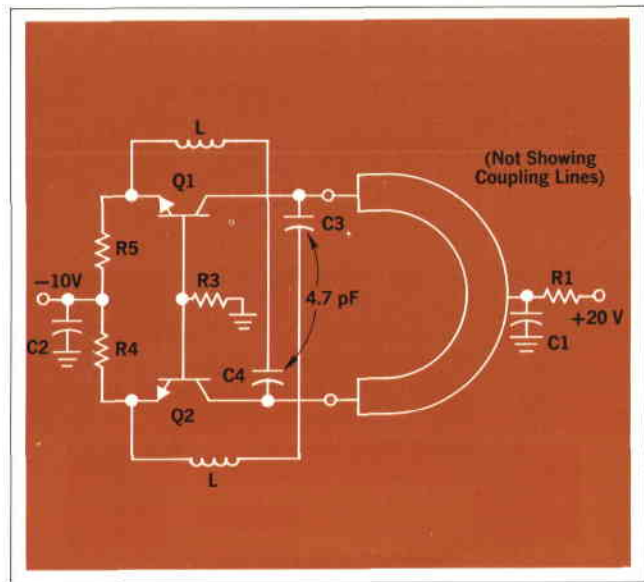

Fig. 9. Simplified schematic diagram of 4.3 GHz oscillator.

Analysis is easier if the circuit is transformed into an equivalent unbalanced rf circuit, as in Fig. 10. The push-pull action is replaced here by an ideal transformer which performs the 180° phase shift.

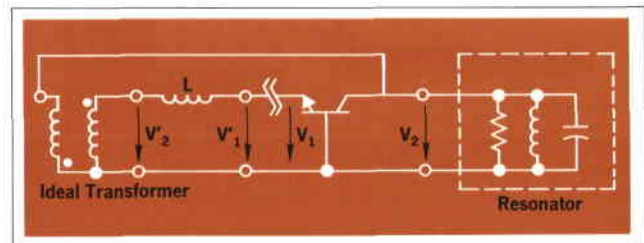

Fig. 10. Equivalent circuit of 4.3 GHz oscillator.

The vector diagrams shown in Fig. 11(a) through 11(d) graphically explain why the circuit is able to oscillate. For this purpose the emitter path is broken and a signal V_1 is applied to the emitter. If we make the simplifying assumption that the resonator represents 50 ohms at the resonant frequency, V_2 can be approximated by

$$V_2 = V_1 \times \frac{S_{21}}{1 + S_{11}}$$

where S_{11} and $S_{21} = S$ parameters of the transistor at 4.3 GHz. Push-pull performance transforms V_2 to V'_2 . V'_2 sees an inductance L in series with the input impedance of the transistor (represented by a parallel combination of R and L equivalent to S_{11}). This network induces a V'_1 at the starting point of the loop which is in phase with the originating signal V_1 yet is greater than V_1 . Therefore oscillation is assured.

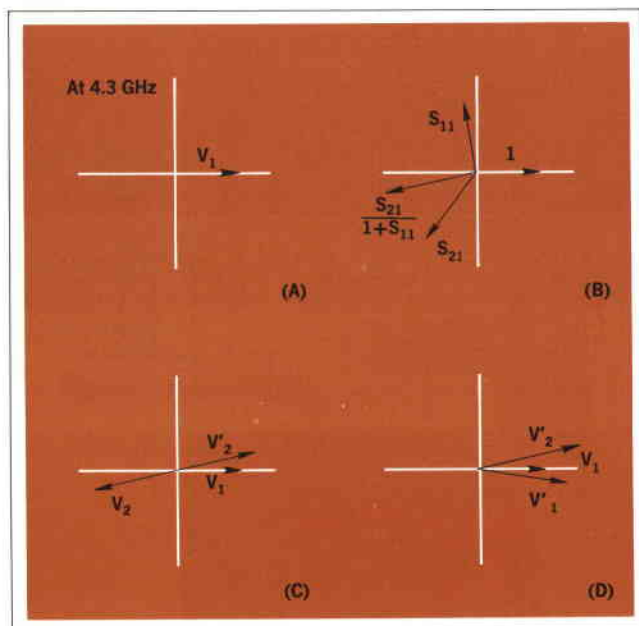

Fig. 11. Vector diagrams describe behavior of 4.3 GHz oscillator.

The 4.3 GHz oscillator layout shown in Fig. 12 is built on a 1/2-inch-square 25-mil sapphire substrate. The two transistor chips are actually mounted on a coupling loop which decouples them from the U-shaped microstrip resonator. The two one-mil wires which connect the ends of the resonator to opposite emitters represent the feedback inductors. The emitter dc potential is blocked from the resonator by two 4.7-pF SiO₂ chip capacitors. To prevent other unbalanced oscillation modes, the common base pad of the two transistors is

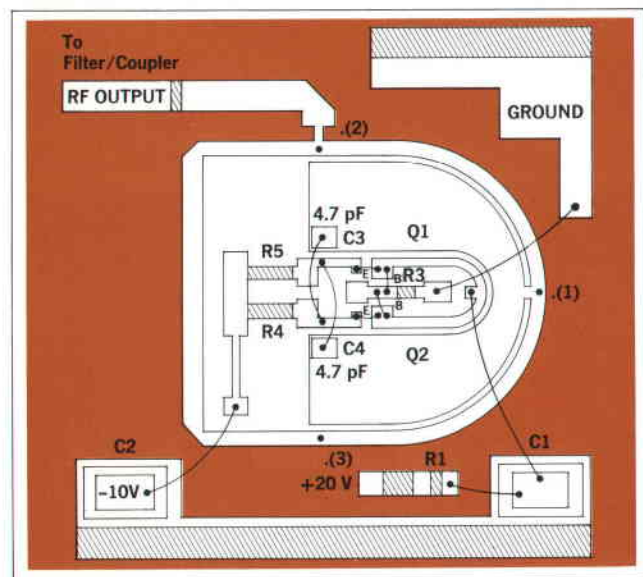

Fig. 12. Layout of 4.3 GHz push-pull microcircuit oscillator.

connected to dc ground via resistor R3. Thus it acts only as ground when the devices are working push-pull.

The resonator is surrounded by a microstrip-line which couples out the rf. Point 1 is the floating ground of the resonator with zero rf voltage and maximum rf current. Maximum power is obtained if the short path from 1 to 2 is $\lambda/4 \times (2k + 1)$ and the long path from 1 to 2 via 3 is $\lambda/4 \times (2k + 3)$ ($k = 1, 2, 3, \dots$, $\lambda =$ wavelength on sapphire). This unbalances the symmetrical signals and adds them at point 2.

The output power obtained is typically +10 to +13 dBm. Frequency drifts at a rate of -500 kHz/ $^{\circ}$ C. This is caused mainly by the high temperature drift in the dielectric constant of the sapphire. Harmonics are typically more than 40 dB below the fundamental.

Fine tuning of the oscillator is accomplished by varying the collector voltage. Changing collector voltage varies the collector-to-base capacitance which in turn affects the frequency of oscillation. The -500 kHz/ $^{\circ}$ C frequency shift of the oscillator is compensated by providing a collector voltage supply which increases linearly with increasing temperature.

Mixer

It was possible to meet the spurious objective (30 dB down from the fundamental) with a single hot carrier diode. This eliminated the need for a more complex and expensive balanced mixer configuration. The mixer diode is placed on a separate $0.5 \times 0.125 \times 0.025$ inch high alumina substrate. Since no resistors were required on this substrate, high alumina material could be used in place of sapphire. This reduced the cost of the mixer. Placing the mixer diode on a separate substrate also allows for easy replacement in case of diode failure.

Fig. 13 shows the layout of the mixer. Tuning stub (1) grounds one side of the diode while acting as a tuning element for the mixer.

2 GHz Low Pass Filter

The 2 GHz low pass filter attenuates the higher order mixing products and the low level and local oscillator signals. The filter, constructed on a 50 mil sapphire substrate, is of elliptical design to achieve extremely sharp cut-off characteristics since the filter must pass 2.0 GHz, yet highly attenuate higher frequency signals starting at 2.3 GHz. Fig. 14 shows the filter layout and Fig. 15 shows typical filter cut-off characteristics.

The YIG-tuned transistor oscillator¹ for the 8633A Oscillator Module and the wideband amplifier² for the 8633A Heterodyne Module have been described elsewhere.

Microcircuits for the 1.8-to-4.2 GHz Oscillator Module

The PIN Modulator

A new PIN diode modulator provides rf blanking, amplitude modulation, and automatic level control. Thin-film microcircuit construction and the use of unpackaged diodes having small parasitic reactances made it possible to produce a lumped circuit attenuator design which works from 0.8 to 4.2 GHz. PIN diodes are used as current-controlled microwave resistors. The new circuit has a 60 dB dynamic range with a VSWR of less than 2:1 at any attenuation, and is built on a sapphire chip 0.230" wide by 0.460" long; it is many times smaller than conventional distributed-circuit modulators.

Fig. 16 shows that the circuit is a bisected Pi attenuator formed by diodes D1, D2, D6, and D7 which provide 40 dB of attenuation. D3, D4 and D5 provide attenuation from 40 to 60 dB. For small attenuation, D2 and D6 are forward biased by driving a negative current into the control lead. For maximum attenuation, a positive control current is applied, thus biasing D3, D4, and D5. Any reflected signal from the shunt diodes is attenuated twice by D2 and D6 which are essentially at zero bias due to D1 and D7 drawing current from the plus supply. At this point D1 and D7 are biased to have a 25 ohm rf resistance which together with the 25 ohm fixed resistors give a 50 ohm input and output impedance. For the first 40 dB of attenuation, the rf resistances of D1, D2, D6, and D7 closely follow the optimum values for a Pi attenuator thus producing a well matched device. The smaller RC networks in shunt with D2 and D6 minimize the effects of diode junction capacitance.

Before the first breadboard version of this modulator was built, various circuit elements were characterized separately, and an equivalent circuit was analyzed on a time-shared computer. This analysis made it possible to

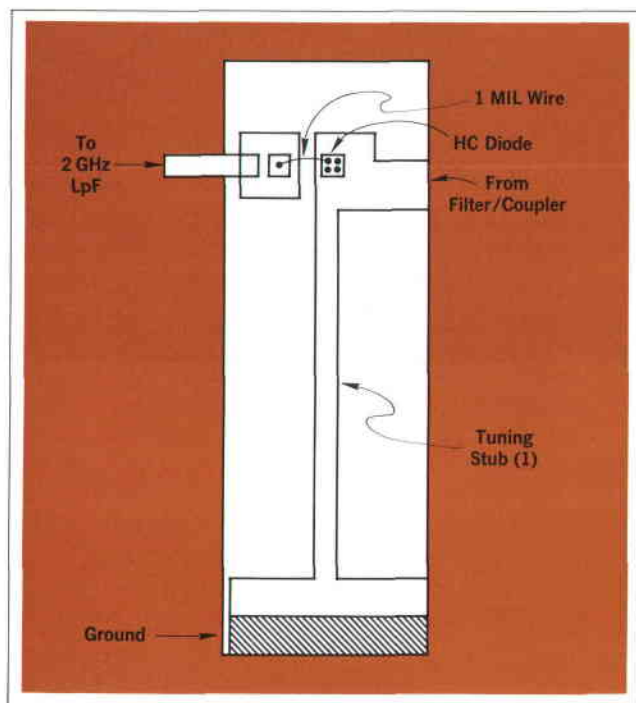

Fig. 13. Layout of mixer microcircuit.

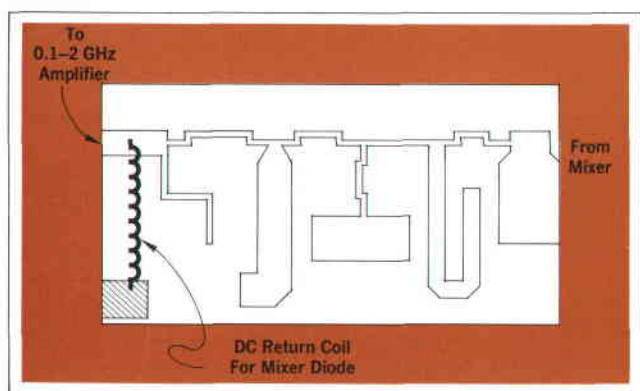

Fig. 14. Layout of 2-GHz low pass filter microcircuit.

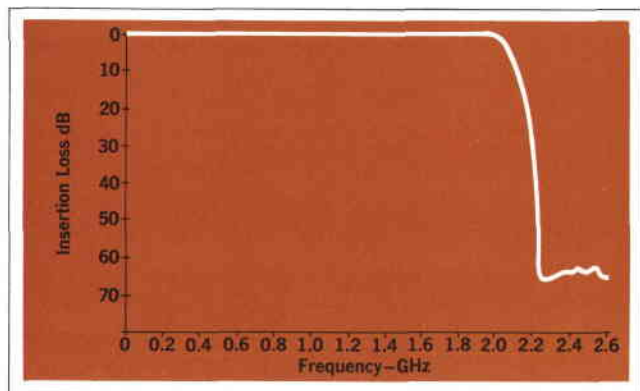

Fig. 15. Frequency response of typical 2-GHz low-pass filter.

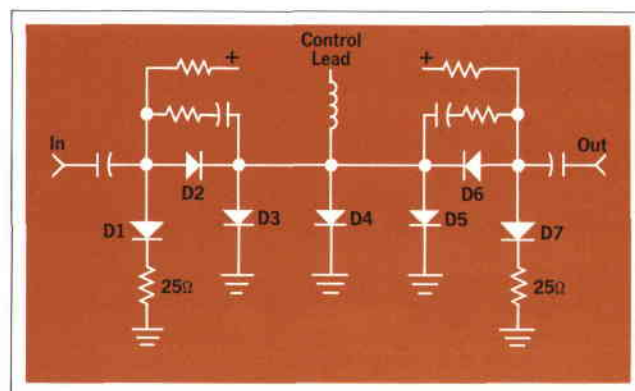

Fig. 16. Equivalent circuit of PIN diode modulator-attenuator.

adjust circuit parameters to achieve the final performance. The decision to use three shunt diodes was made when the equivalent circuit would not produce sufficient attenuation with fewer diodes. The effect of the RC networks was also predicted by the computer model. A special non-linear analysis program was used for optimizing the values of the positive dc supply and the bias resistors, to provide the best possible transfer function and impedance match. Fig. 17 shows some of the equivalent circuit elements used for the computer analysis. It is interesting to note that even a simple thin-film resistor must be analyzed as a transmission line to perform accurately in the circuit model. The values shown were either directly measured or verified experimentally.

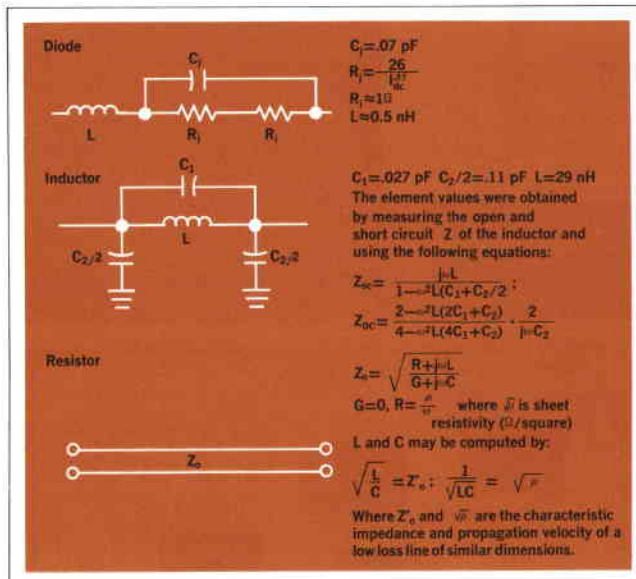

Fig. 17. Equivalent circuit elements of PIN modulator-attenuator.

The use of series and shunt diodes shows a unique advantage when the overall ALC loop is considered. If the transfer gain of any modulator is defined as the change in control current necessary to provide a certain change in rf power, it can be shown that the gain of most shunt-diode modulators varies approximately directly with the amount of attenuation introduced. For example, the current change necessary to vary the rf power from -20 to -22 dB will be about 10 times larger than it was going from -10 to -12 dB. Reducing loop gain would degrade ALC performance as the leveled power output is reduced by changing the rf output control, thus causing more power variations and poorer source match. The series shunt modulator avoids this problem by obtaining most of its dynamic range with very low bias currents. Typically there is about 10 dB change over the first 30 dB

of dynamic range, thus providing effective leveling over the entire range of the power level adjustment.

1.8-4.2 GHz Directional Detector

The basic function of a directional detector is to sense rf energy from one direction without regard to other signals, and produce a dc voltage proportional to the rf amplitude. The device can be broken into two sections for analysis: a directional coupler plus a crystal detector. For wideband applications, these two units may be developed separately, then combined to give the desired performance. For this microcircuit unit it was necessary to compensate the directional coupler to achieve the desired output from the combined coupler/detector unit.

The 'directional' qualities of the device are completely a function of the coupler directivity. As can be seen in Fig. 18, it is desired to sense a signal at port 3 for a wave incident at port 1, but to receive no signal at port 4. Conversely, a signal incident on port 2 would not transmit energy to port 3. In actual units, there is a very

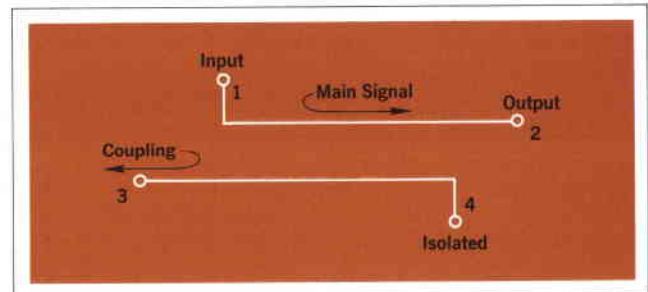

Fig. 18. Directional coupler.

small error signal at the 'isolated' port, and it is convenient to define the coupler directivity as $10 \log \frac{P_1}{P_3}$ for the same conditions. It is evident, then, that the directional coupler can be used to sense a forward wave while ignoring (or almost so) the reverse wave (the wave incident on port 2 as the result of a reflective load, etc.).

The second section of a directional detector is the crystal detector unit (diode detector). This unit senses rf energy and converts it to a filtered dc signal. A second tracking diode is added for temperature compensation of the unit. The diodes are Schottky barrier types and require a dc bias to lower the junction resistance for rf to dc conversion. Fig. 19 shows a schematic.

When the two sections are combined, it is necessary to adjust coupling characteristics to first compensate for an inherent rise in dc output with increasing frequency of the detector circuit, and secondly to compensate for cable losses before the output signal reaches the front panel. This gives the unit a -0.75 dB frequency response from 1.8-4.2 GHz with a minimum directivity of 26 dB. The

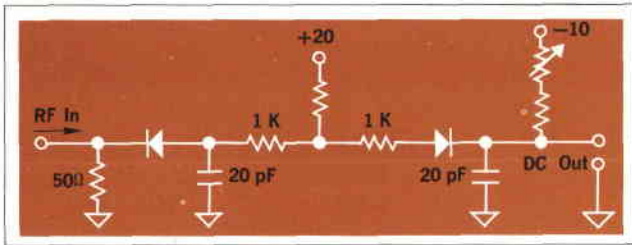

Fig. 19. Temperature-compensated crystal detector.

coupling has a maximum ripple of $\pm .25$ dB.

Inside the directional detector one finds some new ideas for thin film integrated circuits. Because a directional coupler is a precision device, simple microstrip geometrics will not meet all the electrical requirements. First, ground currents that are interrupted tend to launch higher order modes inside the package, which leads to poor directivity. Secondly, mixed dielectric media had two large error signals due to mismatched mode impedances. Again the directivity is adversely affected. To solve these problems, a symmetrical structure called 'triplate' was incorporated in a unique sandwich-structured box (Fig. 20) using two dielectric substrates instead of the usual single unit.

It should also be mentioned that high alumina substrate material was used rather than synthetic sapphire

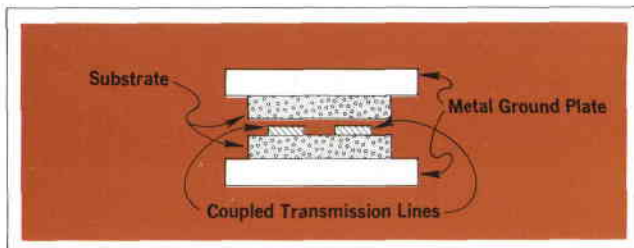

Fig. 20. 'Triplate' sandwich structure used in microcircuit directional detector.

because of the anisotropic properties of sapphire (the magnitude of the dielectric constant is a function of the direction of energy propagation in an anisotropic medium).

Acknowledgment

Much credit is due to Cyril Yansouni for design concepts for the 8632A Heterodyne Module. Dieter Scherer was responsible for the original design concepts for the 4.3 GHz local oscillator used in the frequency converter package. Special thanks go to Bob Jacobsen for the design of the frequency converter package.

Ronald E. Pratt



Ron Pratt received his BSEE in 1967 from the Newark College of Engineering the hard way—at night school while holding a full time job at Bell Telephone Labs. Ron was responsible for development of the PIN Modulator for the 8633A Heterodyne Oscillator. Night school still fills a large part of Ron's time with teaching of Microwave Electronics two nights a week at Foothill College. High fidelity and a gleaming Porsche for autocross racing help complete Ron's busy schedule. Ron belongs to the Microwave Theory and Techniques Group of IEEE.

Robert W. Austin



Soon after graduating in 1968 from Seattle University with a BSEE, Bob Austin joined Hewlett-Packard. He immediately joined the team designing the 8620 Sweep Oscillator and took sole responsibility for the directional coupler. Bob is now involved in packaging design and microcircuit processing at HP.

This fall, Bob began studies toward an MSEE at Stanford.

Racing his TR4 sportscar is Bob's idea of an exciting weekend. So far, he has only been in autocross races but he plans to road race next year. Bob is a member of IEEE's Microwave Theory and Techniques Group.

Arlen E. Dethlefsen



Arlen Dethlefsen joined HP in late 1968 after five years with Bell Telephone Labs where he helped develop microwave radio systems. Arlen received his BSEE and BS in mathematics from California Polytech in 1961 and an MSEE in 1963 from Northwestern University. As project supervisor, Arlen was responsible for microcircuit development for the 8632A Heterodyne Converter. Skiing takes up much of Arlen's time in the winter months while his summer pastime is playing tennis.

HP Archive

This vintage Hewlett-Packard document was
preserved and distributed by

www.hparchive.com

Please visit us on the web!

On-line curator: John Miles, KE5FX

jmiles@pop.net

