

HEWLETT-PACKARD JOURNAL



SEPTEMBER 1970

A Programmable, Modular, Bidirectional Data Coupler

Instrumentation coupler, automated test system controller, computer interface . . . This new coupler/controller assumes many identities to create a broad range of new possibilities for system automation.

By Gibson F. Anderson

IF COMPUTERS, INSTRUMENTS, AND PERIPHERALS COULD SPEAK, and if they all spoke the same language, there would be few interface problems. Computers could tell instruments what to do, and the instruments would respond with data. The computer would analyze the data and then order peripherals to produce reports. Since this isn't the way things are, interface problems have to be solved either by special hardware, which can be expensive, or by human beings, who have better things to do than take long lists of readings and laboriously key the data into a calculator or time-sharing terminal.

Model 2570A Coupler/Controller is designed to solve such problems by 1) translating the digital outputs of instruments, calculators, computers, and peripherals to a common code, and 2) providing a means for the exchange of information in this common code. Modular and programmable, the coupler/controller can serve as the nucleus of many different kinds of systems in diverse application areas, from engine testing to laboratory automation to automated instrument calibration.

What It Does

The coupler/controller allows up to eight digital devices of various kinds to communicate with each other. Such diverse character codes as binary-coded decimal from digital voltmeters and the six-bit coded output of the HP 9100A/B calculator are converted on plug-in printed-circuit cards to a common code, ASCII (American Standard Code for Information Interchange). As many as eight of these printed-circuit input/output cards plug into the coupler/controller mainframe (see Fig. 1), which is basically a card cage, a power supply, and control logic for the I/O cards.

In the backplane of the mainframe is an ASCII bus. The I/O cards all connect to this bus, and information is transferred via the bus. Information is transmitted serially, character by character, in ASCII. Because of this common-language bus, any peripheral or device can 'talk' to any other peripheral or device. All translation to and from other languages or codes is done on the printed-circuit input/output cards.

Any peripheral or device that can be interfaced with the coupler/controller may be capable of operation as one or more of the following:



Cover: Represented here by photo blocks are some of the digital devices that can communicate with each other by means of Model 2570A Coupler/Controller. Computers, calculators, stimulus and measuring instruments, data recording and data entry devices, acoustic couplers for time-shared systems, and many others can be building blocks for a variety of systems built around the coupler/controller.

In this Issue:

- A Programmable, Modular, Bidirectional Data Coupler*, by Gibson F. Anderson **page 2**
- Instrumentation Systems Controlled by Time-Shared Computers*, by Neal E. Walko **page 7**
- Measuring Q—Easier and Faster*, by Shiro Kito and Keiichi Hasegawa **page 10**

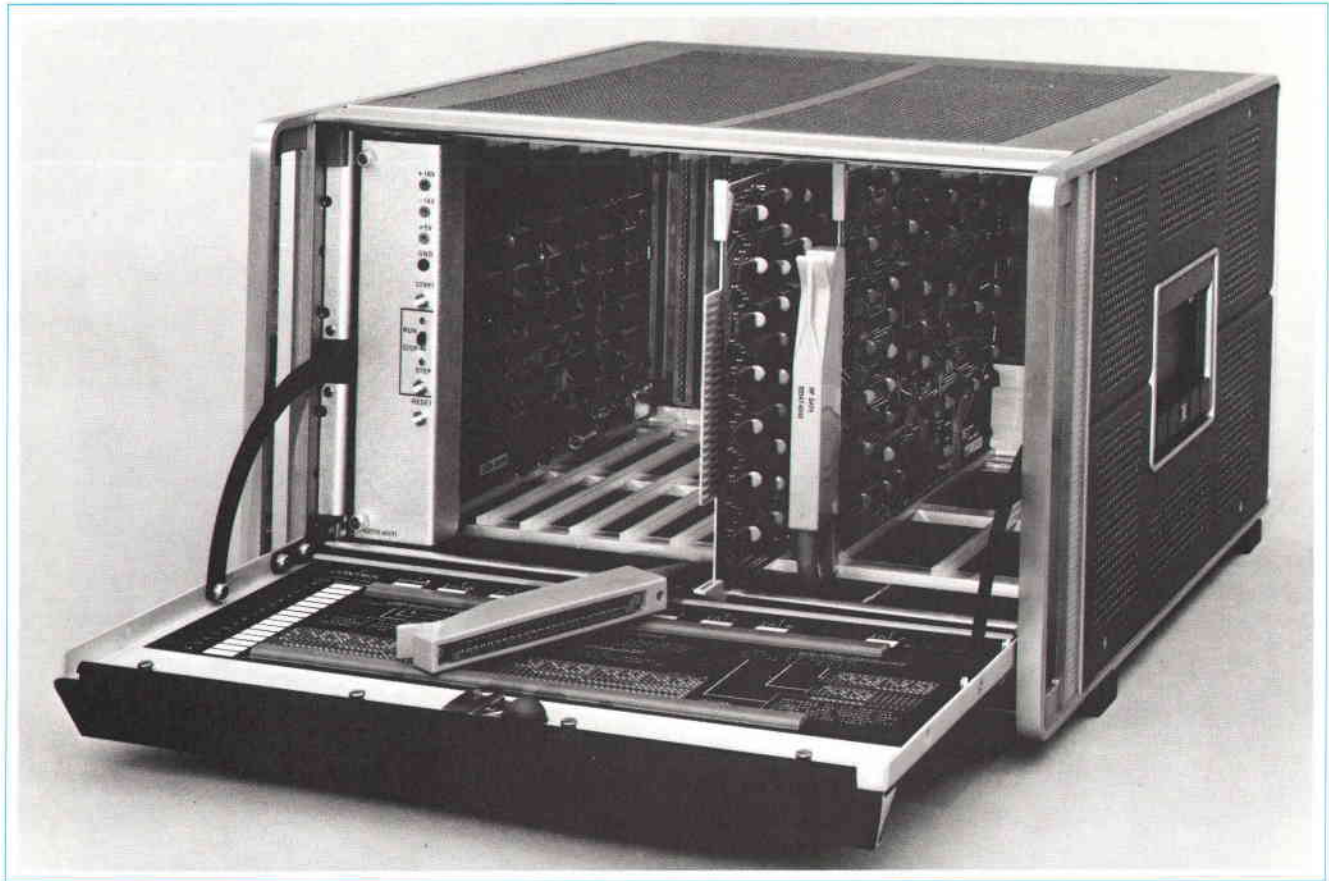

Fig. 1. Model 2570A Coupler/Controller is a programmable two-way data link by which as many as eight digital devices can communicate with each other for purposes of control and data transfer. It can serve as the nucleus of a large number of measurement, control, and data acquisition systems. Plug-in I/O cards connected to instruments, peripherals, and computing machines translate various codes to ASCII. Information is exchanged between cards in ASCII code via a bus in the backplane.

- data sink—a device capable of receiving data from the coupler/controller for display, storage, stimulus of external devices, or analysis
- data source—a device which, upon request, sends data to the coupler/controller
- program source—a device capable of sending commands to the coupler/controller for exercising data sinks or data sources.

Programming

The eight card slots are numbered zero to seven, and a card is addressed by giving its slot number. There are fifteen command characters, A through O, which are decoded on the I/O cards. Command meaning is unique to a card, so the command 'D', for example, can mean different things to different cards. The 8-bit duplex register card used with tape readers, tape punches, and computers has four commands:

I/O Cards Currently Available for Model 2570A Coupler/Controller

- a) BCD Input — interface to digital voltmeters and counters
- b) 40-Bit Output — drives HP 5050B Printer and programs voltmeters and other digitally programmable instruments
- c) Relay Register — sixteen isolated reed relays, fully programmable, for programming power supplies, valves, etc.
- d) Eight-Bit Duplex Register — interface to paper tape readers, punches, and computers
- e) Teletype Card — interface to the HP 2752A and HP 2754A Teleprinters.
- f) Calculator Card — interface to the HP 9100A/B Calculators
- g) Ten-Channel Analog Scanner — used with digital voltmeters for looking at multiple sources with one DVM
- h) Pinboard Program Card — for internal programming
- i) Time-Sharing Interface — interface to acoustic coupler, Bell 103A Dataphone, or equivalent device.

Additional cards are being developed for applications in data communication, data acquisition, automatic test, and automatic measurement and control.

C Take control of coupler/controller and act as program source

I Transmit data to punch or computer until a reverse slash (\) is detected

O Receive data from photoreader or computer until a comma is detected

L Transfer all data and command characters without executing commands. Stop when reverse slash is detected.

Control of the system, or of 'who talks to whom and when' can be vested in any program source: calculator, computer, internal diode pinboard, paper tape, teleprinter, and so on. Control is transferred to a particular source by giving the slot number of the I/O card to which the source is connected, followed by the command letter C. Any program source not connected to the addressed slot then relinquishes control.

When programming from an ASCII source such as a teleprinter, the address and command characters are preceded by an @ symbol. For example, the instruction to cause a digital voltmeter connected to slot number three to 'encode', or take a reading, would be @3E. To transfer control to a computer connected to slot 4, the command would be @4C.

Examples of typical programs appear in Figs. 2, 5, and 6.

How It's Used

The coupler/controller's modular plug-in concept, together with the large number of input/output cards currently available (see table on page 3), make possible a wide range of measurement and control systems. Many of these systems could not be built without the coupler/controller, and many others could be built only at much greater cost.

Coupler/controller systems fall into four principal categories.

- Calculator systems (HP 9100A/B Calculator)
- Time-shared computer systems
- Computer-based systems
- Off-line coupler/controller systems

Calculator Systems

By means of the coupler/controller the HP 9100A/B Calculator can ask for readings directly from digital voltmeters and counters rather than have these readings laboriously keyed into the calculator by the operator. Results of calculations can be printed on a teleprinter or punched on paper tape. Data can be read into the calcu-

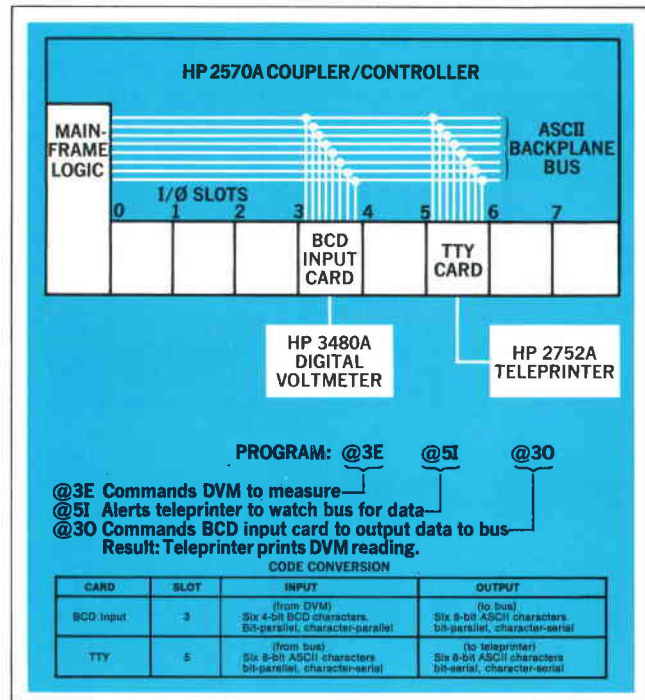

Fig. 2. An example of a coupler/controller program. Each instruction consists of a flag (the ASCII code for @), an address (0-7) and a letter command (A-O). Table shows code conversions done by I/O cards. Programs can come from many sources.

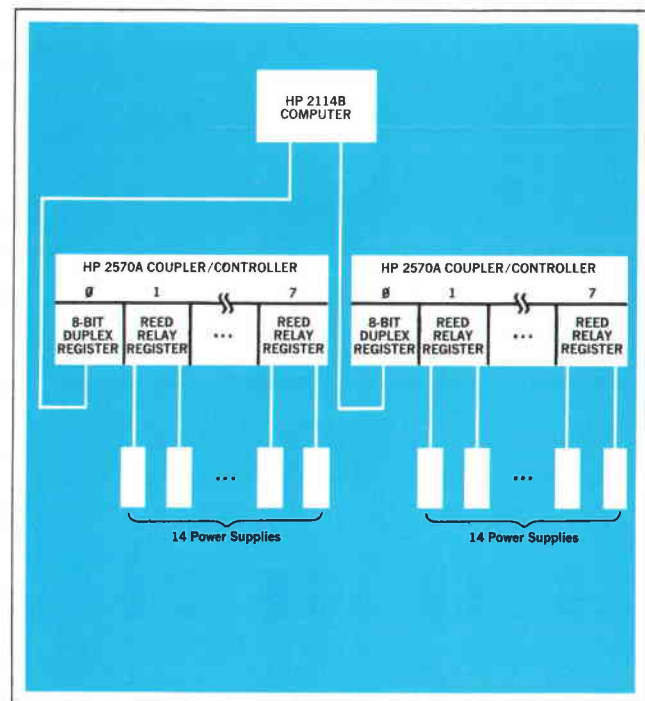

Fig. 3. In this multiple-power-supply programming system the coupler/controller acts as an inexpensive I/O extender for the computer. The system is more economical than others currently available.

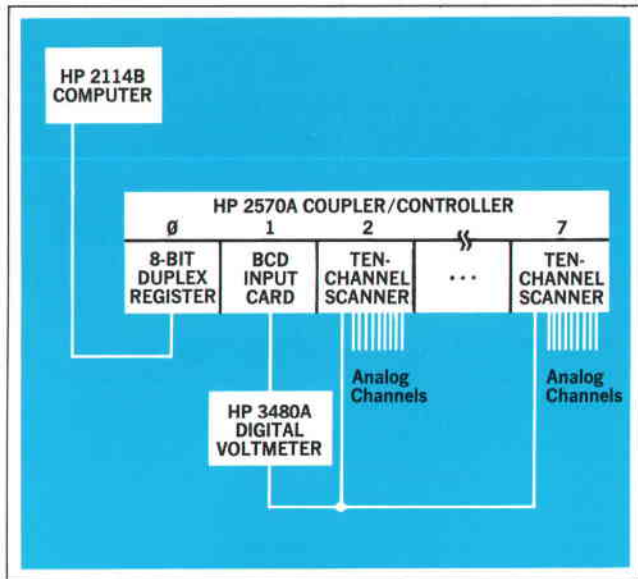

Fig. 4. Here the coupler/controller acts as a remote multichannel analog scanner subsystem to the computer. Applications are in data acquisition and process monitoring.

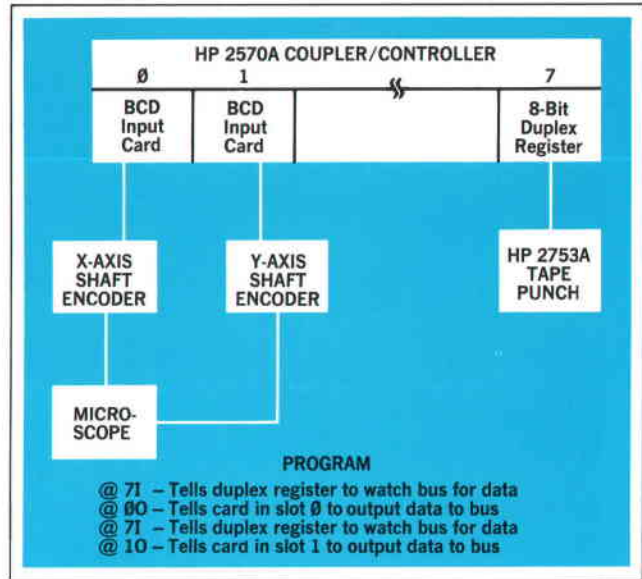

Fig. 5. The coupler/controller can also operate independently of any computing machine. In such applications it is programmed by its internal diode pinboard, by punched tape, or from a teleprinter keyboard. Here it is used to record the positions of objects on a microscope slide.

lator from punched paper tape. The calculator can program conditions externally through a plug-in printed-circuit card that contains 16 programmable isolated reed relays.

Calculator systems based on the coupler/controller will be described in a later issue of the Hewlett-Packard Journal.

Time-Shared Computer Systems

When the coupler/controller is equipped with its plug-in time-sharing interface, tests and experiments can be controlled by a time-shared computer acting through the coupler/controller. Data may be input to the computer program directly, rather than from paper tape or from the teleprinter keyboard. No special software or hardware is required, since the coupler/controller looks like a teleprinter to the time-shared computer. More detail on time-shared computer systems can be found in the article on page 7.

Computer-Based Systems

With its interface to the HP 2114B, 2115A, or 2116B Computers, the coupler/controller can serve as a remote terminal or as an inexpensive I/O extender. Applications lie in such areas as production testing and data acquisition. Figs. 3 and 4 are typical examples of this type of system.

Coupler/Controller Systems

The coupler/controller isn't limited to acting as a coupler to computing machines. It can also be configured as an off-line coupler and controller. Readings from multiple counter installations can be recorded, digital voltmeters can be programmed and their readings recorded on paper tape or a teleprinter, and power supplies can be programmed by the plug-in relay register card. With its 16 isolated programmable reed relays the relay register card can also light lamps, control valves, activate power relays, or perform a multitude of other tasks.

When operating off line, the coupler/controller is programmed by an internal diode pinboard functioning as a changeable read-only memory. For more complicated systems, more diode pinboard programmer cards may be added. Alternatively, the system may be controlled by paper tape or from a teleprinter keyboard.

Figs. 5 and 6 are examples of off-line coupler/controller systems.

Easy to Modify and Service

Because the coupler/controller is a standard ASCII interface, new input/output cards are easily developed and are compatible with all cards previously developed. As new cards are made available or the user's needs increase, he may add I/O cards to his system simply by ordering them and plugging them in. No wiring changes

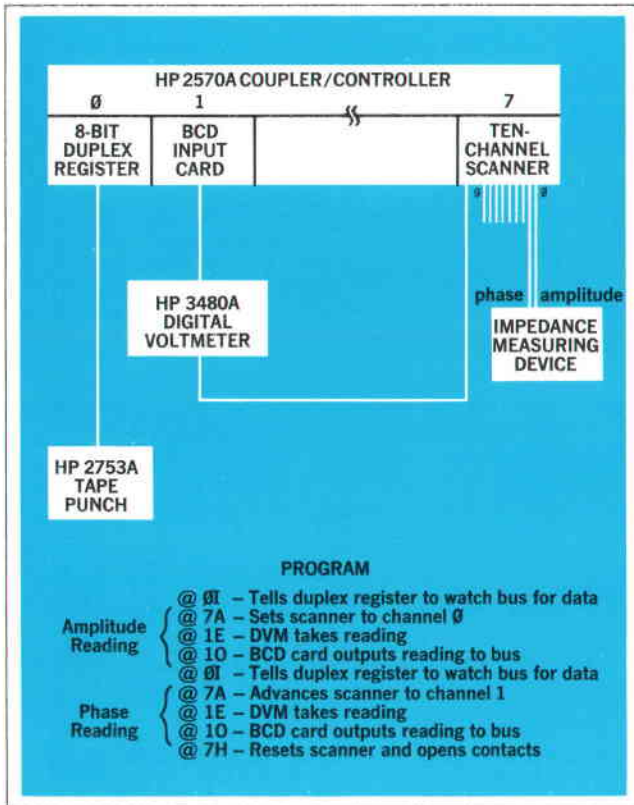

Fig. 6. This system digitizes the analog output of a mechanical-impedance measuring device used in noise-suppression studies. The punched tape is later analyzed by computer.

need be made to the ASCII bus when adding to or reconfiguring the system.

The coupler/controller has many designed-in features which make service easy should it become necessary. The power supply assembly in the rear tilts down for easy access. An optional diagnostic control panel shows the state of all key logic signals by means of HP light-emitting diodes. There is a 5 V connector for the HP 10525A Logic Probe, and the 1 MHz master system clock may be stopped and incremented manually for observation of all logic signals. The system can be serviced in the field with a minimum of equipment.

Acknowledgments

Many people contributed their ideas and effort to develop the 2570A. Bob Knapp and Gene Mieczko made many contributions to the 2570A concept. Geoff Chance and Bob Tinnen lent experience and creativity to defining the interface. Les Moore, Dick Riley, and Jerry Keever designed and tested the mainframe. Neal Walko, Bob Winslow, Jim Wrenn, Bob Tinnen and Alan Richards designed I/O cards.

SPECIFICATIONS

HP Model 2570A Coupler / Controller

INPUT/OUTPUT CODE: ASCII (8-Bit Parallel).

INTERFACING TO DEVICES: Plug-In Circuit Cards.

POWER REQUIREMENTS:

LINE VOLTAGE: 115V ac (2.5A) or 230V ac (1.25A).

VOLTAGE TOLERANCE: $\pm 10\%$

VOLTAGE SELECTOR: Slide switch.

LINE FREQUENCY: 48 to 440 Hz.

POWER CONSUMPTION: 275W (includes power supply loaded to capacity).

OPERATING AMBIENT: Ambient temperature 0° to 50°C (32° to 131°F).
Relative humidity to 95% @ 40°C (104°F).

PHYSICAL DIMENSIONS (Occupies standard 19-inch relay rack).

WIDTH: 19 Inches.

HEIGHT: 10¼ inches.

DEPTH: 20¼ inches (overall).

WEIGHT: Net 42 lb (19 kg), shipping 60 lb (27 kg).

SERVICE ACCESS: Front panel opens to provide access to panel controls. Power supply is hinged to permit access to adjustments and components.

EQUIPMENT SUPPLIED

MAIN FRAME — Model HP 2570A. Includes Plug-In Control Card capable of 15-instruction program; power cord.

OPTIONS

I/O CARD EXTENDER: Part No. 12805A. Provides facility for servicing an I/O card.

CONTROL CARD EXTENDER: Part No. 12806A. Provides facility for servicing a control card.

DIAGNOSTIC CONTROL PANEL: Part No. 12804A. Shows condition of signals on all signal lines; permits visible indication of single cycle completion (5µs cycle); permits single pulse, slows system for complete analysis; brings out all power supplies and ground; provides connector for attaching HP Logic Probe; provides all functions of standard panel supplied with unit.

PRICE: Mainframe \$1625.00. I/O cards \$450 - \$1500.

MANUFACTURING DIVISION: AUTOMATIC MEASUREMENTS DIVISION
395 Page Mill Road
Palo Alto, California 94306

Gibson F. Anderson



Gibson Anderson was project leader for the 2570A Coupler/Controller and is now engineering group leader for development of I/O cards for the same instrument. Gibson received a BA degree in 1963 and a BSEE degree in 1964 from Rice University, and got his MSEE at Stanford University in 1967. Prior to joining HP in 1968, he worked on dictating machines, speech recognition, and small digital machines. According to Gibson, he enjoys skiing, tennis, handball, the pursuits of bachelorhood, music, and frozen juice bars.

Instrumentation Systems Controlled by Time-Shared Computers

A coupler/controller and an acoustic coupler can put a large computer into a system at very low cost.

By Neal E. Walko

THE CONCEPT OF TIME-SHARING made the computational power of large computers accessible to nearly everyone. Now the same concept can be applied to the computerization of control systems, test systems, and systems that collect and process data. Model 2570A Coupler/Controller (see article, page 2), with its time-sharing interface, can communicate with a time-shared computer over telephone lines. Through the coupler/controller, the time-shared computer can interact with and control instruments and other devices. Thus the powerful attributes of a large computer—mass data storage, mass program storage, data manipulation and analysis, prewritten statistical routines and many other library routines, decision-making and system control based on measured data—are no longer confined to large sophisticated systems. Even simple systems can be augmented with these capabilities at the relatively low cost of a time-sharing terminal.

With the time-sharing card installed, the coupler/controller can interface with any time-shared system capable of communicating over voice-grade telephone lines with an acoustic coupler, a Bell 103A Dataphone, or an equivalent device using the American Standard Code for Information Interchange (ASCII). Communication is two-way; that is, the coupler/controller and the computer can send and receive information at ten characters per second in either half-duplex or full-duplex mode. The interface is as described in specification RS-232 of the Electronic Industries Association (EIA). In practical terms, this means the coupler/controller will operate with nearly all time-shared systems and with nearly all time-sharing languages, including FORTRAN and BASIC.

Operation with Computer

There are three possible modes of operation for any device connected to the coupler/controller, including the time-shared computer. A device is a data sink, a data source, or a program source. As a program source, the computer sends commands to the coupler/controller in

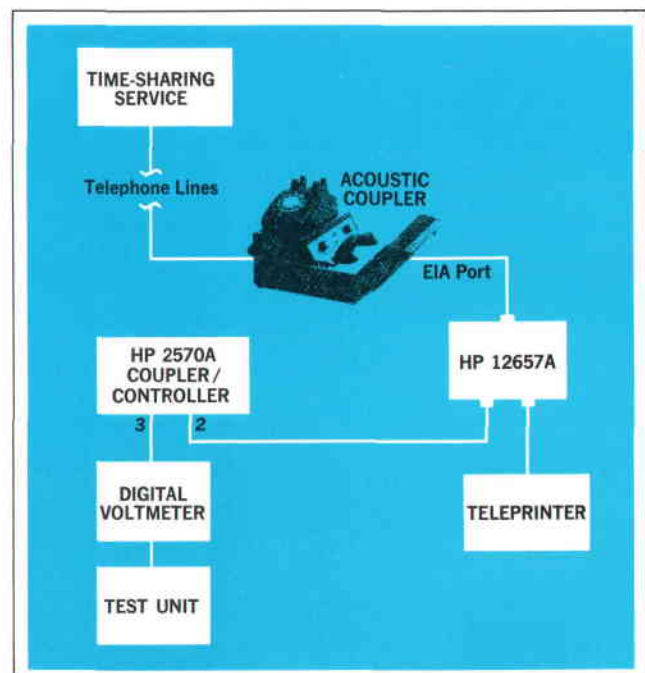

Fig. 1. Model 2570A Coupler/Controller acts as a data link between instruments and time-shared computers, so even a simple system can have the benefits of computer control and data processing at the relatively low cost of a time-sharing terminal. In this example, the average of several digital voltmeter readings is computed and printed out.

```

RUN

@3E@2I@7C
?-21433E-4
@3E@2I@7C
?-18904E-4
@3E@2I@7C
?04732E-4
@3E@2I@7C
?31426E-4
@3E@2I@7C
?57281E-4

AVERAGE VALUE= 1.06204

DONE

```

Fig. 2. Printout from the system of Fig. 1. The printed average is of five DVM readings.

ASCII code. As a data sink it receives data from the coupler/controller for analysis and/or storage. As a data source, it sends data to the coupler/controller for display or programming of stimuli.

Programming Commands

The general form of a command for a coupler/controller peripheral is `@ ac`

where `@` is the ASCII code for the '@' symbol, `a` is the address or I/O slot number of the peripheral, and `c` is the command code. The address `a` is a number between 0 and 7 and the command `c` is a letter between A and O. For example, to cause a digital voltmeter connected to I/O slot 3 to make a measurement, the command is `@3E`. E is the command letter for 'encode'.

To show how the computer is programmed to send such a command, an example in the BASIC language will be used. However, the same principles apply to the other languages as well.

The BASIC program statement that causes the computer to send information to a terminal is a PRINT statement. Therefore, to issue the command `@3E` to the coupler/controller, the program statement would be

```
PRINT "@3E"
```

Transmitting data to the coupler/controller, is similar to transmitting commands. If a stored value of X is to be sent to the coupler/controller, a PRINT X; "," statement is all that is required. Upon execution of this statement, the computer will output the value of X followed by a comma (,). The comma tells the coupler/controller when the last data character has been transmitted.

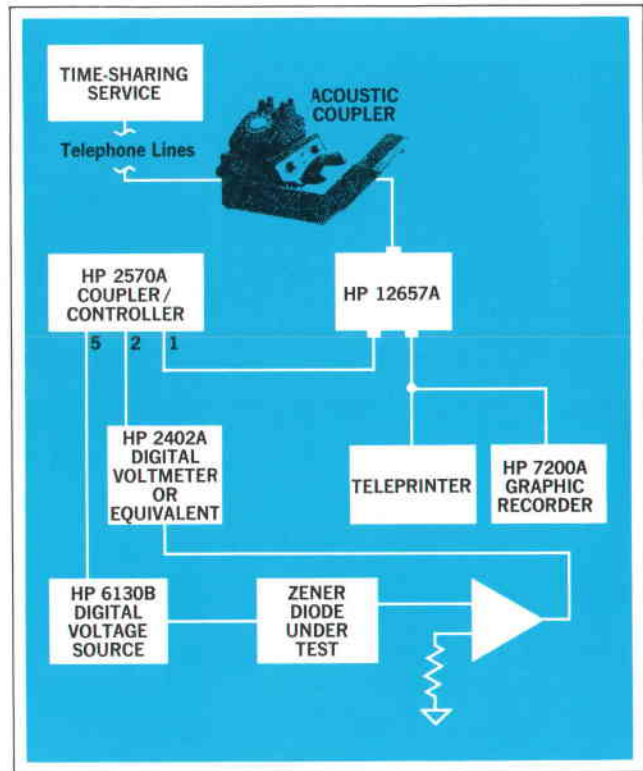

Fig. 3. A system for measuring and plotting the characteristic I-V curve of a Zener diode.

Transmission of data to the computer is accomplished by commanding any coupler/controller peripheral capable of being a data source to transmit data, and then following the command statement with a computer input statement. For example, if the digital voltmeter associated with slot 3 is to transmit its encoded value to the computer, the voltmeter output command is followed in the BASIC program by the statement INPUT X, which causes the computer to receive the transmitted data.

Examples

Consider the system configuration shown in Fig. 1, and assume the task is to take five readings of the DVM associated with I/O slot 3 and print the average on the teleprinter associated with I/O slot 2. An accessory, Model 12657A, is used to connect the teleprinter to the acoustic coupler in parallel with the coupler/controller.

A BASIC computer program that would exercise the system of Fig. 1 would be as follows.

```

10 LET S=0
20 FOR I=1 TO 5
30 PRINT "@3E@2I@7C"
40 INPUT X
50 LET S=S+X

```

```

60 NEXT I
70 LET A = S/5
80 PRINT "AVERAGE VALUE = "; A
90 END

```

The command @3E causes the DVM in slot 3 to measure, and the command @2I alerts the teleprinter that input is coming. The third command, @7C, turns over control to the internal diode pinboard which gives the

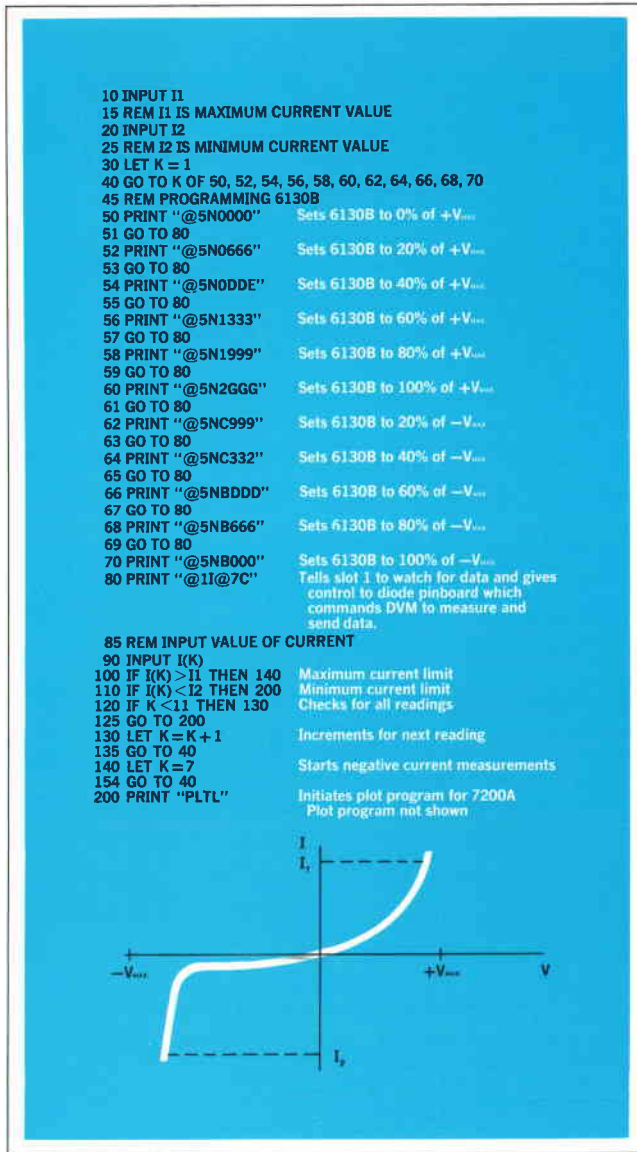

Fig. 4. BASIC program to operate the system of Fig. 3, and a typical graphic result. The HP 6130B is controlled by a 16-bit relay register which is programmed by the four alphanumeric characters following @5N in every other statement between 50 and 70. Each character sets four relays. This isn't the only way to write this program, but it turns out to be the shortest when there are relatively few test voltages.

DVM card an output command and then supplies a carriage-return signal to the computer to signify the end of the data string. Fig. 2 shows a typical printout generated by this program.

Fig. 3 is an example of another application. This system automatically programs the voltage across the Zener diode over a specified positive and negative voltage range. The DVM senses the output of the operational amplifier which measures the current through the Zener diode. At the completion of measurement, the diode's characteristic I-V curve is plotted on the HP 7200A Graphic Recorder. Programming of the HP 6130B digital voltage source can be either absolute or based on the values recorded by the DVM.

A BASIC program for this system is shown in Fig 4. The voltage across the diode is varied in 20% increments of the maximum positive and negative values. The corresponding values of current—within the specified limits I1 and I2—are stored and then plotted on the HP 7200A Graphic Recorder.

Acknowledgments

Thanks are due Gibson Anderson for his help in resolving 2570A/computer language interface problems. John Wiese also contributed a great deal in the study of the techniques required to input data to the computer. Important marketing suggestions were supplied through the diligent efforts of James Willenborg. Too numerous to name but nevertheless indispensable are the many people involved in layout, expediting, and manufacturing.

Neal E. Walko



Neal Walko got his BSEE degree at the University of Pittsburgh in 1960 and his MSEE degree at Pennsylvania State University in 1963. Before coming to HP in 1969, Neal worked on the design, production, and testing of microwave receivers and PCM telemetry equipment. He was project leader for the time-sharing interface for the 2570A Coupler/Controller.

Neal's spare time is time-shared, too, between teaching and relaxation. He teaches electronics and math at West Valley College, Foothill College, and San Jose City College, and he must be one of very few engineers who hold a California State Standard Designated Teaching Credential. For relaxation, it's sailing, gardening, chess, or the study of classical music.

Measuring Q—Easier and Faster

Thirty-five years later, Q measurements become easier, with greater Q range and over wider bands.

By Shiro Kito and Keiichi Hasegawa

PERFECT COMPONENTS, ideally reactive or ideally resistive, rarely exist. Electronic circuit elements generally consist of reactance and resistance in various combinations. The ratio of a component's reactance to its resistance is measured by the Q meter and the magnitude of Q is generally considered a figure of merit expressing the ability of a component to store energy compared to the energy it wastes.¹ A measure of Q is important to determine the RF resistance of components, the loss angle of capacitors, dielectric constants, transmission line parameters and antenna characteristics.

Q is a dimensionless number. In a circuit at resonance, Q can be defined as the ratio of total energy stored to the average power dissipated per cycle. For a single reactance component:

$$Q = \frac{X_s}{R_s} = \frac{R_p}{X_p}$$

where X_s and X_p are series and parallel reactance, and R_s and R_p are series and parallel resistance. The most common form of Q meter uses a series resonant circuit to measure Q, Fig. 1. When the variable air capacitor C is adjusted so that $X_c = X_L$, the only remaining impedance in the loop is R_s . The current that flows then is

$$i = \frac{e}{R_s},$$

and the voltage E across capacitor C is

$$E = \frac{e}{R_s} \cdot X_c \text{ and } \frac{E}{e} = \frac{X_c}{R_s} = \frac{X_L}{R_s} = Q.$$

Therefore, if e is held at a constant, known level, a voltmeter with high input impedance can be connected across

the capacitor and calibrated directly in terms of Q. The e values in the above equations are functions of selected Q ranges. R_s is a function of the unknown inductor or Q reference coils.

Since the mid-1930's, the Boonton Q Meter (now the HP Model 260A Q Meter) has been an easy and common means of measuring Q. To make Q measurements even less complicated and make them over a wider range, a new instrument, the HP Model 4342A, Fig. 2, was designed. It is all solid state and covers a Q range from 5 to 1000 in a frequency band from 22 kHz to 70 MHz. Pushbutton controls and automatic leveling eliminate many dial adjustments and reduce measurement time. The fragile thermocouple element which was subject to accidental burnout in the Model 260A has been eliminated.

Basic Operation

The measurement principle used in the Model 4342A is the series resonant circuit. A block diagram of the Q Meter is shown in Fig. 3. The oscillator, which covers 22 kHz to 70 MHz, is automatically leveled by a loop consisting of the detector and the ALC amplifier. The oscillator output is controlled automatically by comparing it to a fixed dc level.

Thus, constant voltage is supplied to the Q-range attenuator. The attenuator adjusts the signal level according to the range settings. This signal is fed into the resonance circuit by a transformer (sometimes called an injection transformer).

Resonance is achieved by adjusting the variable capacitor, and this level is read by the high-impedance voltmeter. Thus the Q value of the resonant circuit is indicated on the meter.



The classic Boonton Q Meter, now the HP Model 260A, has been redesigned with an extended Q range and circuit improvements that make it faster and easier to use.

Injection System

In the older Model 260A Q Meter, a known current monitored by the thermocouple ammeter is injected into a resonant circuit through a low value resistor R_m , Fig. 4(a). This results in known voltage e in series with the resonant circuit. At resonance, $Q = E/e$. Voltage E is read by the voltmeter which can be calibrated in terms of Q . This system has some disadvantages:

- The current through R_m must be monitored as frequency is varied, and must be adjusted to an index mark on the meter.
- It is often necessary to readjust the level at resonance because of interaction between the resonant circuit and the oscillator output circuit.
- Thermocouples do not respond fast and can be damaged by overcurrent.

■ The injection resistor R_m contributes to errors when measuring a high Q circuit. For example, if R_m is 20 milliohms, the Q of the inductor is 500, resonated capacitance is 100 pF at 50 MHz, then series reactance of 100 pF at 50 MHz is 32 ohms. $R_s = X_s/Q = 32/500 = 64$ milliohms. So an R_m of 20 milliohms is a 31% error! The skin effect of R_m also contributes to the error.

To overcome these disadvantages, the new Model 4342A uses a method that injects a constant voltage through a transformer which has very low output impedance, Fig. 4(b). The transformer has a toroidal core, and nearly flat frequency response from 22 kHz to 70 MHz. A clever scheme for using the LO terminal as a one-turn secondary winding results in very low output impedance, of the order of 1 milliohm. High measurement accuracy is thus achieved.

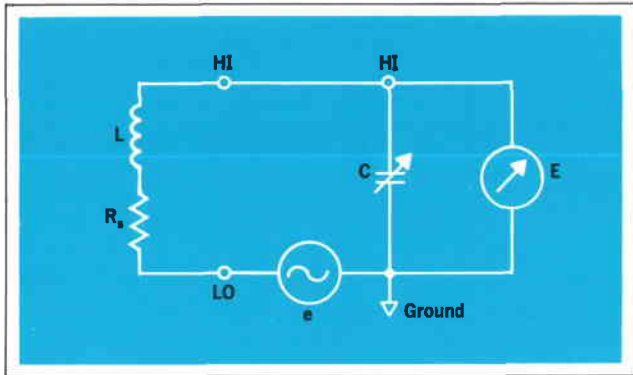

Fig. 1. A series resonant circuit is the basis of Q measurement.

Tuning Capacitor

Sometimes called the Q capacitor, an important component of the Q meter is the tuning capacitor, Fig. 5. It is the reactance standard in the Q measurement. Because the Q capacitor can be calibrated precisely, the Q meter provides direct reading of inductance in addition to Q.

To achieve this high accuracy, the capacitor is designed with low loss and low residual inductance. Minimum capacitance is low to maintain accuracy at high frequencies. These results have been attained by:

- Highly polished, silver and gold plated surfaces of both stator and rotor.

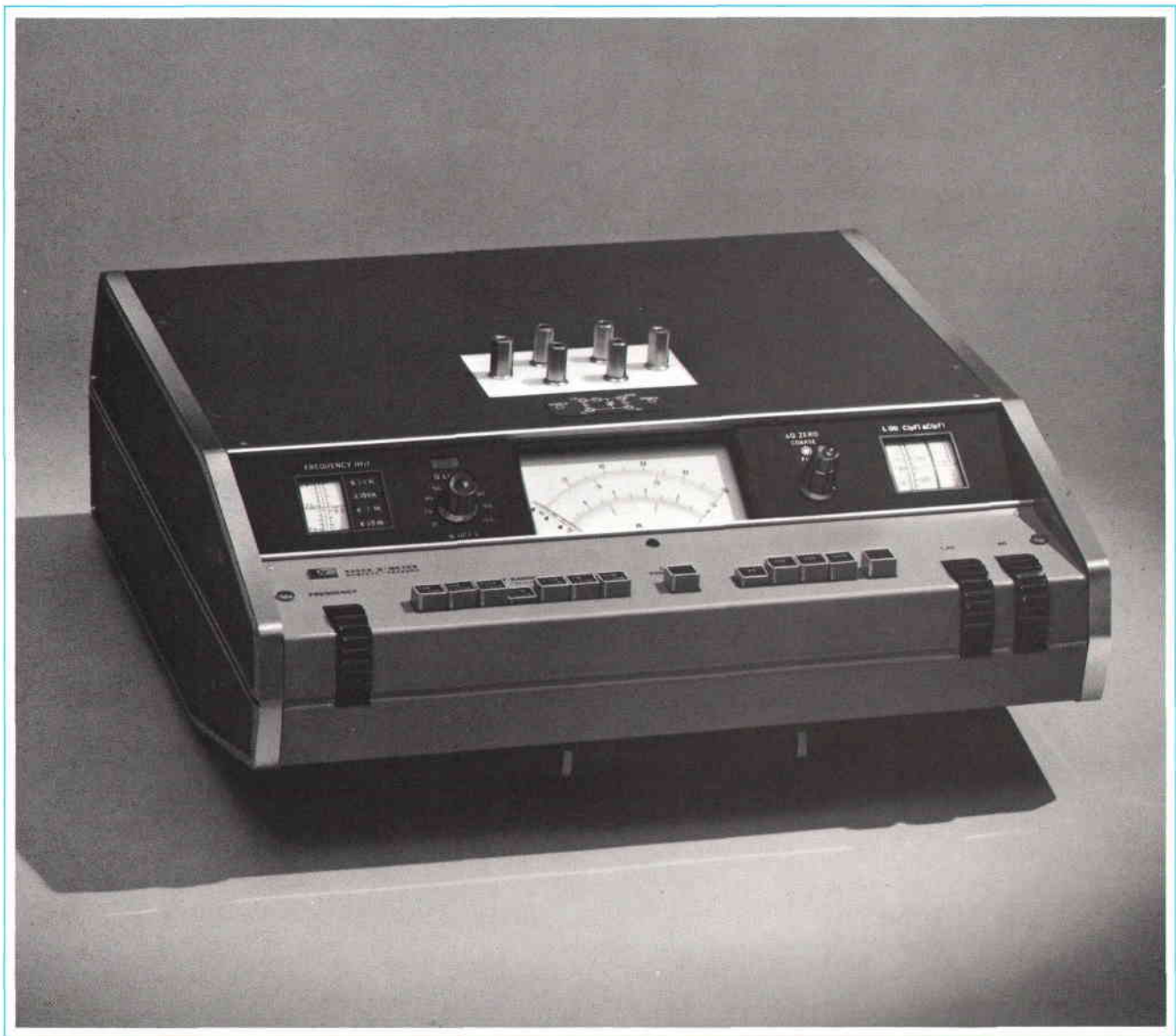

Fig. 2. Pushbutton controls simplify Q measurements with the new HP Model 4342A Q Meter. Q from 5 to 1000 can be measured in a frequency band from 22 kHz to 70 MHz.

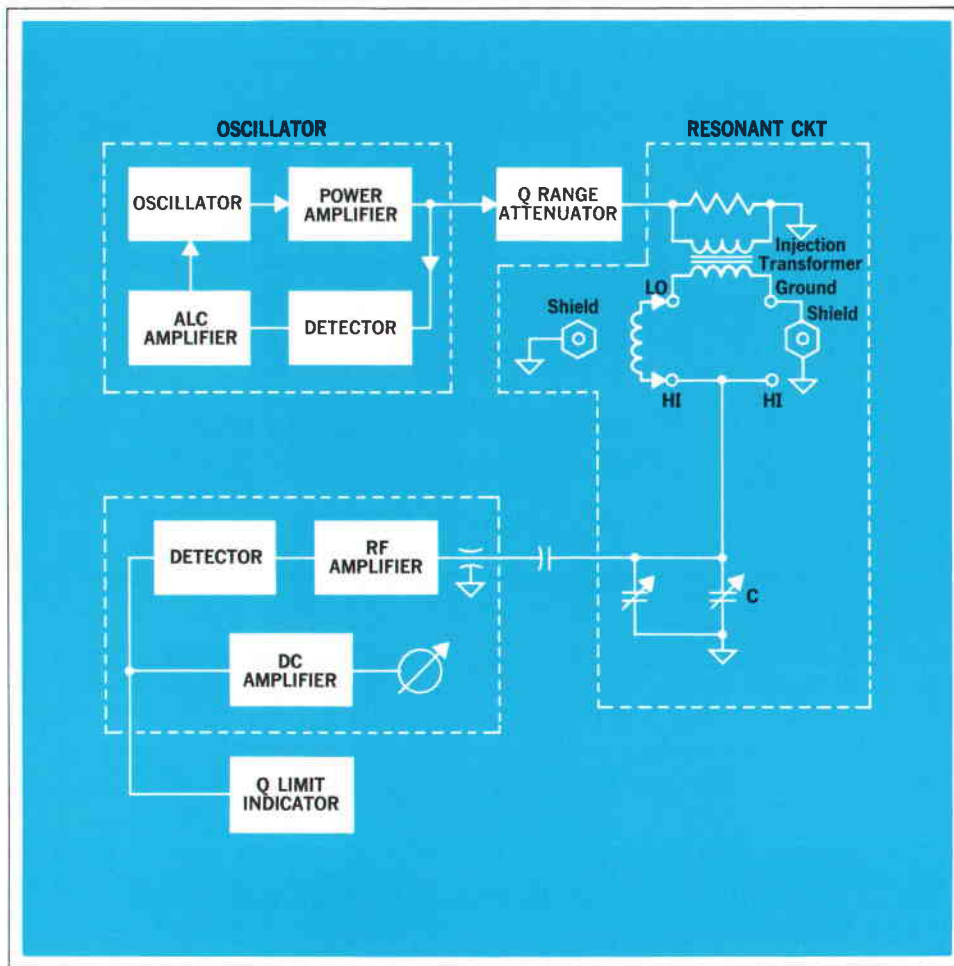

Fig. 3. Three basic parts make up the Q meter: the oscillator with leveled output, a high impedance Q voltmeter, and the resonant circuit.

- Short current paths for minimum residual inductance.
 - Low contact resistance between HI terminals and stator.
 - A solid, low-loss support for the insulator.
- The Q capacitor covers the range from 20 pF to 475 pF. Residual inductance is less than 10 nH.

High-Z Voltmeter

A stable, solid-state voltmeter also contributes to the accuracy of the Q meter. It uses a field-effect transistor input and feedback for high-impedance input over the frequency range 22 kHz to 70 MHz. A capacitor divider, Fig. 6, connected to the Q capacitor stator, also increases the voltmeter input impedance. From Fig. 6, it can be shown that

$$R_p \cong R_2 \left(1 + \frac{C_2}{C_1}\right)^2 \quad (1)$$

$$C_p \cong \frac{C_1 \cdot C_2}{C_1 + C_2} \quad (2)$$

From Eq. 1, R_2 is increased by $\left(1 + \frac{C_2}{C_1}\right)^2$ times by the capacitor divider. In the Model 4342A, C_1 and C_2 are chosen to make this factor about 33, so that $R_p \cong R_2 \times 10^3$. Thus, the input conductance of the voltmeter is lowered by a factor of 1000, and it affects the Q capacitor very little. In addition, C_1 is a low-loss, guarded capacitor, and its effect on the Q capacitor is also negligible.

The voltmeter circuit contains an RF amplifier with a gain of about 50. It raises the signal level in the detector so that the input to the dc amplifier is maintained at a high level. This plus a differential amplifier using a compound FET connection provides stable operation. Zero adjustment of the instrument between measurements is not required.

Measuring Unknowns

There are three methods of connecting components to the measuring circuit of the Q meter:

Direct connection. Inductances from 0.09 μ H to about 1.2H are measured by connecting them directly to the COIL terminals, Fig. 7(a). The circuit is resonated by

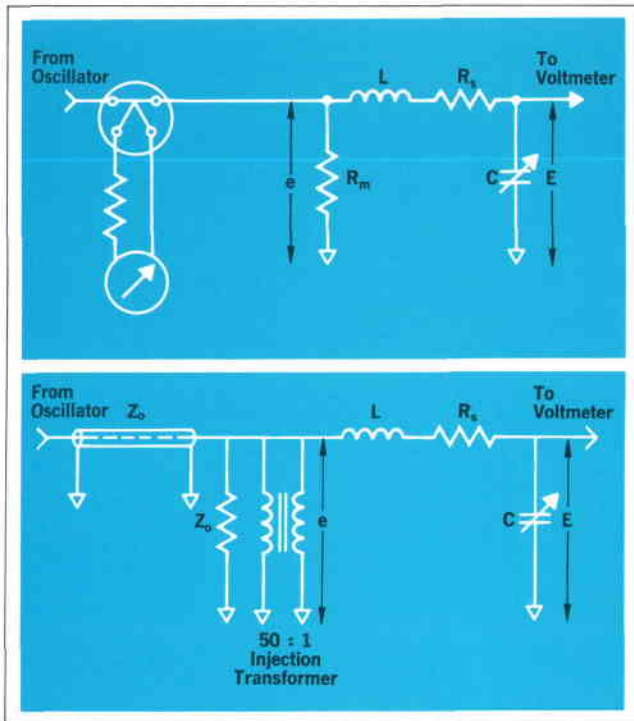

Fig. 4. Constant current injection system (a) used in the older Model 260A Q meter uses a thermocouple that can be easily damaged. Constant voltage injection system (b) used in the new Model 4342A Q Meter uses a transformer with an output impedance of only 1 milliohm.

adjusting either capacitance or frequency and Q is read on the meter. Inductance may be read on the L scale by first setting the frequency dial to L. Inductances from 1200 mH to 90 nH may be read.

Parallel connection. High impedance components, such as high value resistors and low value capacitors are connected in parallel with the capacitor, Fig. 7(b). Before the component is connected, the circuit is resonated using a reference coil. When the component under test is connected, the change in Q is combined with the reference values to yield the parameters of the unknown. Very small changes in Q are read using the ΔQ function, which increases resolution 10 times. Its lowest range is 0 to 3.

Series connection. Low impedance components are measured in series with the measuring circuit, Fig. 7(c). The component under test is connected in series with a reference coil. By closing and opening a shorting bar, the unknown is evaluated.

GO/NO-GO Test

A Q-limit selector on the front panel of the Model 4342A sets a Q limit as a percentage of full scale reading, Fig. 8. For production testing, the indicator lamp on the front panel is a faster and easier indication than reading the meter.

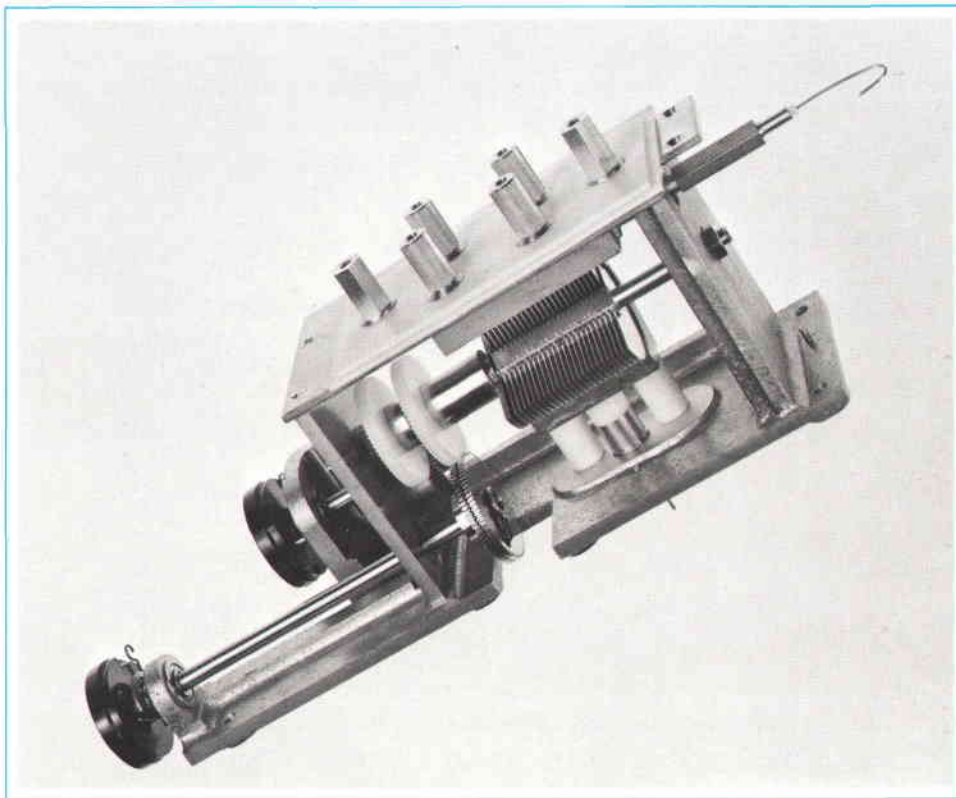

Fig. 5. This precision tuning capacitor is the reactance standard in the instrument.

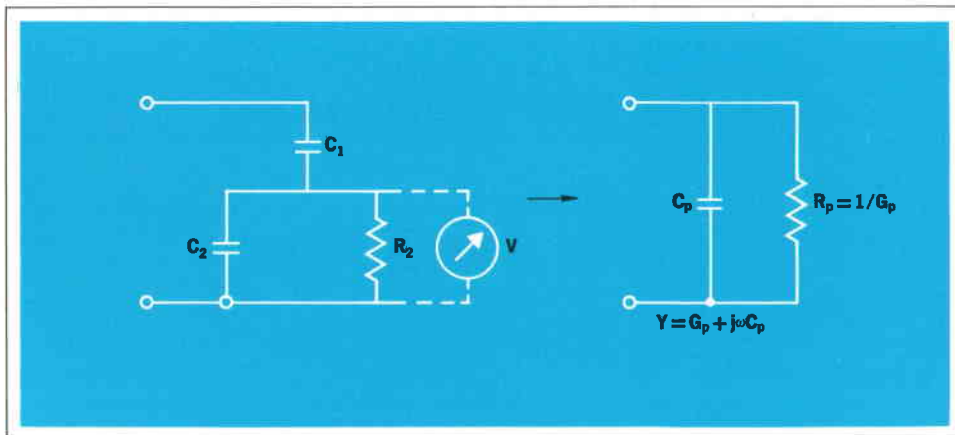

Fig. 6. Capacitance divider (left) and its equivalent circuit (right) increases the Q voltmeter input impedance.

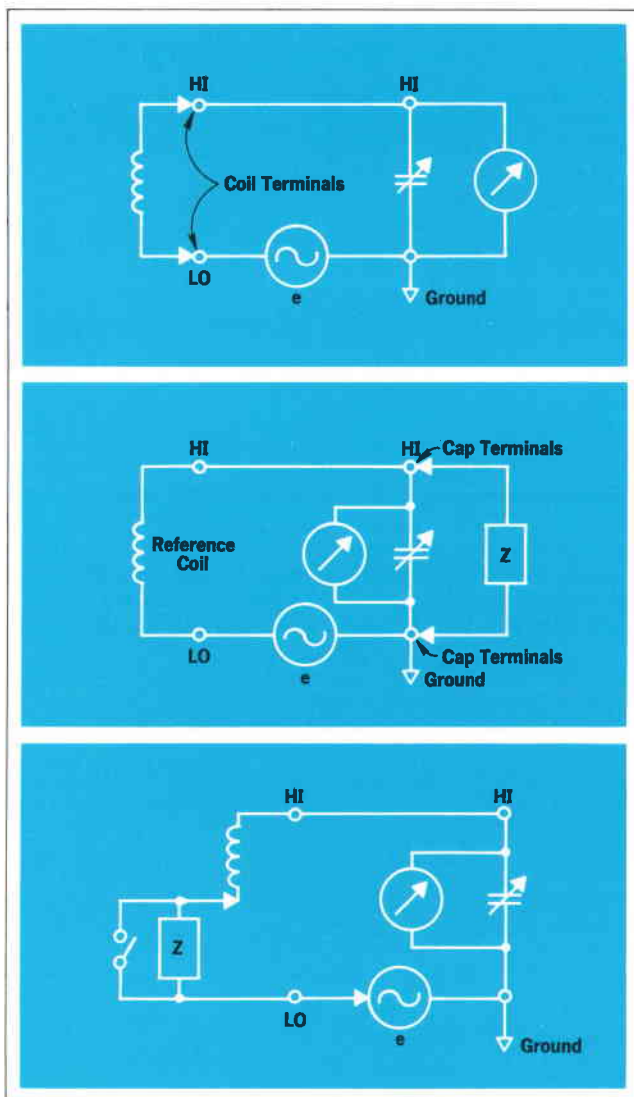

Fig. 7. Three ways in which components are measured with the Q meter. Most components in the medium inductance range ($0.09 \mu\text{H}$ to 1.2 H) are connected directly (a). High impedance components are connected in parallel (b) with the capacitor, and low impedance components use the series connection (c).

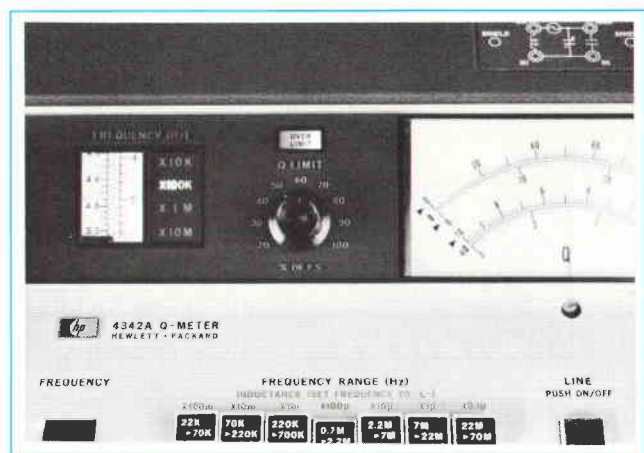

Fig. 8. Limit is set as a percentage of full scale. A lamp indicates Q over the limit.

Reference Coils

For series and parallel measurements, reference coils are required. Twenty coils are available for the frequency range from 22 kHz to 70 MHz. The Q of the coils is about 270, and all are shielded for stable operation.

Acknowledgments

The authors wish to acknowledge the contributions of: Tomo Matsuzawa who did the design of the tuning capacitor; Toshio Manabe who did the mechanical design; Kazu Shibata who did the industrial design. Others associated with the project include Asahiko Sawaki, Izumi Shiode and Kimijiro Kikuchi.

Invaluable contributions were also given by Giichi Yokoyama, Nobuo Numasaki, John Lark, Karl Schwartz, and Art Fong. Many others in the former Rockaway Division provided much useful information.

Reference

1. Charles G. Gorss, 'Methods of Measuring Impedance,' *Hewlett-Packard Journal*, Jan. 1967.

SPECIFICATIONS

HP Model 4342A Q Meter

RF CHARACTERISTICS

RF RANGE: 22 kHz to 70 MHz in 7 bands: 22 to 70 kHz, 70 to 220 kHz, 220 to 700 kHz, 700 to 2200 kHz, 2.2 to 7 MHz, 7 to 22 MHz, 22 to 70 MHz.

RF ACCURACY: $\pm 1.5\%$ at 22 kHz to 22 MHz.
 $\pm 2\%$ at 22 MHz to 70 MHz.
 $\pm 1\%$ at 'L' point on Frequency Dial.

RF CALIBRATION: Increments of approximately 1%.

Q MEASUREMENT CHARACTERISTICS

Q RANGE: 5 to 1000 in 4 ranges: 5 to 30, 20 to 100, 50 to 300, 200 to 1000.

Q ACCURACY: % of indicated value (at 25°C)

Q	22 kHz-30 MHz	30 MHz-70 MHz
5-300	± 7	± 10
300-600	± 10	± 15
600-1000	± 15	± 20

Q CALIBRATION: Upper scale: increments of 1 from 20 to 100, lower scale: increments of 0.5 from 5 to 30.

ΔQ RANGE: 0 to 100 in 4 ranges: 0 to 3, 0 to 10, 0 to 30, 0 to 100.

ΔQ ACCURACY: $\pm 10\%$ of full scale.

ΔQ CALIBRATION: Upper scale: increments of 0.1 from 0 to 10, lower scale: increments of 0.05 from 0 to 3.

INDUCTANCE MEASUREMENT CHARACTERISTICS

L RANGE: 0.09 μ H to 1.2 H, direct reading at 7 specific frequencies.

L ACCURACY: $\pm 3\%$ after substitution of residuals (approx. 10 nH).

RESONATING CAPACITOR CHARACTERISTICS

CAPACITOR RANGE: Main: 25 to 470 pF; vernier: -5 to +5 pF.

CAPACITOR ACCURACY: Main: $\pm 1\%$ or 1 pF, whichever is greater; vernier: ± 0.1 pF.

CAPACITOR CALIBRATION: Main: 1 pF increments, 25 to 30 pF, 2 pF increments 30 to 200 pF, 5 pF increments 200 to 470 pF; vernier: 0.1 pF increments

ACCESSORIES AVAILABLE

REFERENCE INDUCTORS
Q-STANDARDS
AUXILIARY CAPACITOR
SERIES LOSS TEST ADAPTER

GENERAL

TEMPERATURE RANGE: 0°C to 50°C.

WEIGHT: Approx. 31 lbs (14 kg).

POWER: 115 or 230 V $\pm 10\%$, 50-400 Hz, approx. 25 W.

PRICE: \$1500.

MANUFACTURING DIVISION: YOKOGAWA-HEWLETT-PACKARD LTD.

9-1, Takakuracho
Hachioji-shi
Tokyo, 192, Japan.

Shiro Kito



Shiro Kito received his BSEE degree from Keio University in 1959. Before joining YHP in 1964, he worked on the development of oscilloscopes at Yokogawa Electric Works. From 1966 to 1968 he was in the Colorado Springs Division as a circuit designer of the 1803A. Then he joined the 4342A project as a designer of the RF voltmeter and became a project leader in December 1969. He is presently one of the R&D section managers for

YHP. Shiro enjoys classical music and plays the violin.

Keiichi Hasegawa



Keiichi Hasegawa joined Yokogawa Electric Works (YEW) in 1943 after graduating from Tokyo Electrical Engineering College. Before joining YHP in 1964, he spent 21 years with YEW as an R&D engineer and production supervisor. At YHP he was a supervisor of manufacturing engineering and production. Then he transferred to R&D and was project leader and the designer of the 4342A Oscillator circuitry. Since late 1969 he has

been R&D section manager of YHP, responsible for electro-mechanical design.

Keiichi is an expert at tennis, which he enjoys in his spare time.

HEWLETT-PACKARD JOURNAL SEPTEMBER 1970 Volume 22 • Number 1

TECHNICAL INFORMATION FROM THE LABORATORIES OF THE HEWLETT-PACKARD COMPANY PUBLISHED AT 1501 PAGE MILL ROAD, PALO ALTO, CALIFORNIA 94304
Editor: R. H. Snyder Editorial Board: R. P. Doan, L. D. Shergalis Art Director: Arvid A. Danielson Assistant: Maridel Jordan

HP Archive

This vintage Hewlett-Packard document was
preserved and distributed by

www.hparchive.com

Please visit us on the web!

On-line curator: John Miles, KE5FX

jmiles@pop.net

