

HEWLETT-PACKARD JOURNAL



FEBRUARY 1970

A System for Automatic Network Analysis

By Douglas Kent Rytting and Steven Neil Sanders

WITH THE ADVENT OF new, highly sophisticated microwave devices and systems, there has developed a need for fast, accurate, and complete characterization of the networks that comprise them. Two popular techniques exist for characterization of microwave networks. They can be broadly classified as fixed-frequency or swept-frequency techniques. The power of the fixed-frequency technique is that the mismatch, tracking, and directivity errors of the measurement system can be minimized by 'tuning out' the residual errors, achieving high accuracy. Fixed-frequency techniques, however, are slow and somewhat tedious. Swept-frequency techniques in general offer a fast means of gathering data across broad bandwidths, and the advantage of intuitive insight into the device being tested. Normally, it is difficult to account for all errors, when using the swept-frequency technique, since they can not be completely 'tuned out' in the broadband case. The question is, can we somehow devise a microwave measurement system which will provide the advantages of the above two techniques without incurring any of the disadvantages? Before answering, let's take a broader look at the total microwave measurement field.

What should we list as desirable characteristics of a microwave measurement system?¹

1. Complete device characterization capability
 - a. linear (amplitude and phase)
 - b. non-linear
 - c. noise
2. Accuracy
3. Speed
4. Flexibility
5. Ease of use

A system aimed at achieving many of these characteristics is the HP Model 8542A Automatic Network Analyzer shown in Fig. 1. The effort has been to combine the advantages of the fixed-frequency and swept-frequency

techniques. The Automatic Network Analyzer uses a stepped-CW sweep rather than a continuous one, so a finite number of points for measurement and error correction results. Instead of tuning-out the system errors at each frequency point, the systematic internal errors are first measured, then taken into account as the device is measured. The internal system errors are vectorially subtracted from the measurement data, correcting the measurement and leaving only the true characteristics of the device. System errors need only be characterized at the *beginning* of a set of measurements. A complete error model of the Automatic Network Analyzer can be constructed by measuring appropriate standards. The stand-



Cover: Automatic network analyzer systems can vary widely, depending on the uses to which they are to be put. This one can show its findings on large-screen oscilloscope, on scope faces of more usual size, by teleprinter, and by X-Y plot. The power of these systems has produced a revolution in

microwave engineering. Our authors tell how it is that this is so.

In this Issue:

- A System for Automatic Network Analysis, by Douglas Kent Rytting and Steven Neil Sanders page 2*
- Software for the Automatic Network Analyzer, by William A. Ray and Warren W. Williams page 11*
- Developing Accuracy Specifications for Automatic Network Analyzer Systems, by B. P. Hand page 16*
- Applications for the Automatic Network Analyzer, by Brian Humphries page 20*

ards used are such devices as shorts, opens, and sliding loads, which are relatively easy to characterize and manufacture to accurate tolerances.

To recap, the system measurement procedure is as follows: 1) calibration, 2) measurement, and 3) correction of the data.

Clearly, data storage and mathematical manipulation are required. A relatively small instrumentation computer will provide this function elegantly.² Blending the microwave instruments, computer, and software programming will yield a powerful and flexible system which well achieves many of the desired characteristics.

1. Linear device characterization.

What is the best way to characterize a microwave network? There are many sets of parameters available. The $[z]$, $[h]$, $[y]$, $[ABCD]$ matrices are popular low-frequency characterizations. In recent years a set has been developed that is more practical, easier to use, and easier to measure at microwave frequencies. This set is the family of s -parameters.³ They need not be confined to microwaves, being also valid to represent networks at low frequencies.

2. Accuracy

To insure that the error-correcting procedure is

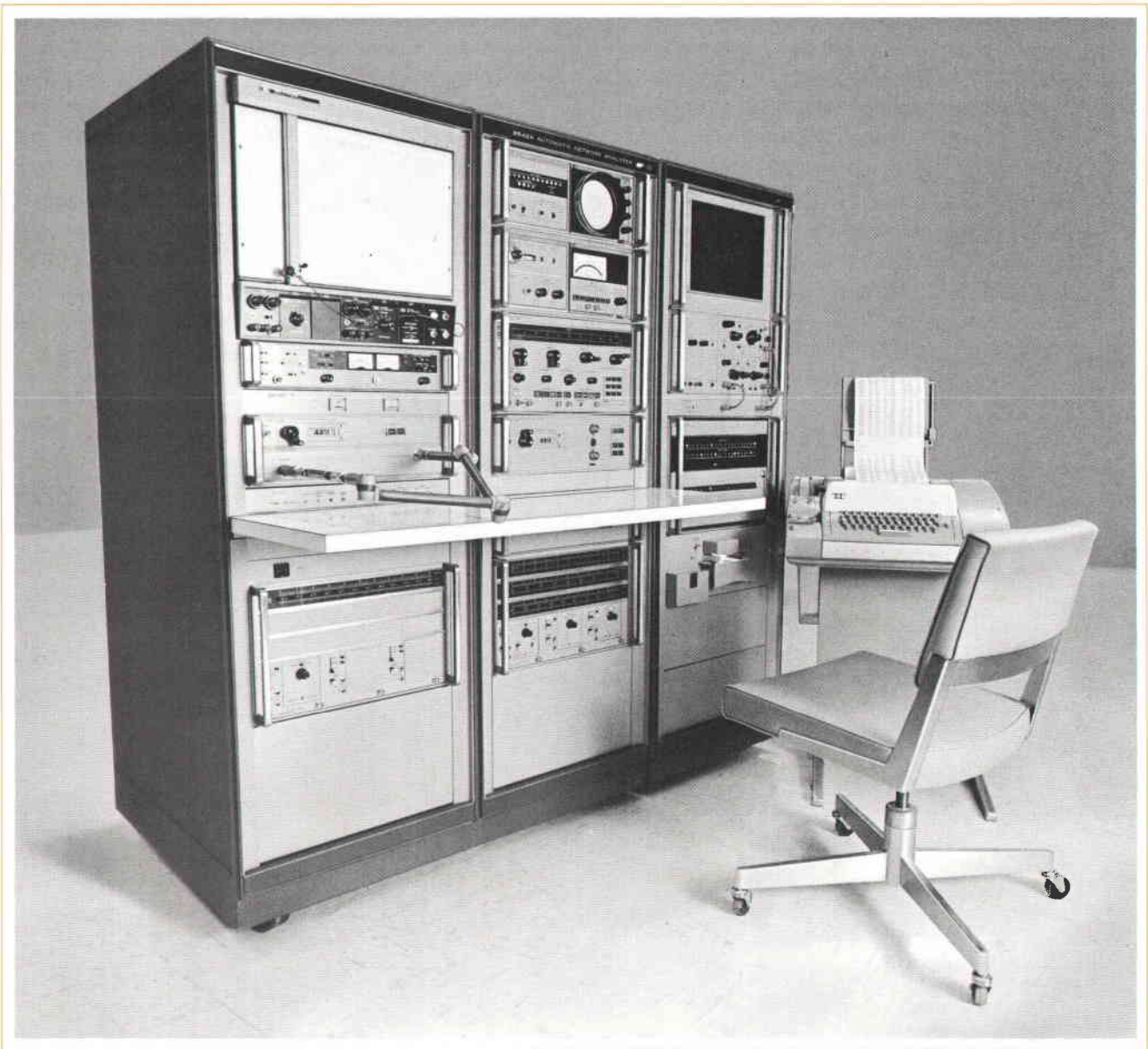

Fig. 1. The automatic network analyzer system in this photo has an unusual number of readouts—note X-Y recorder, oscilloscope displays, and teleprinter. The number of possible configurations is almost unlimited.

valid, accurate microwave instrumentation with good repeatability is required. Inaccuracies in the system are then minimized by the error correction technique given earlier. The residual system errors, all of second-order importance, then are only those caused by imperfect repeatability of connectors and switches, noise in the system, system drift, and errors in the standards used for calibration.

It is important to measure *both* magnitude and phase to achieve accuracy in characterizing networks at microwave frequencies. Even when the intent is only to measure magnitude, phase information is required for high accuracy. For example, when measuring the transmission of a filter, trying to correct for mismatch errors without knowing the phase of the mismatch terms can cause a large ambiguity in the amplitude measurement, no matter how accurate the amplitude detecting device.

3. Speed

The computer can easily control all the instrument functions normally operated by the user. Then, too, the calculating power of the computer greatly shortens the time required for complete network characterization.

4. Flexibility

S-parameters are the parameters most easily measured at microwave frequencies. However, they may not be the desired output from the system. S-parameters comprise a total characterization of the network. Therefore, the computer can transform from the s-parameter set to any other consistent parameter set one may wish. Not only can h, y, or z parameters be determined, but also group delays, VSWR, return loss, or substantially any other desired format. Transformations into other domains are also feasible, such as determining time domain response from frequency domain data. After accurately determining just one set of parameters, the system, with its software, opens an enormous range of measurement capabilities. Flexibility expands further when the Automatic Network Analyzer is augmented with computer-aided design programs. Once a device is characterized by the system, the resulting data can then be used by a computer to synthesize optimum networks for the device.⁴

It is also important that the instrumentation and software structure of the Automatic Network Analyzer be *modular*, so the system can easily be expanded without altering its original configuration or operation. This simplifies adding computer peripherals or instrumentation options.

5. Ease of use

Since the computer controls the instruments, makes the measurements, and manipulates the data, the user is relieved of the mundane and difficult parts of the measurement procedure. The imagination of the R&D or production engineer is not merely supplemented; it is indeed amplified by the system, and furthermore his ideas, now in software, are made usable by many people. More time becomes available and more desire is created to do the long and difficult measurements needed for imaginative design. It is important that interactive hardware and software interfaces be provided between the system and the user. This requires appropriate programming language and a good programming structure. Then, too, the user/hardware interfaces must be simple and effective.

Basic System

The HP Model 8542A Automatic Network Analyzer concept is shown in Fig. 2. The system has three main sections, source, measurement, and computer.

The signal generator provides the RF power from 0.1 to 18 GHz required to test the unknown device. The frequency is computer-controlled and can be stabilized (phase-locked) with at least 650,000 stable, repeatable frequency points across an octave band. An automatic leveling control circuit provides level power and a good source match.

RF from the signal generator is applied to the device under test via the s-parameter test set.⁵ With S_1 and S_2 set as shown in the diagram, the ratio of the test to reference channels is proportional to s_{11} of the device being tested. If S_1 and S_2 are both switched, we measure s_{22} of the device. If S_1 or S_2 are switched separately, we measure s_{12} or s_{21} of the device, respectively.

The "complex ratio detector" measures the *complex* ratio, i.e. the amplitude ratio and phase difference between the reference and test channels.⁶ This information is digitized and routed to the computer via the instrument interface.

The computer takes the s-parameter data and stores it as either calibration data, if measuring standards, or raw, uncorrected data if measuring a device. Output from the computer can be routed to the display, or to other computer peripherals.

There are two basic systems, phase-locked and non-phase-locked, and two possible modes of operation in each, manual or automatic. In the manual mode, the system operates as a group of standard instruments without computer control.

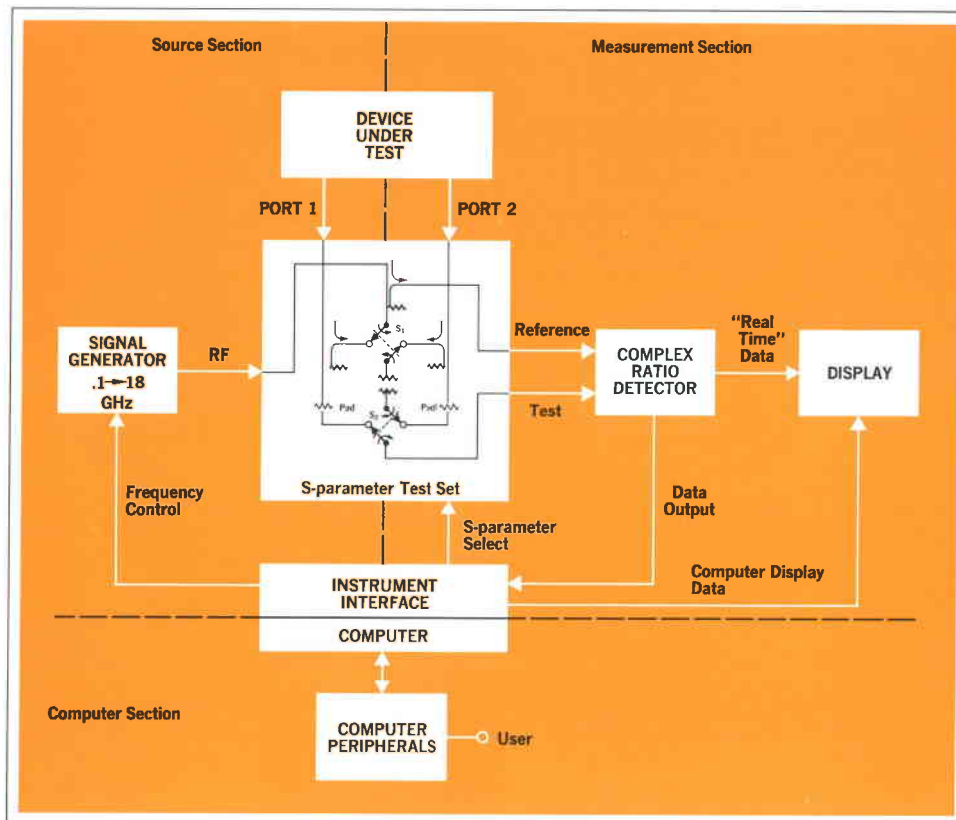

Fig. 2. Functional diagram shows interrelations among the elements of Automatic Network Analyzer system.

Operation

When discussing the operation of the system, we will consider only the phase-locked version operating in the automatic mode. A block diagram of the source and measurement sections of the system is shown in Fig. 3.

The total measurement sequence can be broken down into two steps. The first is to prepare the system to make a measurement. The second is to measure and digitize the high-frequency s-parameter data for storage in the computer.

Typically, this is the preparation sequence:

1. The desired s-parameter is selected in the s-parameter test set.
2. The multiplexed signal source is phase-locked to the reference oscillator via the high-frequency phase lock circuitry.
3. When the system is phase-locked, a phase-lock status indication is sent through the instrument interface to the computer. The system will not take a measurement until phase-lock has occurred.
4. The magnitude of the test signal into the detector is adjusted so as to be within an optimal 5 dB range, to enhance measurement accuracy.
5. DC offset and drift in the system are measured for later correction by the computer.

Now that the system is prepared, the high-frequency s-parameter data are converted into an equivalent digital form:

1. The s-parameter test set puts out reference and test signals proportional to the desired s-parameter.
2. The reference and test channel signals are translated to a fixed IF of 20.278 MHz by the harmonic frequency converter.⁷ Amplitude and phase information are not altered in this down conversion.
3. The automatic gain control in the IF strip normalizes the test channel amplifier to the reference channel amplifier. The reference and test channels are then further down-converted to 278 kHz for optimum detection.
4. The synchronous detector decomposes the real and imaginary components of the test channel signal into an equivalent dc form.
5. This dc voltage is digitized by the A/D converter.

Fig. 3 shows the source section and measurement section overlapping. Actually, the same circuitry is used for both functions. The s-parameter test set and frequency converter used by the measurement section are also used by the source section for phase-locking. This eliminates using a separate phase-lock loop to establish the 20.278 MHz IF in the measurement section, and actually improves system performance.

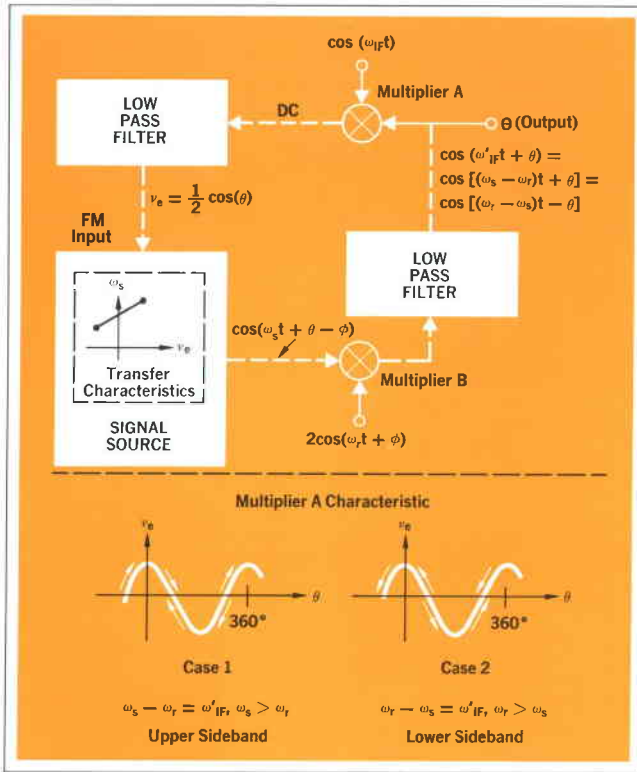

Fig. 4. Simplified diagram of phase lock loop and multiplier characteristics, showing operational scheme.

source frequency f_s . Because frequency errors in coarse tuning may be large, perhaps 40 MHz, a search generator is added to the phase lock loop, which increases its frequency locking range. The search generator systematically changes f_s symmetrically about the coarse tuned frequency. When f_s passes a possible lock point, phase lock occurs and the search generator is turned off. To prevent the phase lock loop from locking on the wrong harmonic (harmonic skipping), the search generator should search less than $\pm f_r/2$ about the coarse tuning frequency, and the coarse tuning must be closer than $\pm f_r/2$. These constraints are most important at the lowest reference frequency used. If harmonic skipping occurs, the source frequency f_s is offset an amount f_r , typically 120 MHz. The symmetrical clipping network and 0.2% coarse tuning accuracy eliminate the possibility of harmonic skipping.

The IF frequency, f_{IF} , could be eliminated and the signal source can still be stabilized. This would also eliminate the sideband sensing circuitry. This is not done because s-parameter information is translated to an intermediate frequency, and some means of IF stabilization must also be provided. Two phase lock loops could be used, but one will work more simply. If the reference channel IF strip is connected to the filtered output of multiplier B, the signal source and reference channel IF

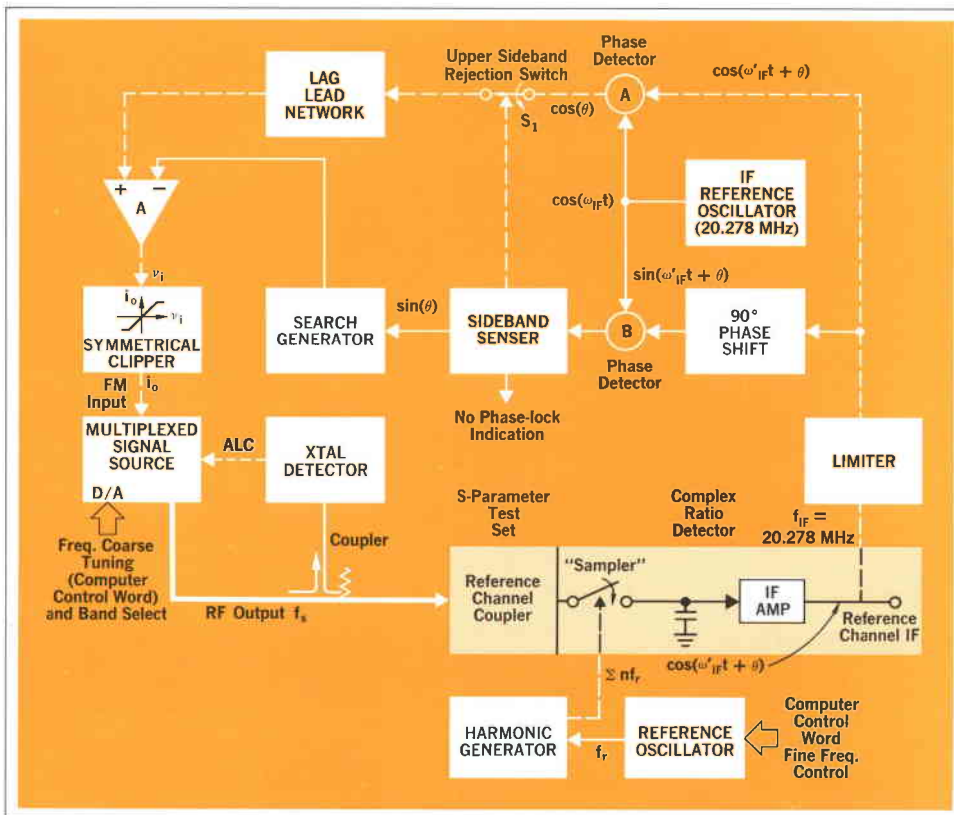

Fig. 5. Detailed block diagram of high-frequency phase lock loop.

About the hardware . . .

Each article in this issue of the Hewlett-Packard Journal deals with some aspect of automatic network analysis. The HP Model 8542A Automatic Network Analyzer is not a single product of fixed characteristics, but is instead a modular option system. Each system produced is tailored to its use by incorporating appropriate choices among options. There are choices of signal sources, test sets, detectors, computers, and computer peripherals.

The specific system described throughout this issue incorporates two important options for highest accuracy, a frequency-stabilized signal source, and a new precision detector. The accuracy curves given by Hand are typical of systems operating between 2.0 and 12.4 GHz with the options, but of course are not typical of others. The new precision detector will be available to update earlier HP automatic analyzers of the 8542A family.

Many Hewlett-Packard divisions contributed directly to the system's development. Some instruments could be directly placed in the system with no modifications. Others, which were not originally designed with digital interfaces, were updated. The source and measurement instruments were modified to accept the broadband phase-locking capability. The performance characteristics of other instruments were improved to meet the accuracy requirements of the system. A number of new instruments were designed especially for the Automatic Network Analyzer.

are simultaneously stabilized in frequency. The reference channel IF voltage is maintained relatively constant by the ALC feedback loop in the signal source. This provides a low-noise, high-level feedback point to connect the high-frequency phase-lock loop.

Reference Oscillator and System Noise Considerations

The reference oscillator provides the stable reference frequency (f_r) required by the high frequency phase-lock loop. The frequency range for f_r is from 60 to 140 MHz in 100-Hz steps, synthesized from a crystal standard.⁸ The synthesis process is controlled by a fine-frequency control word from the computer. To achieve the high spectral purity requirement of the system, the broadband AM and PM noise out of the synthesizer is reduced by using an oscillator phase-locked to the output frequency of the synthesizer. This phase-lock loop really comprises a tracking filter. The box on page 9 explains how the phase-lock loop can perform in this way.

The tracking filter cannot respond to a phase noise input which lies outside the phase-lock loop bandwidth, as demonstrated mathematically in the box. It can also be seen that there is no steady-state frequency error caused by the tracking filter. A *bandpass* filter is thus formed, which is centered about the reference frequency (f_r), and which tracks the reference frequency over the 60 to 140 MHz range.

There are two other sources of noise which contribute to the output power spectrum of the reference oscillator besides the noise from the synthesizer. One is the noise

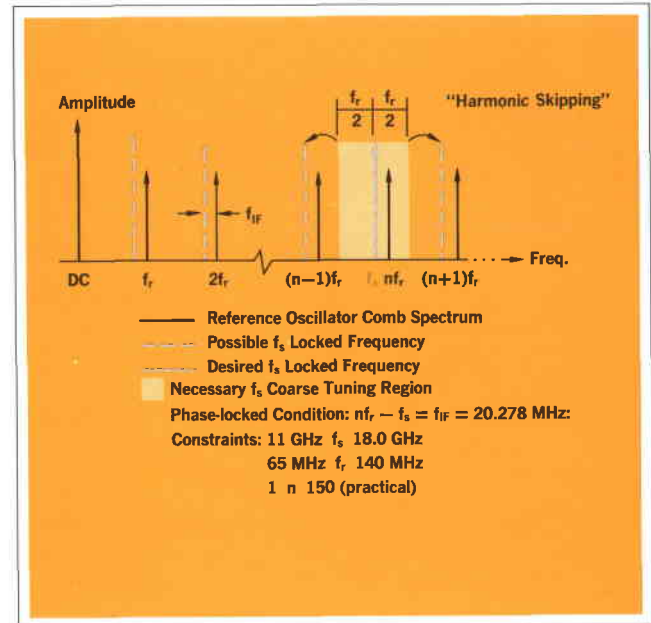

Fig. 6. Source phase-locks when $nf_r - f_s = f_{if}$.

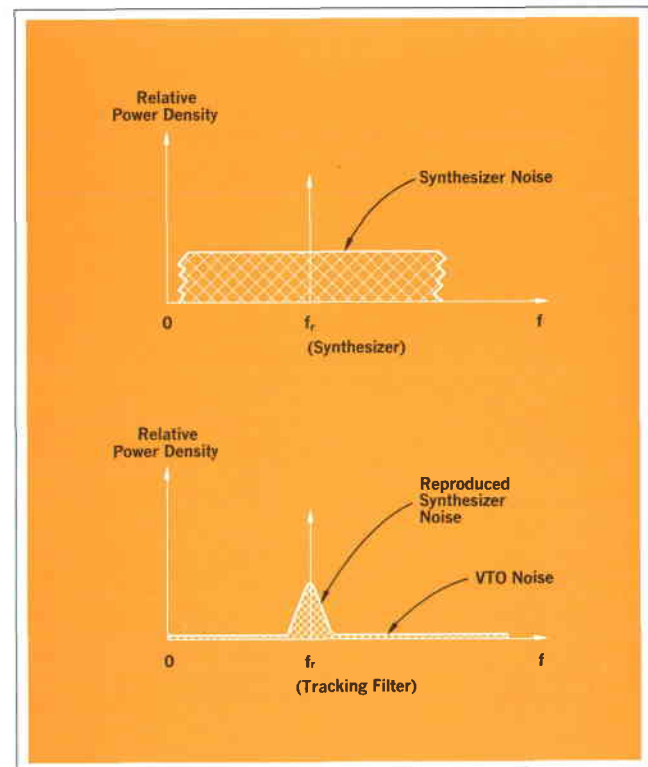
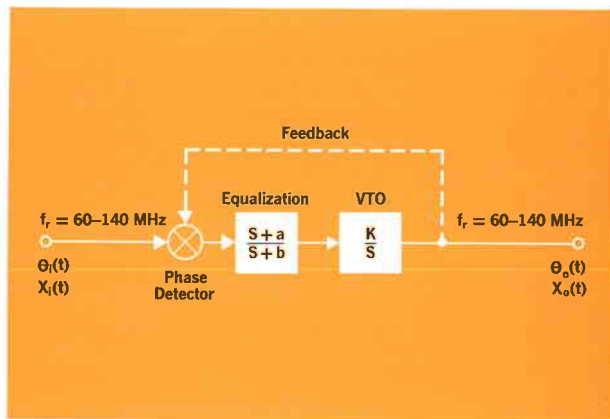

Fig. 7. Power spectral densities.

from the phase detector and dc amplifier in the phase-lock loop of the tracking filter. Careful low-noise design minimizes this source of noise. The other source of noise is the phase noise of the VTO. Let us see how this noise is reduced.

The loop is a *high-pass* filter to the phase noise produced by the VTO. Therefore, the VTO noise within the loop bandwidth will be reduced by the high-pass filter, but noise outside the loop bandwidth will pass. A high-quality varactor-tuned VTO was therefore designed to minimize the phase noise outside the loop bandwidth.

The accompanying figure will help to understand how the phase-lock loop performs as a tracking filter. A phase-lock loop acts as a filter to both amplitude and phase sidebands around a carrier. To see how this interesting function is achieved, consider the block diagram here.



The signal input to the filter is

$$X_i(t) = A_c \cos [2\pi f_r t + \phi_i(t)],$$

where $\phi_i(t)$ is any input phase function with zero mean which has the spectrum $\Phi_i(f)$.

Let $\theta_i(t) \triangleq 2\pi f_r t + \phi_i(t)$.

The two terms on the right hand side are not correlated. The tracking filter responds only to the total argument $\theta_i(t)$, and hence to the phase modulation, but it will not respond to the amplitude modulation. There is a small amount of AM-to-PM conversion, but it may be regarded as negligible.

The transfer function for the tracking filter in the diagram is

$$\frac{\Theta_o(S)}{\Theta_i(S)} \triangleq H(S) = \frac{k(S+a)}{S^2 + (k+b)S + ka}, \quad (1)$$

which is a low-pass filter function. It follows that

$$\theta_o(t) = 2\pi f_r t + \phi_\epsilon(t) + \phi_i(t) * h(t),$$

where

$h(t)$ = the inverse Laplace transform of $[H(S)]$

$\phi_\epsilon(t)$ = transient and steady state phase error between the input and output of the filter and

We thus have a typical engineering tradeoff. The noise of the synthesizer is reduced by decreasing the loop bandwidth, but decreasing the loop bandwidth increases the noise contribution of the VTO. An optimum bandwidth exists which will minimize the sum of the two noise sources. There also is a requirement for minimum lock-up time, which is a function of the loop bandwidth. In the light of these factors, it was possible to pick a best compromise for loop bandwidth. The synthesizer output spectrum and the resulting spectrum, after passing through the tracking filter, are shown in Fig. 7.

$$\phi_i(t) * h(t) = \text{convolution of } \phi_i(t) \text{ with } h(t).$$

The output signal $x_o(t)$ will be

$$x_o(t) = B_c \cos [2\pi f_r t + \phi_\epsilon(t) + \phi_i(t) * h(t)],$$

where B_c is an arbitrary constant.

Using the Fourier transform and assuming

$\phi_i(t) * h(t)$ is small, the two-sided *steady-state spectrum* is

$$X_o(f) = \frac{B_c}{2} \left\{ [\delta(f - f_r) e^{i\phi_\epsilon} + \delta(f + f_r) e^{-i\phi_\epsilon}] + j[\Phi_i(f - f_r)H(f - f_r) - \Phi_i(f + f_r)H(f + f_r)] \right\}, \quad (2)$$

where

$\Phi_i(f - f_r)H(f - f_r)$ = filtered output translated to f_r ,

ϕ_ϵ = steady state phase error, and

$\delta(f - f_r)$ = sinusoidal component at f_r .

The one-sided power spectrum of $X_o(f)$ follows from Eq. 2 and is shown below.

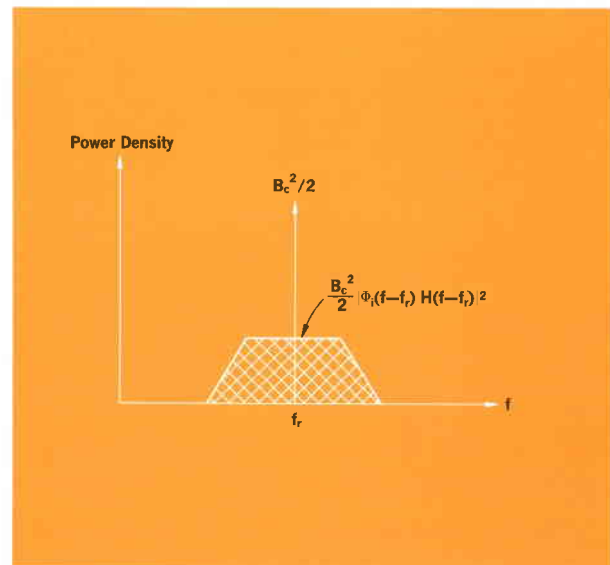

In summary, Eq. 1 gives the loop transfer function, and Eq. 2 is the resultant steady-state spectrum. This approximates the typical response seen on a spectrum analyzer.⁹

This discussion applies to the high-frequency phase-lock loop as well as to the tracking filter.

One more question remains, regarding the total phase noise measured by the computer. There are three main sources of this noise: (1) The reference oscillator noise multiplied by the harmonic number n , (2) multiplexed signal source noise, (3) noise produced by components in the high-frequency phase-lock loop, primarily the samplers. The noise from (1) and (2) is reduced by the high-pass filter characteristic of the high frequency phase-lock loop, but the equivalent noise created by the sampling process is not reduced. All three noises are then reduced by a 10-kHz low-pass filter in the detector, by the integrating A/D converter, and by computer time averaging. The resultant noise figure of the system is mainly determined by the noise figure of the samplers.

Future

Future automatic systems may become measurement terminals, much like those of the computational time-sharing services now available. In this type of system, digital data and high level commands are transferred between the measurement terminal and the central processor, linking the user with the power of a large central computer. ■

References

- [1]. Richard A. Hackborn, 'An Automatic Network Analyzer System,' *microwave journal*, Vol. 11, No. 5, May 1968.
- [2]. Kay B. Magleby, 'A Computer for Instrumentation Systems,' **Hewlett-Packard Journal**, March 1967.
- [3]. Richard W. Anderson, 'S-Parameter Techniques for Faster, More Accurate Network Design,' **Hewlett-Packard Journal**, Feb. 1967.
- [4]. Les Besser, 'Combine S-Parameters with Time Sharing and Bring Thin-film, High-frequency Design Closer to a Science than an Art,' *Electronic Design*, Aug. 1, 1968.
- [5]. Stephen F. Adam, George R. Kirkpatrick, and Richard A. Lyon, 'Broadband Passive Components for Microwave Network Analysis,' **Hewlett-Packard Journal**, Jan. 1969.
- [6]. Richard W. Anderson and Orthell T. Dennison, 'An Advanced New Network Analyzer for Sweep-Measuring Amplitude and Phase from 0.1 to 12.4 GHz,' **Hewlett-Packard Journal**, Feb. 1967.
- [7]. Wayne M. Grove, 'A DC to 12.4 GHz Feedthrough Sampler for Oscilloscopes and Other RF Systems,' **Hewlett-Packard Journal**, Oct. 1966.
- [8]. Alexander Tykulsky, 'Digital Frequency Synthesizer Covering 0.1 MHz to 500 MHz in 0.1 Hz Steps,' and 'Phase Noise in Frequency Synthesizers,' **Hewlett-Packard Journal**, Oct. 1967.
- [9]. A. Bruce Carlson, 'Communication Systems: An Introduction to Signals and Noise in Electrical Communication,' McGraw-Hill, 1968.



Douglas Kent Rytting

Doug Rytting came to the HP Microwave Division in Palo Alto directly from Utah State in 1966. He began quickly to contribute to the Division's engineering effort, with work on broadband detection schemes, improved probes for the Vector Voltmeter, and system interfacing for early Automatic Network Analyzers. Recently he became Project Supervisor for the company's ANA developments. Doug and his wife, Sharon, have a

two-year-old girl. Doug is in charge of a Cub Scout program in Cupertino, and is pursuing an MS at Stanford under the HP Honors Program. He's a member of Phi Kappa Phi and is on one of the national technical committees of the IEEE microwave group.



Steven Neil Sanders

With a BSEE from Utah State in 1967, Steve Sanders came straight to HP. He has been steadily associated with microwave automatic network analyzer systems ever since, doing new work on the high-frequency aspects of phase-locked loop circuits, among other system contributions. He is now Project Engineer for ANA systems. Steve is about to receive his Master's from Stanford under the HP Honors Program, and

plans to continue toward a higher degree. He is a member of Phi Kappa Phi. Although they are new parents, Steve and his wife, Annette, are not giving up their shared outdoor activities — skiing, ice skating, and hiking.

Software for the Automatic Network Analyzer

By William A. Ray and Warren W. Williams

SUCCESS IN DESIGNING COMPUTER-OPERATED SYSTEMS depends as much on software—the set of detailed program instructions—as upon hardware. The software package is often designed and written to solve only one special problem. However, in keeping with the overall objectives of the HP automatic network analyzer systems, software objectives had to take on an unusual degree of generality:

- 1) Make the collection of instruments act like one very powerful instrument.
- 2) Give the engineer the ability to expand software flexibility in graduated steps.
- 3) Make it easy to add instrumentation or computing power to existing systems.

These objectives led to designing a library of building blocks or program routines, each performing some specialized function, these blocks combining together efficiently to perform complete measurements.

Standard Measurement Software

An 8542A is installed initially with a set of general purpose programs ready to make most linear network analysis tests. Table I lists such a package for a 2-port test set.

A series always begins with system calibration. The program asks the user to connect a series of known devices, such as short circuits or through connections, at the system's test ports. The program then measures these devices, storing the differences between their apparent and ideal parameters. The reflection from a short, for instance, is affected by source match and coupler tracking. After measuring the magnitude and phase of the apparent reflection, the computer can calculate these

error terms. Later, measurements can be corrected automatically for these effects, so the user can concentrate on *his* device instead of on the microwave measurement problems.

Once the system has been calibrated, the other programs in Table I can be loaded to make specific tests. These all have access to the calibration data in a reserved section of the computer memory.

Fig. 1 shows the teletype print-out and plot from a typical session. The system has been calibrated and is now ready to perform as a transistor test set. It is only necessary to load the transistor test program. The system signifies it is ready by typing 'CONN DEVICE'. Once the user has inserted the transistor, he types in some logging information for his own use (underlined) and presses carriage return. The system then automatically measures, corrects and saves the s-parameter description of the transistor. This fundamental system measurement is forward and reverse reflection and transmission with 50 ohm loads and sources. The description is a complete one in the sense that the other 2-port parameters— h , y , and z —can be derived from it¹. The listings and plot in Fig. 1 were all derived from the same measurement, requested just by selecting a task number from a table. The entire sequence, including calibration and type-out, required only a few minutes.

Thus the system acts like an instrument. The user connects his unknown device, then specifies actions through the teletype keyboard and a switch panel. He need not be concerned about the array of knobs and dials before him; the computer controls all their settings. By using a programmed test sequence, the computer system becomes easier to run than a manual set up.

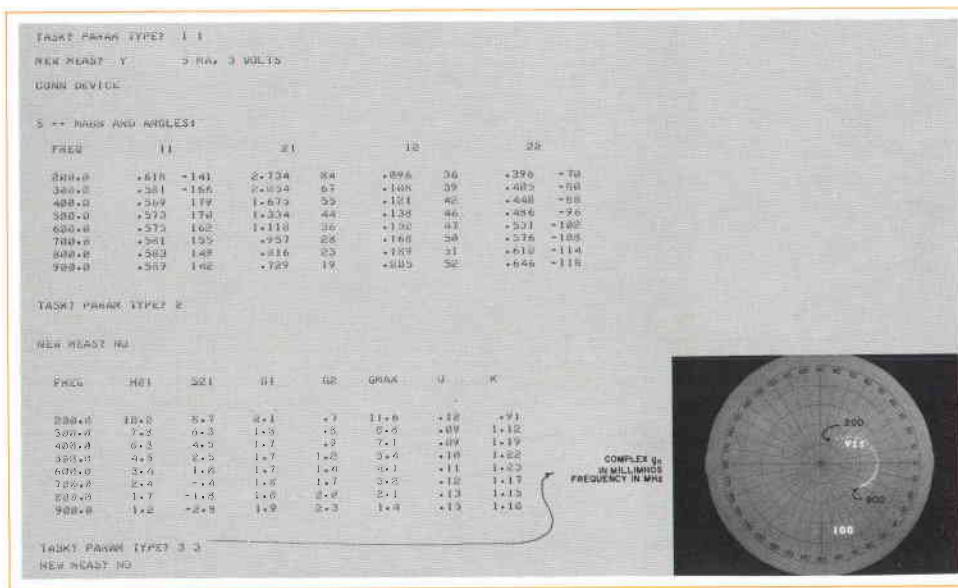

Fig. 1. Typical session run with standard software by the Automatic Network Analyzer. After taking a full set of s-parameter measurements the instrument has then calculated various gain parameters in dB. U is a unilateral gain factor; K is a criterion of stability. Y₁₁ is one of a number of complex parameters which can be calculated and displayed at will.

BASIC Interpreter

Eventually, the user will desire some special test not available in the standard programs supplied. Often this is simply a different way of displaying the fundamental s-parameter data, so he can take advantage of the standard 8542A calibration/corrected measurement routines. For many such purposes, he can use an interactive language, BASIC².

BASIC is a simplified subset of such full programming languages as ALGOL or FORTRAN. BASIC is algebraic and easy for technical people to learn, requiring only a few hours even on one's first exposure to computer programming. As each line of program is typed in, it is immediately checked for errors: misspelling, missing punctuation, etc. This is an ideal teaching method because incorrect responses are caught and corrected right away. Other types of errors which involve the logic of the program rather than its syntax only become apparent when it is run. Again, BASIC has an advantage because it is an interpreter, that is, it runs the program from BASIC statements instead of converting to machine language. So one can run the program and immediately go back to an editing mode to fix any errors.

In the 8542A, BASIC is normally used for special outputs. A standard calibration tape is used and the data transferred to a reserved area. The user then reads in BASIC plus an s-parameter measurement program supplied, finally typing in his special display coding.

Fig. 2 shows such a sequence for a reflection test, plotting return loss on the rectangular CRT. Note how the program can be run, errors fixed and then run again. Once BASIC was loaded, no additional paper tapes were

required.

Statements are identified by the line numbers on the left. Lines beyond 9000 were a standardized reflection measurement routine. The only programming required was lines 100 through 240 which called the measurement routine (GOSUB 9000) and then displayed the plot (line 210).

FORTRAN

In any computer there will come a time when the memory capacity is exceeded. At this point one must trade some convenience or capability for more program space. For the automatic network analyzer, this means trading the convenient interactive programming features of BASIC for a compiler language like FORTRAN. The compiler checks for syntax errors and translates to machine-language instructions once, as a separate operation from running the program. Thus one does not have to keep editing and interpreting intelligence in the computer when making measurements; the space is available for a more elaborate measurement program. The compiled program runs faster than an interpreter program because the translation has been done previously.

Note that although one gives up editing interaction while writing the program, the resulting programs can still interact with the user. The standard measurement programs are all written in FORTRAN; they interact through switches and teletype as shown in Fig. 1.

The transition from BASIC to FORTRAN is straightforward because the two languages are similar in many ways, simply using different words to say the same thing. Fig. 3 shows a FORTRAN listing which performs the

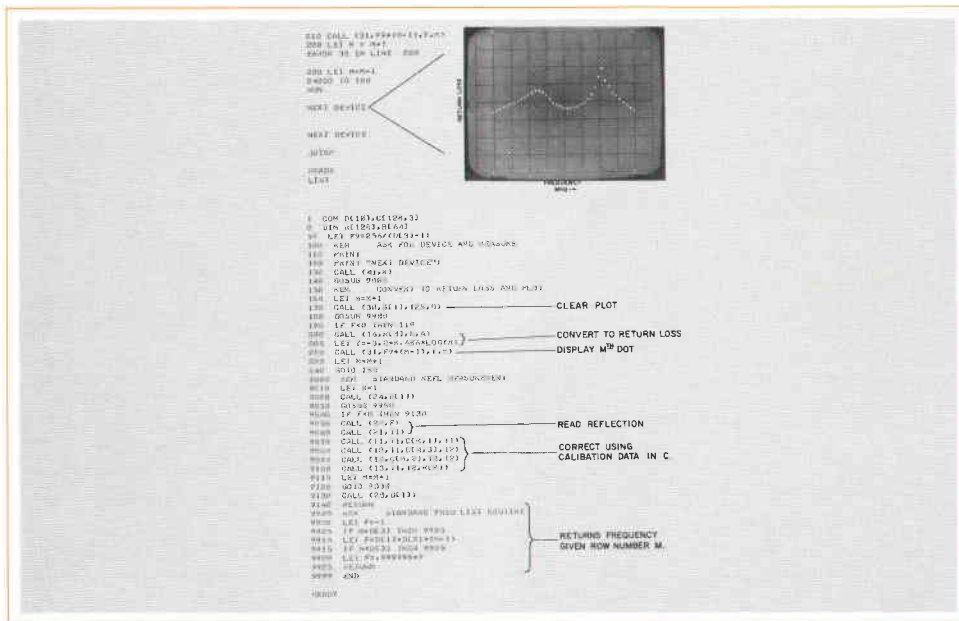

Fig. 2. Sequence for a reflection test, run with standard BASIC language package. Program plots return loss, a function not included in standard system programming. The only programming necessary for this special function was that shown in lines 100-240.

same function as the BASIC program in Fig. 2. Unlike BASIC, it required a half-hour's work to convert the FORTRAN language program to a machine language program, a process which must be repeated each time a change is made in the program. Besides allowing for bigger programs, FORTRAN has two advantages over BASIC. Variable names are easier to read (CALIB instead of C for the calibration data array) and true subroutines are available (call CORR1 instead of GOSUB 9000).

The availability of true subroutines is very important because it makes modular software possible. In the BASIC program, the code between 9000 and 9140 was executed by a GOSUB from another part of the program. This is the same function as call CORR1 in the FORTRAN program. In both cases the main program can transfer to the routine from any number of places, and have it return automatically when done. The difference is that the BASIC corrected measurement routine shared the same variables as the rest of the program, while any CORR1 variables are totally isolated from any other routine. This is not very important with simple programs because one can keep all the names straight. However, programs may grow until they become too complicated to treat as one entity. Now true subroutines are needed to isolate functional modules so they can be written and verified — 'debugged' — once, then added to one's personal library. In the program shown, the user need only know how to call for the corrected measurement; he cannot affect its reliability by using one of its variable names or accidentally changing a statement.

This capability has been used in the 8542A software to build a modular hierarchical package, so constructed that an engineer need only re-write a portion to meet his special needs. Figure 4 shows the subroutine hierarchy for the example program in Figure 3. The main measurement program RPL0T has access to this package through the high level commands noted on the arrows which are the names called in RPL0T (see Fig. 3). Each of these routines calls in turn another layer of more specialized routines down to those which communicate with the instruments. Most, such as the instrument supervisor, are common to all the 8542A software.

The entire library that is needed to write the standard software is available for others writing new test programs. Of course the engineer is not restricted to writing main programs; as his needs and capabilities increase he can call, modify or replace any portion of the package. For example, he may want to change the test frequency rule from linear steps to logarithmic spacing, or perhaps to a table of critical frequencies. Since this information has been concentrated in one short routine (CALF3), he need replace only it, rather than re-writing the many routines which call it up. This is what is meant by *functional* software modularity.

Growth Capabilities

The software has been designed to grow, either by adding additional instruments (bias supplies, X-Y recorders, etc.) or adding computing power. The standard 8542A system uses a computer of 8000-word memory. This memory can be expanded with 4000-word internal core

```

PAGE 01
0001 PROGRAM RPL0T
0002 DIMENSION RHO(128), IBUF(128)
0003 COMMON B(10), CALIB(3,128)
0004 C
0005 C INITIALIZE BAILOUT AND FREQ SCALE
0006 C
0007 CALL BAIL1
0008 CALL CALF3 (2,1,F1)
0009 CALL CALF3 (4,M,F2)
0010 FSC1 = 250.0 / (F2-F1)
0011 C
0012 L PRINT INSTRUCTION AND WAIT FOR OPERATOR ANSWER
0013 C
0014 I0 WRITE (2,1)
0015 1 FORMAT (// "NEXT DEVICE =" )
0016 READ (1,*) DMY
0017 C
0018 C MEASURE DEVICE
0019 C
0020 CALL CORR1 (RHO,1,128,1,1)
0021 C
0022 C CONVERT TO RETURN LOSS AND PLOT
0023 C
0024 M = 1
0025 CALL SETP1 (IBUF,128)
0026 100 CALL CALF3 (2,M,F)
0027 IF (F) 10,110
0028 110 CALL CPOL2 (RHO(M),M,A)
0029 IY = -3.2 * 8.686 * ALOG(P)
0030 IX = FSC1 * (F-F1)
0031 CALL PLP1 (IX,IY)
0032 M = M + 1
0033 GO TO 100
0034 END
END OF TAPE

```

Fig. 3. FORTRAN program for same function as Fig. 2. The calls to CORR1 and CALF3 access subroutines in place of the BASIC code between lines 9000 and 9999.

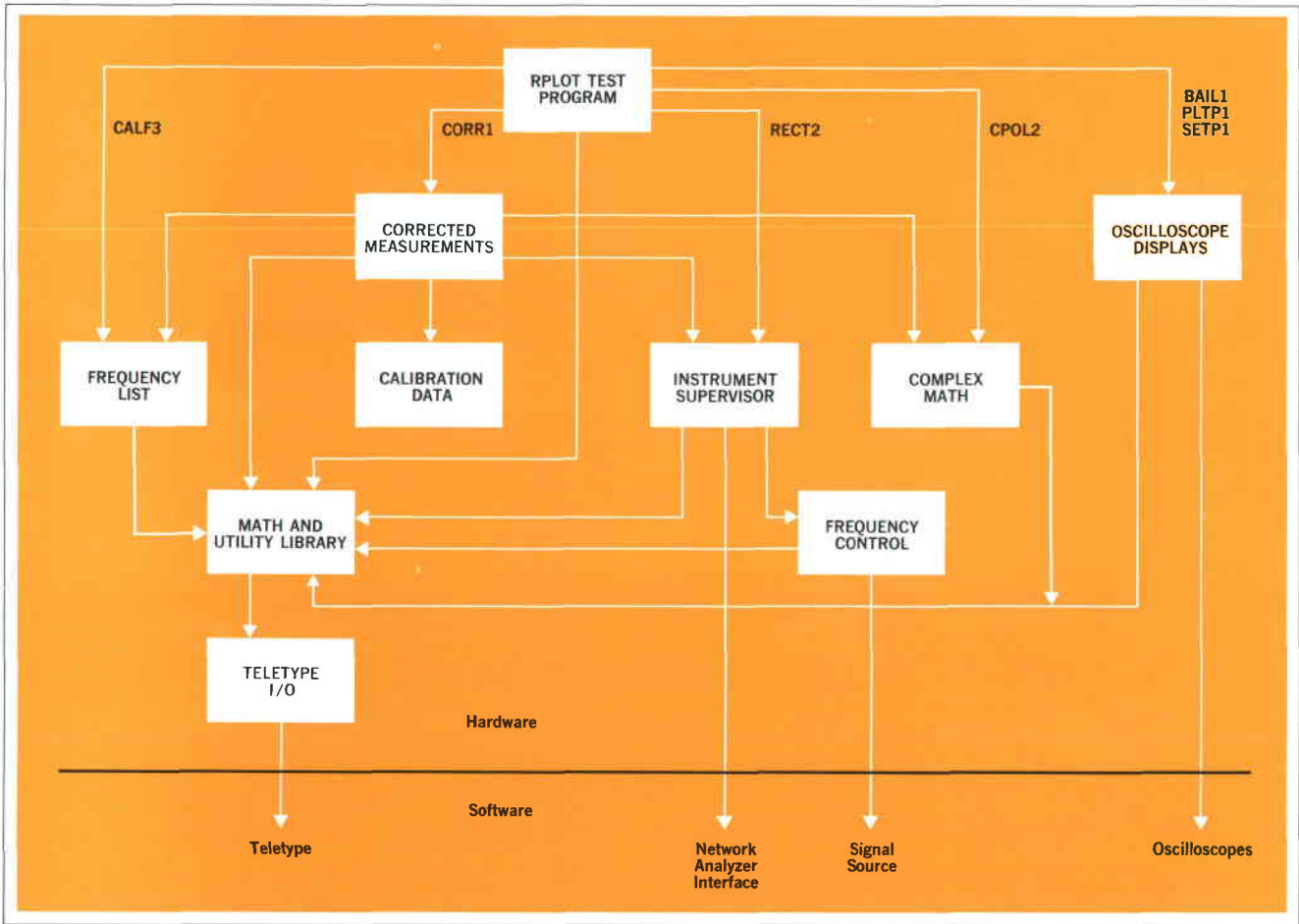

Fig. 4. Hierarchy of routines used by the example FORTRAN program RPL0T of Fig. 3. Here the special test program used only the upper layers, through a few high-level commands. The layered structures, however, can be accessed at any level to suit the application at hand.

memory increments or with hundred-thousand word discs, allowing much more complex programs.

In the FORTRAN discussion above, the trade-off between convenience and memory size was mentioned. With increased memory, this trade-off is altered drastically. In fact, a 16K (16,000-word) computer is roughly 5 times as powerful as an 8K version because both FORTRAN and BASIC require so much of the smaller memory for utility routines. Only 2000 to 3000 words out of 8000 are available for test programs and data, while the large machine has 10,000 words available because it does not add to the overhead. This makes it possible to combine an entire series of standard programs (such as the one in Table I) into a single program, plus doubling the data capacity. Similarly, much more sophisticated BASIC programs can be written.

A disc memory which records data magnetically on a rotating surface adds a different kind of capability. With internal core memory, the computer can access any piece of data within 2 μ sec. With the disc, it may take up to 30 msec to access the first word of a data block. However, the disc economically provides much larger storage—176,000 or more words. The 8542A network analyzer disc system saves a number of FORTRAN and BASIC programs on the disc which can be read into memory in 100 msec instead of the full minute which it takes to read a paper tape. BASIC or FORTRAN programs can call one another, so the user can add BASIC tasks to standard FORTRAN programs. A task in the stand-

ard program can call up a user's BASIC program after leaving the measured data on the disc. The BASIC program can now analyze the data and return to the standard program for the next test. The user is not even conscious of the exchange, since it happens in a fraction of a second. Now the measurements are made with the efficiency of a compiled program, but the analysis program can be written in the convenient interactive mode of BASIC.

Future

Although the 8542A software is a unique package for bringing software flexibility to microwave engineers, it does so within the framework of conventional computer languages and techniques. This experience has uncovered a number of new requirements for further instrumentation software, particularly for improvements in languages and programming systems. Implementing for these needs will soon make it even easier for the engineer to engage the computer's full capabilities.

Acknowledgments

We are grateful for the assistance of Lucienne Jackson in preparing the software, and to Jesse Pipkin and Lyle Jevons for their help in designing and refining the package. 📧

References

- [1] 'S-Parameter Techniques for Faster, More Accurate Network Design,' **Hewlett-Packard Journal**, Feb., 1967.
- [2] Peterson, Gerald L., 'BASIC, The Language of Time-Sharing,' **Hewlett-Packard Journal**, Nov., 1968.

William A. Ray



After taking his Bachelor's in electrical engineering at Stanford in 1963, Bill Ray went to Stanford Research Institute for a couple of years. He did work there on antennas — measurements, analysis and theory — and that led him to acquire knowledge in depth about computer capabilities. At Hewlett-Packard, Bill first did application engineering on automatic network analyzers, then moved to the design labs to head software development

for these new systems. His marriage and subsequent fatherhood caused him to give up racing sports cars and flying airplanes, but he still sails. His craft is a Javelin.

Warren W. Williams



Bill Williams is a native of Texas. His education included five years as an electronic technician in the Navy. Bill did his undergraduate work at Columbia, New York, and at San Francisco State, taking a degree in math at State in 1967. He came directly to HP from State, and has been concerned with automatic network analysis ever since. He is now the systems programmer for the design group. Married to a California girl, Bill is now a

father twice over. He speaks Japanese and hopes one day his HP career will use it.

Developing Accuracy Specifications for Automatic Network Analyzer Systems

By B. P. Hand

IN THE USUAL MEASUREMENT SYSTEM either those few instrument specifications which directly affect accuracy are added linearly, or one predominates and is taken as the system error. In microwave measurement systems, however, the number of sources of error is so much greater that adding them linearly results in too pessimistic an error figure—one which is extremely unlikely to occur. Furthermore, automatic measurement systems remove various frequency-dependent errors which are usually the major ones. As a result, many of the more subtle errors which are usually neglected as having unimportant effect must be considered.

Establishing accuracy specifications for the various 8542A systems, then, has involved examining and including many additional sources of error and developing means to combine them in realistic fashion. A general technique has been evolved which appears to be applicable in principle to any automatic measurement system.

Reviewing The Ideal Case

Before any discussion of the technique and its results, it is in order to review the whole method of operation of the system, insofar as accuracy is concerned—the calibration process, the model set up as a result, the measurement process, and the correction of the measurement data to yield the final results. A general case will be considered, in which both reflection and transmission coefficients are measured. A representative system would involve, for example, completely characterizing a coaxial attenuator in the range from 2 to 12.4 GHz. Other cases, such as measurements below 2 GHz, or of reflection only, differ only in detail.

The test unit includes two directional couplers for sampling the incident signal (Reference) and the reflected or transmitted signal (Test). Externally, it has an 'Unknown' port, to which the device under test is connected,

and a 'Return' port, to which two-port devices are also connected. The model set up in the calibration process includes the properties of this unit, plus some of the errors due to the other instrumentation.

Calibration Process

The calibration process involves making sufficient measurements with standards and conditions of known characteristics to determine all these properties. Fig. 1 is a signal flowgraph of the system model, with the various model coefficients identified.

The *s*-parameters of any device connected to the Unknown or between Unknown and Return ports are represented by s_{11} , s_{21} , s_{12} , s_{22} in the usual notation.

Flowgraph analysis results in the following general expressions for the ideal measured values of reflection (M_R) and transmission (M_T) coefficients:

$$M_R = e_{00} + \frac{s_{11}e_{01}(1 - s_{22}e_{22}) + s_{21}s_{12}e_{22}e_{01}}{1 - s_{11}e_{11} - s_{22}e_{22} - s_{21}s_{12}e_{11}e_{22} + s_{11}e_{11}s_{22}e_{22}}$$

$$M_T = e_{30} + \frac{s_{21}e_{32}}{1 - s_{11}e_{11} - s_{22}e_{22} - s_{21}s_{12}e_{11}e_{22} + s_{11}e_{11}s_{22}e_{22}}$$

Using D_1 for the common denominator:

$$M_R = e_{00} + \frac{s_{11}e_{01}(1 - s_{22}e_{22}) + s_{21}s_{12}e_{22}e_{01}}{D_1}$$

$$M_T = e_{30} + \frac{s_{21}e_{32}}{D_1}$$

The calibration measurements are as follows:

1. Reflection with a sliding load. The computer measures the reflection as connected, and then, three times, directs the operator to slide the load and makes another measurement. It then constructs a circle through these four values and finds the center of the circle, so that, effectively, $s_{11} = 0$, s_{21} , s_{12} and s_{22} are also zero, of course, so

$$M_1 = e_{00}$$

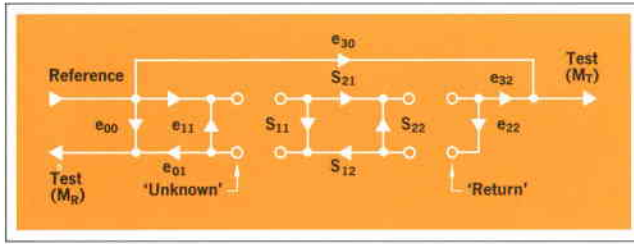

Fig. 1. Signal flowpath of system model.

- Transmission without a through connection (both measurement ports terminated).

$$s_{11} = s_{21} = s_{12} = s_{22} = 0,$$

so $M_2 = e_{30}$

- Reflection with a direct short.

$$s_{11} = -1; s_{21} = s_{12} = s_{22} = 0,$$

so $M_3 = e_{00} - \frac{e_{01}}{1 + e_{11}}$

- Reflection with an 'Offset Short' (a shorted coax line one-quarter wavelength long at midband).

$s_{11} = -e^{-j2\beta l}$, where l is the length of the short. For convenience, let $-e^{-j2\beta l} = \Gamma S$. $s_{21} = s_{12} = s_{22} = 0$,

so $M_4 = e_{00} + \frac{\Gamma S e_{01}}{1 - \Gamma S e_{11}}$

- Reflection with a through connection.

$$s_{11} = s_{22} = 0, s_{21} = s_{12} = 1,$$

so $M_5 = e_{00} + \frac{e_{22}e_{01}}{1 - e_{11}e_{22}}$

- Transmission with a through connection.

$$s_{11} = s_{22} = 0, s_{21} = s_{12} = 1,$$

so $M_6 = e_{30} + \frac{e_{32}}{1 - e_{11}e_{22}}$

These six equations are solved by the computer to give the desired model parameters:

$$e_{00} = M_1$$

$$e_{11} = \frac{\Gamma S(M_1 - M_3) + (M_1 - M_4)}{\Gamma S(M_3 - M_4)}$$

$$e_{01} = \frac{(1 + \Gamma S)(M_1 - M_3)(M_1 - M_4)}{\Gamma S(M_3 - M_4)}$$

$$e_{30} = M_2$$

$$e_{22} = \frac{M_5 - M_1}{e_{01} + (M_5 - M_1)e_{11}}$$

$$e_{32} = (M_6 - M_2)(1 - e_{11}e_{22})$$

At the end of the calibration process, these six values are stored for use in correcting all subsequent measurements.

Measurement Process

On an unknown, reflection and transmission measurements are made, then either the device is reversed between ports, or internal switching reverses the direction of signal flow, depending on which test unit is used, and the two measurements are made again. The flowgraph analysis is essentially the same in either case. The measurements result in four ideal values as follows:

$$M_{R1} = e_{00} + \frac{s_{11}e_{01}(1 - s_{22}e_{22}) + s_{21}s_{12}e_{22}e_{01}}{D_1}$$

$$M_{T1} = e_{30} + \frac{s_{21}e_{32}}{D_1}$$

$$M_{T2} = e_{30} + \frac{s_{12}e_{32}}{D_2}$$

$$M_{R2} = e_{00} + \frac{s_{22}e_{01}(1 - s_{11}e_{22}) + s_{12}s_{21}e_{22}e_{01}}{D_2}$$

where D_2 is D_1 with the s-parameters interchanged:

$$D_2 = 1 - s_{22}e_{11} - s_{11}e_{22} - s_{12}s_{21}e_{11}e_{22} + s_{22}e_{11}s_{11}e_{22}$$

This corresponds to reversing the device.

Correction Process

The computer then solves the equations above for s_{11} , s_{21} , s_{12} , and s_{22} . No explicit solution is given here, since it would be very complex. The computer uses an iterative process which has been demonstrated to have negligible error.

Sources of Error

The above process takes into account only some of the possible sources of error. There are a great many others, but these may be conveniently grouped into three types:

- 1) Imperfections of the three calibration standards. These are carefully manufactured to very close tolerances, but the tolerances do exist and must be taken into account. Besides diameter and length variations, other factors considered are plating, skin depth, eccentricity, surface roughness, and air dielectric.

- 2) Noise. This, of course, enters into every measurement. Its effect is reduced by averaging multiple measurements — at least two at high signal levels and up to twelve at lower levels.

- 3) 'Gain Error'. This is a catch-all term to include all other sources of error, mainly in the instrumentation, which directly affect the magnitude and phase of a measured signal. Whereas noise adds, gain error multiplies. Some of the major sources are the IF attenuator, RF connectors, and switch repeatability errors.

Actual Relations

Considering now what actually happens in the whole process, it can be seen that the effect of noise and gain error must be included in every measurement, while

errors in the calibration standards enter into their corresponding measurements. Referring again to the six calibration measurements, and using primes to indicate actual values:

1) Instead of $M_1 = e_{00}$, the computer gets a value

$$M_1' = (1+e_1) (e_{00} + \frac{S e_{01}}{1-S e_{11}} + N_1)$$

Here e_1 is the gain error, N_1 the noise, and S the reflection coefficient of the sliding load. S is not necessarily zero; the Z_0 of the line may not be exactly 50 ohms and the center-finding process is affected by noise.

2) No standards are involved, so

$$M_2' = (1+e_2) (e_{30} + N_2)$$

3) The errors of the direct short itself turn out to be negligible, so

$$M_3' = (1+e_3) (e_{00} - \frac{e_{01}}{1+e_{11}} + N_3)$$

4) The offset short reflection coefficient can be in error in both magnitude and phase, so

$$M_4' = (1+e_4) (e_{00} + \frac{\Gamma S' e_{01}}{1-\Gamma S' e_{11}} + N_4)$$

5) and 6) No standards are involved, so

$$M_5' = (1+e_5) (e_{00} + \frac{e_{22} e_{01}}{1-e_{11} e_{22}} + N_5)$$

$$\text{and } M_6' = (1+e_6) (e_{30} + \frac{e_{32}}{1-e_{11} e_{22}} + N_6)$$

These then are the actual measured values from which the computer derives the model parameters. Re-designating the computer quantities, with ideal quantities in parentheses:

$$(e_{00}) \quad L = M_1'$$

$$(e_{11}) \quad R = \frac{\Gamma S (M_1' - M_3') + (M_1' - M_4')}{\Gamma S (M_3' - M_4')}$$

$$(e_{01}) \quad T = \frac{(1+\Gamma S) (M_1' - M_3') (M_1' - M_4')}{\Gamma S (M_3' - M_4')}$$

$$(e_{30}) \quad L1 = M_2'$$

$$(e_{22}) \quad R1 = \frac{M_5' - M_1'}{T + (M_5' - M_1') R}$$

$$(e_{32}) \quad T1 = (M_6' - M_2') (1 - RR1)$$

In the measurements on an unknown, gain error and noise enter again, so

$$M_{R1}' = (1+e_{R1}) (e_{00} + \frac{s_{11} e_{01} (1-s_{22} e_{22}) + s_{21} s_{12} e_{22} e_{01}}{D_1} + N_{R1})$$

$$M_{T1}' = (1+e_{T1}) (e_{30} + \frac{s_{21} e_{32}}{D_1} + N_{T1})$$

$$M_{T2}' = (1+e_{T2}) (e_{30} + \frac{s_{12} e_{32}}{D_2} + N_{T2})$$

$$M_{R2}' = (1+e_{R2}) (e_{00} + \frac{s_{22} e_{01} (1-s_{11} e_{22}) + s_{12} s_{21} e_{22} e_{01}}{D_2} + N_{R2})$$

The correction then is made by solving for the s-parameters, using these actual measured values and the actual stored values for the model parameters. The problem is to determine the possible error in the resulting calculated s-parameters.

Problem Solution

It can readily be seen that any attempt at a complete explicit solution is pointless since, while the maximum magnitudes of the various terms are known, their phases are, in general, quite unpredictable. Various approaches were taken involving the combining of random-phase terms in the root of the sum of the squares (RSS), or the assignment of phase in steps to different variables in turn. These were all felt very unsatisfactory, because of the interlocking and implicit relations between the terms and because there was no way of determining what the confidence level was.

Finally, it was decided to solve the problem statistically, taking advantage of a computer-driven random-number generator. This is the technique that has resulted in the current accuracy specification.

Each of the random-phase variables — the six model parameters and all the gain error and noise terms — is assigned a phase angle between 0 and 2π at random. The magnitudes of the parameters and the noise are assigned random values between an estimated minimum and the maximum allowed in production testing of the instruments, while the gain error magnitude is the RSS of all the individual contributions. The desired input magnitudes of the s-parameters of the unknown are assigned in the desired steps while their phases are also random. For convenience, s_{11} and s_{22} have the same magnitude, while s_{21} and s_{12} are equal in both phase and magnitude.

The whole process gone through by the 8542A is written into a general-purpose error-analysis program. Actual rather than ideal values are used in all calculations. This yields a set of calculated s-parameters which are compared with the input values to determine their errors. The entire calibration-measurement-correction-comparison process is carried out 100 times, new random magnitudes and angles being assigned each time. The errors in s_{11} and s_{22} and in s_{21} and s_{12} are compared with previous errors and the maximum values are stored. At the end of 100 cycles, the 9 worst values are stored. The program then discards the 8 worst and prints out the 9th worst. Since s_{11} and s_{22} have the same nominal values, in effect there are 200 calculated values of the same quantity compared. Thus the worst 4% are discarded and the printed values correspond to a 96% confidence level. The same applies to s_{21} and s_{12} .

Results

The advantages of this technique are that it gives results of predictable confidence level and that the confidence level may be set at whatever value desired. A smoother set of data can readily be obtained by taking more samples. The curves of Fig. 2 show the complete results for the 8743A in the range from 2 to 12.4 GHz. These curves were obtained with the standard software averaging of from 2 to 12 measurements, depending on signal level. To reduce the effect of noise at low level, the programs may readily be modified to average more measurements. The dotted curve in Fig. 2b was obtained by reducing the noise level by a factor of 10, corresponding to averaging 100 measurements. It shows the substantial improvement in accuracy to be expected.

The results obtained with this technique apply to all 8542A systems in general. A particular system at a given frequency may be consistently better or worse, since some errors taken as random in the general case are systematic in the individual case. However, this suggests the next logical step. Any user with the necessary equipment may determine his own system parameters and put these into the error-analysis program, substituting known magnitude and phase for random magnitude and phase wherever possible. The result after running this program will be an accuracy specification applying to that particular system. The more variables thus processed the better the resulting specification.

Acknowledgement

The constant encouragement and assistance of Richard E. Hackborn are gratefully acknowledged. 🍷

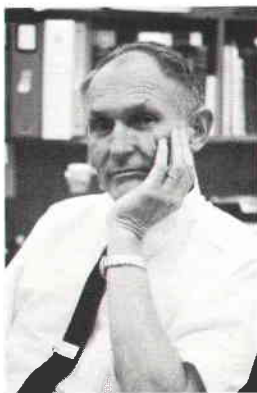

B. P. Hand

Phil Hand has been with Hewlett-Packard since 1947. His degrees include the Bachelor's in EE from Santa Clara and the Master's, also in EE, from Stanford. The list of HP products to which he has made significant contributions is long. Among other microwave products, he was associated with the 430-series of power meters, and the 370, 375, and 382 attenuators during the 1950's. In charge of the Hewlett-Packard Measurement

Standards Laboratory from 1957 to 1968, he recently was named senior technical specialist to the Microwave Division. An authority and a performer on the recorder and other ancient musical instruments, Phil is also an enthusiastic wine-taster and bird-watcher.

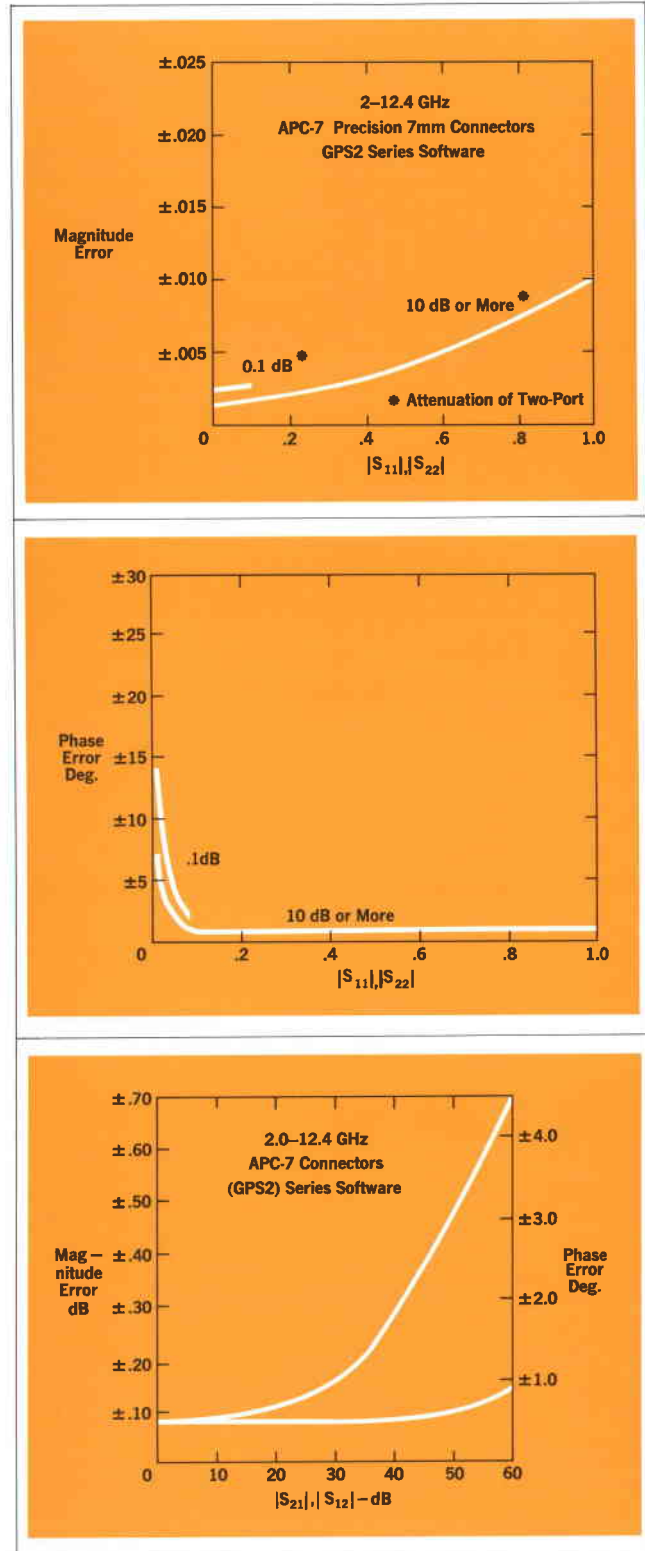

Fig. 2. Curves show complete accuracy results for HP Model 8743A Reflection/Transmission Test Set in the range 2.0 to 12.4 GHz. Dotted curve of Fig. 2b shows improvement in accuracy obtained when noise is reduced by a factor of 10.

Applications of the Automatic Network Analyzer

By Brian Humphries

THE POWER OF THE AUTOMATIC NETWORK ANALYZER lies in its ability to characterize RF and microwave devices completely, accurately, and rapidly, then to process and present the information in almost any way desired. The consequences of this power are perhaps best made evident with examples.

Automatic Component Pre-testing

A key ingredient in some recent advances in microwave microcircuitry has been the ability of the automatic network analyzer to fully characterize both active and passive components before they are committed to final circuits. Some new, small, mechanically tuned oscillators for X and Ku bands use negative resistance devices such as Gunn or Impatt diodes in miniature cavities. It is possible to assure they will perform as desired by analyzing both the devices and the cavities before assembly. To make best use of each diode, one wants to know the frequency range within which its impedance is negative real, and the bias current for optimum negative resistance. Measuring the diode's reflection coefficient in a 50-ohm system, as a function both of frequency and bias, gives the whole story. This fully reveals regions of potential instability, and of optimum behavior. It requires very many tests and calculations, which the automatic analyzer quickly and easily performs. The information can immediately appear on a scope face, if desired, or a teleprinter will make a tabulated record.

The analyzer also speeds the task of tuning the cavity to the desired frequency, and determining the impedance seen by the diode at resonance. The oscilloscope photograph in Fig. 1 shows how the analyzer displays the real and imaginary parts of input impedance from 12.5 to 18.0 GHz, with data displayed every 150 MHz. The in-

strument repeatedly sweeps the band, measuring reflection coefficient at each frequency. It continually calculates impedance and presents the information. The cavity now can be adjusted in real time, with full knowledge of the effect.

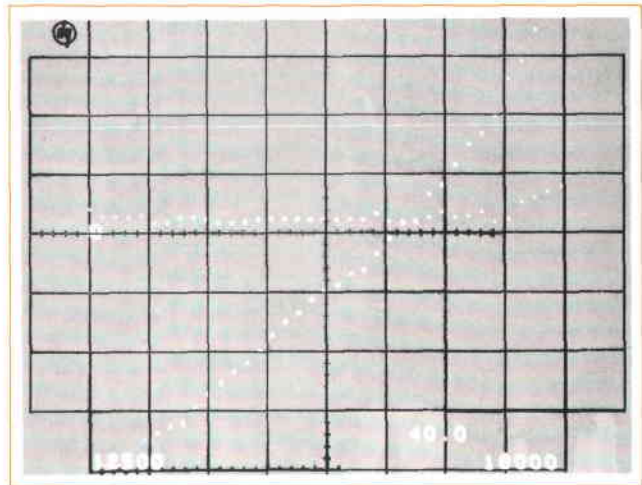

Fig. 1. Scope shows real and imaginary components of tuning cavity impedance. Resonant frequency is easily determined, as is value of impedance at resonance. Vertical scale +40 to -40 Ω , horizontal scale 12.5 to 18.0 GHz with one dot for each 150 MHz.

Automatic Testing for Production Control

A recent hybrid microcircuit amplifier (HP 35005A) delivers 40 dB gain, ± 3 dB, across the band 0.1 to 2.0 GHz. It would have been almost impossible to put it into production without the automatic analyzer's ability to provide process control information during the actual production cycle. The amplifier consists of four sections, each of two stages. The analyzer takes a full set of scat-

tering parameters on each unpackaged transistor. These are then compared with acceptable limits. Transistors thus pre-screened are attached to a substrate containing the passive elements of a two-stage section. The analyzer then fully characterizes this subassembly, listing its s-parameters on a teleprinter. With this information the operator accepts or rejects the device. If the section is accepted, the analyzer then generates a punched paper tape of the information. As many as 97 of these records are now analyzed together on another computer to make an optimum sort of the entire lot, so groups of four may be combined to produce optimum yield of whole amplifiers having the desired overall gain and flatness.

Automatic Finished-product Analysis

Fig. 3 shows the teleprinter output from a program that tests isolator/filters. The analyzer takes VSWR and isolation data, compares the data against preset limits and indicates an out-of-tolerance condition by printing an x in the appropriate column. The program can be instructed to select appropriately among the data, and print out only useful data for that and surrounding points. All the operator need do is answer 'Y' to the question, 'New meas?'; comply with commands to connect the device, and enter the serial number of the unit to be tested.

When equipped with an optional phase-locked signal source, for highest frequency precision, the analyzer is well suited to characterize narrow-band devices. The

scope photos in Fig. 4 show how minutely the analyzer can examine a sharp filter (HP Model 536A Coaxial Frequency Meter).

Frequency Domain to Time Domain Conversion

Much of the analyzer's power is in the many possible mathematical operations by the system computer. With this the analyzer often can derive data which the hardware cannot directly measure. Fig. 5 displays the output resulting from a program which measures reflection coefficient in the frequency domain, then converts the data into the time domain. The time domain information is related to distance, using known propagation velocity, and the results of an equivalent time domain impulse test are displayed on a scope. Here the measurement was of a strip-line transistor fixture connected to a 10-cm airline and terminated in a 50-ohm load. The power of the technique is such that one can realize resolution of the order of 1 cm and sensitivity of 0.001 in reflection coefficient. An added benefit of frequency domain testing is to analyze limited-band systems such as waveguide where time domain reflectometry has been impractical.

Calculating Group Delay

Group delay is given by the derivative of the transmission phase characteristic. All that is required to calculate group delay directly from measured phase information is a program which can approximate the slope of the transmission phase curve. Fig. 6 shows such a measurement

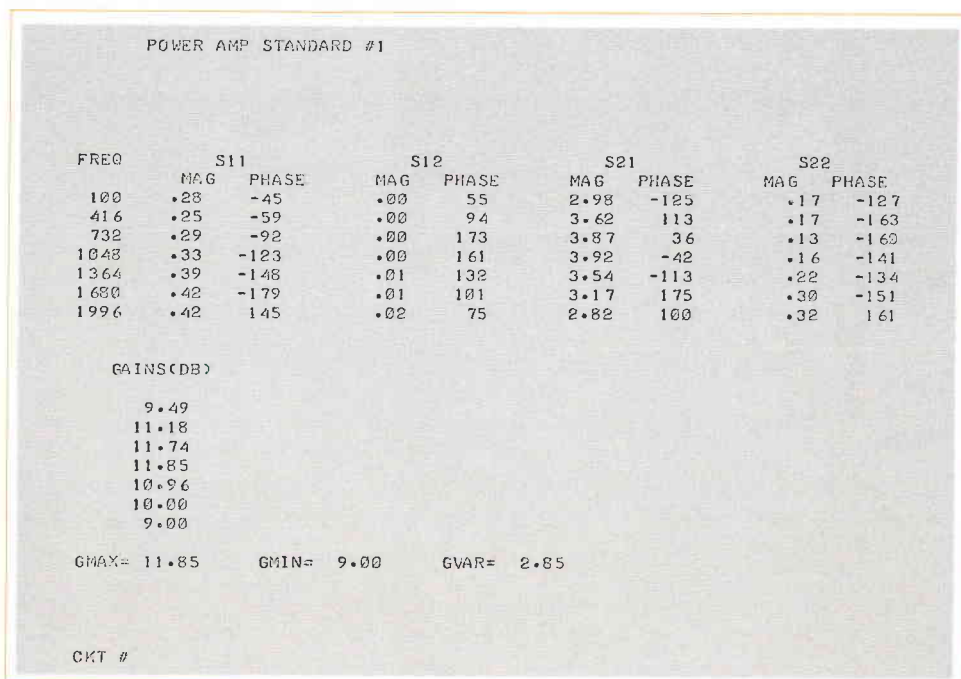

Fig. 2. A typical teleprinter listing gives test operator a quick look at data on two-stage section of 0.1-2.0 GHz amplifier. If gain limits are found to be within specifications, operator commands s-parameter data to be punched on tape for off-line analysis.

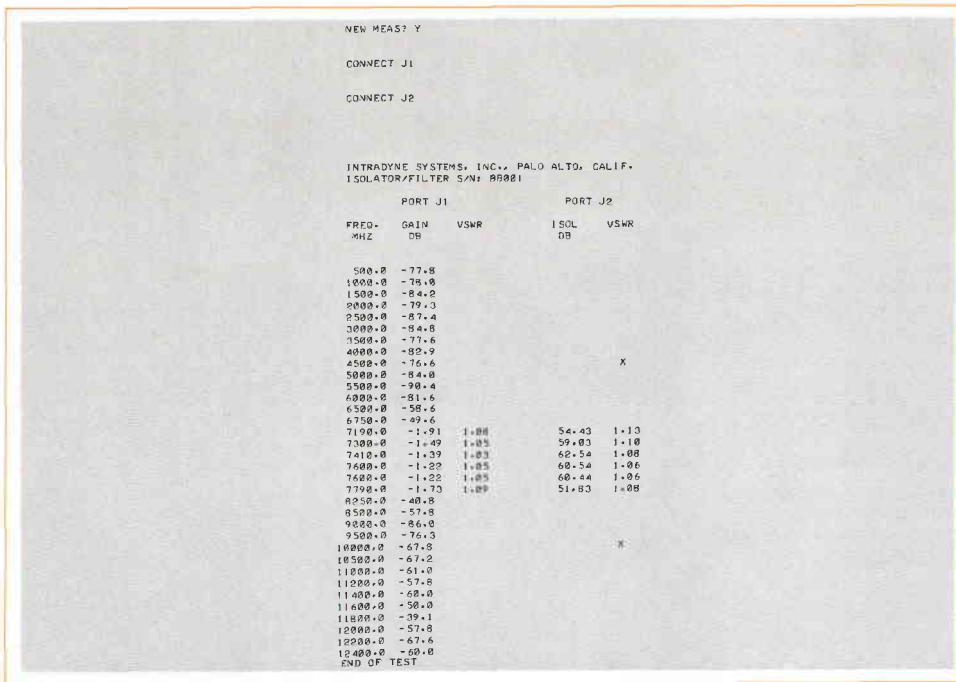
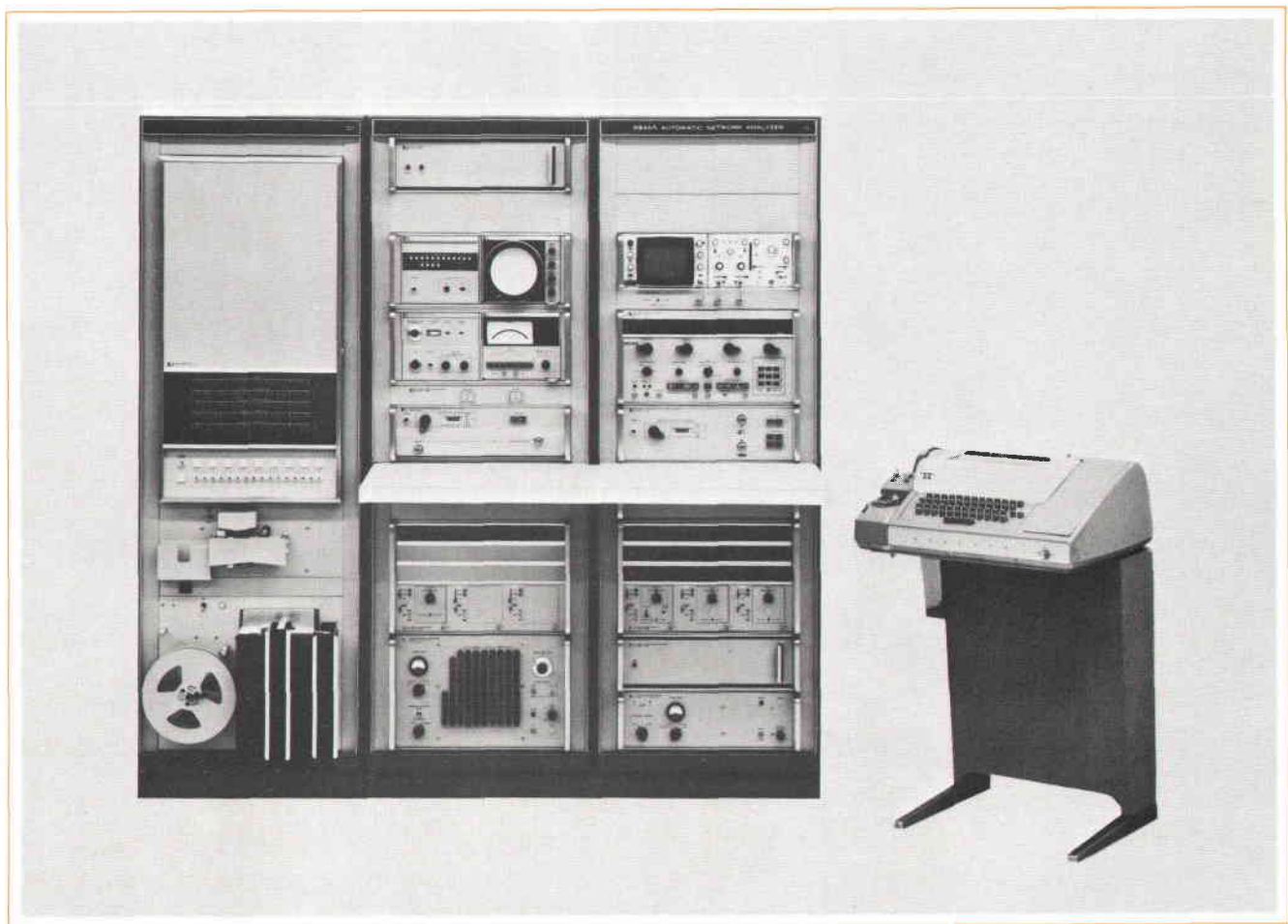

Fig. 3. Printout from a program designed for high-speed production testing of an isolator/filter combination. Note the different frequency intervals above and below the passband, and the indication of specific points of interest within the band. Software instructions selected out these significant points from the welter of other information.



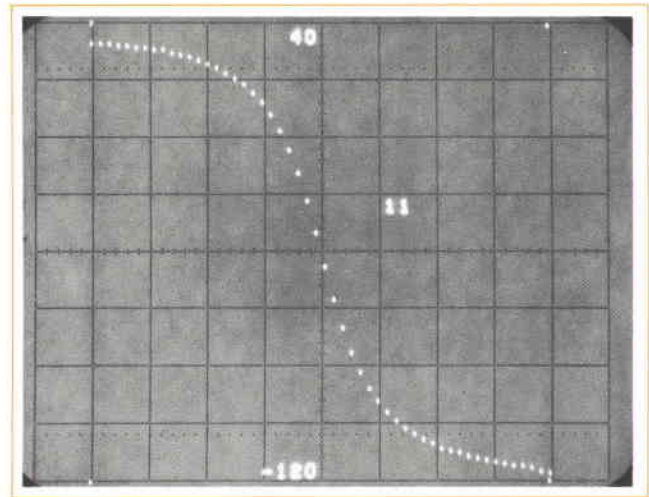
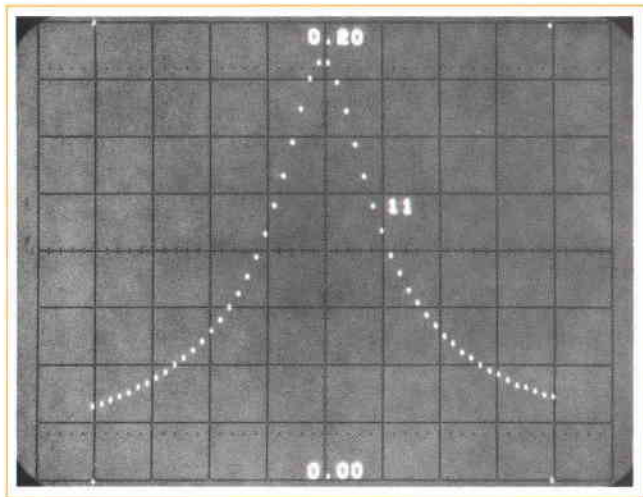
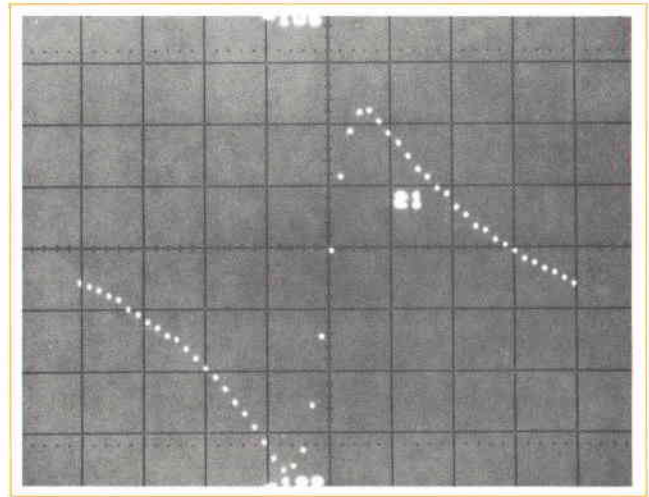
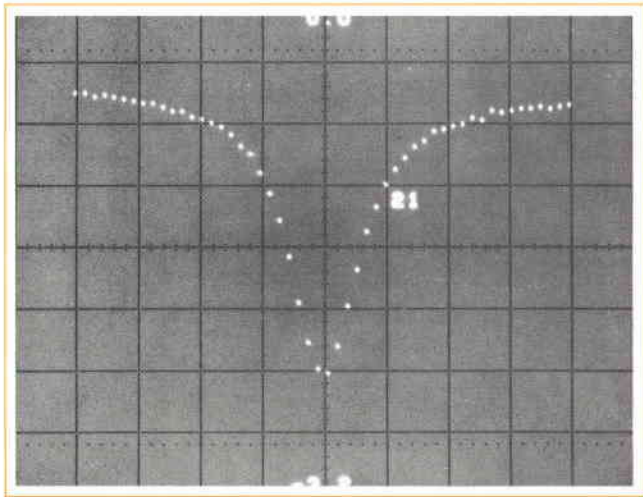



Fig. 4. Transmission and reflection characteristics of sharp filter (HP Model 536A Frequency Meter). Curve of transmission magnitude (above, left) is centered on 3 GHz, vertical scale 0.4 dB/division. Transmission phase characteristic (above, right) is shown at $2^\circ/\text{div}$. Magnitude (lower left) and phase (lower right) of reflection coefficients are shown. Scale factor for magnitude is 0.025/div, and for phase $20^\circ/\text{div}$.

for a 20 cm airline. Theoretical value for an ideal line is 0.66 ns. Good agreement with measured data is evident.

Conclusion

It has been possible here to indicate only broadly, by these few examples, what sort of problems the automatic network analyzer can efficiently solve. Among the many who have contributed application information to us, Mr. Ed Oxner of Intradyne Systems, Inc. is due particular thanks. 

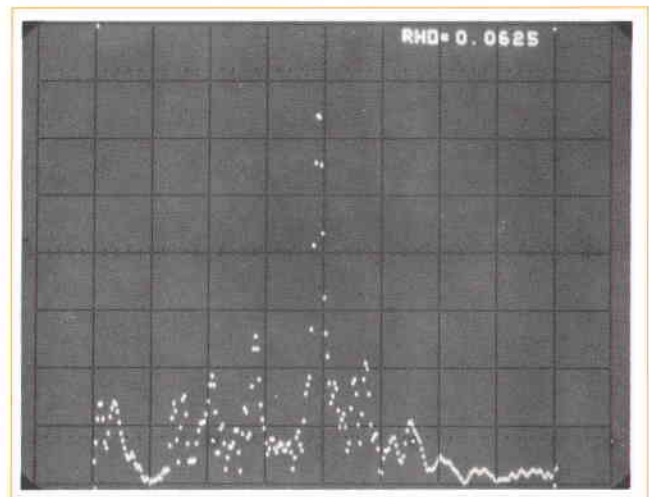

Fig. 5. Reflection coefficient as a function of distance for a stripline transistor fixture fed through a 10 cm airline. Full scale reflection is 0.0625. Full scale distance is 60 cm.

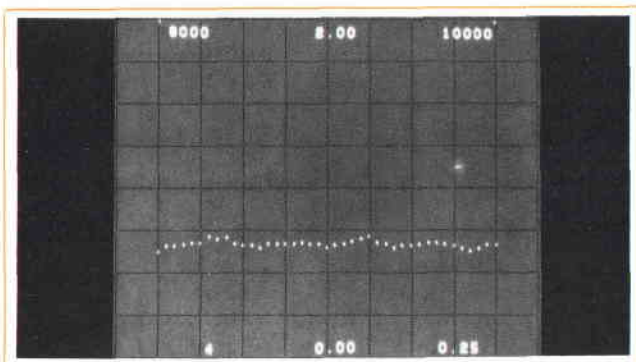

Fig. 6. Group delay of a 20 cm airline. The measurement was made between 8000 and 10,000 MHz. The scale factor is 0.25 ns/div. The theoretical value of group delay for an ideal line is 0.66 ns.



Brian A. Humphries

Brian Humphries is a native of England. His degree is that rarity, a BSc. Brian took it from Leeds University in 1959.

After a year's graduate apprenticeship at Associated Electrical Industries (Rugby, England), he joined HP's U.K. activity, then in Bedford.

Successive assignments in field engineering and sales management led him eventually to his present position as Systems Marketing Manager for the HP Microwave Division,

in Palo Alto. He maintains membership in the British IEE.

SPECIFICATIONS

HP Model 8542A Automatic Network Analyzer

AVAILABLE CONFIGURATIONS AND CAPABILITIES

RF STIMULUS OPTIONS

STANDARD SIGNAL SOURCE

Plug-in oscillator covering 0.11–12.4 GHz with three rf units. Analyzer available with one, two, or three rf units to cover part or all of range. Automatic frequency setting $\pm 0.25\% + 10$ MHz. Max. output power at least 0 dBm, 0.11 to 4.0 GHz, at least +10 dBm, 4 to 12.4 GHz. Broadband power leveling and automatic band selection in multi-band versions.

FREQUENCY-STABILIZED SIGNAL SOURCE

Uses modules from Standard source and incorporates Frequency Synthesizer as precision frequency reference. Resulting source has frequency accuracy ± 1 part in $10^6 + 5$ kHz. Frequency-stabilized source available with fourth rf unit to extend Analyzer coverage to 18.0 GHz.

DC STIMULUS OPTION

DC BIAS SUPPLY

Programmable, dual-output power supply provides ± 30 V ± 0.5 A output to bias transistors, diodes, solid-state amplifiers, etc.

MEASUREMENT OPTIONS

NETWORK ANALYZER

Two channels (reference and test). Makes amplitude and phase measurements from 0.11 to 12.4 GHz (18.0 GHz optional) to determine both reflection and transmission coefficients of device under test. Includes integrating analog-to-digital converter to digitize measured information for data manipulation in the Control and Digital Processor Sub-system, and CRT readout devices for both corrected and uncorrected displays.

TEST SETS

Passive instruments selectively feed proper signals to Network Analyzer to determine both reflection and transmission coefficients of two-port network under test. Contain broadband directional couplers, calibrated line stretcher, and an array of microwave switches. Test sets available: one for frequency range 0.11–2.0 GHz, one for range 2.0–18.0 GHz. Under normal system configurations, power incident on device under test can typically be set manually anywhere between -26 and -2 dBm in the range 0.11 to 2.0 GHz, and between -34 and -14 dBm in the range 2.0 to 18.0 GHz.

Transistor fixtures available to measure TO-18 (TO-72) and TO-5 (TO-12) packaged devices from 0.11 to 2.0 GHz. Accommodate standard lead configurations without need to cut leads.

Bias insertion networks, 50 Ω , apply dc to test device via center conductors of input and/or output coaxial transmission lines. Two different bias tees available, one covering 0.1–3.0 GHz, another covering 1.0–12.4 GHz.

CALIBRATION EQUIPMENT

Calibration programs supplied with 8542A Automatic Network Analyzers require a set of standards for given connector type (APC-7, N, OSM, GR-900) or waveguide size. Each basic calibration kit contains standards common to entire frequency range covered by that connector or waveguide size. Additional standards required in specific frequency ranges are separately available.

CONTROL AND DIGITAL PROCESSING OPTIONS

INSTRUMENTATION COMPUTERS

Choice of Model 2114B (8,192-word, stored-program computer with seven I/O channels, expandable to 24) or Model 2116B (8,192-word stored-program computer, with 16,384-word option, sixteen I/O channels, expandable to 48. High-speed punched tape input is standard with each computer. Optional memory expansion: both magnetic tape and disc memory peripherals are available.

INPUT/OUTPUT OPTIONS

TELEPRINTERS

Model 2572A (modified ASR-33) for systems where teleprinter use is 5 hours per day or less; for heavier duty, Model 2754B (modified ASR-35) is available.

PUNCHED TAPE OUTPUT

120 character/second tape punch, recommended for systems expected to deliver considerable hard-copy output or where FORTRAN is anticipated to modify standard software. (Both teleprinters have punched tape output of more limited speed and format.)

OSCILLOSCOPE

Measurement subsystem includes CRT display of polar or rectangular plots, corrected or uncorrected, in usual size screens. Large-screen scope, readable at distances up to 10 feet, optional.

X-Y PLOTTER

Optional X-Y point plotter makes hard copy replicas, up to 11" x 17", of any oscilloscope display. Typically a 50-point display can be transferred in less than 15 seconds, including alpha/numeric labels.

HEWLETT-PACKARD JOURNAL FEBRUARY 1970 Volume 21 • Number 6

TECHNICAL INFORMATION FROM THE LABORATORIES OF THE HEWLETT-PACKARD COMPANY PUBLISHED AT 1501 PAGE MILL ROAD, PALO ALTO, CALIFORNIA 94304
Editor: R. H. Snyder Editorial Board: R. P. Dolan, L. D. Shergalis Art Director: Arvid A. Danielson Assistant: Maridel Jordan

HP Archive

This vintage Hewlett-Packard document was
preserved and distributed by

www.hparchive.com

Please visit us on the web!

On-line curator: John Miles, KE5FX

jmiles@pop.net

