

# HEWLETT-PACKARD JOURNAL

WIDEANGLE LENS LOOKS AT WIDEBAND SWEEPER; page 2

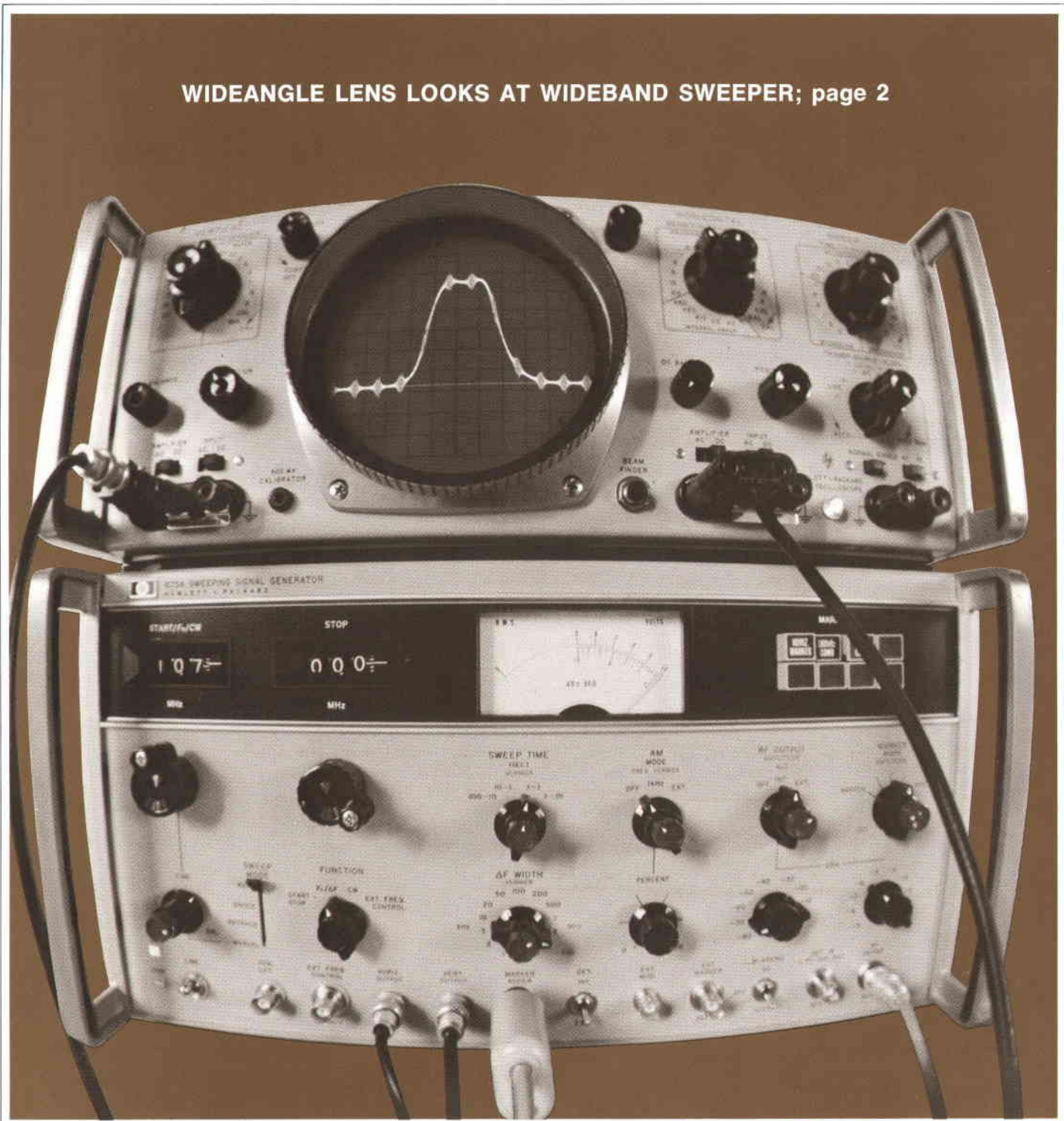

JANUARY 1968

# Three and One-Half Decades in One Clean Sweep

*New high-accuracy sweep generator covers 10 kHz to 32 MHz in one range with low residual FM*

**By Robert B. Bump and Myles A. Judd**

**O**SCILLOSCOPE DISPLAYS OF SWEEPED FREQUENCY TRACES should be compatible in accuracy with precise point-by-point plots on graph paper. However, a sweep oscillator with superior accuracy specifications must also be easy to operate. Measurement speed gained with a swept technique could be negated if measurement time were increased due to complicated controls and operating procedures.

Sweepers generally cannot produce an accurate scope display, and it is often necessary to spot-check points of interest to achieve the desired accuracy. Besides the lack of accuracy, some of these instruments are complicated to operate. Ideally, the sweeper should be able to produce a display as accurate as a plotted curve and be as easy to operate as a modern signal generator.

Many innovations have been combined in a new 10

kHz to 32 MHz sweep oscillator, Fig. 1, to achieve point-by-point accuracy of measurement without sacrificing speed. The new sweeper has a linearity of  $\pm 0.5\%$  of sweep width, a dial accuracy of  $\pm 0.5\%$  and an overall system flatness (sweeper plus its internal detector) of better than 0.25 dB. Sweep and CW output signals are available over the three and one-half decade frequency range in one band on an easy-to-read 3-place digital dial.

Non-interacting, calibrated controls set the two endpoints in either start-stop sweep or the delta sweep mode. Delta sweep, or  $f_c/\Delta f$ , is used where very narrow, calibrated sweeps are desired, especially where the start-stop sweep dials cannot be read that accurately. It is possible to set the center frequency to within 0.5% of full scale and have calibrated sweep around that frequency. Sweep width can be read at a glance without the need for subtracting any numbers.

Sweep time is continuously variable from 0.01 to 100 seconds. Manual and single sweep is provided. Residual (line related) FM is less than 70 Hz peak, which prevents degradation of the sweep at narrow widths. Both RF and vertical (dc) blanking are provided.

## Theory of Operation

Mixing of a variable 100 to 132 MHz signal with a fixed, crystal-controlled 100 MHz signal, Fig. 2, results in the 0 to 32 MHz output frequency. Dial accuracy, frequency stability and sweep linearity are all dependent upon the variable 100 to 132 MHz signal. These requirements, along with the need for electronic



Fig. 1. Covering 10 kHz to 32 MHz in a single sweep, the new HP Model 675A Sweeping Signal Generator makes swept measurements with an accuracy approaching that of precision point-by-point plots.

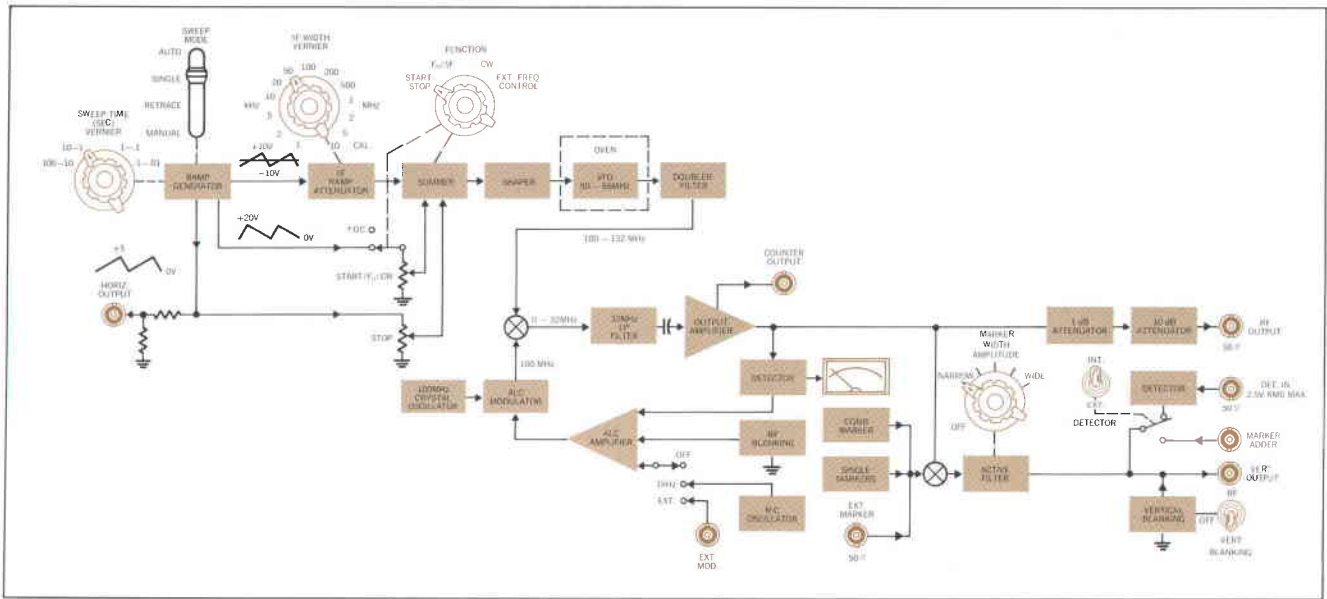

Fig. 2. To maintain frequency stability with temperature, the entire variable-frequency oscillator is placed in a proportionally-controlled oven.

tuning, indicated a preference for a voltage-variable capacitor and field effect transistors in the VFO, Fig. 3. The VFO output frequency is 50 to 66 MHz and is doubled and mixed with the 100 MHz crystal frequency.

The voltage-variable capacitor is the dominant capacitance in the VFO tank circuit, and a control voltage determines the VFO output frequency. To reduce unwanted FM, a high Q tank circuit is needed, which requires high output impedance of the driver stage and high input impedance of the following stage. These requirements are well met at these frequencies by field effect transistors. Diode limiting stabilizes the oscillator output level, and an emitter follower provides a low output impedance to drive a coaxial cable, followed by an amplifier which drives the frequency doubler.

A proportionally-controlled oven maintains the entire VFO at a constant temperature.

### Sweep Control Circuitry

Since the capacitance of a voltage variable capacitor varies approximately as the inverse square root of applied voltage, and the frequency of an LC oscillator also varies as the inverse square root of capacitance, the frequency of the VFO is roughly proportional to the fourth root of the applied voltage. To achieve a precisely linear sweep it is necessary to compensate for this non-linear voltage-to-frequency characteristic. A 16-line segment diode-shaping network modifies the control voltage so that the output frequency is directly proportional to the control voltage within  $\pm 0.5\%$ .

The control voltage is generated by summing ramps, adjustable dc voltages, or externally applied signals depending on the function desired. In Start-Stop sweep, where the end points are set, a ramp is applied to a ten-turn potentiometer which sets the frequency at which the sweep starts, Fig. 4. Another ramp, the inverse of the first, is fed to a similar pot which sets the frequency at which the sweep stops. The outputs of these pots are summed to produce a control voltage ramp representing the difference between the pot settings. The output frequency starts at one setting and stops at the other, allowing completely independent sweep end points and up-or-down-going sweep frequency.

In delta sweep, the  $F_0$  pot sets a dc voltage which determines the center frequency. A ramp with no dc component is added to the dc, and the amplitude of the ramp determines the delta-sweep width. Because of this, the

**On the Cover:** Wideband capabilities of the Model 675A Sweep Generator are dramatized by photographer George Ward in this 'fish-eye' lens photo. Here, the Model 675A, in the  $f_0/\Delta f$  mode, is sweeping a 10.7 MHz IF amplifier, and 1 MHz comb markers can be seen on the display.

**Also in this Issue:** Advances in Spectrum Analysis; page 7. How a YIG Filter Works; page 9.

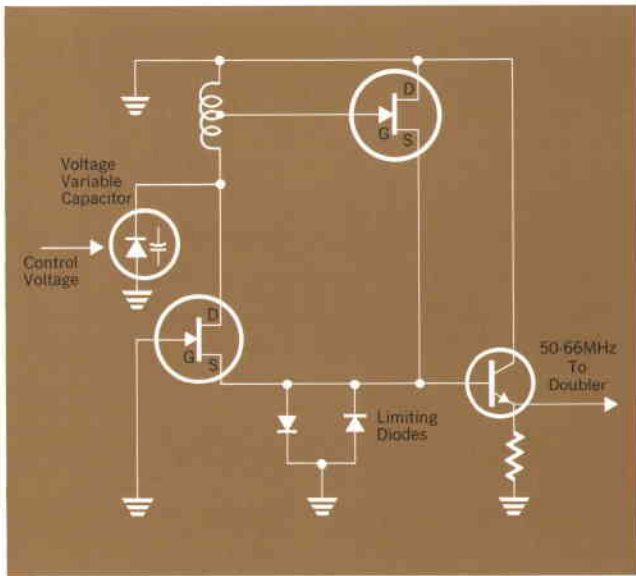

Fig. 3. Equivalent circuit of the variable-frequency oscillator. Field effect transistors were used to provide the high  $Q$  in the tank circuit to reduce unwanted FM.

controls setting center frequency and sweep width are independent. In CW operation, only the dc from the pot determines the output frequency.

In External Frequency Control, an externally applied

voltage is summed with the dc from the CW control. If frequency modulation is desired, the CW control can be used to set the carrier and an ac-coupled external voltage will determine the modulation. To use the Model 675A for programming or voltage-to-frequency conversions, the CW control can be set to zero, and a dc-coupled external voltage will determine the output frequency.

Reference power supplies, from which the control voltages are derived, have to be very clean and stable for low residual FM and long-term frequency stability. The built-in reference supplies are regulated once to provide hum and ripple reduction and line regulation, and a second time to obtain long term stability and low noise. A temperature compensated zener diode is located in the VFO oven to provide an invariant reference voltage for these supplies. These reference supplies have noise levels of less than  $4 \mu\text{V}$ ; the control circuitry has less than  $2 \mu\text{V}$ .\*

### Markers

If accuracy greater than that offered by a CRT graticule is needed, or if test limits are to be indicated for repeated operations, a system of by-pass markers are available. Crystal-derived harmonic comb markers at

\* Techniques used in measuring these low noise levels are described in the article by Robert B. Bump entitled 'Increasing Instrument Sensitivity with a Low Noise Pre-amplifier,' 'Hewlett-Packard Journal,' Vol. 17, No. 11, July 1966, page 14.

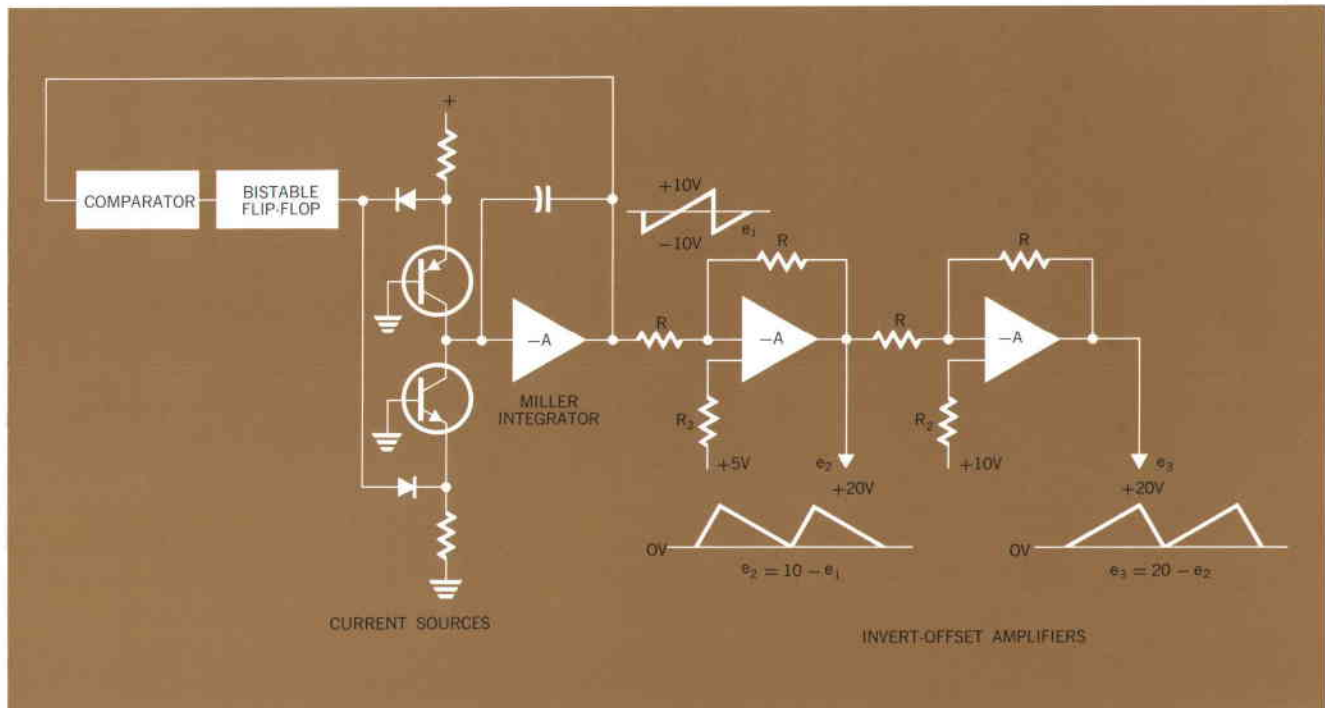

Fig. 4. This ramp circuitry provides the control signal fed to the VFO. So that swept frequency is linear with time, the constant current source charges a Miller integrator capacitor which creates a highly-linear ramp. Two additional ramps required by the Start-Stop function are obtained by the pair of invert-offset operational amplifiers shown.

100 kHz or 1 MHz intervals are available as an option, and single crystal markers can be obtained for any frequency from 100 kHz to 32 MHz. These markers are created by mixing marker frequencies with the sweep output frequency and using an active low-pass filter to obtain a beat note. When the output frequency is equal to the marker frequency, a signal passes through the filter and appears as a marker on the swept display, giving precise frequency identification.

The device under test is in this way bypassed by the marker frequencies and is only affected by the sweep frequency. Bandwidth and amplitude characteristics of the active filter are adjustable from the front panel, allowing the width and size of the markers to give accurate frequency identification without obliterating the trace. Marker controls and a jack for external marker frequencies are included on the standard instrument. Marker widths are variable and markers may be tilted by 90° for better frequency identification on steep skirts.

#### Manual Sweep

For maximum precision of frequency readout at any point on a response curve, the sweeper can be switched to manual sweep. The frequency at the point of interest can be read out on a counter from a rear-panel unattenuated jack. Manual sweep also saves time in setting up an X-Y recorder. Sweep speeds down to 100 seconds are provided on the Model 675A. These are compatible with X-Y recorders.

#### Blanking

Two types of blanking are provided—RF and vertical. Turning the RF on and off through the device has been the standard method of blanking the retrace. However, switching the RF on and off through a device may not always be desirable. In a high-Q tank circuit, for example, turning the RF on and off abruptly may result in a transient, which might show on the display. Where a detector has a relatively slow decay, the decay manifests itself as a curved baseline when the RF is turned off. Therefore vertical blanking, in which the vertical output is grounded during retrace, is provided. In other words, the RF is always on, but the detected signal is turned off.

#### Applications

Because the HP Model 675A covers 3½ decades in a single sweep, it is possible to see the entire frequency response curve of many wideband devices, Fig. 5. Some telephone repeaters, for example, are spec'd from 60 kHz to 20 MHz. In checking these repeaters, wide bandwidth

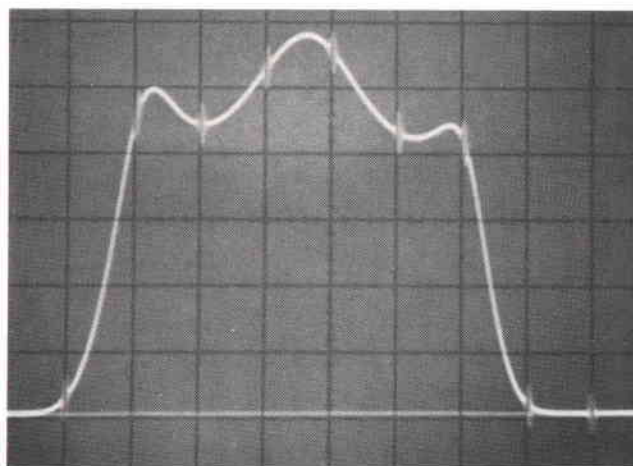

Fig. 5. Bandpass filter response from 11 to 21 MHz showing 1 MHz comb markers positioned exactly on each vertical line of the graticule.

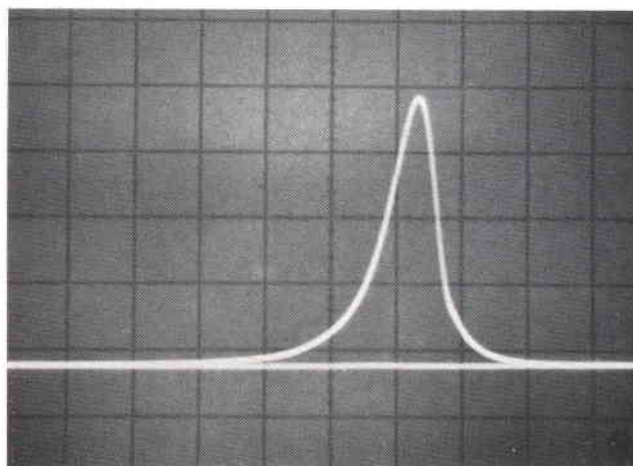

Fig. 6. Very low residual FM enables presentation of narrow sweep widths such as this crystal filter. This is a 20 kHz sweep width and the bandwidth of the filter is 1.5 kHz.

viewing simplifies adjustment of controls, since any interaction between adjustments can be seen on the display.

In checking wideband amplifiers, the wide sweep width reduces the possibility of missing anomalies in the response curve. For example, there may be a dip due to power supply resonance, and the effects of power supply bypassing may be seen immediately.

Narrow band sweeps are practical due to low residual FM of less than 70 Hz peak. Calibrated delta sweep from 1 kHz to 10 MHz makes narrow-band measurement convenient and fast. Bandwidth of the crystal filter, Fig. 6, is 1.5 kHz, and the effect on the display by residual FM is negligible. With an accurate sweep, it is possible to ex-

## SPECIFICATIONS

### HP Model 675A Sweeping Signal Generator

**FREQUENCY RANGE:** 10 kHz to 32 MHz in one range.

**OUTPUT:**

Maximum +13 dBm (1 V rms into 50  $\Omega$ , 2 V rms open circuit).  
Continuously adjustable.  
Impedance: 50  $\Omega$

**RF FLATNESS**

**INTERNALLY LEVELED:**  
50 kHz to 200 kHz:  $\pm 1$  dB;  
200 kHz to 32 MHz:  $\pm 0.15$  dB.

**SYSTEM FLATNESS**

**USING INTERNAL RF DETECTOR, INTERNALLY LEVELED:**

10 kHz to 50 kHz:  $\pm 1$  dB;  
50 kHz to 200 kHz:  $\pm 0.4$  dB;  
200 kHz to 32 MHz:  $\pm 0.25$  dB.

**INTERNAL DETECTOR OUTPUT (VERTICAL):** At least 1.2 V dc for 1 V rms.

**ATTENUATOR**

RANGE: 99 dB in 10 and 1 dB steps.  
ACCURACY:  $\pm 0.3$  dB, +10 dB to -12 dB.  
 $\pm 0.4$  dB, -13 dB to -89 dB +6  $\mu$ V constant error.

**OUTPUT MONITOR**

RANGE: -3 to +3 dB (0.5 V to 1 V).  
ACCURACY:  $\pm 0.3$  dB, 200 kHz-32 MHz.

**COUNTER OUTPUT:**

>300 mV rms.

**DISTORTION**

HARMONIC: >30 dB down from fundamental.  
SPURIOUS: >50 dB down from fundamental.

**RESIDUAL (line related) FM:** <70 Hz peak.

**SPURIOUS FM:** <60 Hz rms.

**FREQUENCY DRIFT:** <1 kHz/hr, <3 kHz/ $^{\circ}$ C.

**AUXILIARY OUTPUT (rear panel):** 100 MHz to 132 MHz unlevelled.

**SWEEP FUNCTIONS**

**LINEARITY:**  $\pm 0.5\%$  of sweep width  $\pm 100$  Hz.

**START-STOP:** Sweeps up or down from start to stop frequency settings.

**RANGE:** 10 kHz to 32 MHz.

**END POINT ACCURACY:**

$\pm 1\%$  of full scale, 20 $^{\circ}$ C to 30 $^{\circ}$ C.

$\pm 2\%$  of full scale, 0 $^{\circ}$ C to 20 $^{\circ}$ C, 30 $^{\circ}$ C to 50 $^{\circ}$ C.

**F<sub>0</sub>/ $\Delta$ F:** Sweeps  $\Delta$ F centered on F<sub>0</sub> setting.

**F<sub>0</sub> RANGE:** 10 kHz to 32 MHz.

**F<sub>0</sub> ACCURACY:**  $\pm 0.5\%$  of full scale.

**$\Delta$ F WIDTH:** Continuously adjustable from 200 Hz to 10 MHz, or calibrated steps in 1-2-5 sequence from 1 kHz to 10 MHz.

**$\Delta$ F WIDTH ACCURACY:**  $\pm 5\%$  of calibrated steps  $\pm 100$  Hz.

**SWEEP MODES**

**AUTO:** Repetitive sweeps.

**SINGLE:** Beginning-to-end sweep.

**RETRACE:** End-to-beginning retrace.

**MANUAL:** Manual control of sweep and retrace.

**SWEEP TIME:** 0.01 s to 100 s  $\pm 20\%$ ; 4 decade steps with vernier.

**RETRACE TIME:** 0.01 s for 0.01 s to 1 s sweep times.  
1 s for 1 s to 100 s sweep times.

**HORIZONTAL OUTPUT:** 0 to +5 V dc.

**BLANKING**

**RF:** RF output off during retrace.

**VERTICAL:** Vertical output shorted to ground during retrace.

**PEN LIFT:** Terminal shorted during sweep, open during retrace.

**CRYSTAL MARKERS (optional):** 100 kHz, 1 MHz harmonic comb and/or up to 5 fixed frequencies\* from 100 kHz to 32 MHz.

ACCURACY:  $\pm 0.005\%$  of frequency.

WIDTH: Adjustable 5 steps, 4 kHz to 100 kHz.

\* HP 11300A single frequency marker (frequency must be specified).

**EXTERNAL MARKER:** Front-panel BNC input (50  $\Omega$  impedance), 50 mV to 500 mV rms.

**SIGNAL GENERATOR FUNCTIONS**

**CW DIAL ACCURACY:**

$\pm 0.5\%$  of full scale, 20 $^{\circ}$ C to 40 $^{\circ}$ C.

$\pm 1\%$  of full scale 0 $^{\circ}$ C to 20 $^{\circ}$ C, 40 $^{\circ}$ C to 50 $^{\circ}$ C.

**CW SETTABILITY:** 1 kHz.

**CW RESOLUTION:** 20 kHz.

**INTERNAL AM:** 0% to 50% sinusoidal 985 Hz to 1015 Hz continuously adjustable.

**EXTERNAL AM:**

0% to 50%, dc to kHz leveled.

0% to 50%, 50 Hz to 600 kHz unlevelled.

SENSITIVITY: At least 50% for 2.5 V rms input.

**EXTERNAL FREQUENCY CONTROL AND EXTERNAL FM**

SENSITIVITY: 1 MHz/V.

INPUT IMPEDANCE: 1 M  $\Omega$ .

RATE: DC to 4 kHz. Above 4 kHz the range and sensitivity decrease 20 dB/decade.

**GENERAL**

**TEMPERATURE RANGE:** 0 $^{\circ}$ C to 50 $^{\circ}$ C.

**POWER:** 115 V or 230 V  $\pm 10\%$ , 50 Hz to 1000 Hz, <80 W.

**WEIGHT:** Net 46 lb. (20.8 kg), shipping 51 lb. (23.2 kg).

**PRICE:** HP 675A, \$2250.00.

**MANUFACTURING DIVISION:** LOVELAND DIVISION

P.O. Box 301

815 Fourteenth Street S.W.

Loveland, Colorado 80537

periment with filters without the need for a great deal of calculation.

Frequently an application requires a sweep just beyond the 32 MHz range of the Model 675A. A typical case would be a response check of a 30 MHz IF amplifier where the response from 23 to 37 MHz is desired. Here, a doubler can be used with the sweeper to extend its range. Combined system flatness is better than 0.25 dB from 4 to 64 MHz with the greatest deviation at 64 MHz. Marker width is not affected.

## Acknowledgments

The authors would like to recognize the contributions to the Model 675A by the other members of the design team. Paul Thomas was responsible for the design of the marker circuitry. Gerald Nelson designed the power supplies, oven and oven controls and also contributed to the design of the variable frequency oscillator. Arthur Minich designed the attenuators. Kay Danielson did the product design, and Brian Smith gave valuable assistance in testing and breadboarding. 📷



### Robert B. Bump

Bob Bump received his BSEE in June, 1962, from California Institute of Technology, and joined the HP Loveland Division as a development engineer immediately after graduating. He did the electronic design of the HP Model 208A Test Oscillator and the HP Model 465A General Purpose Amplifier, and had project responsibility for the 675A Sweeping Signal Generator.

Bob received his MSEE in December, 1966 from Colorado State University on the HP Honors Cooperative Program.

In September, 1967 he transferred to the Avondale, Pennsylvania Division, where he is currently project leader of an electrometer investigation team.



### Myles A. Judd

Myles received his Bachelor of Engineering Science degree from Brigham Young University in 1962.

He joined the Loveland Division research and development laboratory as a development engineer in that year. Since joining HP, Myles has worked on several test oscillators including the Models 651A and 652A. He also worked on the 236A Telephone Test Oscillator and the Model 313A Tracking Oscillator.

He is presently a group leader and is continuing work related to this area.

# Advances in Spectrum Analysis

*A new preselector, variable persistence with storage, better sensitivity, and flatter frequency response make spectrum analysis considerably easier and more powerful.*

**By John J. Dupre, Richard C. Keiter, and John R. Page, Jr.**

**A**lthough spectrum analysis has been an important signal-analysis tool for twenty-five years, it has made its greatest strides in the three years since 1964, when the first accurately calibrated microwave spectrum analyzer was developed. It now seems probable that the spectrum analyzer will one day be almost as common and as necessary as the oscilloscope. Tending to strengthen this conviction are several recent developments, chiefly new capabilities for dealing with certain types of signals that have traditionally been difficult to analyze.

Aiding in the analysis of strong signals, multiple signals, and broadband signals is a versatile new preselector for the HP spectrum analyzer. This instrument is a voltage-tunable YIG filter which automatically tracks a selected harmonic of the analyzer's local oscillator, so that only signals in a single frequency range are displayed. It can also be used separately as a voltage-tuned or manually tuned filter.

A new variable-persistence display unit for the spectrum analyzer significantly enhances the analyzer's ability to measure intermittent, low-level, and low-repetition-rate signals. It also makes it convenient to use slower sweeps, which are necessary for maximum resolution.

Greater accuracy in measuring widely spaced and low-level signals comes from a new broadband input mixer, which extends the upper limit of the analyzer's coaxial range to 12.4 GHz. The mixer has greater sensitivity and flatter frequency response than its predecessor.

## **Preselector**

The broadband harmonic input mixer and wide-sweeping first local oscillator in the HP spectrum analyzer allow simultaneous observation of all input signals between 10 MHz and 12.4 GHz. The analyzer acts like a wide-open superheterodyne receiver. It accepts, in coax, any input signals between 10 MHz and 12.4 GHz, and mixes them with the fundamental and the harmonics of a local oscillator which sweeps from 2 GHz to 4 GHz. (The harmonics are generated in the mixer.) The result-

ing IF signals, centered at 2 GHz, are converted down to 20 MHz, amplified and detected, and displayed on the CRT.

This wide-open, untuned input system is an advantage when widely spaced signals must be observed simultaneously. Tuning a parametric amplifier is one such occasion; signal, pump, and idler frequencies can be seen on a single display. Another task which calls for a wide spectrum display is observing the output of a varactor multiplier chain.

However, there are situations when the untuned input, combined with the action of the harmonic input mixer, can make the display difficult to interpret. For example, 1 GHz on the display also corresponds to input frequencies of 4, 5, 7, 8, and 11 GHz; thus signals separated widely in frequency can appear close together. Also, a single input signal can produce responses at more than one point on the display. Hence the display can become ambiguous and complicated, especially if there are several input signals.

Display ambiguities can be eliminated by using frequency-selective circuitry (preselection) ahead of the input mixer to confine the displayed signals to a definite frequency range. The HP Model 8441A Preselector, designed primarily for use with the HP spectrum analyzer, employs an Yttrium-Iron-Garnet (YIG) bandpass filter whose center frequency is electrically tunable from 1.8 to 12.4 GHz. The preselector obtains from the spectrum analyzer a tuning voltage proportional to the analyzer's local-oscillator frequency. Its center frequency then automatically tracks a selected harmonic of the spectrum analyzer's local oscillator, with a frequency offset equal to the intermediate frequency. Thus only signals in a selected frequency range can reach the mixer and be displayed on the CRT. Nominal bandwidth of the preselector is 40 MHz, wide enough to avoid interference with desired signals (maximum IF bandwidth of the analyzer is 1 MHz), but narrow enough to provide good rejection of most unwanted signals.

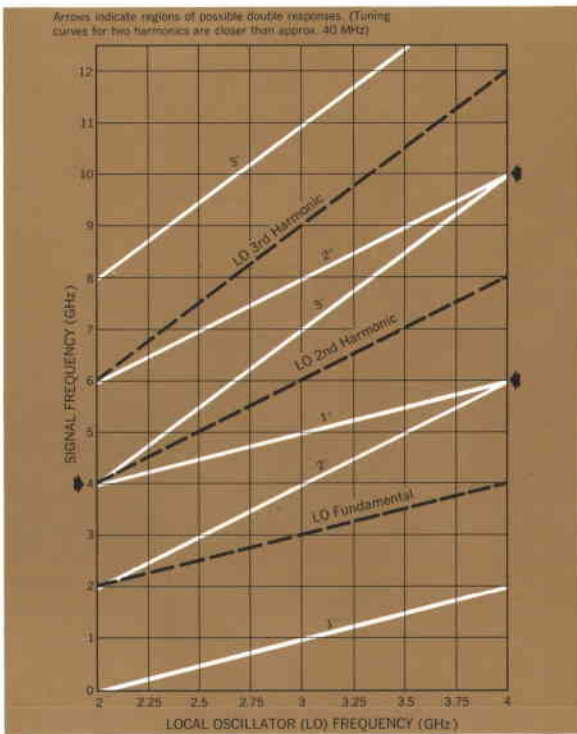

Fig. 1. Coaxial input mixer of HP spectrum analyzer converts input signals to 2-GHz intermediate frequency. An IF response is produced whenever  $f_s = n f_{LO} \pm 2 \text{ GHz}$ , where  $n = 1, 2, 3, 4, \dots$

### Responses of the Harmonic Mixer

To understand multiple responses and how the preselector rejects them, consider the tuning curve for the spectrum analyzer, Fig. 1. This is a graphical presentation of the harmonic mixing responses of the spectrum analyzer. A signal of frequency  $f_s$  produces a response whenever

$$f_s = n f_{LO} \pm f_{IF}$$

where  $f_{LO}$  = first-local-oscillator frequency, 2 to 4 GHz,

$f_{IF}$  = first intermediate frequency, 2 GHz

(A 200 MHz IF can also be selected, for observing signals in the vicinity of 2 GHz),

$$n = 1, 2, 3, \dots$$

Responses produced by a particular harmonic with a plus or minus sign in the above equation are spoken of as having been generated by the  $n^+$  or  $n^-$  mixing modes, respectively.

### Harmonic Responses

Without preselection, the analyzer will respond to several different input frequencies for a particular local-oscillator setting. For example, if the local-oscillator frequency is 3 GHz, the analyzer will respond to signals at 1, 4, 5, 7, 8, and 11 GHz. Corresponding mixing modes are  $1^-$ ,  $2^-$ ,  $1^+$ ,  $3^-$ ,  $2^+$ , and  $3^+$ .

Harmonic responses like these can be prevented by the preselector. The preselector is connected to the analyzer as shown in Fig. 2, and a front-panel switch on the preselector is turned to the desired mixing mode. The preselector's center frequency then automatically tracks the proper harmonic of the analyzer's local oscillator —

offset above or below it by an amount equal to the first intermediate frequency — so that only responses produced by the desired mixing mode are displayed. Only where the tuning curves for two mixing modes come within approximately 40 MHz of each other is there a possibility that an unwanted harmonic response can occur. Such areas are indicated in Fig. 1; they can be avoided by selecting another mixing mode.

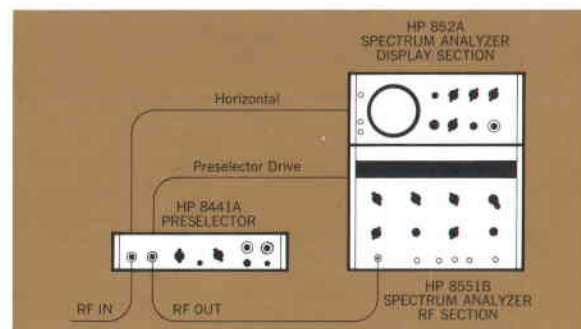
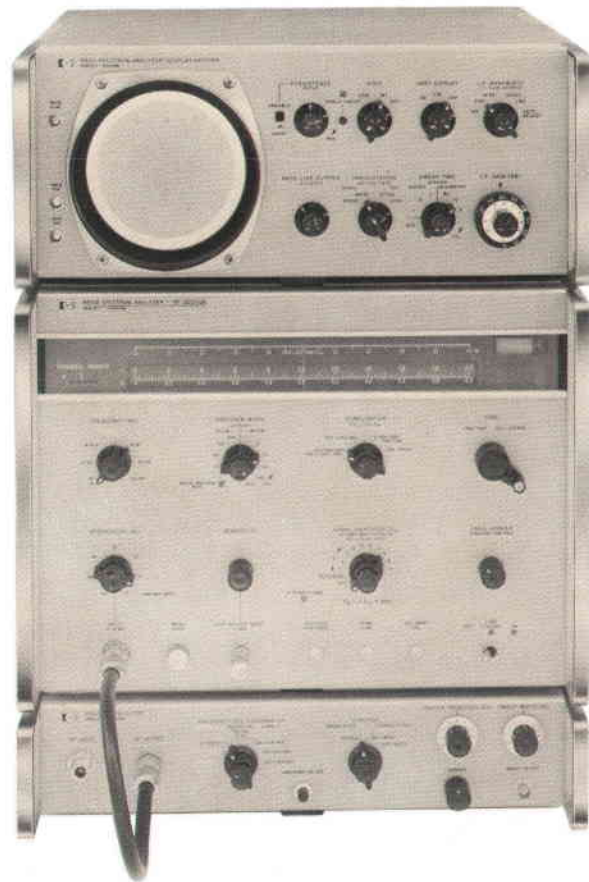

Fig. 2. New HP Model 8441A Preselector, connected to spectrum analyzer as shown, confines displayed signals to a selected frequency range. The preselector is a narrow-band YIG filter which automatically tracks a selected harmonic mixing mode of the analyzer's LO and mixer.

## How a YIG Filter Works

The electrically tunable filter used in the Preselector described in the accompanying article is of the recently developed Yttrium-Iron-Garnet (YIG) type. Highly polished spheres of single-crystal YIG, a ferrite material, when placed in an RF structure under the influence of a dc magnetic field, exhibit a high-Q resonance at a frequency proportional to the dc magnetic field.

To understand the phenomenon of ferrimagnetic resonance, consider diagrams (a) through (e). In the ferrite with no dc magnetic field applied, there is a high density of randomly oriented magnetic dipoles, each consisting of a minute current loop formed by a spinning electron. Viewed macroscopically, there is no net effect because of the random orientations. When a dc magnetic field,  $H_0$ , of sufficient magnitude is applied, the dipoles align parallel to the applied field, producing a strong net magnetization,  $M_0$ , in the direction of  $H_0$ . If an RF magnetic field is applied at right angles to  $H_0$ , the net magnetization vector will precess, at the frequency of the RF field, about an axis coincident with  $H_0$ . The precessing magnetization vector may be represented as the sum of  $M_0$  and two circularly polarized RF magnetization components  $m_x$  and  $m_y$ . The angle of precession  $\phi$ , and therefore the magnitudes of  $m_x$  and  $m_y$ , will be small except at the natural precession frequency. This frequency, known as the ferrimagnetic resonant frequency, is a linear function of the dc field  $H_0$ .

Diagram (f) shows the basic elements of a YIG bandpass filter.<sup>1</sup> The filter consists of a YIG sphere at the

center of two loops, whose axes are perpendicular to each other and to the dc field  $H_0$ . One loop carries the RF input current, and the other loop is connected to the load. When  $H_0$  is zero there is large input-to-output isolation, since the two loops are perpendicular. With  $H_0$  applied, there is a net magnetization vector in the direction of  $H_0$ . The magnetic field  $h_1$ , produced by the RF driving current in the input loop causes the net magnetization vector to precess about the z-axis. The resulting RF magnetization component,  $m_y$ , induces a voltage into the output loop. At frequencies away from the ferrimagnetic resonant frequency,  $m_y$  and the voltage it induces are small, so input-to-output isolation is high. When the input current is at the ferrimagnetic resonant frequency,  $\phi$  and  $m_y$  are maximum. There is a large transfer of power from input to output, and insertion loss is low. Thus the filter center frequency is the ferrimagnetic resonant frequency and can be tuned by varying  $H_0$ . Commonly, the YIG sphere and RF structure are located between the poles of an electromagnet, and tuning is accomplished by furnishing a control current to the magnet coils.

To achieve improved selectivity and offband isolation, the YIG filter used in the preselector employs two YIG filter stages in series and in the same magnetic field. This filter was developed and is manufactured by the Watkins-Johnson Company.

<sup>1</sup> For a detailed treatment see, for instance, P. S. Carter, Jr., 'Magnetically Tunable Microwave Filters Using Single-crystal Yttrium-Iron-Garnet Resonators,' IRE Transactions on Microwave Theory and Techniques, Vol. MTT-9, No. 3, May 1961.

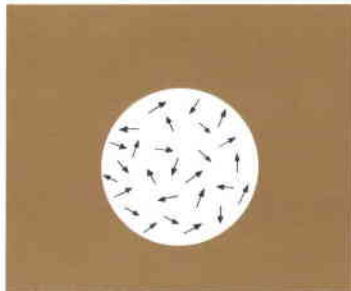

(a) Randomly oriented magnetic dipoles in the unmagnetized ferrite.

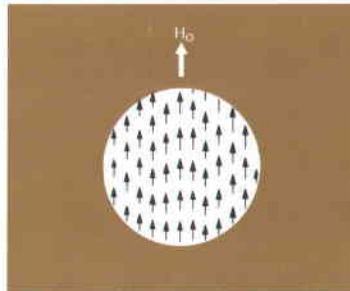

(b) Magnetic dipoles aligned under the influence of a magnetic field.

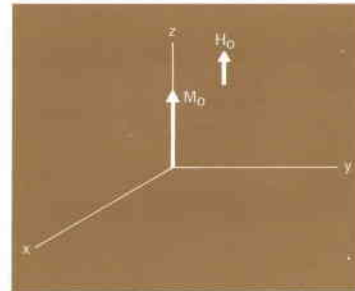

(c) An equivalent representation of (b) showing the combined effect of the aligned dipoles.

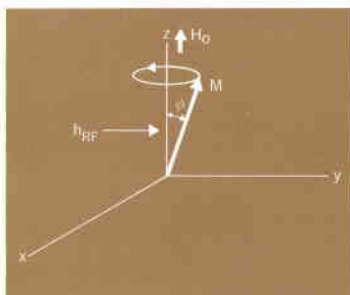

(d) Precession of the net magnetization vector due to RF magnetic excitation.

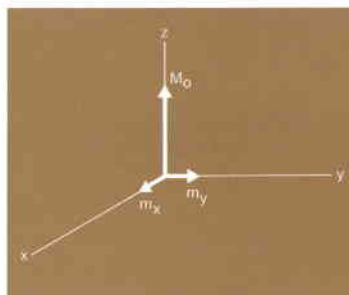

(e) Equivalent representation of precessing magnetization vector.

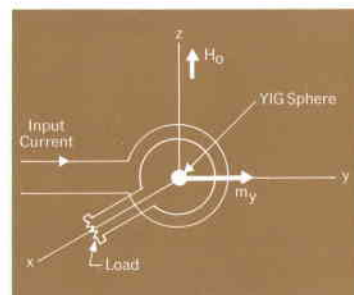

(f) Tuned bandpass filter consists of YIG sphere at center of two mutually orthogonal loops.

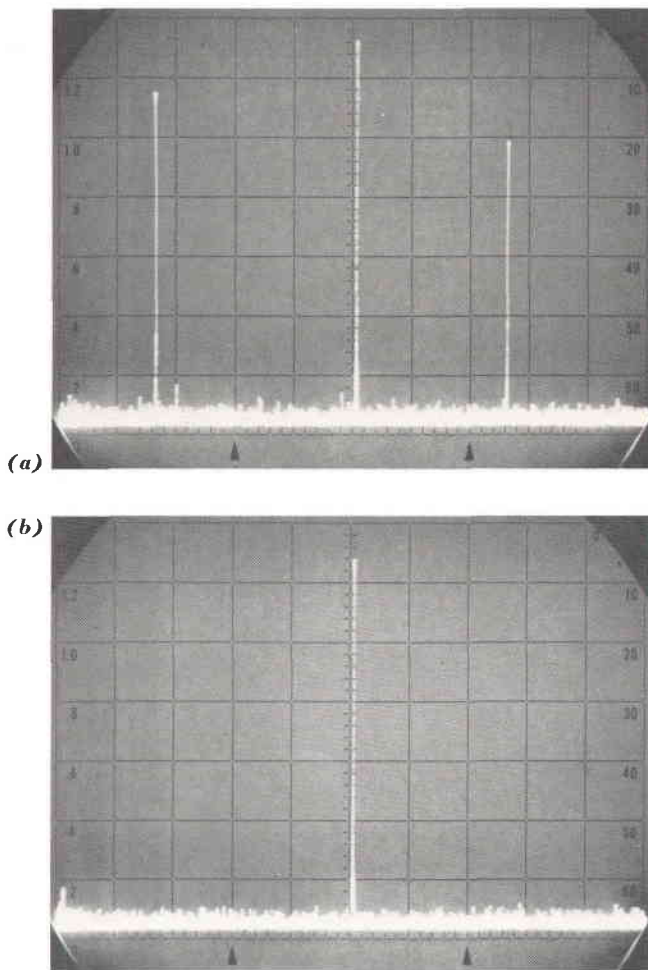

Fig. 3. (a) Spectrum-analyzer display for 5-GHz input signal, without preselection. Input signal produces responses by mixing with one or another LO harmonic when LO is tuned to 2.33, 3.00, and 3.50 GHz. (b) Model 8441A Preselector eliminates multiple responses by removing input when LO is tuned to 2.33 and 3.50 GHz.

### Multiple Responses

A single input signal above 4 GHz will produce responses for two or more different local-oscillator frequencies. A 5-GHz input, for example, will produce responses by mixing with one or another LO harmonic when the local oscillator is tuned to 2.33, 3.00, and 3.50 GHz. Like harmonic responses, these multiple responses can be eliminated by the preselector.

Fig. 3(a) shows the spectrum analyzer display resulting from a 5-GHz input signal when the local oscillator is sweeping over its entire range from 2 to 4 GHz, without preselection. The three multiple responses from left to right are the  $3^-$ ,  $1^+$ , and  $2^-$  mixing responses.

With preselection, any selected one of these responses is tracked by the YIG filter and the others rejected. Fig. 3(b) shows the resulting display when the  $1^+$  response is

preselected. The YIG filter sweeps from 4 to 6 GHz in synchronism with the local oscillator. When the local oscillator is at the frequencies required to produce the  $3^-$  and  $2^+$  responses from the 5-GHz signal, the filter is tuned away from 5 GHz, so these responses are rejected. Again, the amount of rejection is large except at the crossings of two response curves (indicated in Fig. 1).

Possible harmonic and multiple responses which can occur, even with preselection, when the tuning curves for two mixing modes intersect, can be avoided by switching to another mixing mode. By proper selection of analysis bands, multiple responses can be reduced by more than 38 dB throughout the range of 1.8 to 12.4 GHz.

### Spurious Responses

Spurious responses are harmonic and intermodulation distortion products generated by the nonlinear behavior of the analyzer's input mixer when it is driven by signals greater than  $-30$  dBm. Intermodulation distortion products are caused by the interaction of two or more strong input signals in the mixer.

The new preselector is effective in reducing spurious responses. Fig. 4 shows the analyzer displays both with and without preselection when two high-power signals are applied to the input mixer. Without preselection, harmonic and intermodulation distortion products make it difficult to find the desired signals. Preselection greatly simplifies the display.

With preselection, harmonics of either input signal are actually still generated in the mixer, but only while the preselector is tuned to the signal fundamental. At this time the local oscillator is tuned so that only the signal fundamental produces a 2-GHz IF signal; thus no response to the harmonics is produced. When the local oscillator is at such frequencies as to produce responses from signal harmonics, the preselector is tuned off the fundamental, so no harmonics are produced in the mixer. The only responses that appear on the display represent the true harmonic content of the signal.

Intermodulation distortion is also reduced by the preselector, if the strong signals causing it are separated by more than the YIG filter bandwidth (40 MHz). The preselector passes only one signal at a time to the mixer, and attenuates the other signal by an amount given by the selectivity characteristic, Fig. 5. For example, if the preselector is tuned to an 8-GHz signal, another signal 200 MHz lower in frequency will be attenuated 31 dB.

Using the preselector to reduce spurious responses increases the spectrum analyzer's spurious-free dynamic range — and, therefore, the analyzer's distortion-measur-

ing capability — by at least 30 dB. Normally, spurious responses are more than 50 dB down for -30 dBm input signals, but increase drastically for higher input levels. The preselector allows input signals up to one milliwatt to be applied without the multitude of unwanted responses that occur without preselection (Fig. 4). The resulting wide dynamic range may be used to advantage, for example, in observing the harmonic output of microwave signal sources. For a fundamental input level up to one milliwatt, harmonics may be observed at as low a level as spectrum-analyzer sensitivity will permit. Harmonics as much as 100 dB below the fundamental may be observed with assurance that they are not being generated in the mixer.

#### Observing Impulses

In analyzing the spectra of high voltage, narrow width pulses, such as those from impulse generators used for receiver calibration, preselection is a definite requirement. These pulses often have amplitudes of 100 V or more. If such a pulse were connected directly to the analyzer, its amplitude would be limited and its shape would be distorted by mixer saturation. This would change the spectrum being measured. The preselector, on the other hand, passes only the spectral lines within its bandpass, so the total power applied to the mixer at any time is extremely small, and no mixer saturation occurs.

#### Using the Preselector as a Tunable Filter

Although it is designed primarily as a preselector for the HP spectrum analyzer, the preselector can also be used independently as a tunable bandpass filter. The center frequency can be set anywhere between 1.8 GHz and 12.4 GHz. This can be done manually, using the calibrated front-panel control, or remotely, by means of a control voltage. There is also an internal sweep generator which can sweep the filter over its entire frequency range or any portion of it. In this sweeping mode of operation the preselector, in conjunction with a broadband detector and a sensitive oscilloscope, becomes a low-sensitivity but remarkably wideband spectrum analyzer (see Fig. 6).

#### Variable-Persistence Display Unit

Variable persistence, already in use on some HP oscilloscopes,<sup>1</sup> is now available in a new display unit for the HP spectrum analyzer (top instrument in photograph, Fig. 2). Designated Model 852A, the new display unit is similar to the standard display unit<sup>2</sup> except for the variable-persistence CRT and associated circuitry.

<sup>1</sup> R. H. Kolar, 'Variable persistence increases oscilloscope's versatility,' *Electronics*, November 29, 1965.  
<sup>2</sup> H. L. Halverson, 'A New Microwave Spectrum Analyzer,' *Hewlett-Packard Journal*, Vol. 15, No. 12, August 1964.

The persistence of the CRT in the new display unit can be varied between approximately 0.2 second and more than one minute. There is also a storage mode, in which a trace can be stored for more than an hour. With the instrument turned off, the trace can be stored for a day or more.

Unlike an oscilloscope, which would probably be operated with short persistence most of the time and switched to variable-persistence only for special applications, a spectrum analyzer display is most readable when it is operated in a variable-persistence mode. For all but the fastest spectrum-analyzer sweeps, the trace flickers noticeably with normal-persistence phosphors. Yet many routine applications call for slow sweep rates. For example, it is necessary to use a narrow IF bandwidth for better resolution or sensitivity, and this requires a slow sweep rate, since narrow-band filters respond slowly to

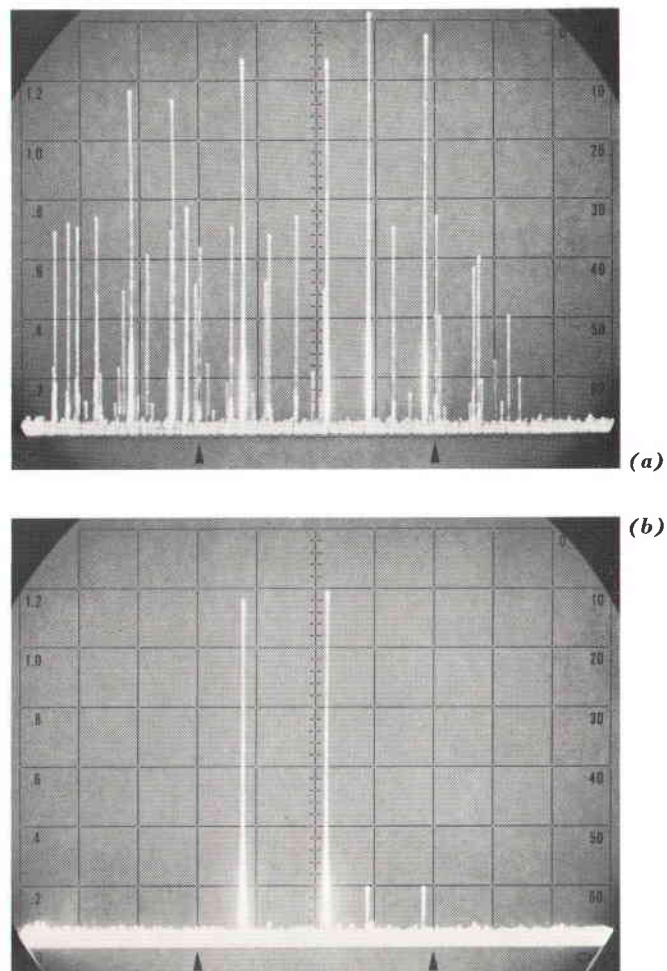

Fig. 4. (a) Without preselection, spectrum-analyzer display for strong (about 0 dBm) input signals at 4.9 and 5.1 GHz is complicated by intermodulation products and multiple responses. (b) Model 8441A Preselector reduces multiple responses and distortion products.

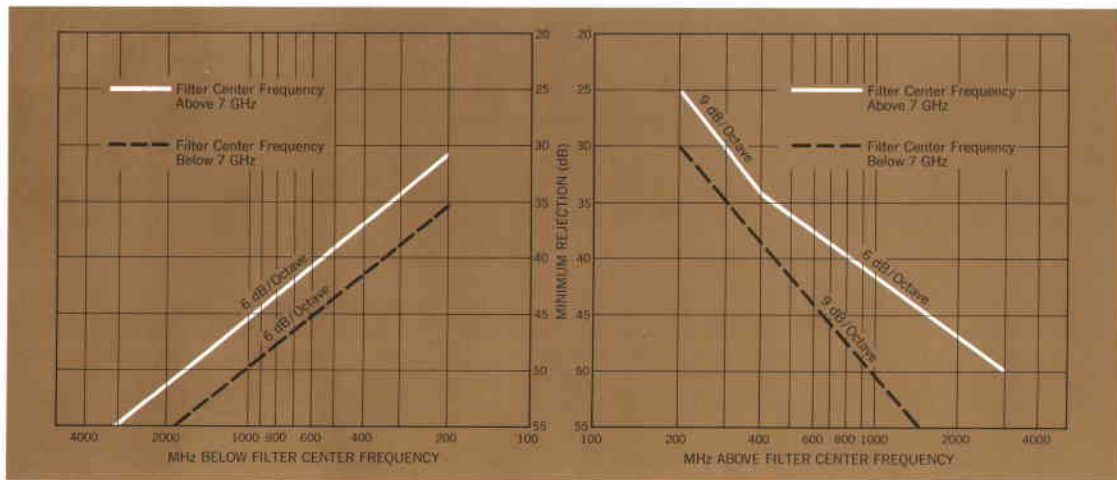

Fig. 5. Selectivity characteristic of Model 8441A Preselector.

suddenly applied input signals; if a signal sweeps past too rapidly, the IF filter's response will be incomplete, and a small signal may be missed entirely.<sup>3</sup> Flicker can be reduced by confining the sweep to a narrow frequency range, but this is also undesirable in many applications. Variable persistence makes slow sweep speeds usable without flicker. Reduction of the spectrum width can be avoided, and there is no need to resort to photographic techniques.

#### Difficult Measurements Made Easy

Variable persistence makes it possible to do things with a spectrum analyzer that would be difficult or impossible with normal persistence.

With normal persistence, at the faster sweep rates, a pulsed RF signal which has a repetition rate of 500 Hz or less appears on the analyzer's display as random lines.

<sup>3</sup> Rule of thumb: if BW is the 3-dB bandwidth of the IF filters, then the sweep rate should be less than  $(BW)^2$  Hz/second.

This type of pulse is commonly found in radar spectrum measurements. The reason for the apparent randomness is that a line will appear on the display only when an RF pulse occurs. The maximum number of lines visible at any time will be the pulse repetition rate times the persistence of the CRT phosphor. With a pulse repetition rate of 500 Hz and a persistence of 0.1 second, 50 lines will be visible. At 50 Hz and 0.1 second, only five lines will be visible. Since the analyzer's sweep is not synchronized with the pulses, the entire spectrum will eventually be displayed, but only a few lines of it will be visible at any time.

With variable persistence, individual lines can be stored long enough for a complete pattern to form (Fig. 7). Complete patterns can be seen either for fast or for slow sweeps, whereas with normal persistence, a complete pulse spectrum can be seen only with a slow sweep, and then flicker becomes a problem.

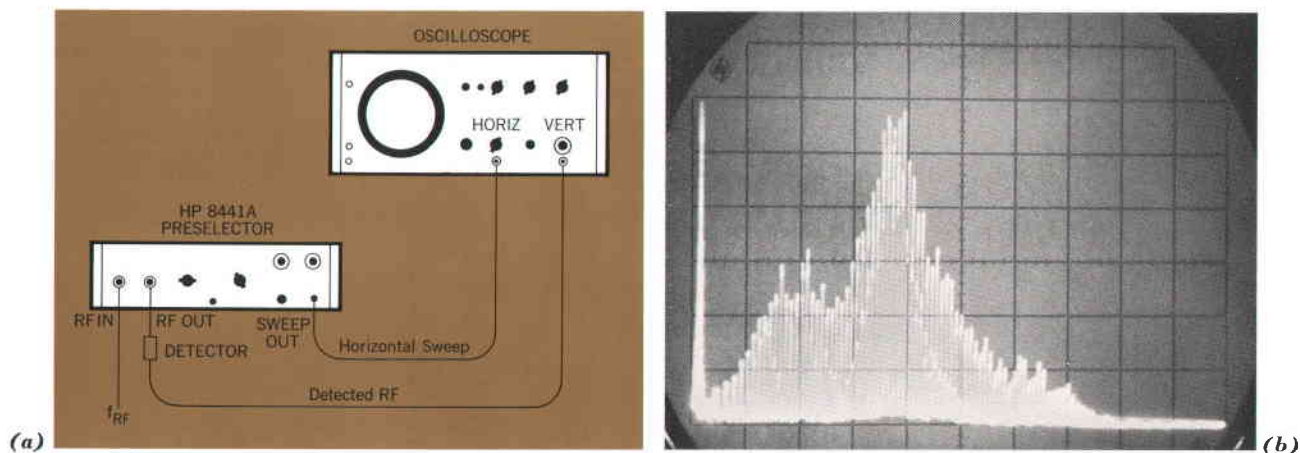

Fig. 6. (a) HP Model 8441A Preselector, with detector and oscilloscope, forms a low-sensitivity but very wideband spectrum analyzer. (b) Spectrum of high-power frequency comb obtained with spectrum analyzer setup (a). Sweep limits are 2 and 12 GHz.

Similar improvements in spectrum presentations can be obtained in noise measurements. The peak noise envelope becomes well defined after several sweeps have been stored (Fig. 8). This can be useful in measuring impulse noise, such as that encountered in RFI measurements. Impulse noise appears as faint spikes on a short-persistence CRT, but becomes a bright steady display when variable persistence is used. What's more, signals very near the noise level are easier to detect against the sharp envelope provided by variable persistence. Thus the effective sensitivity of the analyzer is increased.

Many RFI or spectrum-surveillance measurements are made more easily with variable persistence. For example, intermittent signals can be stored over periods of a minute or longer, permitting their frequencies and amplitudes to be measured.

Antenna pattern measurements can be made using storage, simply by reducing the analyzer's local-oscillator sweep to zero and scanning the CRT horizontally with an external signal proportional to antenna rotation. The stored display will then be a pattern of antenna gain or radiation versus rotation angle.

### Coaxial Input Mixer

Advantages of the new coaxial input mixer include the following.

- Extended coaxial range, 0.01 to 12.4 GHz. The upper limit was 10 GHz.
- Five to 15 dB more sensitivity over most of the coaxial range.\* This means lower-level signals can be measured.
- Flatter frequency response. Typical variations are now  $\pm 0.5$  dB for fundamental mixing and  $\pm 1.5$  dB for harmonic mixing, over any 2 GHz spectrum width. These variations include those caused by components, cables, and connectors preceding the mixer. Flatter frequency response means greater accuracy in comparing the levels of signals at different frequencies.
- Easily replaceable mixer diode. The mixer diode is located on the front panel and is readily changed by unscrewing a cap and unplugging the diode. The diode is a standard type (D-5282-C), not a specially selected one.

The design of the mixer is somewhat different from that of most microwave mixers. Not only is the mixer's frequency range very broad (0.01 to 12.4 GHz), but the intermediate frequency is 2 GHz, which is about two orders of magnitude higher than typical microwave-receiver IF's. The local-oscillator port is broadband from 2 to 4 GHz.

Another unusual feature of the mixer is that, to allow the mixer diode to be located on the front panel, the diode has to be separated from the mixer structure by a length of transmission line, instead of being integral to it. To get the IF current out of the diode and into the IF amplifier efficiently, a special two-cavity arrangement was developed. Fig. 9 is a schematic diagram of the mixer, and Fig. 10 is a photograph of its exterior.

### Mixer Operation

To cover the required input bandwidth of 0.01 to 12.4 GHz, the mixer takes

\* Sensitivity = signal power for which  $\frac{\text{signal power} + \text{noise power}}{\text{noise power}} = 2$ ; 10 kHz IF bandwidth.

Fig. 7. Spectrum of a CW signal pulse-modulated at 50 Hz. Envelope of spectrum would be poorly defined with normal persistence, but gradually becomes well defined with variable persistence of new HP Model 852A Spectrum Analyzer Display Unit.

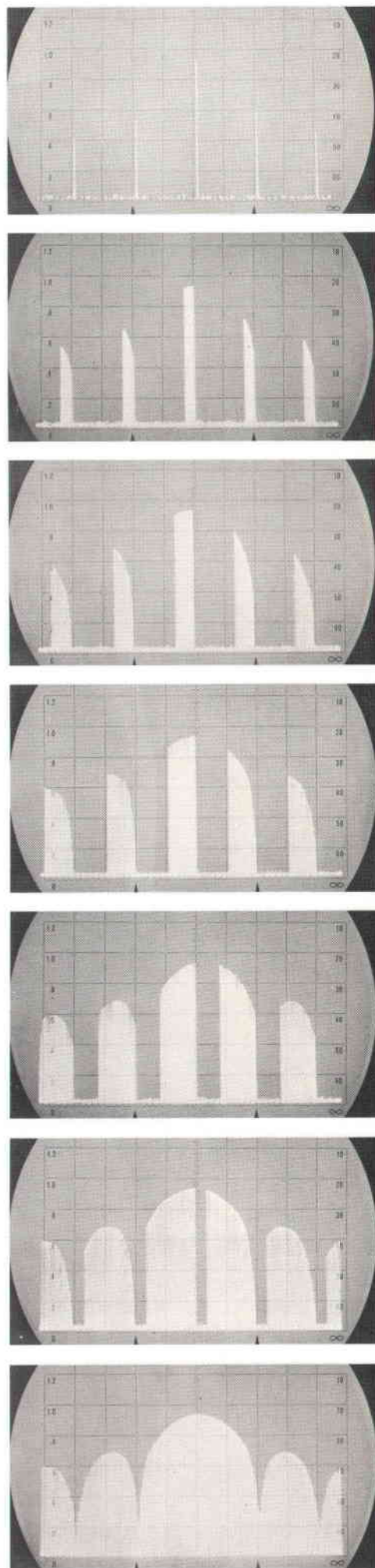

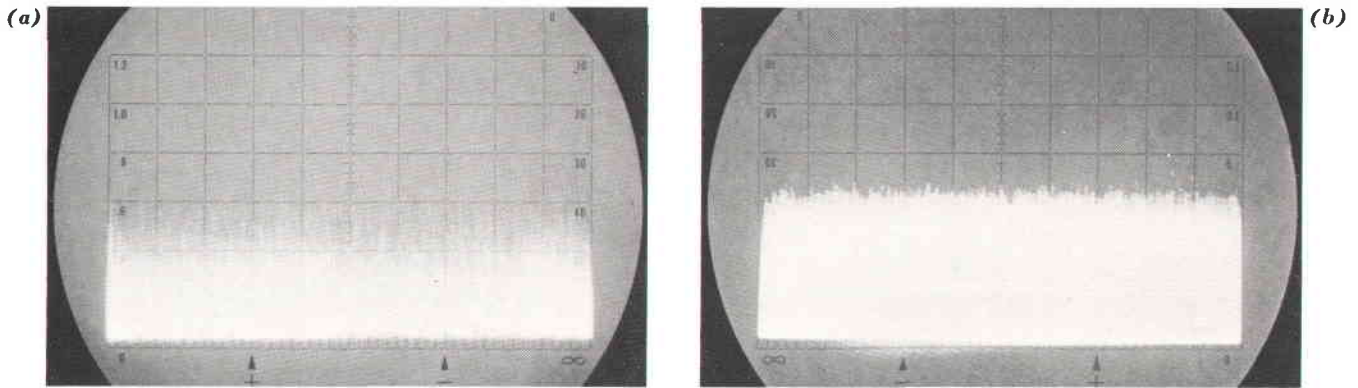

Fig. 8. Peak noise envelope, difficult to define with normal persistence (a), becomes well defined with longer persistence (b).

advantage of harmonic mixing. It converts input signals to 2 GHz according to the equation

$$f_s = nf_{LO} \pm 2 \text{ GHz}$$

where  $f_s$  is the input-signal frequency,  $f_{LO}$  is 2 to 4 GHz, and  $n$  is 1, 2, or 3.

Operation of the mixer in the fundamental mixing

mode ( $n = 1$ ) can be shown best by an example. Assume that the local oscillator is tuned to 3 GHz. The directional coupler in Fig. 9 couples some of the 3-GHz power into the transmission line which leads to the diode. This signal causes the diode to switch on and off at the local-oscillator frequency.

### PARTIAL SPECIFICATIONS

#### HP Model 8441A Preselector

CHARACTERISTICS AS A PRESELECTOR FOR THE 851B/8551B (or 852A/8551B) SPECTRUM ANALYZER  
(May also be used with the 851A/8551A Spectrum Analyzer; a slight modification to the 8551A is required.)

**FREQUENCY RANGE:** 1.8 to 12.4 GHz. Input connector, Type N female.

**BANDWIDTH (3dB):** 20 to 70 MHz.

**INSERTION LOSS:** Insertion loss in the passband is less than 5 dB; minimum VSWR in the passband is less than 2:1. The filter reflects applied signals at frequencies other than the passband, so the VSWR is very high outside the passband.

**LIMITING LEVEL:** (Maximum input level for <2 dB signal compression)  
-20 dBm, 1.8 GHz to 2 GHz.  
+10 dBm, 2 GHz to 12.4 GHz.

**ABSOLUTE MAXIMUM INPUT LEVEL:** +30 dBm; 8551 Input Attenuator must be set to keep power to analyzer input mixer below 0 dBm to prevent damage to the mixer.

**UNDESIRE RESPONSE REDUCTION:** (Reduction of responses of the 8551 to harmonic mixing modes other than the one preselected.) At least 35 dB.

#### CONTRIBUTION TO 8551B FREQUENCY RESPONSE:

Preselector Harmonic Mixing Mode	Addition to 8551B Variation*
1-; 200 MHz IF	±2.5 dB over 2 GHz range
1+; 2 GHz IF	±2.5 dB over 2 GHz range
2-; 2 GHz IF	±3.5 dB over 2 GHz range**
3+; 2 GHz IF	±4.5 dB over 2 GHz range

\* 8551 Input Attenuator setting 10 dB; 8441A Peaking control adjusted at center of 2 GHz swept range.  
\*\* Applies to 8551B's with serial number 550-00283 and above; slightly higher on earlier models.

**CONNECTIONS TO 851B/8551B:**  
851B Horizontal Output, BNC female.  
8551B Preselector Drive Output, BNC female.  
8551B RF Input, Type N female.

CHARACTERISTICS AS A VOLTAGE-TUNABLE BANDPASS FILTER

**INTERNAL SWEEP:** Center frequency continuously variable from 1.8 GHz to 12.4 GHz.

**WIDTH:** Continuously variable from 0 to 10 GHz about center frequency. (Frequency extremes cannot exceed 1.8 GHz to 12.4 GHz.)  
**REPETITION RATE:** 60 Hz.

**EXTERNAL SWEEP:**  
**CENTER FREQUENCY** (for external sweep input level of zero volts): 1.8 GHz to 12.4 GHz continuously variable. Filter can be manually tuned from 1.8 GHz to 12.4 GHz.  
**PRICE: Model 8441A, \$2,950.00**

#### HP Model 852A Spectrum Analyzer Display Section

(When connected to 8551B RF Section)

#### DISPLAY CHARACTERISTICS

VERTICAL DISPLAY (7 Div full scale deflection):

Mode	Scale Factor	Accuracy**
LINEAR	Relative Voltage/Div	±3% full scale
SQUARE	Relative Power/Div	±5% full scale*
LOGARITHMIC	10 dB/Div calibrated over 0 to 60 dB on CRT Display	< ±0.2 dB/dB but not more than +2 dB over full calibrated 60 dB CRT display range*

\* Except pulse spectra on 1 MHz IF bandwidth.  
\*\* 0 to 40°C.

#### CATHODE-RAY TUBE:

TYPE: Post-accelerator storage tube, 7300-volt accelerating potential; aluminumized P31 phosphor; etched safety glass face plate reduces glare.  
GRATICULE: 7 × 10 divisions (approximately 5.9 × 8.5 cm) parallax-free internal graticule; 5 subdivisions per major division on major horizontal and vertical axes.  
WARRANTY: CRT specifications (persistence, brightness, storage time) warranted for one year.

#### PERSISTENCE:

SHORT: Less than 0.2 s.

#### VARIABLE:

Normal writing rate mode: continuously variable from less than 0.2 s to more than 1 min (typically to 2 or 3 min).  
Max. writing rate mode: typically variable from 0.2 to 15 s.

ERASE: manual; erasure takes approximately 0.5 s; CRT ready to record immediately after erasure.

BRIGHTNESS: Greater than 100 foot-lamberts in NORMAL or VIEW; typically 5 foot-lamberts in STORE.

#### STORAGE TIME:

	NORMAL Writing Rate Mode	MAX. Writing Rate Mode
STORE Mode (dim display)	≥1 hour	1 minute typical
VIEW Mode (bright display)	≥1 minute	10 seconds typical

CRT BASE LINE CLIPPER: Front panel control permits blanking of CRT trace baseline to allow more detailed analysis of low repetition rate signals.

PRICE: Model 852A, \$3,400.00

#### HP Model 8551A Spectrum Analyzer RF Section

(When connected to 851B or 852A Display Section)

#### COAXIAL INPUT CHARACTERISTICS

**FREQUENCY RANGE:** 10.1 MHz to 12.4 GHz. Input connector, type N female.

**SENSITIVITY**  $\left( \frac{\text{signal power} + \text{noise power}}{\text{noise power}} = 2; 10 \text{ kHz IF bandwidth} \right)$ :

10.1 MHz to 1.8 GHz	-100 dBm, fundamental mixing
1.8 to 4.2 GHz	-100 dBm, fundamental mixing (using 200 MHz 1st IF)
2.4 to 4 GHz	-92 dBm, second harmonic mixing
4 to 6 GHz	-100 dBm, fundamental mixing
6 to 8 GHz	-90 dBm, second harmonic mixing
8 to 10 GHz	-86 dBm, third harmonic mixing
10 to 12.4 GHz	-87 dBm, second harmonic mixing
10 to 12.4 GHz	-80 dBm, third harmonic mixing

With source stability better than 1 kHz, greater sensitivity can be achieved using narrower IF bandwidth.

**FREQUENCY RESPONSE:** (Includes mixer and RF attenuator response with attenuator setting ≥10 dB).

Frequency Range	Mixing Mode n*	IF	Rel. Gain (approx.)**	Flatness full range	Flatness 100 MHz
10.1 MHz to 1.8 GHz	1-	2 GHz	0 dB	±1 dB	±1 dB
1.8 to 4.2 GHz	1+	200 MHz	0 dB	±3.5 dB	±2.0 dB
2.4 to 4 GHz	2-	2 GHz	-6 dB	+2 dB	±1.5 dB
4 to 6 GHz	2+	2 GHz	0 dB	±1.5 dB	±1 dB
6 to 8 GHz	3-	2 GHz	-10 dB	+2 dB	±1.5 dB
8 to 10 GHz	3+	2 GHz	-14 dB	±2.5 dB	±1.5 dB
10 to 12.4 GHz	2+	2 GHz	-13 dB	±3.5 dB	±1.5 dB
10 to 12.4 GHz	3+	2 GHz	-10 dB	±5 dB	±3 dB

\* n = LO harmonic.

\*\* The relative displayed amplitudes of equal-amplitude input signals for various harmonic mixing modes.

**IMAGE SEPARATION:** 4 GHz (2 GHz First IF); 400 MHz separation when using 200 MHz IF).

**RESIDUAL RESPONSES** (no input signal): Less than -90 dBm referred to signal input on fundamental mixing (-85 dBm when LO is within 60 MHz of 2 or 4 GHz).

**MAXIMUM INPUT POWER** (for 1 dB signal compression):

Input Atten. Setting	Typical Max. Input (Peak or Average)
0 dB	-5 dBm
10 dB	+5 dBm
20 dB	+15 dBm
30 dB	+25 dBm
40 - 60 dB	+30 dBm

**MIXER DIODE:** Standard D-5282-C replaceable from the front panel.

PRICE: Model 8551B, \$7,550.00.

**MANUFACTURING DIVISION:** HP MICROWAVE DIVISION  
1501 Page Mill Road  
Palo Alto, California 94304

Now assume a smaller 1-GHz signal is applied to the input port. This signal propagates to the diode uninterrupted by the cavities because they are tuned to 2 GHz.

At the diode, the 1-GHz signal sees a large reflection coefficient switching from one phase to another as the diode is switched on and off by the local oscillator. In the ON state the diode looks like a small inductive reactance in series with some spreading resistance. In the OFF state it looks like a large capacitive reactance. The non-linear process which results from the 1-GHz signal meeting the phase-switching reflection coefficient produces currents at  $3 - 1 = 2$  GHz and  $3 + 1 = 4$  GHz. Waves at these frequencies travel back up the transmission line, to the left in Fig. 9.

The two cavities perform the task of taking the 2-GHz power off the main line and routing it to the IF amplifier. Cavity #2 is loaded by the 50  $\Omega$  input resistance of the IF amplifier via a coupling loop in the cavity. To 2-GHz signals, cavity #2 presents a resistance in series with the main line.

Cavity #1 is unloaded, so it is a virtual open circuit at 2 GHz. Cavity #1 is a quarter wavelength (at 2 GHz) from cavity #2, so the high impedance of cavity #1 is transformed into a short circuit just to the left of cavity #2. Looking left into cavity #2, therefore, 2-GHz IF signals see just the 50  $\Omega$  input resistance of the IF amplifier across the main line. Thus all of the IF power goes to the IF amplifier. This scheme routes the 2-GHz power traveling left from the diode to the IF amplifier with a loss of only 0.3 dB, and does it without perturbing the

main line at frequencies other than 2 GHz.

Cavity #1 also helps prevent 2-GHz input signals from going directly to the IF amplifier and causing the entire baseline of the display to lift. This cavity is a reflective trap at 2 GHz.

### Diode on Front Panel

The length of transmission line between the diode and the rest of the structure is inconsequential. Thus the diode can be placed on the front panel. Should too much power be applied at the input port, thereby destroying the diode, a new diode can be installed immediately and the instrument returned to service.

The local-oscillator signal in the HP spectrum analyzer is generated by a backward-wave oscillator that has large variations in its output power as it is swept from 2 to 4 GHz. These variations ordinarily would cause the bias on the mixer diode to vary, thereby causing the diode's conduction angle to vary. (The conduction angle is the portion of one LO cycle that the diode is on.) However, for the mixer to have a flat frequency response, the diode's conduction angle must be held constant.

For first- and third-harmonic mixing the desired conduction angle is  $180^\circ$ . To achieve this conduction angle it is necessary to keep the dc voltage across the diode very close to zero volts, regardless of diode current. What is needed is a dc return which acts as a near short circuit at low frequencies, and a near open circuit at frequencies between .01 and 12.4 GHz. The classical inductive dc return couldn't be used because it is virtually impossible

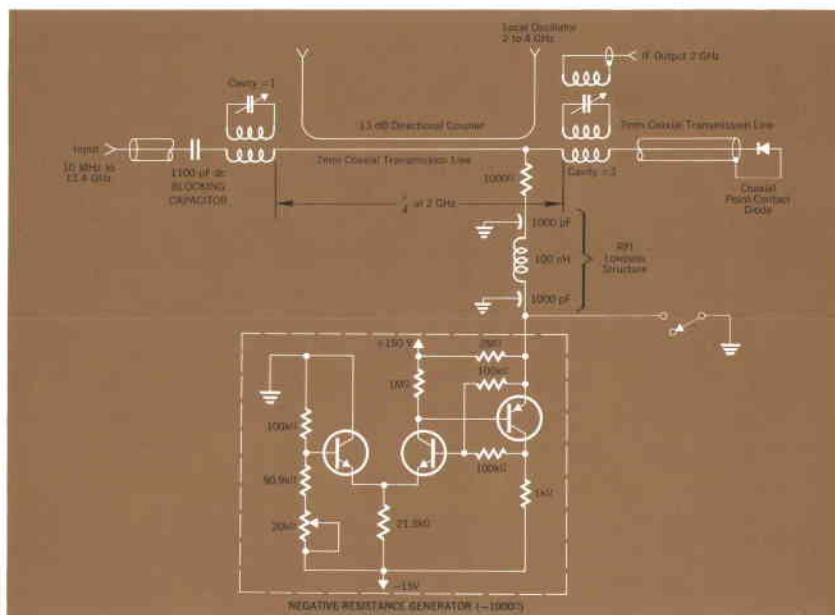

Fig. 9. Two-cavity design of new coaxial input mixer allows mixer diode to be located on front panel, instead of being integral to mixer structure.

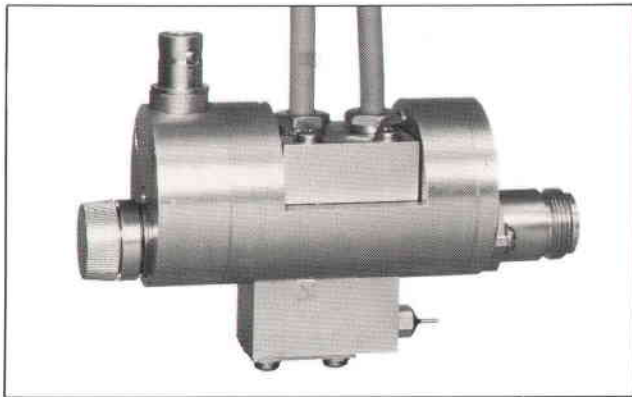

Fig. 10. Exterior view of new mixer.  
Diode is inside cap at left.

to build inductive dc returns which have three decades of bandwidth. The problem was solved by bridging the line with a low-capacitance  $1000 \Omega$  resistor, and by removing the resistor at the low frequencies at which the diode bias tends to vary (sweep frequencies and harmonics of sweep frequencies). The resistor is removed by means of a very simple three-transistor negative-resistance generator. When the current through the diode changes because of changing local-oscillator power, the voltage across the  $1000 \Omega$  resistor changes too. But the voltage across the negative resistance generator changes an equal and opposite amount, so the dc voltage across the diode remains close to zero.

When second-harmonic mixing is used, the  $-1000 \Omega$  generator is shorted out so that the dc return has a resistance of  $+1000 \Omega$ . This allows the diode to bias itself to a conduction angle of approximately  $90^\circ$ .

The mixer has a conversion loss of about 9 dB on fundamental mixing, 15 dB on second harmonic, and 22 dB on third harmonic.

#### Acknowledgments

The HP Model 8441A Preselector was designed under the direction of Harley L. Halverson and Roderick Carlsson. Mechanical design was by Edgar C. Hurd.

The initial design of the Model 852A Display Unit was done by Robert E. Jacobsen. Final design was done by Charles W. Cook.

Russell B. Riley provided many valuable suggestions during the design of the new mixer. John E. Nidecker did the product design of the mixer. 



#### John J. Dupre

Jack Dupre came to HP in 1964, after graduating from California State Polytechnic College with a BS degree in electronic engineering. He designed the 8441A Preselector, then turned to his present activity, developing microwave transistor oscillators.

In June, 1967 Jack received his MS degree in electrical engineering from Stanford University. He had attended

Stanford on the Honors Cooperative program while working at HP.

Jack is a member of IEEE. He is married and has two children.



#### Richard C. Keiter

Rit Keiter earned his BS degree in electrical engineering at the University of Colorado, graduating in 1965. He came to HP the same year.

At HP, Rit worked on the 431C Power Meter and the 8402B Power Meter Calibrator, and designed the new coaxial input mixer for the HP spectrum analyzer. Now a project engineer in the Microwave Laboratory, he is developing

microwave mixers and solid-state sources.

Rit is a member of Sigma Tau and Eta Kappa Nu. He has been attending Stanford University on the Honors Cooperative program, and will receive his MS degree next June. He is married, and he and his wife share an interest in flying.



#### John R. Page, Jr.

John Page received his BS degree in electrical engineering from Stanford University in 1959. He then entered the U. S. Navy and served from 1960 to 1961 as an officer on the aircraft carrier USS Coral Sea. Then it was back to Stanford, where he received his MS degree in electrical engineering in 1962.

In 1963 John joined the HP Microwave Division, having previously worked

two summers there. He helped design the 312A Wave Analyzer and the 8708A Synchronizer, and in 1965 assumed project responsibility for the 312A. He was also the project leader for the 852A Display Unit. At present, John is working on spectrum analyzer development, again as project leader.

John is married, has two children, and enjoys outdoor sports and photography.

# HP Archive

This vintage Hewlett-Packard document was  
preserved and distributed by

**[www.hparchive.com](http://www.hparchive.com)**

Please visit us on the web!

On-line curator: John Miles, KE5FX

[jmiles@pop.net](mailto:jmiles@pop.net)

