

# HEWLETT-PACKARD JOURNAL

Cover: TAPE RECORDER HEADS BEING  
ALIGNED UNDER MICROSCOPE: see page 2

See Also: CURRENT-SENSING RECORDER AMPLIFIER, page 8

WIDEBAND COAX WAVEMETERS, page 10

TESTING STEP-RECOVERY DIODES, page 13

SWEEP-FREQUENCY VSWR TO 18 GHz IN COAX, page 14

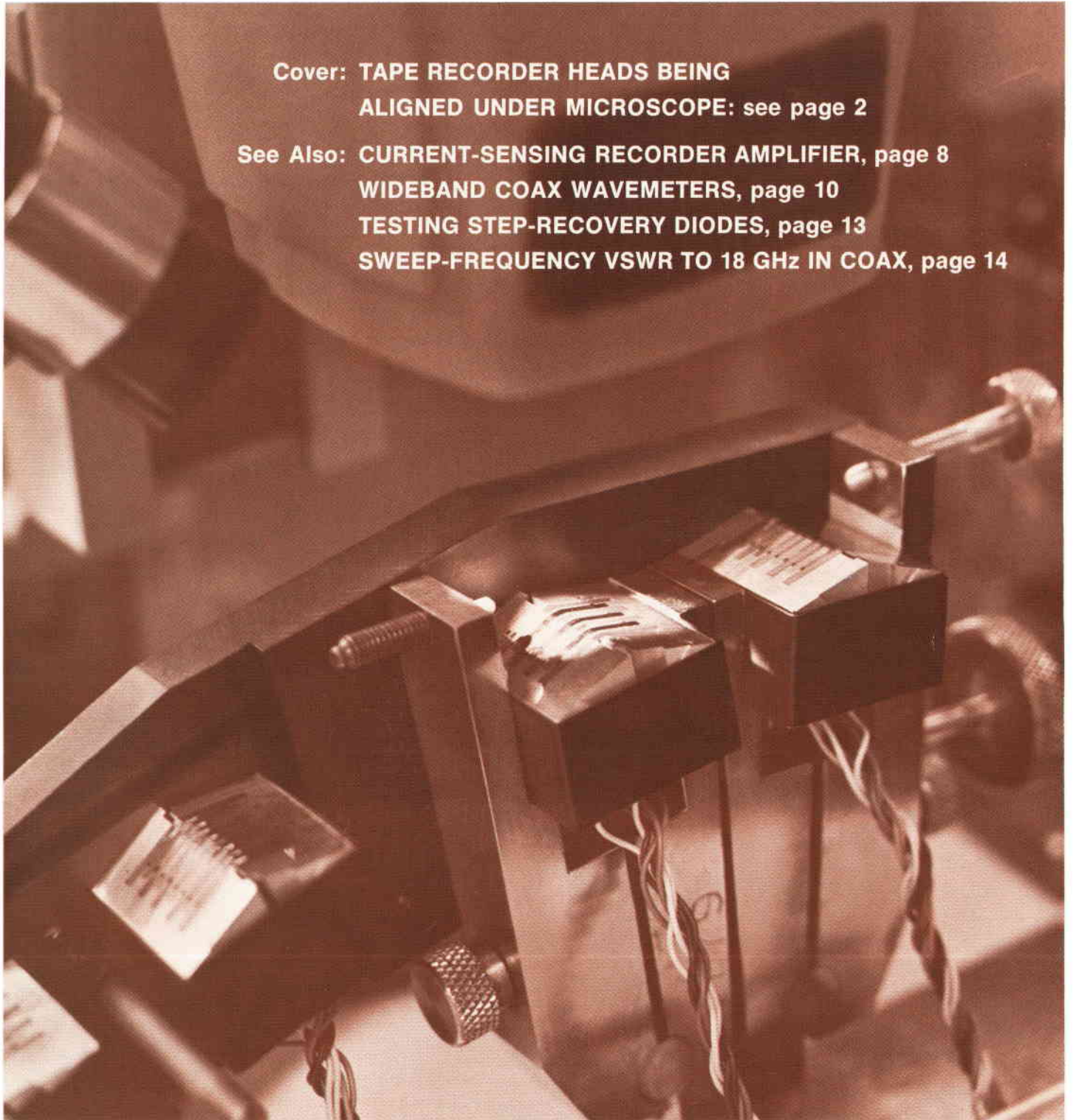

DECEMBER 1966

# A New High-Performance 1.5 MHz Tape Recorder

*A new instrumentation-quality tape recorder has been designed around a current-rather than voltage-sensing input amplifier. Decreased noise and wider bandwidth are direct benefits of this approach.*

**I**NSTRUMENTATION TAPE RECORDERS require highly-sophisticated mechanisms and electronics to maintain precise tape speed, and to record and reproduce signals without excessive distortion and noise over wide bandwidths. Complex tape transport mechanisms are costly. Signal circuitry designed to minimize distortion and noise in critical instrumentation applications often becomes complicated and generally includes a large number of components.

A completely different approach to a magnetic tape system has been used in a new 1.5 MHz tape recording system, Fig. 1. The reproduce head feeds a low-impedance preamplifier which senses current output of the reproduce heads instead of voltage. This scheme improves the noise performance of the system, permits greater flexibility of design and reduces the deleterious effects of head wear. Amplifiers designed for this system use large amounts of feedback, resulting in low distortion with less than half the number of transistors used in previous systems. A simplified precision tape trans-



*Fig. 1. Low-impedance preamplifiers used in the new -hp- 3950 Series Tape Recorders sense current output of the reproduce heads instead of voltage. The result is a signal-to-noise ratio of greater than 30 dB from 400 Hz to 1.5 MHz, and a greater design flexibility permitting lower system cost, while maintaining high performance. The system is available with up to fourteen record and reproduce channels as shown.*

port eliminates the need for servo speed controls. All of these features combine to provide high performance at relatively low cost.

Because the cost of this 1.5 MHz system is comparable to the cost of 100 kHz systems, use of the machine can be general; that is, for wide-band 1.5 MHz, medium bandwidth 300 kHz, or narrow-band 100 kHz instrumentation applications. While the cost of this class of recorder has been reduced by about 60%, its performance and ease of use have improved.

The machine is available in the two most common configurations used for analog recording. One is Direct, which in principle is the same as ordinary home recording, and the other is FM. In the Direct Mode, the machine has a range of bandwidths from 1.5 MHz for 15 minutes playing time to 23.5 kHz for 16 hours, and at any octave in between using standard 14-inch reels.

In the FM Mode, the bandwidth for a given playing time is about 25% of that of the corresponding Direct machine, but FM recording eliminates tape-caused dropouts and also has the capability of passing dc. Fig. 2 shows the various bandwidths and recording times of the new recorder. Signal-to-noise ratio at a bandwidth of 1.5 MHz is greater than 30 dB at low (1%) distortion levels.

## RECORD CIRCUITRY

The 1.5 MHz bandwidth is achieved in the Direct record mode. An input signal is fed through an input attenua-

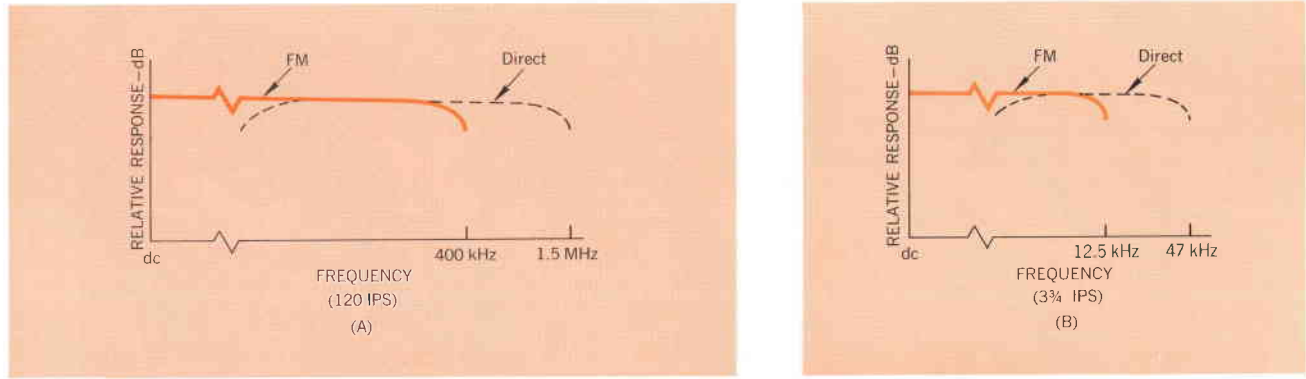

Fig. 2. Frequency response in the FM mode and Direct mode at a tape speed of 120 ips (a) and 3 $\frac{3}{4}$  ips (b). In the FM mode, bandwidth is exchanged for dc response and freedom from dropouts.

tor to the record amplifier, Fig. 3. The output of the record amplifier goes to a flux equalizing filter which boosts the high-frequency end of the band, compensating for head-caused high-frequency losses. Output from the flux-equalizing filter is mixed linearly with the bias. Then the combined signal is fed to the record head.

Bias is generated by a push-pull oscillator followed by a balanced amplifier, providing a 7 MHz bias signal to each direct-record amplifier. An AGC loop holds the bias level to within  $\frac{1}{2}$  dB regardless of load.

It is important that the bias current be substantially free of even harmonics. They should be well below 0.1% of the fundamental, since the bias amplitude is close to the saturation level of the tape. Consequently, even harmonic distortion in the bias causes dc magnetization on the tape which in turn causes even harmonic distortion of the re-

corded (information) signal. The push-pull bias amplifier reduces even harmonic distortion to well below 0.1%. In addition, the bias is fed through a bandpass filter before mixing with the signal to be recorded.

All of the record electronics components are contained in a single module accessible from the front. Cables to the heads are terminated in their characteristic impedance. Thus it is not necessary to mount the bias driver adjacent to the heads, since the cable capacitance does not load the bias source.

The meter amplifier has one stage of amplification. A two-position switch permits monitoring signal level or checking bias.

Direct Record modules and FM Re-

cord modules may be used in different channels at the same time in the system.

#### REPRODUCE CIRCUITRY

A reproduce current preamplifier for each channel is located on the transport chassis behind the heads. These preamplifiers provide a stable, low-noise, low-distortion signal to the reproduce amplifiers. The reproduce amplifier module, Fig. 4, contains an amplitude equalizer followed by a voltage amplifier, then a gain control followed by an amplitude and phase equalizer and finally a power amplifier.

Current gain of the system is about 150,000 at short wavelengths (wavelength equals tape speed divided by recorded frequency) of about 80 microin-

#### COVER

Record heads of a complete 1.5 MHz magnetic head assembly are shown mounted in a fixture preparatory to aligning gap-to-gap spacing according to IRIG standards. In this process, a mask is placed over the heads and the gaps are viewed through a narrow slit with the aid of a microscope. After gap spacing is adjusted, the heads are fixed to the baseplate.

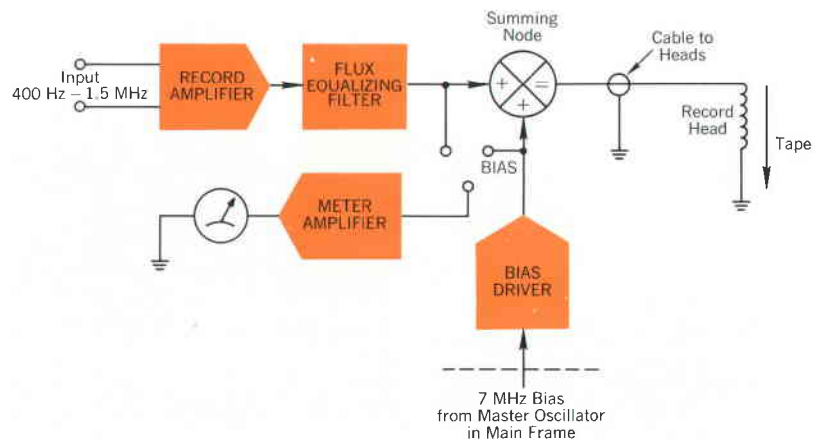

Fig. 3. Record circuitry includes a flux equalizing filter to compensate for high-frequency losses in the record head. One bias oscillator is used for each set of seven channels in the system.

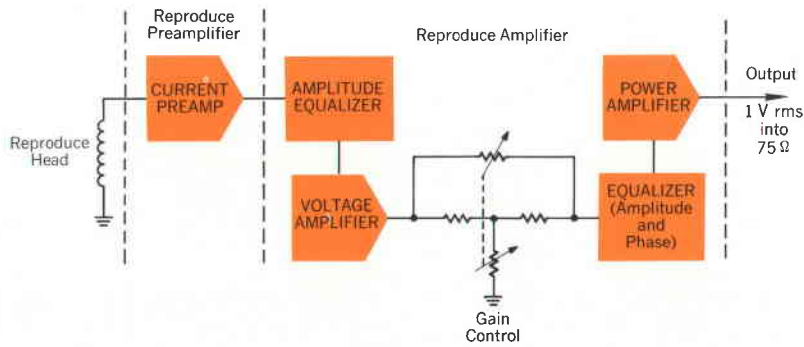

Fig. 4. Reproduce amplifiers use a large amount of feedback around all the transistors to provide low distortion with a minimum number of components.

ches at 1.5 MHz. The total noise from the tape, head and the electronics (referred to 1.5 MHz) is about 4 nanoamperes at the input of the preamplifier.

Equalization is required to compensate for about a 26 dB roll-off at high frequencies. This roll-off results from lessened head-tape efficiency at short

wavelengths. Because the amplitude equalizer causes phase error, phase equalization is provided. An example of the losses in the record/reproduce system and the equalization required is shown in Fig. 5.

#### CURRENT PREAMPLIFIER

One of the important features of the

direct reproduce system is the current preamplifier.<sup>1</sup> Because the preamplifier senses short-circuit current of the reproduce head rather than open circuit voltage (as in most other systems), reasonable lengths of head-to-preamplifier cable can be used without unpredictable variations occurring in the passband. Such variations are caused by resonance between the inductive head and the connecting cable-capacitance. The low impedance of this preamplifier shorts out that capacitance with respect to the signal current and avoids the unwanted unpredictable peaking in the passband.

Preamplifier signal-to-noise ratio is maximum only over a specific source impedance range, because a transistor amplifier exhibits minimum noise only when its source is a particular value.<sup>2</sup> Where an RL source is seen by the preamplifier, this low noise figure is achieved over a relatively narrow frequency range. In this system, the cable

## MAGNETIC TAPE RECORDING AND REPRODUCING

The most common method of recording is called 'Direct'. Very wide bandwidths can be achieved in the Direct mode. In the -hp- Model 3950 system, a bandwidth of 1.5 MHz makes possible wideband applications including transient studies, shock wave studies, and predetection recording. High-frequency pulses can be recorded at the high recorder speeds, then played back at a slower speed for recording of a permanent visual record on an oscillograph.

The recording head is an electromagnet with a minute gap in the core at the point of contact with the magnetic tape. Magnetic tape has a coating of magnetic material which is initially demagnetized. The tape, as it passes over the gap, acts as a magnetic shunt. The signal to be recorded is first mixed with a high-frequency bias current before being applied to the record head winding. This places the signal on a linear portion of the magnetic tape coating B-H curve. As the tape leaves the trailing edge of the gap during recording, the tape coating is left permanently magnetized in a manner depending upon the frequency and intensity of the input signal.

The reproduce or playback head is similar to the record head except for a smaller gap width. When magnetized particles are

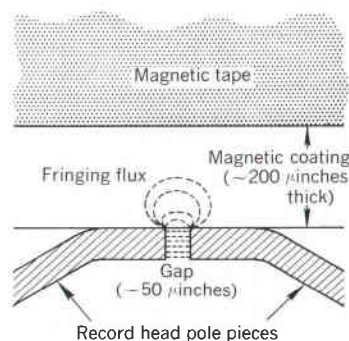

Cross-section of the record process. The iringing flux penetrates the coating and, as the tape moves across the gap, leaves a series of magnetized segments representing the recorded signal.

shunted across its gap, a magnetic flux is established in the core. As the tape moves, the flux induces a current in the reproduce head winding proportional to the intensity of magnetization of the tape particles. The playback current, equalized for losses in the various components of the system, re-creates the original signal.

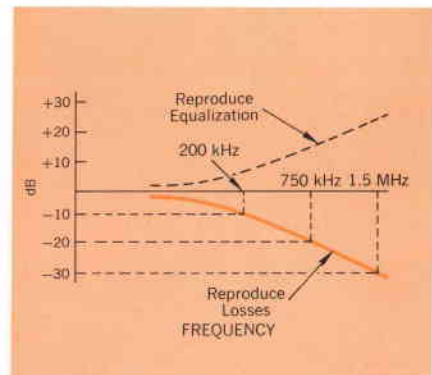

Fig. 5. Losses in the record/reproduce process must be made up by equalization in the reproduce system.

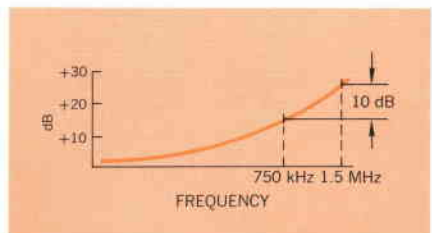

Fig. 6. Typical reproduce system response illustrates how distortion harmonics are accentuated relative to their fundamental.

between the head and the preamplifier adds capacitance to the head resistance and inductance, and thus shapes the resonance curve so that the preamplifier sees the optimum source impedance over a wider frequency range. This resonance has no effect on the signal response. It only causes the noise response of the system to dip over this wider range. Thus, cable capacitance is turned to advantage.

#### LOW DISTORTION AMPLIFIERS

The typical reproduce equalization curve, Fig. 6, shows that if a signal is distorted prior to passing through the equalization, then the distortion components are accentuated by the equalization. In Fig. 6, a 750 kHz signal is amplified only about one-third as much as a 1.5 MHz signal. Therefore, the fundamental of a 750-kHz signal with second harmonic distortion (that is with an undesired 1.5 MHz component) will be amplified by unity, but the second harmonic will be amplified by a factor of 3. Thus 1% distortion at the front end of the reproduce amplifier becomes 3% distortion at the output.

In this tape system at the standard record and reproduce levels, reproduce amplifier distortion, including the excess magnification due to the equalizer, is typically below 0.1%. This low distortion is achieved through the use of three- and four-transistor amplifiers with feedback around the several transistors. A bonus of this design is that only fifteen transistors are required per channel including metering, instead of the usual 30 to 60 transistors. Ten of these transistors are in the reproduce electronics.

#### TAPE TRANSPORT

The paramount objective of any transport is to move the tape at a uniform speed, both on an average and on an instantaneous basis past the heads. Otherwise, time displacement error, noise, level shifts and generally erratic recording and reproduction will result.

Ruggedness and high performance have been achieved by simplifying the tape transport, Fig. 7. Highly-damped synchronous motors drive the capstan, eliminating the need for complex servo systems. A total of three mechanically-

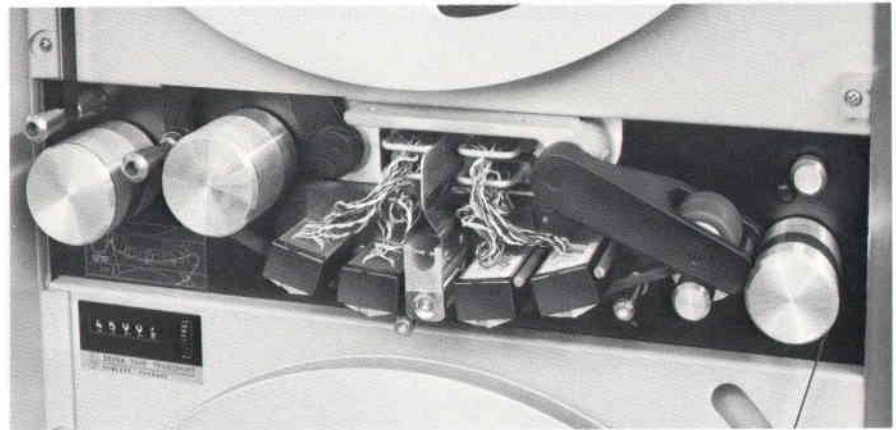

Fig. 7. A simple open loop tape drive permits easy threading of the tape.

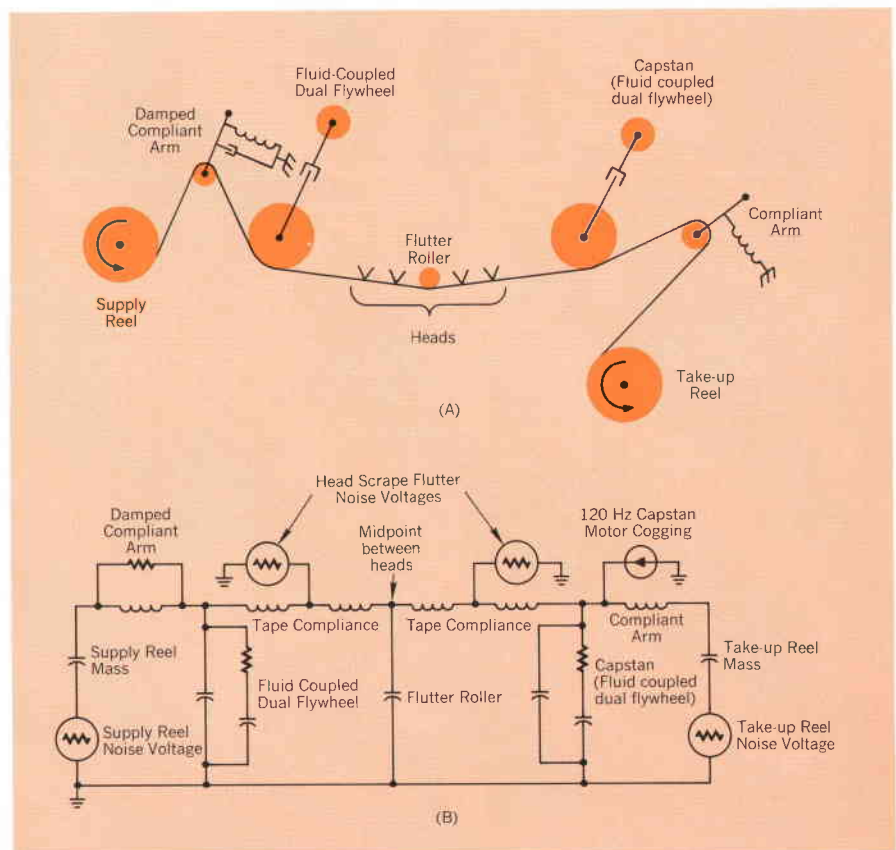

Fig. 8. Prime noise sources and filter elements of the tape drive (a) are shown in its electrical analog (b).

coupled synchronous motors are in the transport, each capable of two speeds. Thus, six speeds are available. Normally, standard 60 Hz power is sufficiently accurate for ordinary operation. Otherwise, a 60 Hz precision power supply should be used.

A novel system of mechanical braking is used which maintains constant braking tension on the reels regardless

of wear of the braking materials or the coefficient of friction. Motor torque is controlled to insure constant tension in all modes of operation, insuring an even tape pack on both the supply and take-up reels, and constant pressure against the head.

Because power dissipation in the transport has been reduced by eliminating the need for complex servo sys-

## SQUARE WAVE RESPONSE OF THE -hp- MODEL 3950 MAGNETIC TAPE RECORDING SYSTEM

Phase performance of a linear system may be checked by applying a low-repetition rate square wave to the input and analyzing the output waveform. A square pulse passed through a perfect low-pass filter (flat response, abrupt cutoff and perfectly linear phase) will emerge with perfect left-right symmetry, but with leading and trailing edge 'ears.'

<sup>1</sup> Mischa Schwartz, *Information Transmission, Modulation, and Noise*, McGraw-Hill, 1959, pp. 41-48.

Performance of the new tape recorder is shown in the accompanying oscillograms. A 100 kHz square wave was applied at the 120 ips speed (1.5 MHz bandwidth). The output waveform, left, shows good phase linearity as compared to the waveform, right, reproduced without phase equalization.

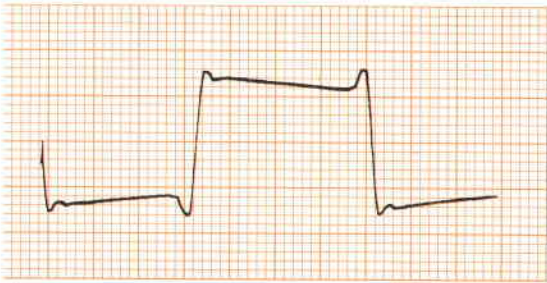

tems, a blower need not be used. Air is not drawn through the machine, thus avoiding the possibility of airborne abrasives damaging internal components.

### TAPE PATH

Low-frequency perturbations of large amplitude are generally introduced by the supply and take-up reels, because of unavoidable eccentricities in the packing of tape on a reel. Smaller high-frequency perturbations are caused by all elements of the tape path, including the heads, as the tape scrapes over them, Fig. 8 (a). These tape perturbations are called flutter. An electrical analog of the tape path may be derived by forming the analogy that the tape velocity is analogous to voltage; that tape tension is analogous to current; that fluid viscosity is analogous to resistance; that mass is analogous to capacitance; and that spring constant is analogous to inductance.

This electrical analog, Fig. 8(b), shows that the problem of removing flutter is similar to that of filtering ripple from a power supply. Two power supplies (reels) are in parallel, and the ripple is filtered at the center node between them which corresponds to the center point between the heads. Vari-

ous circuit elements provide low-pass filtering to permit uniform tape velocity past the heads (voltage at center node), shielding the heads from the high amplitude reel-induced 'noise'. The fluid-coupled dual flywheels bypass the ripple to 'ground', and the compliant arms block perturbations even before they reach the flywheels. The flutter roller between the heads shorts the high-frequency perturbations to 'ground'. Resistance elements in the system—dashpots and fluid coupling—keep Q low for best filter response.

### PACKAGING

Because a multichannel tape recorder is in reality several distinct instruments, it is necessary to insure that all channels are operating properly and that all of the controls are easily accessible to the operator from the front panel. A meter in each channel used to monitor record level also doubles as a bias presence indicator. Recording without bias is nearly equivalent to not recording at all. Therefore, with an indication of bias presence and the record signal adjusted to the proper level, the operator is assured that the record channel is in operation. A single meter in the reproduce system can be switched to each

channel to check the reproduced signal.

All of the electronics modules have accessible front panel controls and can be removed from the front. The tape

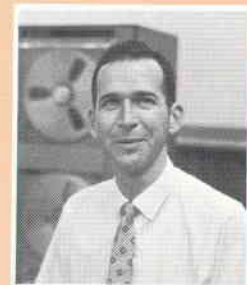

GERALD L. AINSWORTH

Jerry Ainsworth has been working with magnetic recording systems since 1961. He has worked as project engineer for computer tape development and as lead electrical engineer for a satellite-borne tape recorder. Since he joined -hp- in June, 1964, he has designed the electronic system of the -hp- 3950 and has had primary responsibility for the engineering of the broadband tape recorder systems. He received his BS degree from Stanford in 1955 in EE. After spending three years as a Gunnery Officer aboard a destroyer, he returned to Stanford on the Honors Co-op Program and earned his MSEE degree in January, 1961. Jerry is a member of IEEE and Tau Beta Pi.



(a)

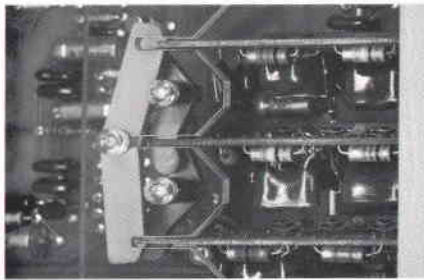

(b)

Fig. 9. Each record and reproduce amplifier accepts three plug-ins for equalizer switching (a). Equalizers are mechanically switched into the circuit by merely pressing them from the front panel. A three way teeter-totter mechanism (b) disconnects any other equalizer automatically when one is pressed.

transport mechanism also is removable from the front. All of the amplifiers are on printed-circuit boards and are connected to the rest of the system by printed-circuit mother boards, thus insuring that all channel parasitics are equal, do not vary, and are the same for any machine.

Each reproduce amplifier accepts three equalizer plug-ins for any three of the six standard tape speeds, Fig. 9(a). Rapid speed changes are made possible by a three-way teeter-totter mechanism. When the push-bar on one equalizer is depressed, the previously-connected equalizer is automatically disconnected, Fig. 9(b). The plug-in equalizers are replaceable from the front panel without removing the amplifier module. Connections are made through high-pressure sliding contacts ensuring dependable switching, even in a hostile environment.

#### TEST SIGNALS

Test inputs are located on the front of the record main frame. To apply a test signal to a track, the signal is con-

nected to the test jack and the appropriate button pushed. The normal data signal input is removed and the test signal inserted in the record amplifier. The output test points from the reproduce amplifiers are similarly available at the front of the system. Therefore, it is possible to check all channels from the front panel.

#### ACKNOWLEDGMENTS

I would like to thank Wallace Overton who made the measurements and tests upon which the electronic design for this machine was based, Robert DeVries who packaged the electronics and Walter Selsted, the group manager, who made textbook design interesting.

Magnetic heads for the -hp- 3950 Magnetic Tape Systems are manufactured by the -hp- PAECO Division. Unique manufacturing processes to achieve high precision in the 1.5 MHz magnetic heads were developed by Earl G. Garthwait and William I. Girdner, and by Richard C. Sinnott, consultant.

-Gerald L. Ainsworth

### SPECIFICATIONS

#### -hp- MODEL 3950 MAGNETIC TAPE RECORDERS

##### Tape Transport

Reel Size: 10 1/2 to 15 in.

Tape Width and Thickness: 1/2 or 1 in. wide, 1.0 mil thick.

Transport Speeds: 120, 60, 30, 15, 7 1/2, and 3 3/4 ips. Other groups of six speeds available at extra cost.

Pushbutton Operating Controls: Stop, Play, Reverse, Forward, Record, Speed (6), and Power.

Remote Control: Connectors on rear permit remote control of all transport operations except speed selection.

Start Time: Within speed limits in 6 seconds; flutter within specifications in 10 seconds maximum.

Rewind Time: Approximately 4 minutes for 9200 ft., 4 1/2 minutes for 10,800 ft.

Drive System: Open loop, damped.

Total Interchannel Time Displacement Error (static and dynamic): ± 1 μs at 60 ips, ± 0.5 μs at 120 ips between two adjacent tracks on same head stack.

##### Flutter:

Speed	Bandwidth	Flutter (p-p)*
120 IPS	0-200 Hz	0.2%
	0-1.5 kHz	0.3%
	0-10 kHz	0.6%
60 IPS	0-200 Hz	0.2%
	0-1.5 kHz	0.3%
	0-10 kHz	0.6%
30 IPS	0-200 Hz	0.2%
	0-1.5 kHz	0.5%
	0-5 kHz	0.8%

\* If expressed as RMS flutter, the values would be 1/2 to 1/4 of those listed. Proposed 1966 revision of IRIG 106-65 specifies that flutter be within stated peak-to-peak limits 95% of the time. On this basis, values of flutter are substantially lower.

**Time Jitter:** The random jitter in the reproduced signal between any two events is typically within the following peak-to-peak 3 sigma limits (i.e., 99.7% of the time):

Tape Speed Inches/Sec	Time Interval Milliseconds	Jitter P-P Microseconds
120	0.1	0.3
120	1	1.5
60	0.1	0.4
60	1	2.0
30	0.1	0.4
30	1	3.0

**Tape Interruption Sensing:** Tape breakage or end-of-reel runoff is sensed by the take-up reel tensioning arm to stop the transport. It is unnecessary to prepare tapes with markers before use.

**Braking:** By feedback type mechanical brakes which provide power-fail-safe operation in all modes.

**Magnetic Head Assembly:** The head assembly meets IRIG document 106-65, Part 6 including mechanical geometry, numbering, azimuth, and polarity.

**Tracks:** 7 tracks on 1/2 in. and 14 tracks on 1 in. wide magnetic tape.

##### Drive Speed Accuracy:

Standard 60 Hz ± 0.03% Commercial Power: ± 0.25% of nominal capstan speed with 1.0 mil tape. Speed proportional to line frequency.

47 to 63 Hz Line Frequency: ± 0.25% of nominal capstan speed with 1.0 mil tape when capstan is powered by optional HP 3680A Stable AC Power Source; ± 0.02% of nominal capstan speed using optional HP 3680A Stable AC Power Source and 3681A Tapespeed Servo, meets IRIG 106-65, Section 6.3.6.3.

**Tape Footage Counter:** 5 digits, ± 0.05% accuracy.

##### Direct Record/Reproduce System

###### Frequency Response:

Speed (ips)	Bandwidth*	S/N Ratio**	Maximum Rise Time***
120	0.4 kHz-1.5 MHz	> 30 dB	< 0.4 μs
60	0.4 kHz-750 kHz	> 29 dB	< 0.8 μs
30	0.4 kHz-375 kHz	> 29 dB	< 1.6 μs

\* ± 3 dB 10 kHz to upper band edge; ± 4 dB 0.4 kHz to upper band edge.

\*\* Signal frequency at 0.1 x upper band edge; record level at 1% 3rd harmonic distortion on tape using -18 dB/octave filter 2 dB down at band edge.

\*\*\* Fundamental of square wave at 0.1 x upper band edge.

**Equalization:** Each amplifier will accommodate three equalizers to meet requirements of IRIG standard 106-65.

**Input Level:** 0.25 to 30 volts rms.

**Input Impedance:** 1000 ohms, 70 pf, unbalanced to ground.

**Output Level:** Up to 1 volt rms into 75 ohms.

**Output Impedance:** 75 ohms, unbalanced to ground.

**Harmonic Distortion:** When recording at the normal level (1% third harmonic distortion on tape) or less at any frequency, electronically caused distortion is less than 1/2 % of signal.

##### Front-panel Operating Controls:

Record: Record Level Meter Adjust, Record Level Control, Bias Level Control, Bias Indicator Switch, and Bias and Input Test Points.

Reproduce: Output Gain Control, Equalizer Amplitude Adjust, and Pre-amp Output Test Points.

**Signal Connectors (input and output):** BNC female.

##### Prices:†

-hp- Model	Reel size (max. in.)	Tracks	Direct Systems <sup>2</sup>	Price	FM Systems <sup>3</sup>
3950A	15	14	1.5 MHz	\$19,700	dc to 20 kHz
3950B	15	7		\$13,350	\$14,015

1. Standard features included in all systems at above prices.

- Meters on all record channels.
- Meter switched in each reproduce mainframe.
- Tape footage counter.
- Bias oscillator in record mainframes.
- Reel of high quality instrumentation tape and empty reel.

2. With a full set of reproduce as well as record amplifiers. Direct record amplifiers operate at all six speeds. Above prices include speed-related networks for any three speeds for all Direct Reproduce, FM Record, and FM Reproduce amplifiers.

3. DC to 400 kHz wideband FM optionally available.

##### MANUFACTURING DIVISION:

-hp- Microwave Division  
1501 Page Mill Road,  
Palo Alto, California 94304

Prices f.o.b. factory  
Data subject to change without notice.

# A Current Preamplifier for Magnetic Tape Playback Systems

**I**N THE article describing the *hp-* model 3950 Tape Recorder on page 2 of this issue, mention is made of the current sensing preamplifier<sup>1</sup> used in the playback system. This novel method eliminates many of the disadvantages associated with present wideband, high frequency reproduce systems which amplify the voltage generated by the tape head.

The tape wide-band voltage amplifier must be designed with an input impedance high enough so that the voltage output from the head will not be attenuated. In such high impedance systems, distributed input capacitance tunes with the inductance of the head to influence the high-frequency signal amplitude and phase characteristics. This means careful control in design and continuous adjustment during head life.

Also in voltage sensing systems a signal attenuation is found to occur at higher frequencies due to eddy current effects in the core of the head. These, together with gap losses and other effects, require additional high-frequency compensation.

<sup>1</sup> Patent applied for.

The use of a low-input impedance current amplifier is found to eliminate the effects of input capacity on the signal current and to minimize, if not remove, the effects of eddy current losses. It also provides for improved system signal-to-noise performance.

## EQUIVALENT CIRCUITS

In the simplified voltage equivalent circuit of a tape head, Fig. 1(a), the voltage generated across the amplifier input (when input impedance is high) is known to be proportional to the rate of change of flux through the head. The Norton equivalent circuit to Fig. 1(a), the current equivalent model, is shown in Fig. 1(b), and in greater detail in 1(c). It generates the identical voltage of Fig. 1(a). The signal current  $i_s$  from the familiar  $LI = n\phi$  equation, is proportional to  $n\phi/L$  and therefore is proportional to tape flux rather than rate of change of flux. Inspection of the current models, Fig. 1(b) and 1(c), shows that the use of a low-input impedance amplifier achieves a number of desirable features.

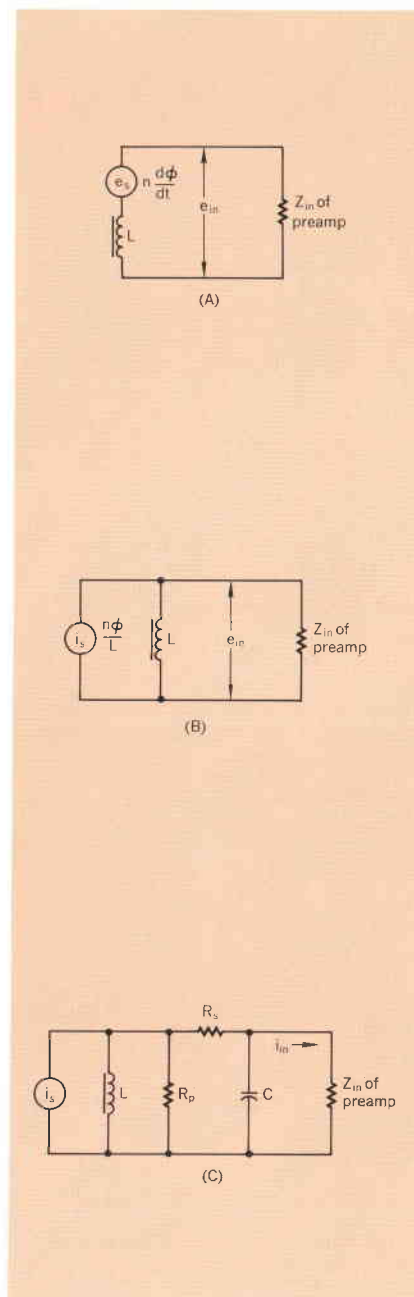

Fig. 1. Basic equivalent circuits of the head. The voltage equivalent model is shown at (A) and the current equivalent model at (B). Losses are detailed in the current equivalent head model (C).

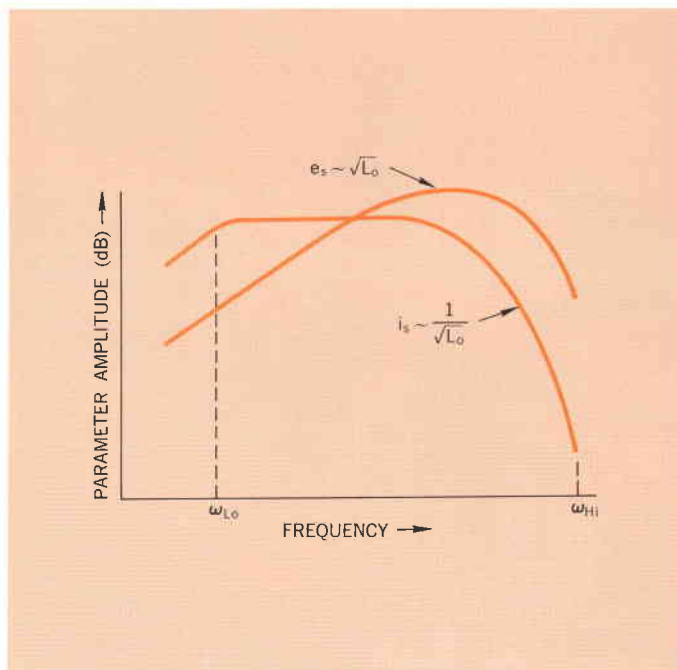

Fig. 2. Frequency characteristics compared for voltage and current models. The current model does not have the rising characteristic of the voltage model, but is flat for lower frequencies.

From Fig. 1(b) and 1(c) it is apparent that the distributed capacitance  $C$ , the head inductance  $L$ , and the core loss resistance  $R_p$  are shorted out by a low-input impedance  $Z_{in}$ . Thus the bandwidth limitations caused by capacitance are well above the highest frequencies of interest. Amplitude and phase variations due to tuning effects are therefore eliminated. Eddy currents which affect head inductance and core loss, and normally cause signal loss in voltage amplifier systems, now have a minimum effect on signal amplitude. The low frequency limit of the system is set by  $L$  in parallel with  $R_s$  plus  $Z_{in}$ .

Therefore, with a low-impedance input, the output will be that of the equivalent current generator,  $i_s$ , and will not exhibit the typical 6 dB/octave rising characteristic and head impedance influences found with voltage amplifiers. This also means that the signal amplitude is

essentially independent of tape speed, an important factor in amplifier design for multiple-speed tape systems.

Elimination of the 6 dB/octave characteristic means that low frequency equalization is no longer required (Fig. 2). But high-frequency attenuation is more severe and greater equalization is required to compensate for the high-frequency losses. (However, high-frequency equalization is needed with both voltage and current preamplifiers to compensate for high-frequency attenuation due to gap effects, etc.)

The equation for signal current,  $i_s = n\phi/L$ , calls attention to another interesting property of this system. Since  $L$  is proportional to  $n^2$ , it is apparent that the signal current is inversely proportional to the number of turns in the winding. Experimentally, signal amplitude does indeed increase with decreasing

turns, and contrary to the usual approach, makes it appear desirable to use as few turns as possible. However, signal-to-noise considerations are found to override this and dictate the optimum choice of head inductance.

The low-input impedance amplifier allows greater freedom in the design of the input circuit for optimizing the signal-to-noise ratio. In the *-hp-* systems, the head inductance, cable parasitics, and input circuit parameters have been chosen to maximize signal-to-noise ratio.

—Arndt B. Bergh



ARNDT B. BERGH

Arne Bergh joined *-hp-* in 1956 and has worked on advanced research and development of several instruments including the *-hp-* Model 428A and 428B Clip-on Milliammeter. He was in charge of the development of the Magnetometer and large aperture current probes for the 428B Clip-on Milliammeter probes. He also worked in the development of an ink tester used to determine magnetic content of ink used on bank checks. Arne received his BA degree from St. Olaf's College in 1947 and his MS in Physics from the University of Minnesota in 1950. He holds several patents, has several pending, and is a member of IEEE.

# Wideband Cavity-type Coaxial Frequency Meters

*A discussion of the construction used to achieve the broad frequency range of the -hp- microwave cavity wavemeter.*

**C**ALIBRATING a signal-generator dial is a good example of a task which calls for frequency measurements that are accurate within about 0.1%, or one part in 10<sup>3</sup>. Since the best dials have tracking errors of 1% or more, it is not necessary to use a calibration system which is more accurate (and more expensive) than a 0.1% system. There are many other situations in which 0.1% frequency measurements are sufficiently accurate, and in these situations the best frequency meter to use is a cavity wavemeter—a simple, inexpensive, passive device.

Two cavity wavemeters have been developed by the -hp- Microwave Division for measuring frequencies in coaxial systems. Although these units have both been in production for some time, they are still considerably more advanced than any other meter in their class. Unlike some cavity wavemeters, these two have wide bandwidths and are completely free from spurious responses.

The coaxial wavemeters are simply calibrated tunable cavities

coupled to coaxial transmission lines. To measure the frequency of a signal on the transmission line, the wavemeter is tuned until the transmitted power dips, indicating that the resonant frequency of the cavity is the same as the transmitted frequency, and that the cavity is absorbing power from the transmission line. The unknown frequency is then read from a calibrated dial on the wavemeter. Tuned off resonance, the wavemeters are just transmission lines, so they can be built into a system or used in a swept-frequency setup without interfering with other parts of the system. In operation, a detector and an indicator are required to monitor the transmitted power, as shown in the typical measurement setup of Fig. 1.

The two wideband -hp- coaxial wavemeters (Fig. 2) operate from 0.96 GHz to 4.2 GHz and from 3.7 GHz to 12.4 GHz. At resonance, they produce a dip of at least 1 dB in the transmitted power (Fig. 3); off resonance, VSWR is less than 1.2 in the lower frequency unit and less than 2.0 in the higher frequency

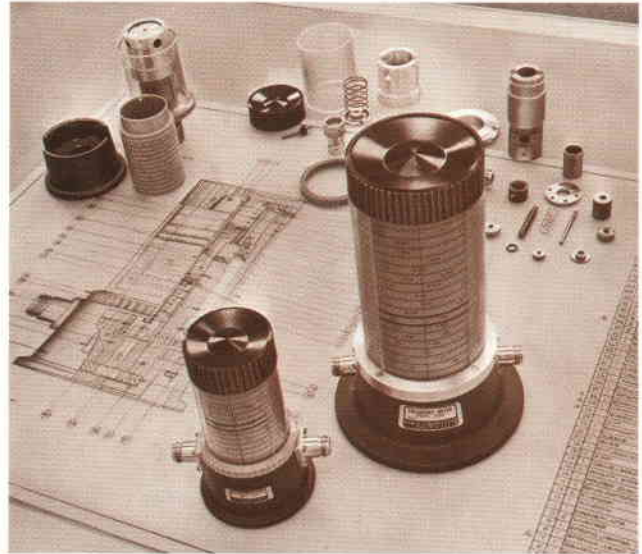

Fig. 2. -hp- Models 536A (r) and 537A (l) Coaxial Frequency Meters are inexpensive, reliable, and free from spurious responses over their frequency ranges, which are 0.96 GHz to 4.2 GHz and 3.7 GHz to 12.4 GHz, respectively. High-resolution spiral scales have tracking errors less than  $\pm 0.1\%$ .

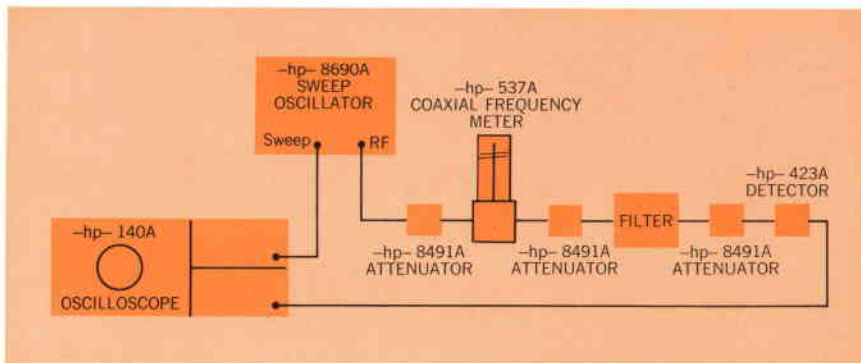

Fig. 1. Typical of the many uses of cavity frequency meters (wavemeters) is that shown here, i.e., providing an accurate frequency marker in a swept-frequency measurement of a filter response. Wavemeter's indication of frequency (a dip in the oscilloscope trace) is accurate within about  $\pm 0.1\%$  compared with  $\pm 1\%$  for signal-generator dials and markers.

unit. Cavity  $Q$ 's are 1500 to 4000 in the low-frequency version, and 1200 to 2000 in the high-frequency version.

Frequencies are read directly and with high resolution from the spiral scales of the two coaxial wavemeters. The scale of the 4.2-GHz wavemeter is 180 inches long and has calibration marks every 2 MHz. These marks are more than  $\frac{1}{16}$  inch apart, even at 4.2 GHz. The scale of the 12.4-GHz instrument is 80 inches long and has 10-MHz increments. Calibration marks are more than  $\frac{1}{32}$  inch apart, even at 12.4 GHz. Both scales read accurately within  $\pm 0.1\%$ . The extreme resolution and readability of these scales permit individual scale correction charts to be made so that readings

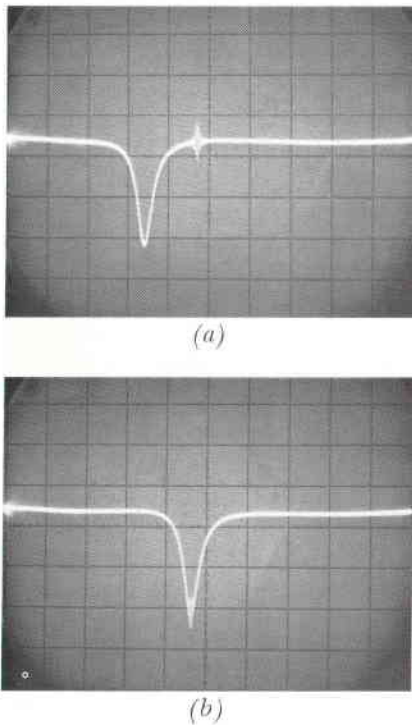
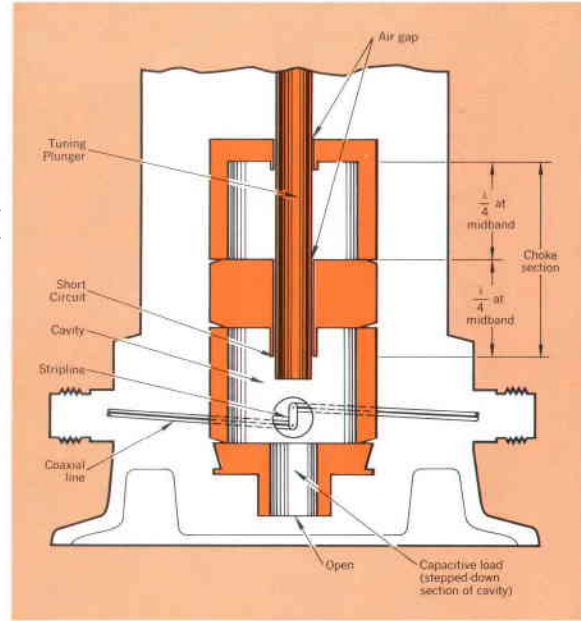

Fig. 3. Oscillograms showing dip produced by *-hp- 537A Frequency Meter*. Marker (derived from house frequency standard) is at 8.4 GHz. Cavity  $Q$  of Model 537A, measured on these oscillograms, is greater than 2000. (a) Wavemeter not tuned exactly to 8.4 GHz. (b) Wavemeter tuned to 8.4 GHz. Horizontal: 10 MHz/cm; Vertical: linear in power.

Fig. 4. Simplified cross-sectional view of Model 536A Frequency Meter. Cavity is tuned by moving plunger up and down. Choke section produces excellent short circuit between plunger and cavity walls at point indicated. Model 537A cavity is similar, but uses contacting fingers instead of choke section to produce sliding short.



can be repeated with errors much smaller than 0.1%. There are no spurious responses at any dial setting, and there is virtually no backlash in the tuning mechanism.

#### CAVITY DESIGN

The cavities used in the coaxial wavemeters are quarter-wavelength coaxial transmission lines, shorted at their upper ends and open at their lower ends (Fig. 4). Each wavemeter is tuned by moving a center conductor, or plunger, along the axis of the cavity, thereby changing the effective length of the cavity. One of the critical problems in the development of the wavemeters was that of achieving a good sliding short between the plunger and the upper end of the cavity. In the lower-frequency wavemeter, an excellent short is established by a choke section with an air dielectric (Fig. 4).<sup>1</sup> In the higher frequency version, contacting fingers are used instead of a choke section, and problems of rough tuning, low  $Q$ , and excessive wear have been avoided by choosing the proper materials, surface finish, and finger geometry.

To increase the bandwidths of the

wavemeters and eliminate three-quarter-wavelength spurious resonances, a 'loading capacitance' is added to the open end of each cavity by stepping down the diameter of the cavity near its bottom end (Fig. 4). At high frequencies the plunger is far away from the loading capacitance and the cavity appears to be a pure quarter-wave cavity. As the lower end of the band is approached, the plunger penetrates closer to the stepped-down section and the cavity becomes a quarter-wavelength cavity loaded with a capacitance.

Energy is coupled into the cavity by means of a well-matched section of stripline located near the stepped-down end of the cavity. Placing the coupling section near the stepped-down part of the cavity causes the coupling to be higher at low frequencies than at high frequencies because the plunger is closer to the stepped-down end of the cavity at low frequencies. Increasing the coupling at low frequencies helps compensate for the lowering of cavity  $Q$  by the loading capacitance at low frequencies, thereby making the response of the wavemeter at resonance more nearly the same at all cavity settings.

<sup>1</sup>For an introduction to choke couplings see G. C. Southworth, 'Principles and Applications of Waveguide Transmission,' D. VanNostrand Co., Inc., New York, 1950.

## MECHANICAL DESIGN

A simple but precise micrometer-type lead-screw drive positions the plunger of the low-frequency wavemeter to within  $\pm 0.0003$  inch and that of the high-frequency version to within  $\pm 0.0001$  inch. To insure that these tolerances will be maintained after long use and over wide temperature ranges, materials have been chosen which have compatible coefficients of expansion and high wear resistance. Maximum temperature coefficients between  $0^{\circ}\text{C}$  and  $55^{\circ}\text{C}$  are only  $0.0016\%/^{\circ}\text{C}$  for the low-frequency wavemeter, and only  $0.004\%/^{\circ}\text{C}$  for the high-frequency unit. Typical axial wear of the lead screw assembly is only  $0.0001$  inch after 10,000 cycles, equivalent to a frequency shift of one part in  $10^4$  at 4.2 GHz (low frequency version) and 2.5 parts in  $10^4$  at 12.4 GHz (high-frequency version).

## ACKNOWLEDGEMENTS

The authors are grateful to J. Keith Hunton for many suggestions in the early stages of the wavemeter developments and to James Ferrell

## SPECIFICATIONS

—hp—

### MODELS 536A AND 537A

#### COAXIAL FREQUENCY METERS

**FREQUENCY RANGE:** 536A, 0.96 GHz to 4.2 GHz; 537A, 3.7 GHz to 12.4 GHz.

**DIAL ACCURACY:**  $\pm 0.1\%$  ( $\pm 0.15\%$  for 536A from 0.96 to 1.0 GHz).

**OVERALL ACCURACY** (dial accuracy plus allowance of  $\pm 0.02\%$  for 0 to 100% relative humidity,  $\pm 0.0016\%/^{\circ}\text{C}$  from  $13^{\circ}$  to  $33^{\circ}\text{C}$ , and  $0.03\%$  backlash):  $\pm 0.17\%$  ( $\pm 0.22\%$  for 536A from 0.96 to 1.0 GHz).

**DIP AT RESONANCE:** At least 1 dB (0.6 dB for 536A from 0.96 to 1.0 GHz).

**REFLECTION COEFFICIENT OFF RESONANCE:** 536A,  $< 0.091$  (1.2 VSWR, 20.8 dB return loss); 537A,  $< 0.33$  (2.0 VSWR, 9.5 dB return loss).

**CALIBRATION INCREMENTS:** 536A, 2 MHz; 537A, 10 MHz.

**CONNECTORS:** Type N female.

**PRICE:** 536A, \$500; 537A, \$500.

#### MANUFACTURING DIVISION:

—hp— Microwave Division

1501 Page Mill Road,

Palo Alto, California 94304

Prices f.o.b. factory

Data subject to change without notice.

for the mechanical design of the low-frequency coaxial wavemeter. Kendall G. Caldwell made several contributions to the final form of the high-frequency coaxial wavemeter.

—Stephen F. Adam and  
Anthony S. Badger

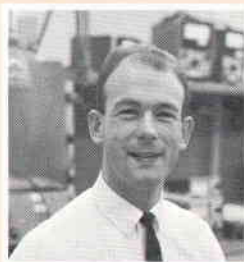

ANTHONY S. BADGER

Tony Badger joined the —hp— Microwave Division in 1960 after receiving his B.S. degree in mechanical engineering from Stanford University. He has contributed to the mechanical design of a number of instruments, and had project responsibility for the mechanical design of the 8690A Sweep Oscillator. He was project supervisor for development of the 537A Coaxial Wavemeter and of a precision 7mm coaxial connector; he holds a patent on the connec-

tor. Currently, he is project supervisor for the development of a new series of signal generators and attenuators, and he is working towards his M.S. degree at Stanford on the —hp— Honors Cooperative Program.

A remarkably active person, Tony has helped to develop the mechanical design case study program now in use at Stanford and other universities, has served three terms on the senior mechanical design judging panel at Stanford, and is president of his own product design and manufacturing company. He has recently purchased the yacht, Gaucho, from its first owner, Ernesto Uriburu, who sailed it around the world four times. Says Tony: 'For a long time my wife and I have had a desire to travel. We plan to sail the yacht back to San Francisco from Washington, D.C., as the first stage in our ultimate dream of a five-year world cruise.'

A biography of Stephen F. Adam appears on page 19.

THIS note describes a simplified test technique for evaluating and optimizing performance of a step recovery diode in a single stage frequency multiplier.

To optimize the performance of a frequency multiplier, the general procedure is to tune alternately the matching circuit to reduce the reflected power and to adjust the bias and output cavity for maximum power out at a single frequency (see Fig. 1). Nevertheless, as the reflected power is reduced the bias must be readjusted. Readjustment of the bias in turn requires further tuning of the matching circuit, and possibly the cavity. This back and forth process continues until what is believed to be optimum performance is achieved. This could be a tedious and time-consuming procedure.

To eliminate this difficulty and to facilitate optimizing the performance of the multiplier, the bias is applied from a 1 kHz negative going saw-tooth voltage generator of low output impedance. This saw-tooth bias is simultaneously applied

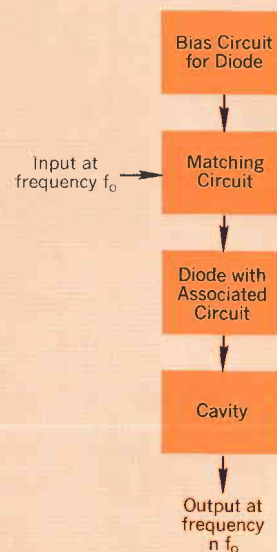

Fig. 1. General frequency multiplier block diagram.

# Simplified Technique For Evaluating Diode RF Performance

to sweep an oscilloscope while the output power is being observed. Fig. 2 shows an actual test setup used to evaluate the *hpa* 0320 diode. A 2301 hot carrier diode is connected across the output of the *-hp-*465A amplifier to clip the positive portion of the saw-tooth.

In practice the input power to the multiplier is adjusted by means of the variable attenuator with a 50-ohm load temporarily substituted for the multiplier. The deflection on the oscilloscope is calibrated to indicate the desired output power level. To record the exact output power more accurately, the saw-tooth is disconnected by means of the switch SW, and either the self

bias potentiometer R or the bias supply is adjusted to give the same maximum deflection indicated when the bias was swept.

This technique of displaying output power vs. bias enables rapid evaluation of a step recovery diode in a harmonic generator for maximum power output. In addition, spectrum breakup and abrupt changes of power output vs. bias can also be easily observed if present. Furthermore, sweeping the bias permits instant evaluation of diode performance over its entire operating bias range and reduces test time considerably. Fig. 3 is a photograph of an actual display of detected power out at 10 GHz vs. bias volt-

age. The diode being tested is the *hpa* 0320. This particular photograph reveals the possibility of multiple power peaks, a condition which would not be readily apparent if swept bias were not employed.

The author would like to acknowledge the assistance of David Jacoby who assembled the equipment and performed many measurements.

—Bernard Levine

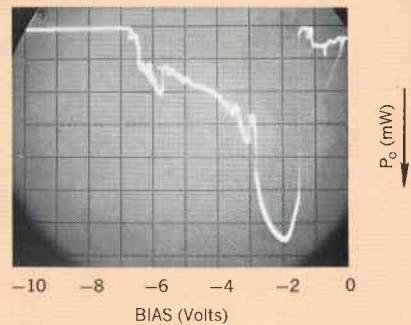
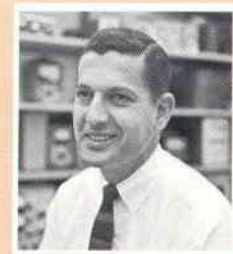

Fig. 3. Oscillogram taken with test setup of Fig. 2, showing detected power out of *hpa* 0320 multiplier at 10 GHz as a function of bias voltage.



BERNARD LEVINE

Bernie Levine joined *hp associates* in May 1966 as a test engineer responsible for the design and fabrication of microwave test equipment for the test and evaluation group. Before joining *-hp-* he was a test engineer for microwave tubes and solid state devices, and he has also been a tube design engineer on low-power transmitting tubes. Bernie is a graduate of City College, New York, where he received his BS degree in Electrical Engineering. He has also done graduate work at Stevens Institute of Technology. He holds a patent in the control circuit field.

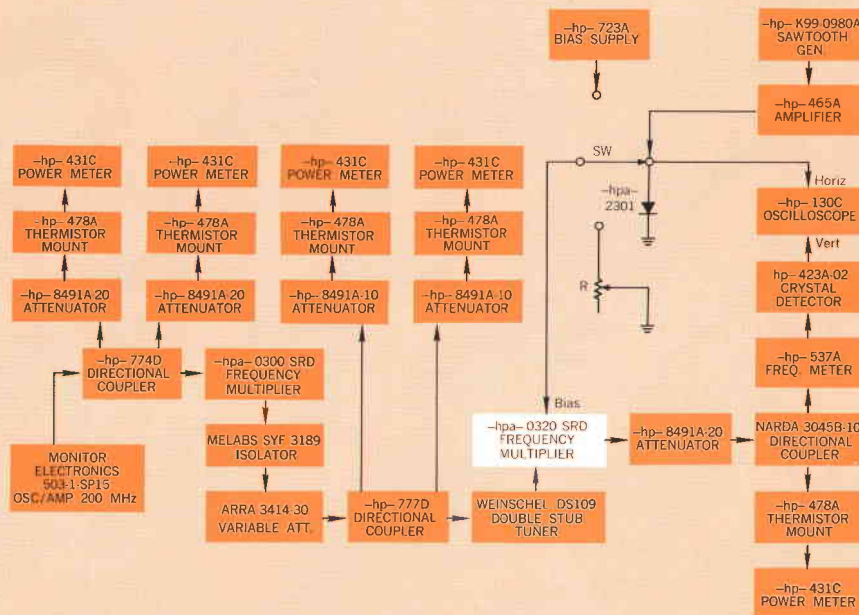
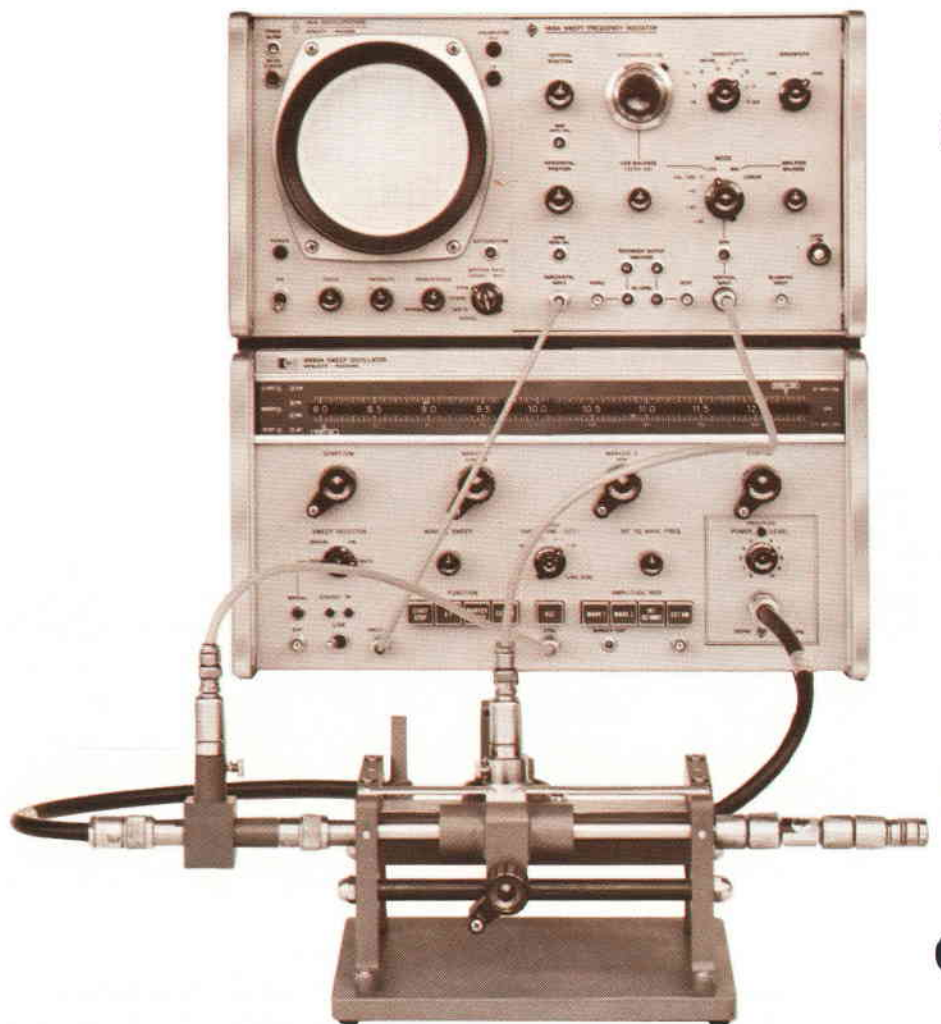

Fig. 2. Block diagram for new, simpler procedure for optimizing performance of a step recovery diode multiplier. Diode being tested here is *hpa* 0320.

# Swept-Frequency SWR Measurements in Coaxial Systems



**An important new swept-frequency technique permits quick and accurate measurements of SWR in coaxial systems up to 18 GHz.**

**C**OAXIAL COMPONENTS are lighter and smaller and generally have much wider bandwidths than equivalent waveguide units. However, despite these advantages of coax, its use has until recently been limited to frequencies below a few GHz, mainly because the best 7-mm connectors available—the type N connectors developed during World War II—have had excessive standing wave ratios at high frequencies. Now, as a result of the urging of the IEEE Subcommittee on Precision Connectors and the ASA C83.2 Committee, the microwave industry has developed precision 7-mm coaxial connectors which will operate at frequencies up to 18 GHz with respectably low SWR.<sup>1</sup> Consequently, coax can be expected to replace waveguide in this frequency range, at least for those applications where the lower insertion loss and higher power-handling capabilities of waveguide are not needed.

Swept-frequency SWR-measuring techniques for coaxial systems, chiefly reflectometer methods, have also been unsatisfactory at frequencies above 2 or 3 GHz, not only because of the high SWR of the connectors, but also because of the low directivity of directional couplers at these frequencies.<sup>2</sup> Fortunately, there is a new swept-frequency

technique for measuring SWR in coax.<sup>3,4</sup> This method employs a slotted line fitted with the new connectors, and its accuracy is excellent from 2 GHz to 18 GHz. Hence the method is suitable for testing all of the new coax components.

As might be expected with a new technique, the convenience and accuracy of the slotted-line method are greatest when equipment is used which has been specially designed for the application. In this instance only one special item is needed, a slotted-line sweep adapter designed and built by the *-hp-* Microwave Division. The other instruments needed are general-purpose *-hp-* instruments, although one of them, an 18-GHz, low-SWR slotted line fitted with the new connectors, is also a new development. Besides the slotted line sweep adapter and the slotted line and its carriage, the slotted-line method requires a sweep oscillator and an oscilloscope. The *-hp-* variable-persistence oscilloscope with the swept-frequency indicator plug-in turns out to be ideally suited for this application.

**SWEPT-FREQUENCY SWR MEASUREMENT WITH A SLOTTED LINE**

The equipment setup for the new SWR-measuring technique is illustrated in Fig. 1. The sweep oscillator output is connected to the input of the slotted-line sweep adapter, which is essentially a short piece of slotted line with a stationary detector probe. The output of the adapter's probe is connected to the ALC input of the sweep oscillator, forming a power-leveling feedback loop.

The slotted line is placed between the slotted-line sweep adapter and the device whose SWR is being measured, and the output of the detector probe of the slotted line goes to the vertical input of the oscilloscope. The horizontal input of the oscilloscope is taken from the sweep output of the sweep oscillator.

To permit the slotted-line probe output to be displayed on the oscilloscope with sensitivities as high as 0.5 dB/cm, the sweep-oscillator output must be held reasonably constant as the frequency varies. The function of the slotted-line sweep adapter is to level the oscillator power output in such a way that the voltage output of the slotted-line probe remains constant with frequency, except for the variations caused by the SWR being measured. The adapter consists of a short length of slotted line, a well-matched 6-dB attenuator, and two *matched* detector probes, one for the adapter and one for the slotted line. Matching the two probes makes the frequency response of the adapter probe, which samples the oscillator power, exactly equal to the frequency response of the slotted-line probe. Thus the oscillator power is adjusted to keep the output of the slotted-line probe constant with frequency. The 6-dB attenuator improves the frequency response, probe isolation, and impedance match of the adapter.

The slotted line shown in Fig. 1 is a new precision 'slab-type' line with very well matched transitions at each end. Connectors can be either the precision 7-mm type or improved type N connectors which also operate up to 18 GHz but have slightly higher SWR. With the 7-mm connectors, the residual SWR of the slotted line varies from 1.02 at 2 GHz to 1.04 at 18 GHz. With

<sup>1</sup> SWR  $< 1.003 + 0.002 \times \text{frequency (GHz)}$ . See IEEE Transactions on Instrumentation and Measurement, Vol. IM-13, No. 4, December, 1964, p. 285.

<sup>2</sup> Hewlett-Packard Application Note 65, 'Swept Frequency Techniques.'

<sup>3</sup> G. V. Sorger and B. O. Weinschel, 'Swept Frequency High Resolution VSWR Measuring System,' Weinschel Engineering Company Internal Report 90-117, 723-3/66, March, 1966.

<sup>4</sup> Hewlett-Packard Application Note 84, 'Swept SWR Measurement in Coax.'

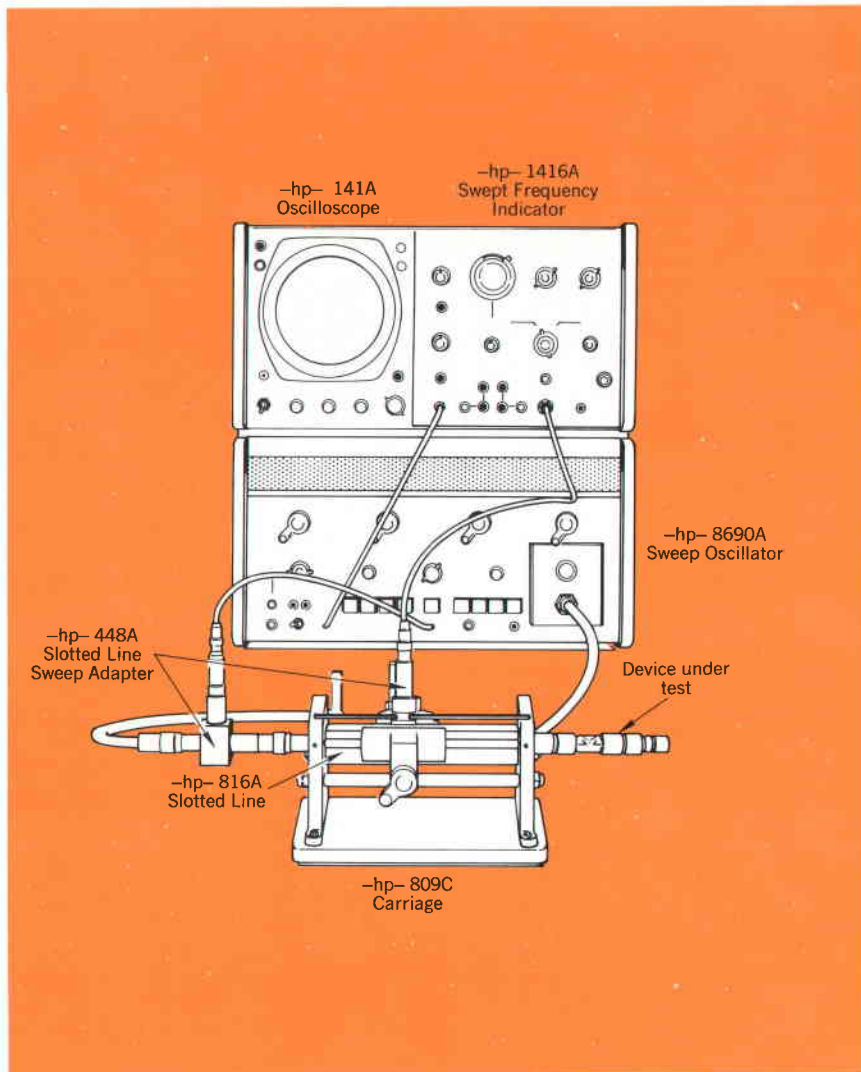

Fig. 1. Equipment setup for swept-frequency SWR measurements described in text. Method is highly accurate from 2 GHz to 18 GHz.

the type N connectors, SWR is 1.03 at 2 GHz and 1.06 at 18 GHz.

Although any oscilloscope can be used for displaying the slotted-line output, the variable persistence and storage feature of the one shown in Fig. 1 is particularly useful because it permits the unknown SWR to be read directly from the display. If a non-storage oscilloscope is used, the SWR data has to be photographed, using a time exposure. The swept-frequency-indicator plug-in is also a great convenience because it has a

logarithmic vertical amplifier which makes it possible to read SWR directly in dB.

#### OPERATION AND THEORY

Although in operation the sweep oscillator will be swept internally, the new SWR-measuring technique can be explained best by pointing out what happens at a fixed frequency. Fig. 2 is a series of oscillograms taken with the equipment of Fig. 1. In Fig. 2, points on the horizontal axis correspond to frequen-

cies between 8.2 and 12.4 GHz. The vertical scale factors are all 0.5 dB/cm.

Fig. 2(a) shows what happens at a single frequency when the slotted-line carriage is moved over at least one-half wavelength: the oscilloscope traces out a vertical line whose length is equal to the SWR (in dB) of the device being tested. That this is true can be shown as follows.

Transmission-line theory tells us that a uniform, lossless line terminated in an impedance which is not equal to its characteristic impedance will have two waves traveling on it in opposite directions. Besides the incident wave  $E_i$  traveling towards the load, there will be a reflected wave  $E_r$  going in the opposite direction. The incident and reflected waves will interfere and form a standing-wave pattern on the line. If the voltage on the line is measured, it will be found that there are points of maximum voltage

$$E_{\max} = |E_i| + |E_r|$$

and points of minimum voltage

$$E_{\min} = |E_i| - |E_r|$$

The maxima and minima will be one-half wavelength apart.

Standing-wave ratio is defined as

$$\text{SWR} = \frac{E_{\max}}{E_{\min}}$$

If the slotted-line carriage of Fig. 1 is moved over at least one-half wavelength, the oscilloscope spot will move up and down between  $E_{\max}$  and  $E_{\min}$ , and will trace out a line like that shown in Fig. 2(a). If the oscilloscope has a linear vertical amplifier,  $E_{\max}$  and  $E_{\min}$  can be read from the display and the SWR can be calculated. However, it is much better if the oscilloscope has a logarithmic vertical amplifier, because

the oscilloscope will then display a vertical line with length

$$\begin{aligned} \log_{10} E_{\max} - \log_{10} E_{\min} &= \log_{10} \frac{E_{\max}}{E_{\min}} \\ &= \log_{10} \text{SWR}. \end{aligned}$$

If the vertical amplifier is calibrated in dB/cm the SWR in dB is simply the length of the vertical line traced out on the display as the slotted-line carriage is moved over one-half wavelength or more. The SWR can easily be read from the trace and then converted to a voltage ratio by the formula

$$\text{SWR} = \log^{-1} \left( \frac{\text{dB}}{20} \right)$$

For the single frequency of Fig. 2(a), the SWR is about 0.5 dB or 1.06. Notice that when the display is logarithmic, only the vertical length of the trace is significant, and the baseline does not have to be displayed. Fig. 2(b) shows a series of traces corresponding to SWR measurements at several fixed frequencies.

Now if the sweep oscillator is swept internally several times per

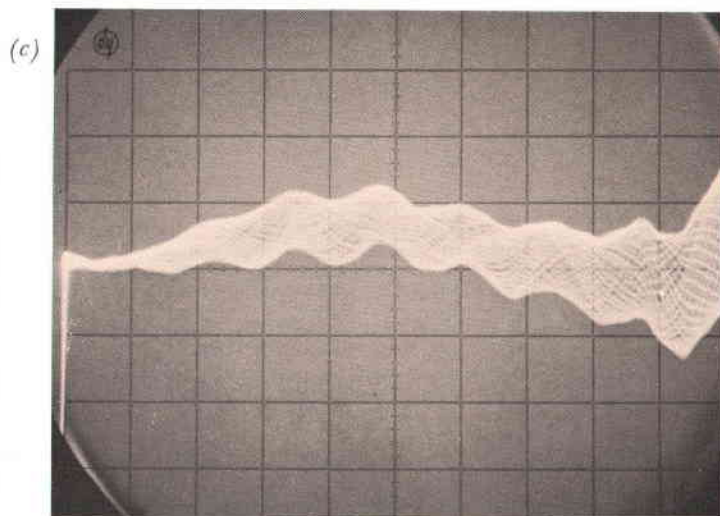
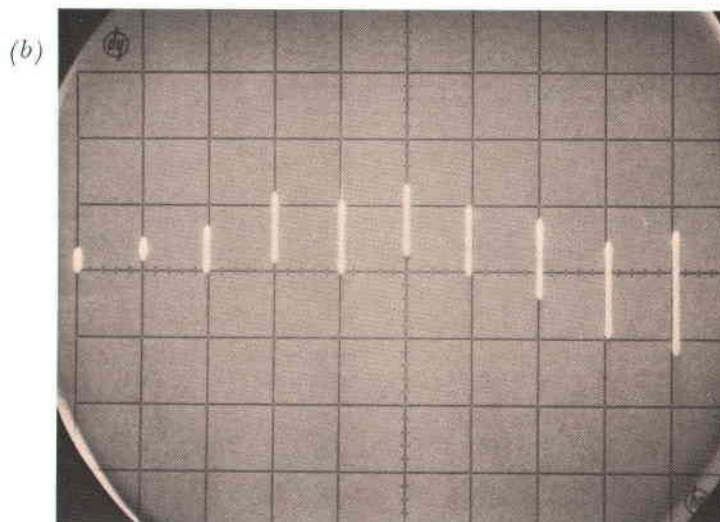
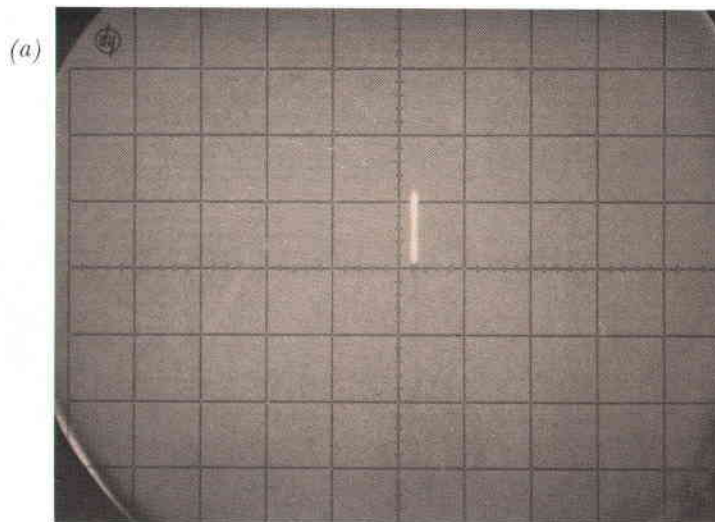

Fig. 2. Oscillograms made with setup of Fig. 1, showing measurement of SWR of a load.

(a) At single frequency, trace moves up and down as slotted-line carriage moves over at least one-half wavelength. With logarithmic display unit, length of vertical line is SWR in dB.

(b) Multiple exposure showing SWR measurements at several fixed frequencies across band.

(c) Typical pattern produced by swept-frequency measurement. Vertical: 0.5 dB/cm; Horizontal: 8.2 to 12.4 GHz.

second across the frequency band, and if at the same time the carriage of the slotted line is moved manually over at least one-half wavelength of the lowest frequency in the band, either a time exposure of the oscilloscope display or a stored pattern will look like Fig. 2(c). This technique, i.e., manually moving the slotted-line carriage while the oscillator sweeps automatically, is the normal one for making swept-frequency SWR measurements. It yields results like Fig. 2(c), in which the width of the pattern as a function of frequency corresponds to the SWR (in dB) of the device being tested.

### ERRORS

Sources of error in the swept-frequency slotted-line SWR-measuring technique are as follows.

**1. RESIDUAL SWR OF THE SLOTTED LINE.** This is the principal source of uncertainty and the limiting factor on the accuracy of the measurements. For the slotted line shown in Fig. 1, residual SWR (including the 'slope' of the slotted line, or the change in SWR with carriage position due to attenuation) is less than 1.03 to 12.4 GHz and less than 1.04 to 18 GHz, with the precision sexless 7-mm connectors. SWR with the improved type N male and female connectors is slightly higher. A residual SWR of 1.04 causes an uncertainty of  $\pm 2\%$  in the measured reflection coefficient  $\rho$ , which is related to the measured SWR by the relation

$$SWR = \frac{1 + |\rho|}{1 - |\rho|}$$

**2. SQUARE LAW ERROR OF THE CRYSTAL DETECTOR IN THE PROBE OF THE SLOTTED LINE.** The detector probes of Fig. 1 have square law errors which are specified to be less than 0.05 dB so long as the output voltage from the crystal is

less than 5 mV. The oscilloscope can be used to check the probe output of the slotted line to make certain that it is within this limit over the entire frequency range. Square law error can then usually be neglected in comparison to the residual SWR of the slotted line. If desired, the probe can be calibrated by precision instruments and its error eliminated entirely.

**3. CALIBRATION ERROR OF THE OSCILLOSCOPE.** Specified error of the swept-frequency-indicator plug-in shown in Fig. 1 is less than 0.02 dB/dB. This error is also small enough to be neglected in comparison to the slotted-line SWR, but it may be eliminated if desired by calibrating the display unit.

**4. FINITE WIDTH OF THE OSCILLOSCOPE TRACE.** This should be measured and subtracted from the width of the finished SWR pattern of Fig. 2(c). Fig. 3 is an example of a single trace, showing its thickness.

**5. IMPROPER BANDWIDTH/SWEEP RATE COMBINATION.** The sweep rate of the sweep oscillator and the bandwidth of the swept-frequency-indicator plug-in (Fig. 1) are adjustable. If the bandwidth is too low or the sweep rate too high, some of the fine structure of the SWR pattern will be lost. Usually the widest bandwidth and a fairly high sweep rate give the best pattern, but the optimum combination can easily be determined experimentally, by keeping the slotted-

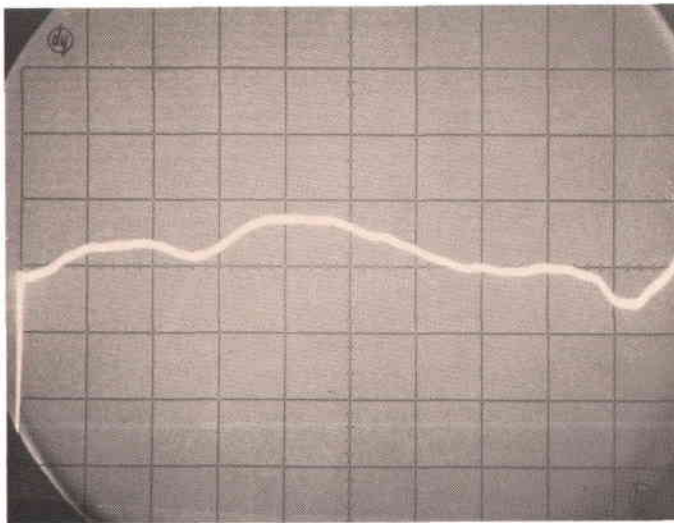

Fig. 3. Oscillogram made with slotted-line carriage stationary, showing finite width of trace which must be subtracted from SWR measurements.

**HEWLETT-PACKARD JOURNAL**  
 TECHNICAL INFORMATION  
 FROM THE LABORATORIES OF THE  
 HEWLETT-PACKARD COMPANY

VOL. 18, NO. 4 DEC. 1966

PUBLISHED AT THE CORPORATE OFFICES  
 1501 PAGE MILL ROAD,  
 PALO ALTO, CALIFORNIA 94304

Staff: F. J. Burkhard, Editor; R. P. Dolan  
 H. L. Roberts, L. D. Shergalis  
 R. A. Erickson, AD

line carriage stationary and adjusting the sweep rate and bandwidth for the most crooked trace.

#### 6. EXCESSIVE PROBE PENETRATION.

To minimize reflections from the probe of the slotted line, probe penetration should be the minimum amount consistent with the sensitivity of the display unit. This source of error is not significant in the setup of Fig. 1 because of the high (50  $\mu$ V) sensitivity of the display unit and the high power (>40 mW at 18 GHz) available from the sweep oscillator.

#### SLIDING LOAD FOR TWO-PORT DEVICES

When the SWR being measured is at one of the ports of a two-port device (e.g., a section of line, a connector, or an attenuator), the 'un-measured' port of the device must be terminated in its characteristic impedance. If the device under test has low loss (e.g., a line or a connector), the quality of the termination is very important, because any reflection from it will add vectorially to the voltage reflected by the device being tested.

In single-frequency SWR measurements and in swept-frequency

reflectometer measurements where imperfectly-matched loads have been troublesome, it has become standard practice to use a 'sliding load' for a termination.<sup>5</sup> A sliding load is simply a length of line with a movable termination; it permits the phase angle of the voltage reflected by the load to be varied without changing the magnitude of the reflection. By manipulating the phase of the load reflection, it is possible to separate the voltage reflected by the load from the voltage reflected by the device under test.

By terminating a two-port device in a sliding load, load-reflection errors can be eliminated from the results of the swept SWR-measuring technique described in this article. The sliding load is *mechanically linked* to the slotted-line carriage, so the distance between the slotted-line probe and the sliding termination is constant.<sup>6</sup> This keeps a constant phase angle between the incident voltage  $E_i$  and the part of the re-

<sup>5</sup> J. K. Hunton and W. B. Wholey, "The 'Perfect Load' and the Null Shift—Aids in VSWR Measurements," *Hewlett-Packard Journal*, Vol. 3, No. 5-6, Jan.-Feb., 1952.

<sup>6</sup> B. O. Weinschel, G. U. Sorger, S. J. Raff, and J. E. Ebert, "Precision Coaxial VSWR Measurements by Coupled Sliding-Load Technique," *IEEE Transactions on Instrumentation and Measurement*, Vol. IM-13, No. 4, December, 1964.



STEPHEN F. ADAM

Steve Adam studied mechanical and electrical engineering at the Technical Institute of Budapest, Hungary. He holds a degree equivalent to an M.S. in electrical engineering.

Steve joined the -hp- Microwave Division in 1957, after several years as a research and development engineer in Budapest. At -hp- he contributed to the design of the 532-series Waveguide Wavemeters and the 382-series Rotary-vane Attenuators, and was project supervisor for the 536A and 537A Coaxial Wavemeters and the 8491A, 8492A, and 354A Coaxial Attenuators. He has several patents pending. He is now an engineering group leader in the -hp- Microwave Laboratory and has responsibility for the development of a number of passive components.

Steve is a member of IEEE and an instructor of microwave electronics at Foothill College. He has recently been elected to the Board of Directors of the Bay Area Council for Electronics Education, an advisory group made up of representatives of northern California colleges and industries. "Among our present efforts is a program for improving the mathematics background of high school graduates in order to provide our engineering schools with more capable freshmen," he says.

### Standard Broadcast Frequency Offset for 1967

The frequencies of National Bureau of Standards HF standard broadcast stations WWV and WWVH and VLF station WWVL will continue to be offset -300 parts in  $10^{10}$  from the United States Frequency Standard during 1967, as they were in 1966. The offset enables the broadcast 1-second time intervals to approximate the UT2 time scale 1-

second intervals, which have been lengthening because of a very small retardation in the earth's rotational speed. The offset is determined by the Bureau Internationale de l'Heure, under the International Astronomical Union, for the purpose of coordinating standard time and frequency broadcasts on a world-wide basis.

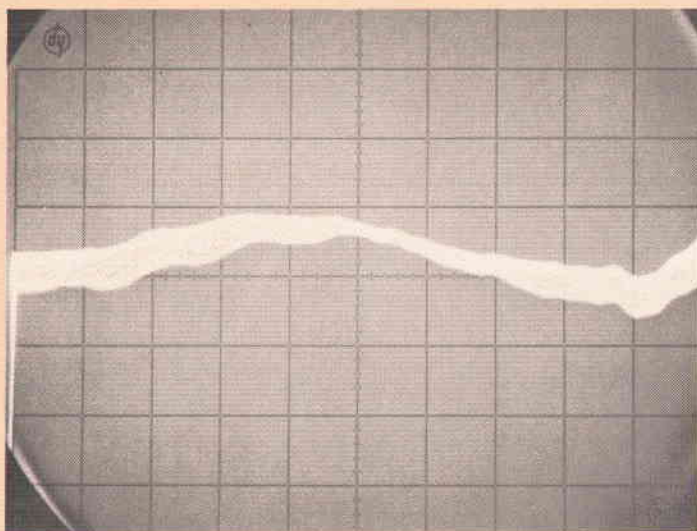

(a)

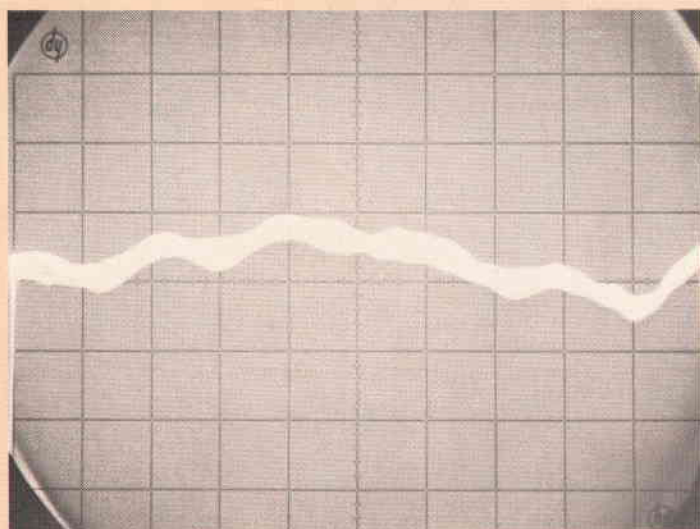

(b)

Fig. 4(a). Typical pattern for swept SWR measurements on slotted line with fixed load. (b) SWR pattern for same slotted line with sliding load mechanically linked to slotted-line carriage. Linking load and carriage eliminates load mismatch errors. Vertical: 0.5 dB/cm; Horizontal: 8.2 to 12.4 GHz.

flected voltage due to the sliding load ( $E_r$ ). The width of the oscilloscope pattern is then

$$\log_{10} \frac{|E_i + E_r| + |E_r|}{|E_i + E_r| - |E_r|}$$

where  $E_r$  is the voltage reflected by the device under test. If, as is usually the case,

$$|E_r| \ll |E_i|,$$

then the width of the oscilloscope pattern is due principally to  $E_r$  and is an excellent approximation to the SWR being measured. The principal effect of the load reflection is to move the entire pattern up and down; the effect of  $E_r$  on the width of the pattern is negligible.

The oscillograms of Fig. 4 show how much the width of the oscilloscope pattern changes when a sliding load is linked to the slotted-line carriage instead of remaining stationary. This change represents an improvement in the accuracy of the measurement. In Fig. 4 the measured SWR was the residual SWR of the slotted line and its connectors. When the load and carriage were linked, the apparent SWR at 12.4 GHz changed from roughly 0.35 dB, or 1.04, to roughly 0.15 dB, or 1.02.

#### ACKNOWLEDGMENTS

The slotted-line sweep adapter, the slotted line, and the slotted-line carriage shown in Fig. 1 were designed by Lawrence B. Renihan. I am also grateful to Richard W. Anderson for many helpful suggestions.

—Stephen F. Adam

# HP Archive

This vintage Hewlett-Packard document was  
preserved and distributed by

**[www.hparchive.com](http://www.hparchive.com)**

Please visit us on the web!

On-line curator: John Miles, KE5FX

[jmiles@pop.net](mailto:jmiles@pop.net)

