

HEWLETT-PACKARD JOURNAL

Cover: CUTAWAY VIEW OF MAJOR NEW 12 GHz
SAMPLING DEVICE; see pages 2 and 12

See also: CHARACTERISTICS OF CESIUM STANDARDS, page 16
OTHER ARTICLES, pages 9, 11, 19 and 20

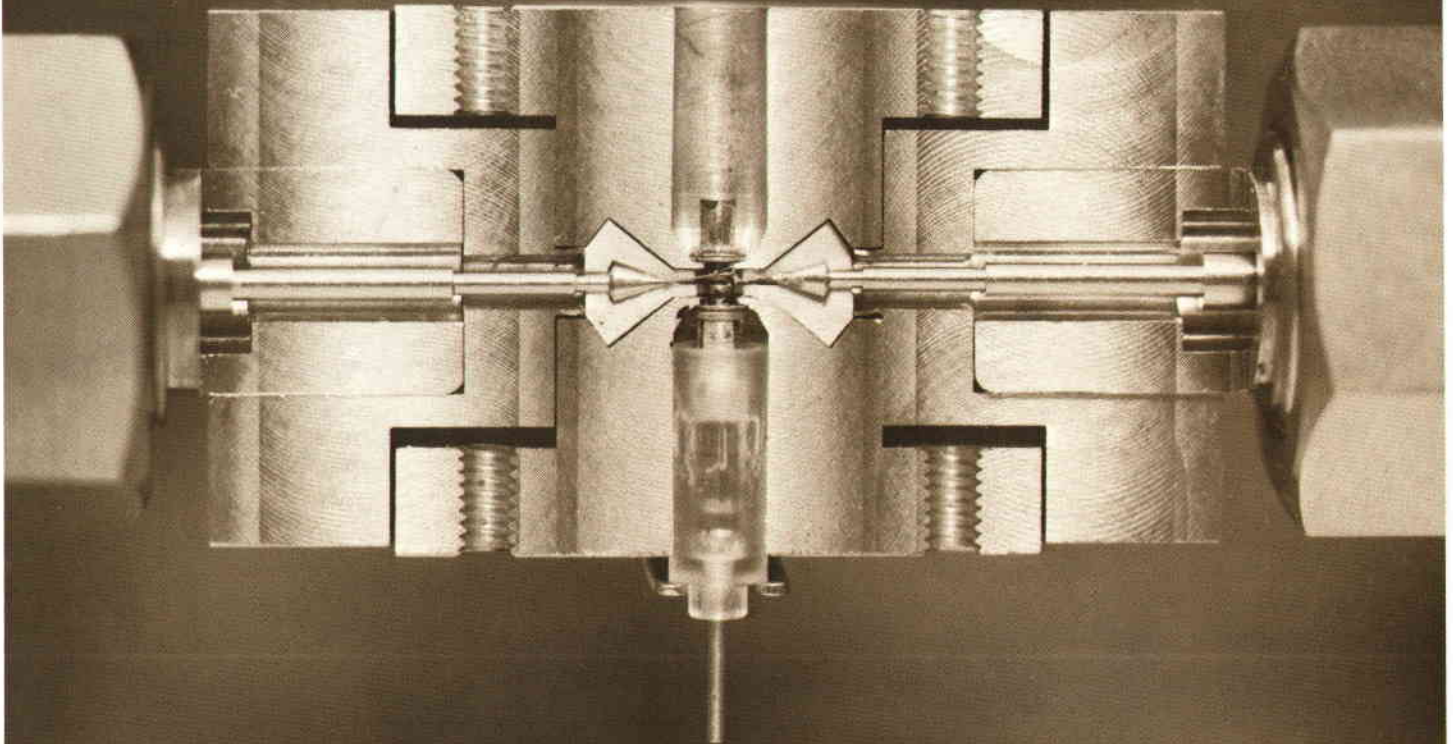

OCTOBER 1966

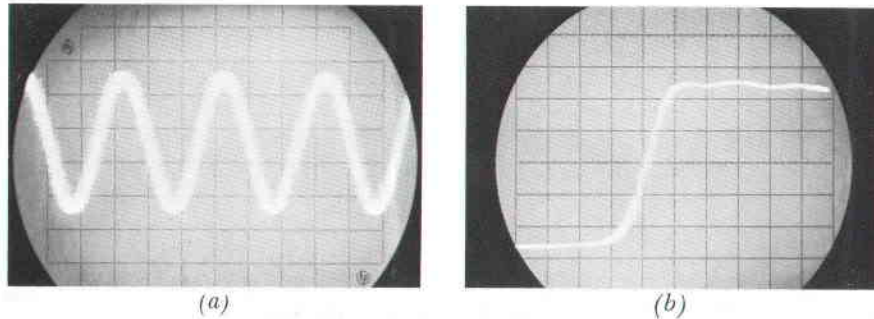

Fig. 1. Oscillograms of signals at frequencies never before viewed with oscilloscopes. (a). 18-gigahertz (18×10^9 cps) sine wave. (b). Step with 20-picosecond (20×10^{-12} s) rise time. Rise time of step response is about 30 ps, indicating that oscilloscope bandwidth is considerably greater than 12.4 GHz. Oscillograms were made using new sampling plug-ins discussed in text. (a) Vertical: 100 mV/cm, Horizontal: 20 ps/cm. (b) Vertical: 50 mV/cm, Horizontal: 20 ps/cm.

AN ULTRA-WIDEBAND OSCILLOSCOPE BASED ON AN ADVANCED SAMPLING DEVICE

The state of the oscilloscope art has taken a significant forward step with the development of a new oscilloscope that operates from DC to 12.4 GHz and displays signals as small as 1 millivolt.

SAMPLING oscilloscopes have a combination of wide bandwidth and high sensitivity that has never been matched by any real-time oscilloscope. This is because, up to now at least, it has been much easier to acquire, amplify, and display a narrow sample of a high-frequency repetitive waveform than to amplify and display the entire waveform.¹ This situation shows no signs of being reversed; in fact, the opposite is true. Four new sampling plug-ins for *-hp-* general-purpose and variable-persistence oscilloscopes have been developed, and among them is a vertical amplifier with a sensitivity of 1 millivolt per centimeter and a bandwidth greater than 12.4 GHz, more than three times the widest bandwidth previously attained.² The ultra-wideband vertical amplifier is based upon a remarkable new sampling device developed by *hp associates*. This device and the 'integrated' design approach

which produced it are described in the article beginning on p. 12.

Short, sharp pulses in high-speed computers and high-frequency pulsed radars, both present and future, are well within the range of the new oscilloscope, as are many microwave signals which have never before been observable. The two oscillograms of Fig. 1 could not have been made without the new sampling plug-ins; they are displays of an 18-GHz sine wave and a voltage step having a rise time of ap-

proximately 20 picoseconds (20×10^{-12} second). Overall rise time of the step display is about 30 ps, indicating that the plug-in's rise time is less than 28 ps, equivalent to a bandwidth of more than 12.4 GHz. By comparison, rise times of pulses in the fastest computers are now about one nanosecond and are getting faster.

Fig. 3 shows how the new sampling plug-ins are related to each other, to the oscilloscope main frames, and to some auxiliary equipment, which is



Fig. 2. Model 1425A Sampling Time Base and Delay Generator and Model 1410A 1-GHz Sampling Vertical Amplifier installed in Model 141A Variable Persistence Oscilloscope. Sampling gates in 1-GHz vertical amplifier are in probes. GR874 50Ω inputs lead to internal delay lines and trigger amplifiers for internal triggering.

¹ Principles of sampling oscilloscope operation have been presented several times in these pages. See, for example, R. Carlson, 'The Kilomegacycle Sampling Oscilloscope,' *Hewlett-Packard Journal*, Vol. 13, No. 7, Mar., 1962, and 'Coherent and Incoherent Sampling,' *Hewlett-Packard Journal*, Vol. 17, No. 11, July, 1966. Instead of displaying every cycle of a repetitive waveform, the sampling oscilloscope forms an apparently continuous trace from a series of dots, or samples, taken usually many cycles apart, each representing the input voltage at a slightly different point in its cycle.

² The four new sampling plug-ins fit the *-hp-* Model 140A General-purpose Oscilloscope and the *-hp-* Model 141A Variable-persistence Oscilloscope.

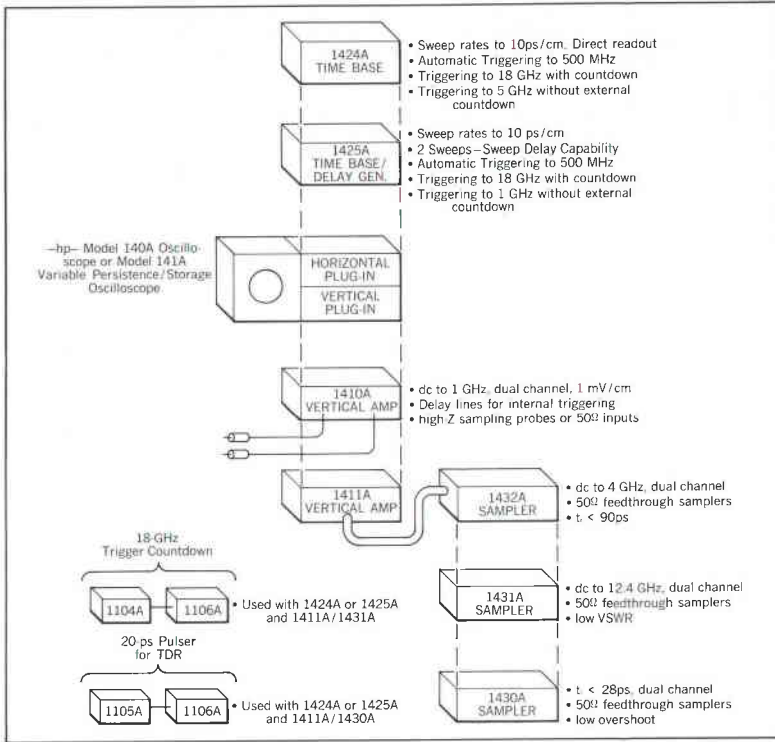

Fig. 3. New sampling plug-ins, remote samplers, pulse generator and trigger countdown unit for —hp— Model 140A and 141A Oscilloscopes are all solid-state. Units can be combined in various ways to form sampling oscilloscopes with bandwidths as high as 12.4 GHz, more than three times widest bandwidth previously attained.

also new. All of the plug-ins and other new instruments contain only solid-state active devices.

Two of the four plug-ins are time bases and two are vertical amplifiers, and either vertical amplifier may be used with either time base. The main frames are compact laboratory oscilloscopes (9 inches high), one having variable persistence and storage, and the other designed for general-purpose service where variable persistence is not required.

The auxiliary instruments, described in detail on p. 9, make it possible to take full advantage of the wide bandwidth and fast rise time of the new sampling oscilloscopes. These instruments are a tunnel-diode pulse generator for time domain reflectometry and other uses requiring fast pulses, and an 18-GHz trigger countdown for triggering on high-frequency CW signals. Rise time of the pulser is approximately 20 ps, making it one of the fastest now in existence.

Table I lists the major capabilities of each of the possible combinations of

plug-ins and auxiliary equipment. Besides wider bandwidth and faster rise time, other capabilities of one or more combinations of instruments are automatic triggering, sweep delay, triggering on CW signals up to 5 GHz without an external countdown, and a choice of high-impedance sampling probes or 50 Ω inputs with internal delay lines in a single vertical amplifier plug-in. All of these capabilities will be discussed at greater length later in this article.

Of the two vertical amplifier plug-ins, one is a dc-to-1-GHz unit, and the other is a general-purpose unit which operates in combination with one of three wideband remote samplers. Both vertical amplifiers are dual-channel units and both have maximum calibrated sensitivities of 1 mV/cm, much better than any wideband real-time oscilloscope.

Of the two horizontal plug-ins, one is a single-time-base unit with sweep speeds from 10 ps/cm to 500 μ s/cm. The other horizontal plug-in is a dual-sweep time base and delay generator with a similar range of sweep rates.

TABLE I. CAPABILITIES OF NEW SAMPLING PLUG-INS FOR —hp— MODEL 140A AND 141A OSCILLOSCOPES

Instrument Combination			Vertical: Bandwidth Rise Time Sensitivity	Horizontal: Triggering	Horizontal: Sweeps**
Vertical Plug-in/Sampler	Horizontal Plug-in	Auxiliary Instruments			
1410A/50 Ω Inputs* or High-Z Probes	1424A		dc to 1 GHz 350 ps 1 mV/cm	Automatic to 500 MHz, Internal* or External Level Select to 1 GHz, Internal* or External (CW to 5 GHz, External)	One
1410A/50 Ω Inputs* or High-Z Probes	1425A		dc to 1 GHz 350 ps 1 mV/cm	Automatic to 500 MHz, Internal* or External Level Select to 1 GHz, Internal* or External	Main, Delaying, Main Delayed
1411A/1432A	1424A		dc to 4 GHz 90 ps 1 mV/cm	Automatic to 500 MHz Level Select to 1 GHz (CW to 5 GHz)	One
1411A/1432A	1425A	18-GHz Trigger Countdown	dc to 4 GHz 90 ps 1 mV/cm	Automatic to 500 MHz Level Select to 1 GHz (CW to 18 GHz with countdown)	Main, Delaying, Main Delayed
1411A/1431A	1424A	18-GHz Trigger Countdown	dc to 12.4 GHz ~28 ps 1 mV/cm	Automatic to 500 MHz Level Select to 1 GHz (CW to 5 GHz, or 18 GHz with countdown)	One
1411A/1431A	1425A	18-GHz Trigger Countdown	dc to 12.4 GHz ~28 ps 1 mV/cm	Automatic to 500 MHz Level Select to 1 GHz (CW to 18 GHz with countdown)	Main, Delaying, Main Delayed
1411A/1430A	1424A		dc to ~12.4 GHz 28 ps 1 mV/cm	Automatic to 500 MHz Level Select to 1 GHz (CW to 5 GHz)	One
1411A/1430A	1425A		dc to ~12.4 GHz 28 ps 1 mV/cm	Automatic to 500 MHz Level Select to 1 GHz	Main, Delaying, Main Delayed
1411A/1430A	1424A or 1425A	20-ps Pulse Generator	TDR system with <40 ps rise time. Resolves discontinuities spaced <1/4 inch apart.		

* 50 Ω Inputs lead to built-in delay lines for internal triggering.
** Sweep rates: 10 ps/cm to 500 μ s/cm.

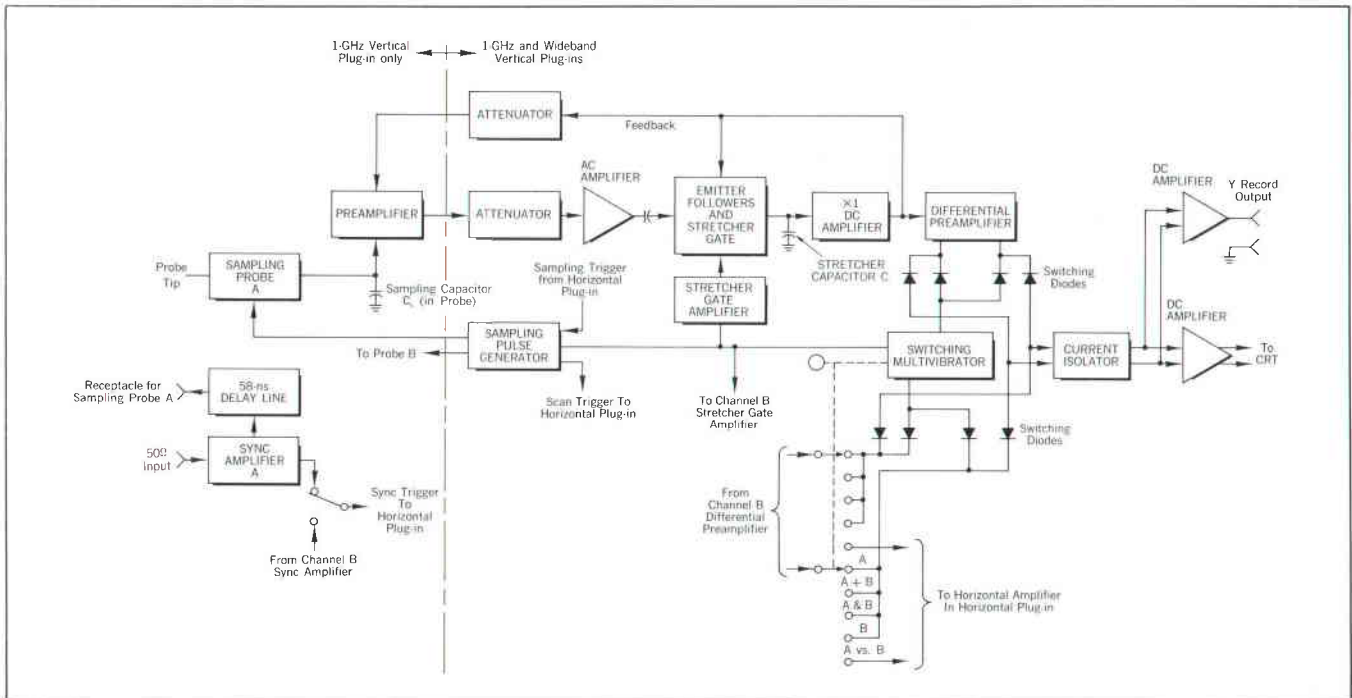

Fig. 4. Block diagram of Model 1410A 1-GHz Sampling Vertical Amplifier. Right side of diagram is identical in 1-GHz plug-in and in Model 1411A Sampling Vertical Amplifier.

Both plug-ins have trigger circuits which permit automatic triggering on a wide range of pulsed, CW, or other signals having frequencies between 50 Hz and more than 500 MHz. 'Automatic' triggering means that a baseline is displayed when the trigger signal is absent; then when a trigger signal is applied to the time base, the sweep is automatically synchronized to it. Reliable automatic triggering on a wide range of signals eliminates many trigger adjustments that would otherwise have to be made in the process of setting up a trace. These two plug-ins mark the first time that a sampling oscilloscope has had this capability, and therefore the first time that triggering a sampling oscilloscope has been as un-

complicated as triggering a real-time instrument.

A separate UHF countdown trigger circuit in the single-sweep plug-in permits this plug-in to trigger on CW signals having frequencies up to more than 5 GHz. The dual-sweep plug-in has no countdown, but will trigger reliably up to 1 GHz or more.

1-GHz VERTICAL AMPLIFIER

Fig. 2 is a photograph of the 1-GHz dual-channel vertical amplifier installed in the variable-persistence main frame along with the sampling time base and delay generator. Input signals to this plug-in are sampled by hot-carrier-diode sampling gates located in two high-impedance (100 k Ω , 2pF) probes. Delay lines and trigger ampli-

fiers built into the plug-in permit the oscilloscope to be triggered by either of its input signals (internal triggering) and still display the leading edge of the triggering signal. When the delay lines are used, the input signals are fed into two front-panel 50 Ω inputs and the sampling probes are plugged into receptacles on the front panel. Fig. 4 is a block diagram of the 1-GHz plug-in, showing a delay line and trigger amplifier at the lower left.

Although the plug-in's response extends to dc, there are no high-gain dc amplifiers in the signal path; the feedback loop shown in Fig. 4 makes them unnecessary. This means that the stability of the instrument can be and is high, because it is determined by passive components and a low-gain dc amplifier. Observed drift is less than 3 mV/hr.

A critical factor in making the plug-in all solid-state was the availability of low-leakage field-effect transistors for the stretcher gate and the dc amplifier shown in Fig. 4. Leakage in these transistors is so low that the sampling rate can be as low as one sample per second without resulting in excessive droop in the voltage on the stretcher capacitor. A field-effect transistor was also chosen

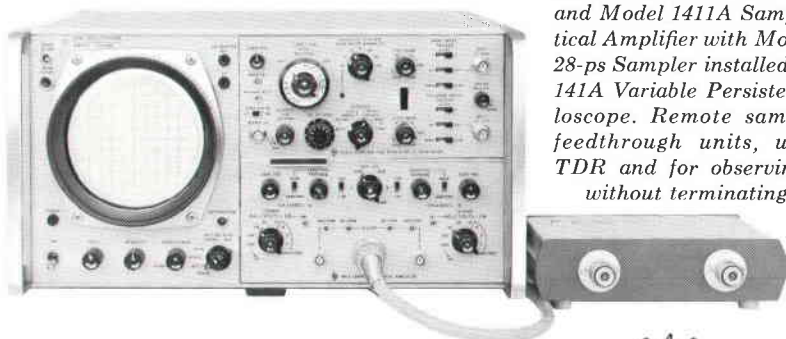

Fig. 5. Model 1425A Sampling Time Base and Delay Generator and Model 1411A Sampling Vertical Amplifier with Model 1430A 28-ps Sampler installed in Model 141A Variable Persistence Oscilloscope. Remote samplers are feedthrough units, useful for TDR and for observing signals without terminating them.

for the input stage of the preamplifier (Fig. 4) because of its low-noise characteristics.

Five display modes are possible for the vertical amplifier: channel A only, channel B only, channel A and channel B (alternate samples), channel A and channel B added algebraically and, for phase measurements or X-Y plots, channel A versus channel B. When both channel A and channel B are displayed, a switching multivibrator (Fig. 4) controls two groups of diodes which switch between the channels in synchronism with the sampling process. During one sampling interval the latest sample in channel A is displayed and during the next interval the latest sample in channel B is displayed. With this arrangement there is no chopper noise like that often found in real-time dual-channel displays.

Recorder outputs on the front panel of the 1-GHz vertical amplifier supply approximately 0.1 V/cm from a 500Ω source for driving strip-chart or X-Y recorders. The gain and dc level of the recorder output can be adjusted independently.

WIDEBAND VERTICAL AMPLIFIER AND SAMPLERS

Everything to the right of the colored line in the block diagram of Fig. 4 is identical in both the 1-GHz vertical amplifier and the wideband vertical amplifier. Sensitivities, display modes, recorder outputs, and internal operation are the same for both. The wideband unit, however, has no built-in delay lines and, instead of probes, uses one of the three dual-channel feedthrough samplers. Fig. 5 is a photograph of the wideband unit installed in the main frame, and Fig. 6 is a block diagram of the samplers.³

Depending upon which of the three wideband samplers is used, the bandwidth of the wideband vertical amplifier plug-in can be either 12.4 GHz or 4 GHz. Two of the samplers are ultra-wideband units. One has a rise time of less than 28 ps and optimum pulse response (overshoot < 5%) but a VSWR that increases with frequency (3 at 12.4 GHz); the other has a bandwidth of 12.4 GHz and a VSWR typically less

³ See article, p. 12, for a description of the wideband sampling devices used in these samplers.

Fig. 6. Block diagram of dual-channel remote samplers used with Model 1411A Sampling Vertical Amplifier. Ultra-wideband feedthrough samplers are described beginning on p. 12.

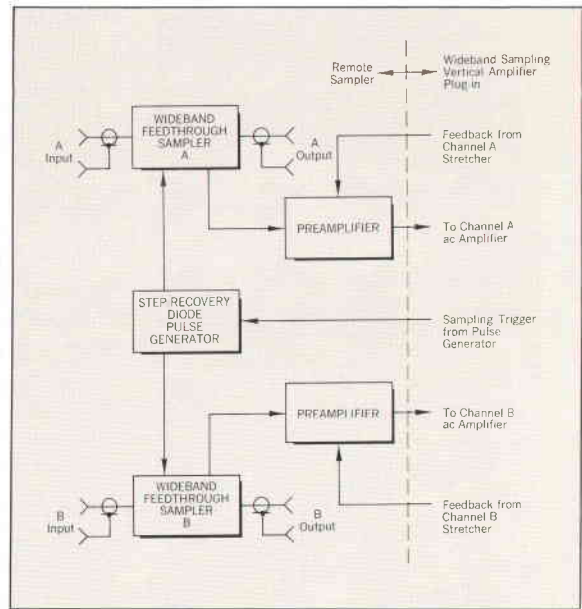

than 1.8 at 12.4 GHz, but has 5% to 10% more overshoot in the pulse response. The third sampler is a 4-GHz, 90-ps unit for applications where the widest bandwidths are not needed and lower cost is attractive. A five-foot cable (10-foot cable optional) connects the plug-in and the sampler so that measurements can be made at remote locations. Input signals are not terminated by the feedthrough samplers, so time domain reflectometry and signal monitoring are straightforward.

Oscillograms of 8-GHz and 18-GHz sine waves, taken using the low-VSWR (CW-optimized) sampler, are shown in Figs. 7 and 1(a) respectively. Note that time jitter is less than 10 ps, even at the highest frequencies.

Step response of the pulse-optimized sampler is shown in Figs. 1(b) and 8 for

two different time scales. The flat top and absence of excessive overshoot are evident in Fig. 8. Fig. 9 shows the reflection from the pulse-optimized sampler for an incident step having a rise time of 20 ps. The vertical scale is calibrated to read reflection coefficient with a scale factor of 0.1/cm, and the sampler reflection is only 6%.

TRIGGERING

Triggering of both the single-sweep time base⁴ and the dual-sweep time base and delay generator⁵ can be either automatic or manually adjustable and, when used with the 1-GHz vertical plug-in, either internal or external. Except for an extra UHF countdown in the single-sweep unit, all trigger circuits are identical circuits based on a newly designed tunnel-diode thresh-

⁴ See Fig. 10.

⁵ See Figs. 2 and 5.

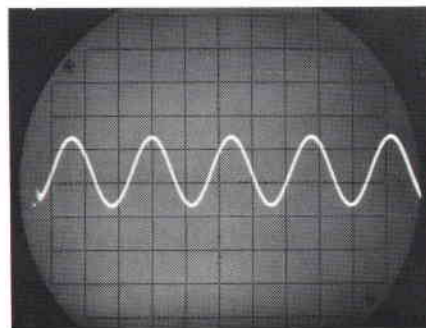

Fig. 7. Wideband sampling oscilloscope display of 8-GHz sine wave. See Fig. 1(a) for display of 18-GHz sine wave. Vertical: 20 mV/cm. Horizontal: 50 ps/cm.

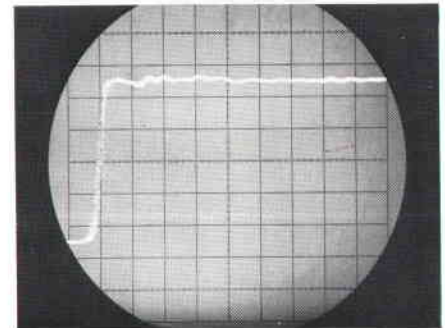

Fig. 8. Response of pulse-optimized Model 1430A Sampler to step with 20-ps rise time has 30-ps rise time, small overshoot, flat top. Vertical: 50 mV/cm; Horizontal: 100 ps/cm. See Fig. 1(b).

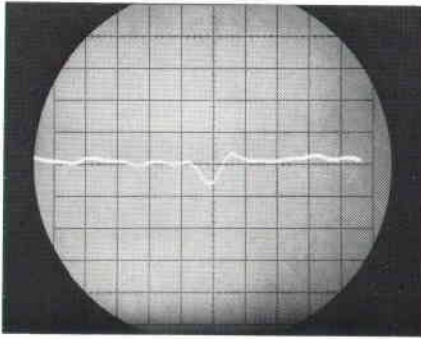

Fig. 9. Reflection from wideband sampler in 40-ps TDR system is only 6%. Vertical: reflection coefficient = 0.1/cm; Horizontal: 100 ps/cm.

old detector. The detector produces an output to start the sampling process when the incoming trigger signal crosses the level set by the LEVEL control. A SLOPE switch determines whether triggering will occur on the positive or negative slope of the trigger signal.

The threshold detector operates in one of three modes, depending upon the setting of the MODE control which varies the supply current to the detector. Turning the control clockwise increases the supply current. For low supply currents the detector is bistable, that is, the incoming signal must both trigger and reset the detector. As the current is increased the trigger circuit becomes monostable; that is, it is triggered by the incoming signal, but it resets itself. For still higher currents the circuit becomes astable and oscillates.

The bistable mode is used to trigger on the trailing edges of pulses or on pulses that are so long that the trigger circuit would normally re-arm and trigger again before the end of the pulse. The monostable mode is used to

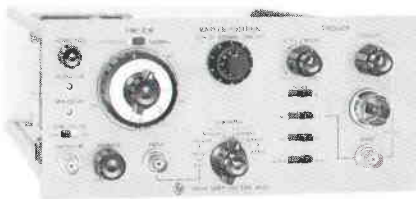

Fig. 10. Single-sweep Model 1424A Sampling Time Base Plug-in has calibrated marker position control and direct readout of both magnified and unmagnified sweep rates. Another new horizontal plug-in is dual-sweep time base and delay generator, shown in Figs. 2 and 5.

trigger on short pulses and on sine waves up to about 100 MHz. This mode is more sensitive than the bistable mode, especially on pulses shorter than about 30 ns. In the astable mode the detector oscillates at 10 to 40 MHz, depending upon the MODE control setting, and any incoming sine wave alters this frequency so that it is a sub-harmonic of the incoming frequency. This type of circuit is called a 'countdown,' because for triggering to occur the incoming frequency must be greater than the oscillation frequency. At about 100 MHz the astable mode is as sensitive as the monostable mode, but at 1000 MHz the astable mode is about twenty times more sensitive.

To prevent double triggering on complex waveforms in which the desired trigger level and slope appear more than once each cycle, both horizontal plug-ins have a variable hold-off control which can be used to increase the minimum time between samples.

SWEEP DELAY AND SWEEP EXPANSION

Like automatic triggering, sweep delay is a capability which has never before been possible for a sampling oscilloscope, but which is now available in one of the new horizontal plug-ins. The value of sweep delay for examining complex waveforms has long been recognized, of course, and real-time oscilloscopes have had delay generators for some time.

The two sweeps of the new sampling time base and delay generator operate in three sweep display modes: the displayed sweep can be a main sweep, a delaying sweep, or the main sweep delayed by an interval determined by the settings of the delay controls. Sweep delay is normally used to select any portion of a complex waveform for display on an expanded, faster time base. Therefore the main sweep rate is normally faster than the delaying sweep rate, although this need not be true.

Without sweep delay, sweep magnification was the only means for expanding details of a sampling-oscilloscope display, and both of the new horizontal plug-ins still have magnifiers. However, sweep magnifiers are usually limited to expansions of 100:1

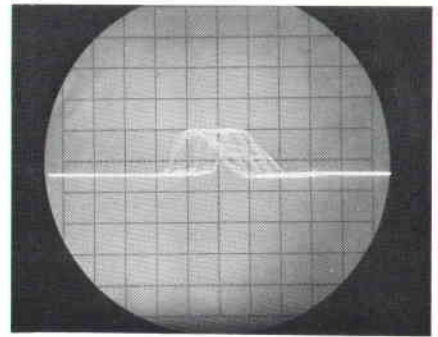
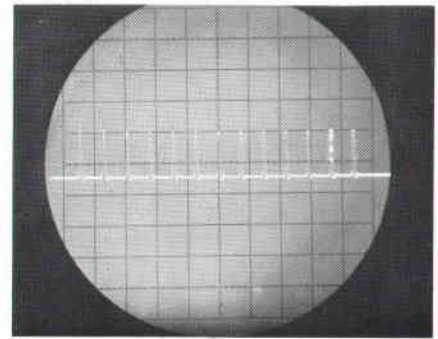

(b)

Fig. 11 (a). Pulse train displayed with main sweep of sampling time base and delay generator. Bright spot on 12th pulse indicates center of area to be magnified. (b) 12th pulse magnified $\times 20$. Note rate jitter, which is also magnified (see Fig. 12). Vertical: 100 mV/cm; Horizontal: (a) 100 ns/cm, (b) 5 ns/cm.

or less, whereas expansions of 10,000:1 or more are possible with sweep delay.

Another limitation of magnification alone becomes evident if the portion of the waveform to be magnified does not always occur at precisely the same time after the beginning of the sweep, as would be the case, for example, in a pulse train in which the period between pulses varies randomly. When the waveform is magnified, this 'rate jitter' will also be magnified and the signal may be difficult to observe. Fig. 11(a) is an oscillogram of a pulse-train display using the main sweep of the new delay-generator plug-in as the time base. The bright dot on the 12th pulse indicates the point about which magnification will occur when the MAGNIFIER control is turned to one of its six magnification settings ($\times 2$ to $\times 100$). Rate jitter in the 12th pulse of Fig. 11(a) is evident in the magnified display of Fig. 11(b).

With the delay-generator plug-in, rate jitter can be eliminated from the

display. Fig. 12(a) shows the pulse train of Fig. 11 displayed using the delaying (slow) sweep as the time base. Here the bright dot on the 12th pulse indicates the time at which the fast main sweep will start when the SWEEP switch is turned to MAIN DELAYED. The amount of calibrated delay is continuously variable from 50 ns to 5 ms. Fig. 12(b) shows the same pulse train using the delayed main sweep triggered normally (i. e., not automatically) after the delay interval. When triggered normally, the main sweep is merely armed at the end of the delay interval and is not triggered until the selected pulse occurs. The resulting display of Fig. 12(b) is entirely free of jitter. Had the main sweep been triggered automatically at the end of the delay interval, the display would have been identical to Fig. 11(b), with the rate jitter still present.

SYNC PULSE

Sync pulse outputs in both horizontal plug-ins provide pulses of about 1.5 V amplitude and 1 ns rise time.

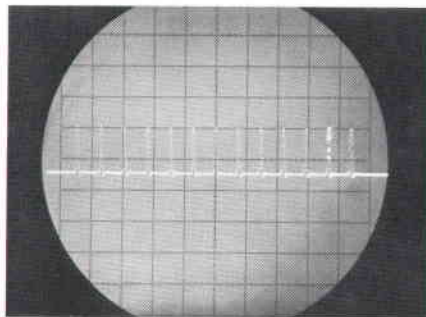

(a)

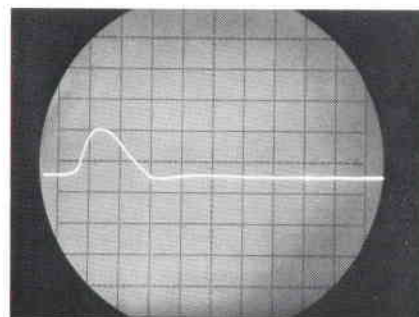

(b)

Fig. 12(a). Pulse train displayed with delaying sweep of sampling time base and delay generator. Bright spot on 12th pulse indicates start of delayed main sweep. (b) 12th pulse displayed with main sweep armed at end of delay interval and triggered on 12th pulse. Note absence of rate jitter. Vertical: 100 mV/cm; Horizontal: (a) 100 ns/cm, (b) 5 ns/cm, (c) 5 ns/cm.

These pulses are useful as pretriggers to drive a pulse generator or as driving pulses for a circuit being tested. They are exceptionally clean and flat-topped, and make excellent test pulses for time domain reflectometry.

In the single-sweep plug-in, the sync pulses are synchronized with the sweep. In the delay generator plug-in, they are synchronized with the main sweep so

that in addition to the above uses, they can be used as a calibrated-delay pulse source simply by setting the main sweep delay controls to the desired delay interval.

— Allan I. Best,
Darwin L. Howard and
James M. Umphrey

DESIGN LEADERS



ALLAN I. BEST

After spending three years in the U. S. Army, Al Best attended the University of California, graduating in 1960 with a BSEE degree. He then joined -hp- as a development engineer and contributed to the design of the 185B Sampling Oscilloscope, later assuming responsibility for the 185B after it went into production. After doing further work in sampling oscilloscope design, he transferred to Colorado Springs in 1964 and became design leader for the new sampling plug-ins for the 140A Oscilloscope. Al has one patent pending on delayed-sweep sampling time bases and another on a fast-ramp linearizer. Currently he is an engineering group leader in the -hp- Colorado Springs Laboratory, responsible for TDR and certain aspects of sampling.

Dar Howard joined -hp- in 1958 after graduating from the University of Utah with a BSEE degree. As a development

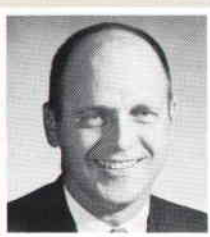

DARWIN L. HOWARD

engineer in the -hp- Microwave Laboratory, he contributed to the design of the 344A Noise Figure Meter and the 415C SWR Meter, and did further work on a phase-locked RF signal generator. In 1962, he received his MS degree in electrical engineering from Stanford University through the -hp- Honors Cooperative Program.

Dar transferred to the -hp- Oscilloscope Division (now at Colorado Springs) in 1963. As an engineering group leader, he organized the design group for the new sampling plug-ins for the 140A and 141A Oscilloscopes. In 1965 he assumed his present position of engineering manager, Colorado Springs Division.

Before deciding to become an electrical engineer, Dar attended Brigham Young University as an accounting major for one year, and then spent four years in the U. S. Navy as an electronics technician.



JAMES M. UMPHREY

Jim Umphrey received his BSEE degree in 1961 from Stanford University, then joined -hp- as a development engineer, working on the 187B and 187C Sampling Vertical Amplifiers and the 213B Pulse Generator. He transferred to Colorado Springs in 1964 and eventually assumed responsibility for the design of the 1104A/1106A Trigger Countdown, the 1105A/1106A Pulse Generator, and the wideband sampling vertical amplifier plug-ins for the 140A Oscilloscope. He is now an engineering group leader in the -hp- Colorado Springs Laboratory, with responsibility for a number of sampling and pulse-generator projects.

Jim received his MSEE degree from Stanford in 1961 on the -hp- Honors Cooperative Program. He is a member of Tau Beta Pi and IEEE.

CONDENSED SPECIFICATIONS

SAMPLING PLUG-INS FOR -hp- MODEL 140A OSCILLOSCOPE AND -hp- MODEL 141A VARIABLE-PERSISTENCE OSCILLOSCOPE

MODEL 1410A SAMPLING VERTICAL AMPLIFIER

MODE OF OPERATION: Channel A only; B only; A and B; A and B added algebraically; A vs. B.

POLARITY: Either channel may be displayed either positive or negative up in any mode.

RISE TIME: Less than 350 ps.

BANDWIDTH: dc to 1 GHz.

OVERSHOOT: Less than 5%.

SENSITIVITY: Calibrated ranges from 1 mV/cm to 200 mV/cm.

ISOLATION BETWEEN CHANNELS: Greater than 40 dB to 1 GHz.

INPUT IMPEDANCE:

Probes: 100 k Ω shunted by 2 pF, nominal.
GR Type 874 Inputs: 50 Ω \pm 2% with 58-ns internal delay lines for viewing leading edge of fast rise signals.

DYNAMIC RANGE: \pm 2 V.

DRIFT: Less than 3 mV/hr after warmup.

TRIGGERING: Internal or external when using 50 Ω inputs. Internal triggering selectable from Channel A or B. External triggering necessary when using probes.

TIME DIFFERENCE BETWEEN CHANNELS: <100 ps.

RECORDER OUTPUTS: Front panel outputs provide 0.1 V/cm from a 500 Ω source. Gain adjustable from approximately 0.05 V/cm to 0.2 V/cm. dc level adjustable from approximately -1.5 V to +0.5 V.

PRICE: \$1600.

MODEL 1411A

SAMPLING VERTICAL AMPLIFIER

(Used with 1430A, 1431A, or 1432A Sampler)

MODE OF OPERATION, POLARITY, SENSITIVITY, RECORDER OUTPUTS: Same as 1410A.

ISOLATION BETWEEN CHANNELS: 40 dB over bandwidth of sampler.

PRICE: \$700.

MODEL 1430A SAMPLER

(used with 1411A)

RISE TIME: Approximately 28 ps. (Less than 35 ps observed with 1105A/1106A pulse generator and 909A 50 Ω load.)

BANDWIDTH: dc to approximately 12.4 GHz.

OVERSHOOT: Less than \pm 5%.

DYNAMIC RANGE: \pm 1 V.

INPUT CHARACTERISTICS:

Mechanical: Amphenol GPC-7 precision 7 mm connectors on input and output.

Electrical: 50 Ω feedthrough, dc coupled. Reflection from sampler is approximately 10%, using a 40-ps TDR system, VSWR <3:1 at 12.4 GHz.

TIME DIFFERENCE BETWEEN CHANNELS: Less than 5 ps.

CONNECTING CABLE LENGTH: 5 ft. (10 ft. optional).

PRICE: \$3000 (\$3035 with 10-ft. cable).

MODEL 1431A SAMPLER

(used with 1411A)

BANDWIDTH: dc to greater than 12.4 GHz (less than 3 dB down from a 10-cm dc reference).

RISE TIME: Approximately 28 ps.

VSWR: dc to 8 GHz <1.4:1
8 to 10 GHz <1.6:1
10 to 12.4 GHz <2.0:1

DYNAMIC RANGE: \pm 1 V.

INPUT CHARACTERISTICS:

Mechanical: Same as 1430A.

Electrical: Same as 1430A except reflection from sampler is approximately 5%, using a 40-ps TDR system.

PHASE SHIFT BETWEEN CHANNELS: Less than 10 $^\circ$ at 5 GHz, typically less than 2 $^\circ$ at 1 GHz.

CONNECTING CABLE LENGTH: 5 ft. (10 ft. optional).

PRICE: \$3000 (\$3035 with 10-ft. cable).

MODEL 1432A SAMPLER

(used with 1411A)

RISE TIME: Less than 90 ps.

BANDWIDTH: dc to 4 GHz.

OVERSHOOT: Less than \pm 5%.

DYNAMIC RANGE: \pm 1 V.

INPUT CHARACTERISTICS:

Mechanical: GR Type 874 connectors used on input and output.

Electrical: 50 Ω feedthrough, dc coupled. Reflection from sampler is approximately 15% using a 90-ps TDR system.

TIME DIFFERENCE BETWEEN CHANNELS: Less than 25 ps.

CONNECTING CABLE LENGTH: 5 ft. (10 ft. optional).

PRICE: \$1000 (\$1035 with 10-ft. cable).

MODEL 1424A SAMPLING TIME BASE

SWEEP RANGE: 24 ranges, 10 ps/cm to 500 μ s/cm. Sweeps from 1 ns/cm to 500 μ s/cm may be expanded up to 100 times and read out directly.

MARKER POSITION: Intensified marker indicates point about which sweep is expanded; 10-turn, calibrated control.

TRIGGERING: (Less than 1 GHz.)

Internal (with 1410A):

Automatic:

Pulses: 75 mV amplitude for pulses 2 ns or wider for jitter less than 20 ps.

CW: 25 mV amplitude from 60 Hz to 500 MHz for jitter less than 10% of input signal period. (Usable to 1 GHz with increased jitter.)

Level Select:

Pulses: 35 mV amplitude for pulses 2 ns or wider for jitter less than 20 ps.

CW: 25 mV amplitude from dc to 300 MHz (increasing to 200 mV at 1 GHz) for jitter less than 1% of input signal period + 10 ps.

External:

Automatic:

Pulses: At least 100 mV amplitude for pulses 2 ns or wider for jitter less than 20 ps.

CW: 50 mV from 60 Hz to 500 MHz for jitter less than 10% of input signal period. (Usable to 1 GHz with increased jitter.)

Level Select:

Pulses: At least 50 mV amplitude required of pulses 2 ns or wider for jitter less than 20 ps.

CW: 50 mV from dc to 1 GHz for jitter less than 1% of input signal period + 10 ps. Jitter is less than 30 ps for signals of 10 mV at 1 GHz.

Slope: Positive or negative.

External Trigger Input:

50 Ω , ac or dc coupled.

Jitter: Less than 10 ps on 1 ns/cm range, and less than 20 ps (or 0.005% of unexpanded sweep speed, whichever is larger) at 2 ns/cm and slower, with signals having rise times of 1 ns or faster.

TRIGGERING: (Greater than 1 GHz.)

Jitter less than 20 ps for 25 mV input, 500 MHz to 5 GHz.

SCANNING:

Internal: X axis driven from internal source. Scan density continuously variable.

Manual: X axis driven by manual scan control knob.

Record: X axis driven by internal slow ramp; approximately 60 seconds for one scan.

External: 0 to +15 V required for scan; input impedance, 10 k Ω .

Single Scan: One scan per actuation; scan density continuously variable.

SYNC PULSE OUTPUT:

Amplitude: Greater than 1.5 V into 50 Ω .

Rise Time: Approximately 1 ns.

Overshoot: Less than 5%.

Width: Approximately 1 μ s.

Relative Jitter: Less than 10 ps.

Repetition Rate: One pulse per sample.

PRICE: \$1200.

MODEL 1425A SAMPLING TIME BASE AND DELAY GENERATOR

MAIN SWEEP:

Range: 13 ranges, 1 ns/cm to 10 μ s/cm.

Magnifier: 7 calibrated expansion ranges, X1 to X100. Increases fastest calibrated sweep speed to 10 ps/cm. Pushbutton returns magnifier to X1.

Magnified Position: 10-turn control with intensified marker that indicates sweep expansion point.

TRIGGERING: (For both Main and Delaying Sweep.)

Internal:

Automatic:

Pulses: 150 mV amplitude for pulses 2 ns or wider for jitter less than 20 ps.

CW: 50 mV amplitude from 200 Hz to 500 MHz for jitter less than 10% of input signal period. (Usable to 1 GHz with increased jitter.)

Level Select:

Pulses: 70 mV amplitude for pulses 2 ns or wider for jitter less than 20 ps.
CW: 50 mV amplitude from 200 Hz to 300 MHz (increasing to 400 mV at 1 GHz) for jitter less than 1% of input signal period + 10 ps.

External: Same as 1424A, except low end of CW triggering range is 200 Hz in Automatic and Level.

External Trigger Input:

50 Ω ac coupled (2.2 μ F).
Slope: Same as 1424A.
Jitter: Same as 1424A.

DELAYING SWEEP:

Range: 15 ranges, 10 ns/cm to 500 μ s/cm.
Delay Time: Continuously variable from 50 ns to 5 ms.

SWEEP FUNCTIONS: Main sweep, delaying sweep, main sweep delayed.

SCANNING: Same as 1424A except no external scan input.

SYNC PULSE OUTPUT: Same as 1424A. Pulse always synchronized to main sweep trigger circuit; pulse delay and rate are variable.

PRICE: \$1600.

**18-GHz TRIGGER COUNTDOWN
MODEL 1104A COUNTDOWN SUPPLY
MODEL 1106A TUNNEL DIODE MOUNT**

INPUT:

Frequency Range: 1 GHz to 18 GHz.
Sensitivity: Signals 100 mV or larger, and up to 12.4 GHz, produce less than 20 ps of jitter (200 mV required to 18 GHz).
Input Impedance (1106A): 50 Ω Amphenol GPC-7 input connector. Reflection from input connector is less than 10% using a 40-ps TDR system.

OUTPUT:

Center Frequency: Approximately 100 MHz.
Amplitude: Typically 150 mV.

PRICE: 1104A, \$200; 1106A, \$550.

20-ps PULSE GENERATOR

**MODEL 1105A PULSE GENERATOR SUPPLY
MODEL 1106A TUNNEL DIODE MOUNT**

OUTPUT:

Rise Time: Approximately 20 ps. Less than 35 ps observed with -hp- Model 1411A/1430A 28-ps Sampler and -hp- Model 909A 50 Ω termination.
Overshoot: Less than $\pm 5\%$ as observed on 1411A/1430A with 909A.
Droop: Less than 3% in first 100 ns.
Width: Approximately 3 μ s.
Amplitude: Greater than +200 mV into 50 Ω .
Output Characteristics (1106A):
Mechanical: Amphenol GPC-7 precision 7 mm connector.
Electrical: dc resistance — 50 Ω $\pm 2\%$.
Source reflection — less than 10%, using a 40-ps TDR system. dc offset voltage — approximately 0.1 V.

TRIGGERING:

Amplitude: At least ± 0.5 V peak required.
Rise Time: Less than 20 ns required. Jitter less than 15 ps when triggered by 1 ns rise time sync pulse from 1424A or 1425A Sampling Time Base. Jitter increases with slower trigger rise times.
Width: Greater than 2 ns.
Input Impedance: 200 Ω , ac coupled through 20 pF.
Repetition Rate: 0 to 100 kHz; free runs at 100 kHz.

PRICE: 1105A, \$200; 1106A, \$550.

Prices f.o.b. factory
Data subject to change without notice

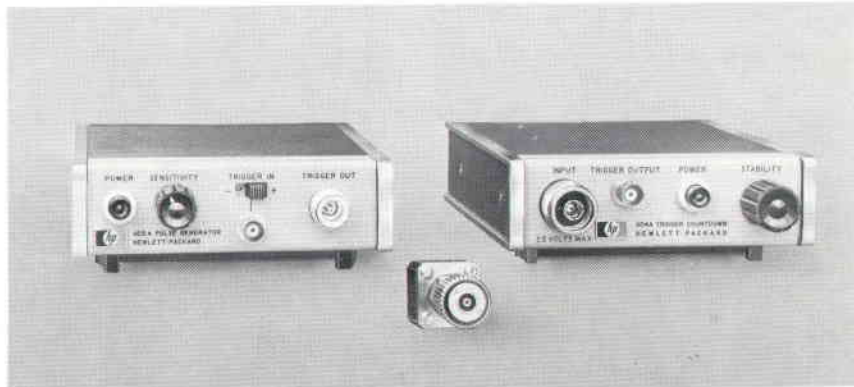

Fig. 1. Tunnel diode mount, -hp- Model 1106A, c., and pulse generator supply, -hp- Model 1105A, l., form pulse generator with rise time of approximately 20 ps, one of fastest in existence, useful for high-resolution TDR work. Same tunnel diode mount is used with countdown supply, -hp- Model 1104A, r., to allow new sampling plug-ins to display sine waves up to 18 GHz.

ULTRA-FAST TRIGGERING AND ULTRA-RESOLUTION TDR

To take full advantage of the 12.4-GHz bandwidths of the wide-band oscilloscopes described in the preceding article, it is naturally necessary to synchronize the oscilloscope time bases to signals having frequencies of 12.4 GHz and above. Similarly, to take advantage of the 28-ps rise times of the samplers for high-resolution time-domain reflectometry (TDR), it is necessary to have a step generator which has an ultra-fast rise time less than 28 ps. A single tunnel diode mount has been developed to meet both of these needs. Used with a countdown supply, the tunnel diode permits either sampling time base to trigger on signals up to 18 GHz. Used with a pulse generator supply, the same tunnel diode produces a 3- μ s pulse with a rise time of 20 ps, fast enough to resolve cable discontinuities spaced as closely as a few millimeters. Fig. 1 is a photograph of the tunnel diode mount and the two supplies.

The pulse generator has what is probably the fastest rise time available today—so fast, in fact, that there are no instruments to measure it exactly. Twenty picoseconds is a conservative estimate. In spite of its fast rise time, however, its overshoot

is less than 5%, a remarkably small value for such a fast pulse. With the 28-ps sampling oscilloscope, the pulse generator forms a time domain reflectometer with a rise time of less than 40 ps, which is about the time it takes for light to travel $\frac{1}{2}$ in. in air. Fig. 2 is a TDR oscillogram showing reflections from a special section of air line in which the diameter of the center conductor has been reduced in three sections for demonstration purposes. Centers of the three sections are $\frac{3}{8}$ in. apart and their lengths are $\frac{1}{8}$ in., $\frac{1}{4}$ in., and $\frac{1}{2}$ in. All three sections show up clearly and are readily resolvable.

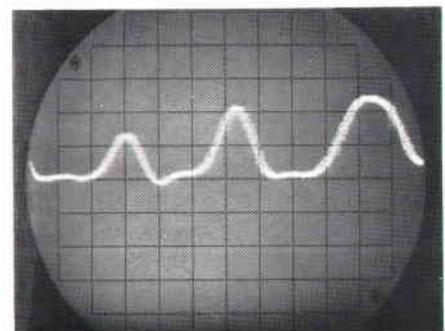

Fig. 2. Oscilloscope taken with 40-ps TDR system showing reflections from short length of line with three discontinuities. TDR system can resolve discontinuities spaced as closely as $\frac{1}{4}$ in. apart.

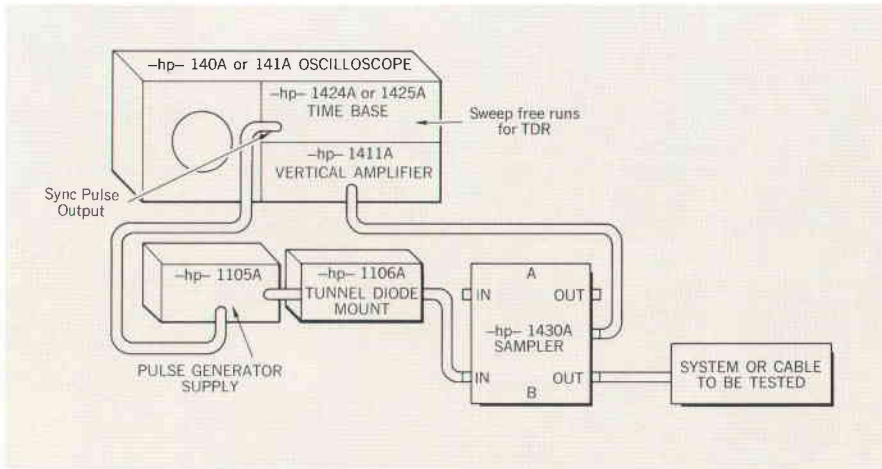

Fig. 3. 40-ps TDR system, using -hp- Model 1105A/1106A 20-ps Pulse Generator. Capabilities of system are shown by Fig. 2.

Fig. 3 is a block diagram of the 40-ps TDR system. Notice that the time base of the oscilloscope is allowed to free run, and the pulse generator is triggered by the sync pulse output of the time base. Fig. 4 shows a typical step response for this TDR system. Rise time is about 35 ps.

A typical tunnel-diode characteristic is shown in Fig. 5. In the 20-ps

pulse generator, the diode is originally biased at point A on this curve. The trigger causes the diode current to rise above point B, moving the diode into its negative-resistance region B-D. The operating point then jumps very rapidly to point C, producing the 20-ps pulse. Fig. 6 shows the output waveform.

The 18-GHz countdown unit de-

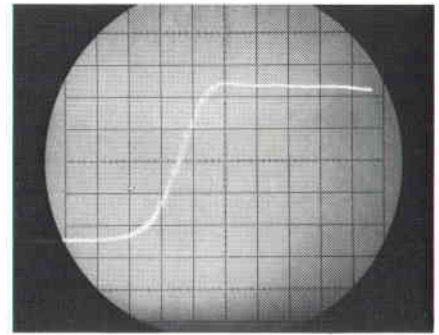

Fig. 4. Response of sampler to incident step in TDR System of Fig. 3. Typical rise time is less than 35 ps. Vertical: reflection coefficient = 0.2/cm; Horizontal: 20ps/cm.

livers a subharmonic of the input signal to the time base. Center frequency of the countdown output is 100 MHz.

For the 18 GHz countdown unit, the tunnel diode is biased at a point slightly above point B in Fig. 5, where it is astable. Its free-run rate varies, becoming a subharmonic of any high-frequency input signal.

SAMPLING UNITS DESIGN TEAM



Contributors to development of new sampling vertical amplifier and time base plug-ins and new pulse generator and countdown are, front row, l. to r., Norman L. O'Neal, Allan I. Best, James N. Painter, Edward J. Prijatel, W. A. Farnbach, James M. Umphrey; back row, l. to r., Robert B. Montoya, Gordon A. Greenley, Jeffrey H. Smith, Howard L. Layher, Jay A. Cedarleaf, all of the -hp- Colorado Springs Division. Not shown: Donald L. Gardner.

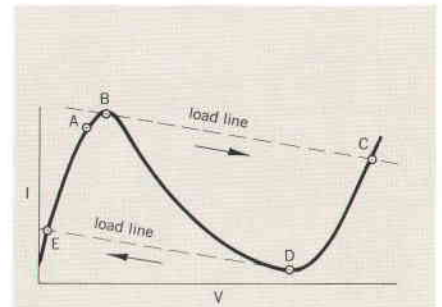

Fig. 5. Typical tunnel diode characteristic, showing negative-resistance region BD. To generate pulse with 20-ps rise time, diode is biased at A. Trigger input raises diode current to unstable point B. Operating point then shifts rapidly to C, giving fast pulse as shown in Fig. 6.

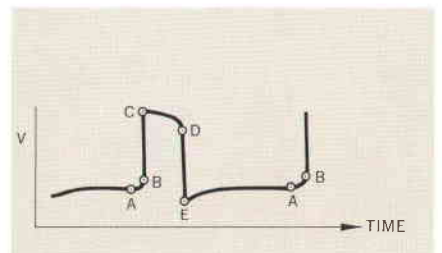

Fig. 6. Waveform corresponding to operating point sequence of Fig. 5.

SECOND SYMPOSIUM ON TEST INSTRUMENTATION

Over 150 managers of standards and calibration laboratories and instrument maintenance facilities attended the Hewlett-Packard Second Symposium on Test Instrumentation in Science and Industry. The managers, representing large and small companies and government agencies throughout the United States and Canada, met at the -hp- Palo Alto plant September 19 through 21, 1966. Purpose of the symposium was to discuss ideas and problems of mutual interest in the metrology

and instrument fields. A series of seminars, panel and round table discussions covered



Effects of increased demands for improved performance, reliability and maintainability as well as ways to meet government reliability needs were discussed at this Symposium panel session by Marco Negrete, -hp- Loveland Division, J. P. McKnight, Litton Industries, W. L. Crispin, General Electric and Robert Rupkey, TRW Systems.

topics such as calibration traceability, technical education and data processing. Some typical

sessions included in the three-day meeting were: 'Let's Define Accuracy,' treating the seriousness of certification and traceability; 'Centralization of Test Equipment,' a discussion of the pros and cons of the instrument pool; 'Automatic Data Processing,' that is, how to make your company computer work for you; and 'What Will Instruments Be Like Five Years From Now,' discussing integrated circuits; programmable instruments and data acquisition systems.

NEW NBS LABORATORIES

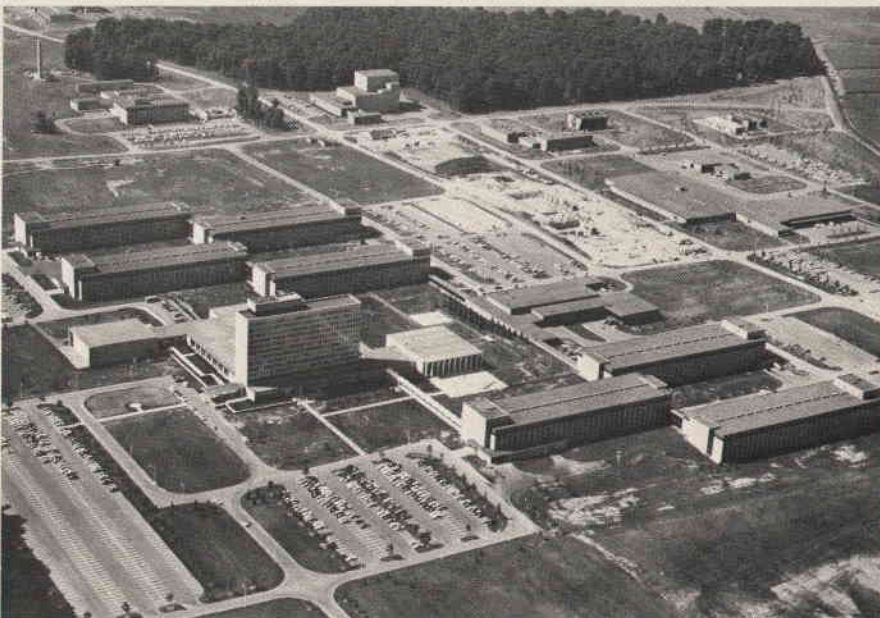

The National Bureau of Standards will dedicate its new laboratory complex at Gaithersburg, Md. on November 15. This 565-acre site, 20 miles from the old NBS location in the District of Columbia presently contains seven general-purpose laboratories connected by all-weather passageways. Five more laboratories are to be constructed in the future for specialized uses. The laboratory buildings are dominated by an 11-story administration building which houses the Director and his staff. Included on the site are a 750-seat auditorium and a 126,000-volume library. By the end of 1966 all but about 300 of the Bureau's 2700 employees will be at the new site. The Weather Bureau's Environmental Sciences Services Administration (ESSA) will occupy the vacated NBS facilities.

A DC TO 12.4 GHz FEEDTHROUGH SAMPLER FOR OSCILLOSCOPES AND OTHER RF SYSTEMS

An important circuit development in the form of an ultra-wideband sampling device is leading to major new capabilities in electronic instrumentation.

DESPITE its relatively recent appearance, the diminutive object on this month's cover has already had considerable impact on high-frequency electronic instrumentation, and is likely to have an increasing effect in the future. The object is an ultra-wideband sampling device developed by *hp associates* and now used in such diverse broadband systems as sampling oscilloscopes (see p. 2), phase-locked automatic transfer oscillators, and vector measurement systems.¹ Bandwidth of the device is specified as greater than 12.4 GHz, more than three times the bandwidth of any previous sampling device.

High-frequency sampling techniques make possible many broadband systems, including those just mentioned, that would not be feasible otherwise.

¹The Impact of Ultra-Wideband Sampling and Associated Developments on Electronic Instrumentation, Session 23, Western Electronic Show and Convention, August 26, 1966.

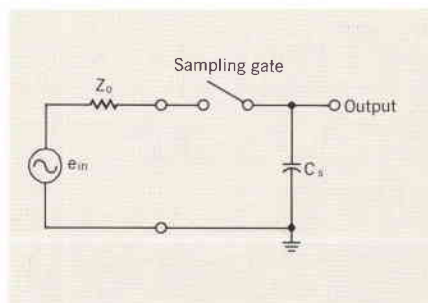
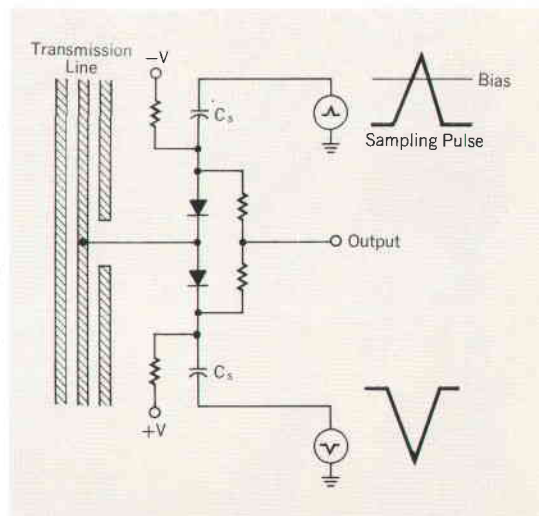

Fig. 1. Idealized sampling circuit. System to be sampled is represented by voltage e_{in} and impedance Z_0 . Sample is taken by closing gate for short period, allowing sampling capacitor C_s to charge to fraction of e_{in} . Sample is stored on C_s when gate is opened.

Fig. 2. In two-diode feedthrough sampling circuit used in wideband sampling device, normally back-biased diodes are gated on by sampling pulses for short periods, allowing sampling capacitors C_s to acquire voltages proportional to signal appearing on transmission line.



The systems which use sampling techniques are quite varied, but it is significant that the requirements for broadband sampling devices are nearly the same regardless of the application. Consequently, the use of the new sampling device in RF instrumentation is not limited to any specialized class of instruments, and will in all likelihood spread to systems which are not now thought of as sampling systems and to other RF systems which have yet to be conceived.

Development of the wideband sampling device required a large investment in time, funds, and engineering ingenuity. So that nothing would be overlooked which might aid—or frustrate—the development effort, a design approach was taken which can be best described as 'functionally integrated'.²

²The words 'functionally integrated' should not be confused with monolithic integrated circuit technology. There are no integrated circuits in the sampling device.

This means that the effects of every element of the sampling device on every other element were considered in the design, including the effects of parasitic elements and the practical considerations of cost, manufacturability, and repairability. From this approach has come a device which embodies sophisticated microwave system design and advanced diode design and packaging.

SAMPLER OPERATION

The basic elements of a sampling circuit are shown in the idealized circuit of Fig. 1. In this diagram, the system to be sampled is represented by a voltage generator e_{in} and an impedance Z_0 , and the sampler consists of a sampling gate and a sampling capacitor C_s . When a sample is to be taken, the switch or gate is closed for a short period, allowing the sampling capacitor C_s to charge

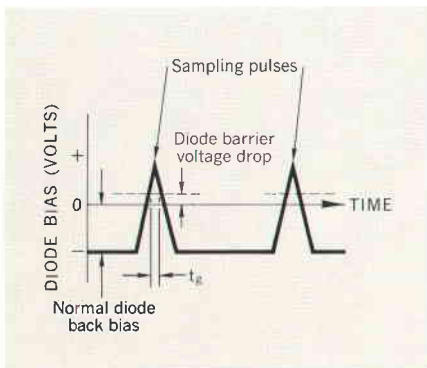

Fig. 3. Gate time t_g is time for which impedance of diodes is low in circuit of Fig. 2. Gate time is inversely proportional to bandwidth of sampling circuit. Note that gate time can be less than rise time of sampling pulse. In wideband sampling device, t_g is less than 28 ps, equivalent to bandwidth of more than 12.4 GHz.

to some fraction of the input voltage e_{in} . The switch is then opened, leaving the sample of the input stored on C_s .

If the voltage on C_s is assumed to be reset to zero before each new sample, a useful measure of the efficiency of the circuit is the sampling efficiency η , defined as the ratio of the voltage on C_s after each sample, e_{sample} , to the input voltage, e_{in} :

$$\eta = \frac{e_{sample}}{e_{in}}$$

Bandwidth of the sampler is defined as the frequency at which η is $1/\sqrt{2}$ times its dc or low-frequency value.

The new wideband sampling device is a realization of the basic two-diode feedthrough sampling circuit of Fig. 2. Signals to be sampled appear between the center and outer conductors of the feedthrough transmission line.

The diodes, which act as the sampling gates, are normally back biased. When a sample is to be taken, the diodes are gated on by balanced sampling pulses, thereby providing a low impedance path through the diodes and the sampling capacitors C_s to ground. Bandwidth of this circuit is inversely proportional to the time for which the diode impedance is low. This time interval, called the gate width t_g , is related to the bandwidth BW approximately by the formula

$$BW(\text{GHz}) \cong \frac{350}{t_g(\text{ps})}$$

A bandwidth of 12.4 GHz corresponds to a t_g of approximately 28 picoseconds. When the sampler is used in a sampling oscilloscope like the one described in the article beginning on p. 2, the rise time of the oscilloscope is also approximately equal to the gate width. Fig. 3 shows the relationships of the gate width to the sampling pulse, the diode bias, and the diode voltage drop.

WIDEBAND SAMPLING DEVICE

As a result of the 'functionally integrated' design approach which produced it, no part of the wideband sampling device has only a single function; all parts work together in such a way that the device must be considered as a whole in order to be understood. All elements, including parasitics, have been accounted for and, where possible, made integral parts of the sampling circuit. A number of normally separate parts have been combined to form unified parts, and two of the sig-

nals present — the input signal and the sampling pulses — occupy the same transmission line without interfering with each other.

Fig. 4 is a drawing of the wideband feedthrough sampling device. The device consists of a two-diode sampler located at the center of a biconical cavity which forms a part of the RF transmission line. To make room for the diodes, the two cone-shaped faces of the cavity are truncated. The RF line is perpendicular to the axis of the cones, and the sides of the cavity act as the RF ground conductor. The RF center conductor passes through the center of the cavity, and the two diodes are placed in contact with it. The characteristic impedance of the RF line is maintained at 50Ω throughout the sampling structure, the only discontinuity being a portion of the diode capacitance at the sampling node.

The diodes are specially designed low-storage hot-carrier diodes in low-

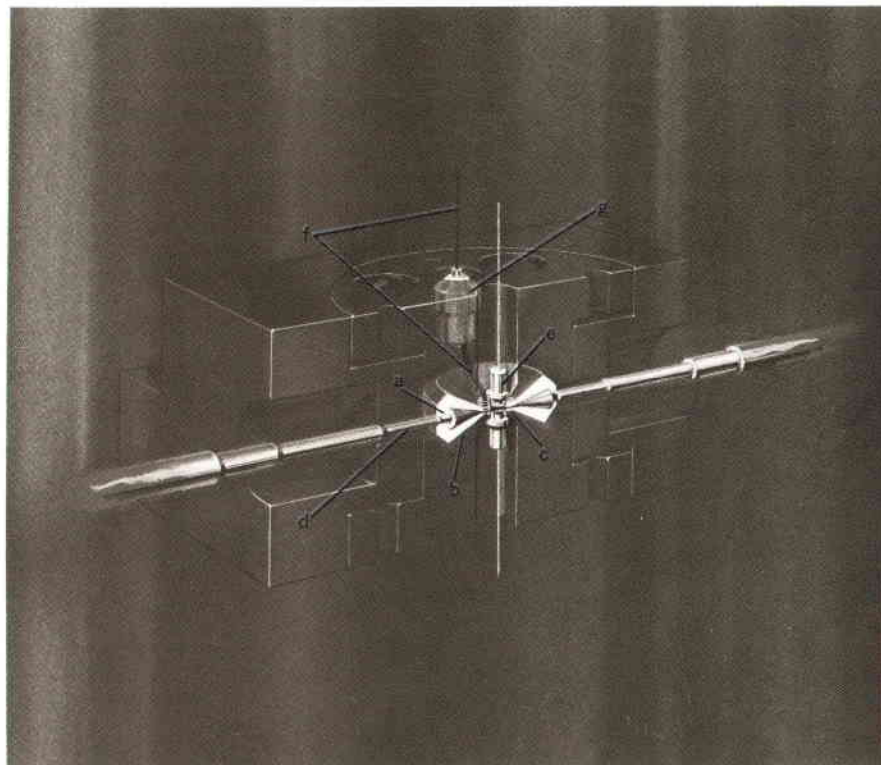

Fig. 4. Cutaway drawing of wideband sampling device. (a) dielectric-filled biconical cavity, (b) cone-shaped face of cavity, (c) top of truncated cone, (d) RF center conductor, (e) hot-carrier diode and sampling capacitor in three-terminal package, (f) sampling pulse input line, (g) plug (non-functional).

capacitance, low-inductance, three-terminal packages. The diodes and their packages embody a number of noteworthy features.

1. An advanced diode fabrication technique using an extremely small semiconductor chip. One benefit is a chip with a remarkably small capacitance of less than 0.08 pF.
2. A diode package with a series inductance of less than 200 pH and an unusually low package capacitance of approximately 0.08 pF. The insulating portion of the diode package is made of a material which has a low dielectric constant; this lowers the package capacitance and helps prevent this capacitance from reducing bandwidth, as described next.
3. A three terminal diode package with a built-in sampling capacitor. Having the sampling capacitor an integral part of the diode package not only reduces lead

inductances, but also relocates the diode package capacity so that it appears across the RF line instead of in parallel with the diode chip. This means that the package capacity can be partially masked (i.e., made an integral part of the RF line) by filling the cavity with a dielectric which has approximately the same dielectric constant as the package material.

Design of the cavity was complicated by the requirement of minimum inductance between the ground of the RF line at the sampling axis and the ground points of the sampling capacitors. This inductance was eliminated by splitting the ground conductor of the RF line and making the RF and sampling-capacitor ground points physically the same point (AA' in Fig. 5). This technique is basic to the operation of the device and plays a key role in the reduction of sampling circuit inductance which would otherwise limit the bandwidth.

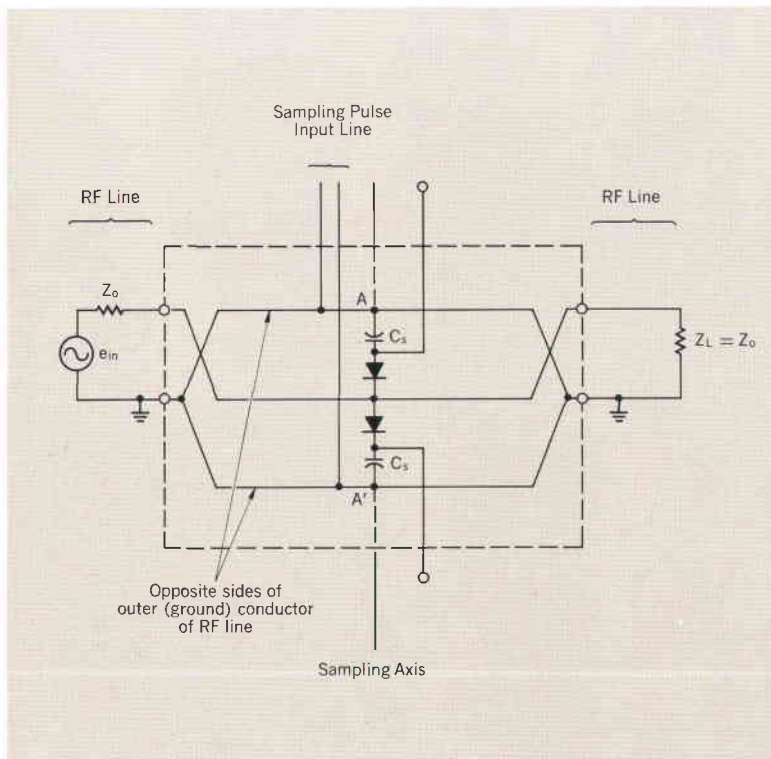

Fig. 5. Bandwidth-limiting inductance between sampling-capacitor ground points and RF ground at sampling axis is eliminated in wideband sampling device by making these ground points (AA') coincide physically. Sampling step voltage is introduced between centers of opposite faces of biconical cavity, i.e., between opposite sides of RF ground conductor.

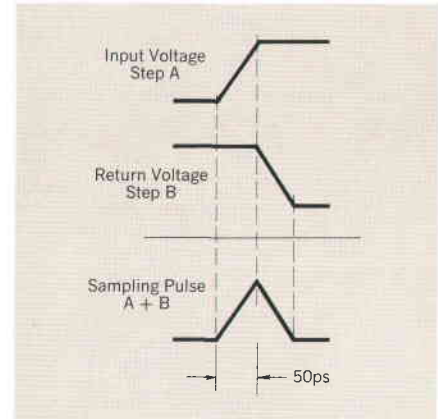

Fig. 6. Sampling signal input is voltage step which turns diodes on, then travels outwards from center of biconical cavity to short circuit at outer edges of cavity. Step is reflected at outer edges and equal and opposite step travels back to center of cavity and out sampling signal line, turning diodes off. Round trip time is 50 ps.

The split ground configuration also provides an ideal entry point for the sampling signal, since it is possible to develop a voltage (for a short time) across the impedance between the two sides of the RF ground conductor. The sampling signal enters the cavity at a point next to one of the diodes (upper diode in Fig. 4) through a section of 50-ohm microcoax transmission line. The center conductor of the sampling line continues across the cavity, contacting the opposite truncated cone face near its center. Hence, when a sample is to be taken, the sampling voltage is introduced between the centers (approximately) of the two cone faces. This means that the sampling signal appears as a potential difference between two points on the RF ground conductor, as shown schematically in Fig. 5.

A biconical cavity driven from its center has a constant characteristic impedance. To the sampling signal, the cavity appears to be a shorted section of 50-ohm line, driven from the center of the cavity and shorted at the outer edges. This shorted 'stub' is part of the network which forms the sampling pulse.

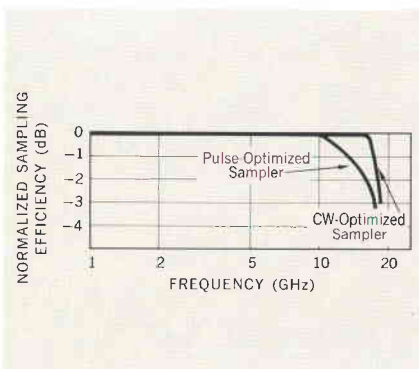

Fig. 7. Frequency response of the two types of wideband sampling devices. Bandwidths of 16 GHz are typical.

To begin the sampling process, a voltage step is introduced into the biconical cavity through the sampling pulse line. Coupling through the sampling capacitors and turning the diodes on as it enters the cavity, the step travels out towards the short circuit at the outer edges. A reflection occurs when the step reaches the short, and an equal and opposite step travels back to the center of the cavity and out the sampling line, turning the diodes off as it passes their location (see Fig. 6). The time taken by the step to travel from the center of the cavity to the outer edge and back to the center is about 50 picoseconds. However, as shown in Fig. 3, the gate width t_g can be less than 50 picoseconds because the sampling pulse does not have zero rise and fall times. In the 12.4-GHz sampler, t_g is about 28 ps.

Care has been taken to introduce the sampling signal into the cavity in such a way that the RF center conductor al-

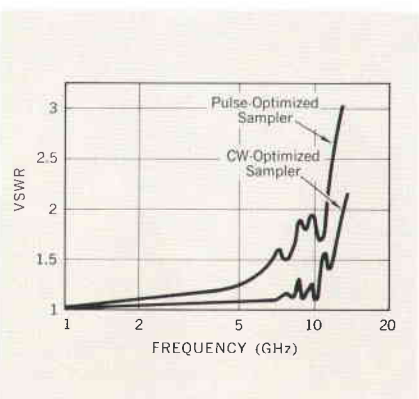

Fig. 8. VSWR of the two types of wideband sampling devices.

ways lies on an equipotential plane with respect to the sampling signal. This means that the voltage on the RF line is not affected by the presence of the sampling signal, and that the sampling signal is not affected by the presence of the RF center conductor. Although there are two modes of transmission on the RF line—the input signal and the sampling signal—these two modes are electrically isolated from each other. Typical isolation is greater than 40 dB.

PULSE AND CW SAMPLERS

While the partial masking of the diode package capacitance was a key factor in achieving the wide bandwidth of the sampling device, it was not necessary to mask totally both the package capacitance and the diode chip capacitance in order to meet the bandwidth specification. In the basic sampler, the unmasked diode capacitance at the sampling node causes the voltage standing wave ratio at the RF input to increase with frequency, approaching 3:1 at 12.4 GHz. For CW applications, which call for minimum VSWR rather than good transient response, a compensated, or CW-optimized, version of the sampler has been designed. Compensation is accomplished by incorporating the unmasked diode capacitance in a low-pass T-filter network. The filter takes the form of a modified RF center conductor in the truncated section of the biconical cavity. Measured frequency response, VSWR, and step response for both the uncompensated (pulse-optimized) and the compensated (CW-optimized) versions of the sampler are shown in Figs. 7, 8, and 9. Compensation increases the bandwidth and reduces the VSWR of the sampler to about 1.8:1 at 12.4 GHz, but causes 5 to 10% more overshoot in the step response. Notice in Fig. 7 that the 3-dB bandwidths of both samplers are considerably greater than 12.4 GHz. Typical bandwidths are now 14–16 GHz, and there is ample reason to believe that they will eventually be extended to over 18 GHz.

ACKNOWLEDGMENTS

The author wishes to acknowledge the helpful suggestions of Dr. Bernard M. Oliver, *-hp-* vice president for re-

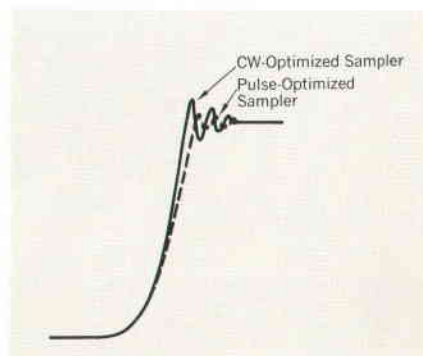

Fig. 9. Step responses of the two types of wideband sampling devices. CW-optimized sampler has wider bandwidth and lower VSWR, but has greater overshoot in step response.

search and development, and the work of the many individuals at *hp associates* who contributed to the development of the wideband sampler.

—Wayne M. Grove



WAYNE M. GROVE

Wayne Grove's first project after joining the *-hp-* Oscilloscope Division in 1961 was the design of the transistorized high-voltage power supply for the 140A Oscilloscope. Moving next into the study of high-frequency sampling techniques, he was responsible for the design and development of the 188A 4-GHz Sampling-Oscilloscope Vertical Amplifier. In 1963 Wayne joined *hp associates*, and was involved in the development of the *hpa* broadband microwave switch. He next became the design leader for the 12.4-GHz sampling device and the 1106A Tunnel Diode Mount, and contributed to the development of other microwave components including mixers and detectors. In mid-1966 he assumed his present position of research and development manager of the photoconductor department of *hp associates*.

Wayne received his BS degree in electrical engineering from Iowa State University in 1961 and his MS degree, also in electrical engineering, from Stanford University in 1963. He is a member of Tau Beta Pi, Eta Kappa Nu, Phi Kappa Phi, and IEEE. He holds several patents on wideband sampling and tunnel-diode pulsers.

A SUMMARY OF SOME PERFORMANCE CHARACTERISTICS OF A LARGE SAMPLE OF CESIUM-BEAM FREQUENCY STANDARDS

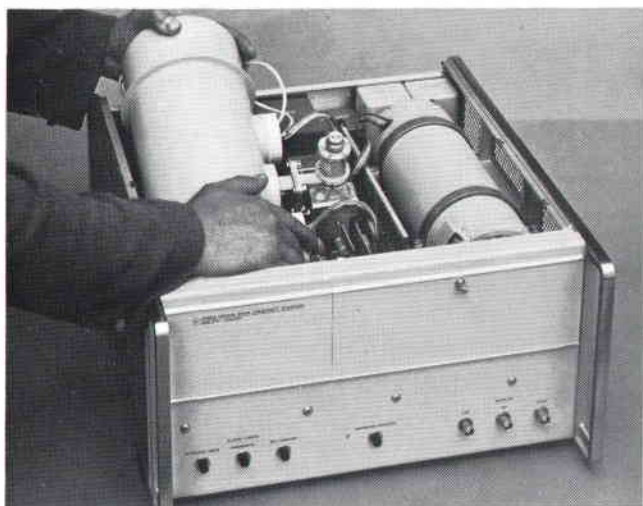

Fig. 1. Compact (16-in) cesium-beam resonator, Varian Associates BLR-3, being installed in -hp- Model 5060A Portable Cesium-Beam Frequency Standard. Resonator is world's shortest in a commercially available standard, was especially developed by Varian Associates for use in the -hp- standard.



Fig. 2. Flying Clock No. 9, based on the -hp- portable cesium standard, arrives at Oslo, Norway, during 1966 time-synchronization trip. Clock was accompanied by Ronald C. Hyatt (c.) of -hp- Frequency and Time Division.

CESIUM-BEAM standards belong to a class of frequency standards which are controlled or stabilized by the precisely known frequency of an atomic resonance. Currently, the principal members of the class of 'atomic' standards are the hydrogen and rubidium masers, and the rubidium, thallium, and cesium resonator-controlled oscillators.

About two years ago, -hp- introduced a portable frequency standard controlled by a new-generation, compact, cesium-beam resonator. The small size and low power consumption of the standard were achieved by taking advantage of the compactness of the cesium-beam tube and by employing the latest solid-state techniques and devices.

At present, cesium-beam resonators are the stabilizing elements in most of the world's official frequency standards. These resonators range in size from 'long-beam' tubes over 12 feet long to the compact resonator used in

the -hp- portable standard, which is only 16 inches long. Because the cesium-beam tube is so small, the complete portable standard occupies only $8\frac{3}{4}$ inches of a standard 19-inch rack, and is only $16\frac{3}{8}$ inches deep. It weighs just 63 pounds and requires only 50 watts of ac power, or 36 watts of battery power. Output signals of the portable cesium-beam standard are 5-MHz, 1-MHz, and 100-kHz sinusoids and a 100-kHz clock-drive signal.

About 100 of these portable cesium-beam standards are now in operation around the world. Some are serving as time standards for missile and satellite tracking, for precise mapping, for navigation, and for time synchronization; others are used as frequency standards for basic measurements, for propagation studies, for radio monitoring and transmitting, for doppler space-probe tracking, and for research.

Never before has there been such a large number of one type of cesium frequency standard in use. Producing

these units and working with them in the field has given the instrument's designers an unprecedented opportunity to gather a statistically significant body of data on the performance of a cesium beam standard. Over the past two years, data has been collected from such sources as laboratory tests, field applications, responses to user questionnaires, National Bureau of Standards calibrations, and three 'flying clock' experiments.^{1-2,3} Results show that the compact cesium-beam standard has met or exceeded its specified performance in all respects.⁴ In fact, some of the instrument's specifications have been tightened recently to reflect more closely the actual performance.

¹ L. N. Bodily, D. Hartke, and R. C. Hyatt, 'World-Wide Time Synchronization, 1966,' *Hewlett-Packard Journal*, Vol. 17, No. 12, August, 1966.

² L. N. Bodily, 'Correlating Time from Europe to Asia with Flying Clocks,' *Hewlett-Packard Journal*, Vol. 15, No. 8, April, 1965.

³ A. S. Bagley and L. S. Cutler, 'A New Performance of the 'Flying Clock' Experiment,' *Hewlett-Packard Journal*, Vol. 15, No. 11, July, 1964.

⁴ L. N. Bodily, 'Performance Characteristics of a Portable Cesium Beam Standard,' presented at the 1966 Frequency Control Symposium, Atlantic City, N.J., April 20, 1966.

Performance data that have been collected on 100 of the portable standards are focused on five factors which are generally accepted as important measures of performance for any frequency standard. These factors are:

1. accuracy
2. intrinsic reproducibility
3. reproducibility
4. frequency stability
5. reliability

In this article, performance of the portable cesium-beam standard with respect to each of these factors will be discussed separately. Furthermore, since there is no general agreement yet on precise definitions for some of these quantities, the definitions used in this article will be given where appropriate. These definitions are based upon those given by McCoubrey.⁵

ACCURACY

Accuracy of a frequency standard is the degree to which its frequency is the same as that of an accepted primary standard, or the degree to which its fre-

⁵ A. O. McCoubrey, 'A Survey of Atomic Frequency Standards,' IEEE Proceedings, Vol. 54, No. 2, February, 1966.

quency corresponds to the accepted definition.

Fig. 3 shows the results of comparisons of several independently aligned portable cesium standards with the U. S. Frequency Standard (USFS) over a two-year span. The placement of each bar indicates the mean frequency and the width of each bar indicates the precision of the measurement, estimated by the National Bureau of Standards. In all cases, the frequencies of the portable standards are within ± 5 parts in 10^{12} of the USFS. Specified accuracy of the portable standard is now ± 1 part in 10^{11} .

INTRINSIC REPRODUCIBILITY

Intrinsic reproducibility is the degree to which an oscillator will reproduce a given frequency without the need for calibrating adjustments, i.e., comparisons with a standard, either during manufacture or afterward. This quality is not a characteristic of the atomic resonance, which always has the same frequency, but of the design of the oscillator which makes use of the resonance. A device which has this quality can be built and aligned with-

out reference to any other standard, and will produce the nominal output frequency within very close limits. Therefore, intrinsic reproducibility is a measure of the ability of the oscillator to serve as a primary standard. The intrinsic reproducibility of cesium standards is quite high, and a long-beam cesium standard is now serving as the United States primary standard.

Fig. 4 shows the results of comparisons between 100 independently aligned cesium-beam standards and two *-hp-* house standards, which are of the same design. The frequency differences were obtained from a continuous recording of the phase difference between each test standard and one of the house standards. The average test period was 70 hours. All of the independently aligned test standards were within ± 6 parts in 10^{12} of the house standards.

REPRODUCIBILITY

Reproducibility is the degree to which an oscillator will produce the same frequency from unit to unit and from one occasion of operation to another. Included within this definition

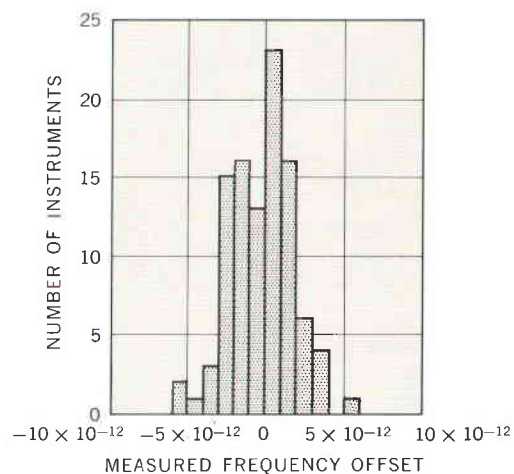
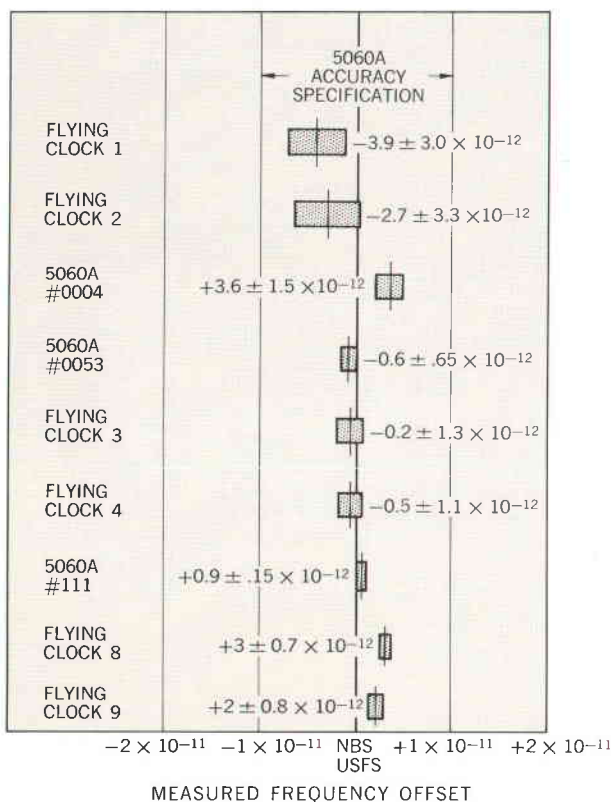

Fig. 4. (above). *Intrinsic reproducibility of portable cesium-beam standard is shown by results of comparisons of 100 independently aligned portable standards with *-hp-* house standards. All units produced same frequency within ± 6 parts in 10^{12} .*

Fig. 3. (left). *Results of frequency comparisons of several portable cesium-beam frequency standards against the U. S. Frequency Standard. Center of each bar indicates mean frequency and width of bar indicates measurement precision. Accuracy of portable standard is well within specification in all cases.*

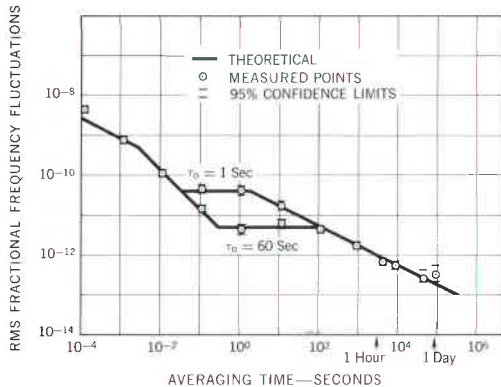

Fig. 5. Stability of mean frequency of typical portable standards having beam-tube signal-to-noise ratios of 1000:1. Solid curve shows theoretical rms frequency fluctuations as a function of time interval over which frequency was averaged. Points are measured data. Horizontal bars above and below data points show 95% confidence levels for these points. Closeness of measured points to theoretical curve indicates absence of systematic errors.

is the degree to which the frequency of an oscillator can be set by a calibration procedure. Reproducibility implies that if an oscillator is moved to another location or environment and realigned, it will produce the same frequency as before, within close limits.

One of the principal factors affecting the reproducibility of the cesium-beam standard is the precision with which the dc magnetic field within the resonator can be adjusted. Tests of the portable standard's reproducibility have included deliberate misadjustment of the internal magnetic field and realignment by eye, moving the instrument to different locations and readjusting the field, and changing the orientation of the instrument with respect to the earth's magnetic field vector and again readjusting the internal field. In all tests, the output frequency of the test standard after readjustment agreed with that of another standard within 7 parts in 10^{13} . The specified reproducibility is now ± 5 parts in 10^{12} .

FREQUENCY STABILITY

Stability is the degree to which an oscillator will reproduce the same frequency over a period of time once continuous operation has been established. A statement of the time interval used in the measurement is required.

Fig. 5 shows a plot of the magnitudes of the rms frequency fluctuations of typical portable cesium-beam stand-

ards as a function of the measurement time. The solid line is a theoretical curve calculated for the measured signal-to-noise ratios of the quartz oscillators and beam tubes in two production portable standards.⁶ Also shown are data points based upon actual frequency comparisons of the two portable standards. For the shorter measurement intervals (< 111 sec.) measurements were made by a beat frequency method that relies on period measurements.⁷ For the longer measurement times, the method used was that of successive phase differences.⁸ All of the data points are very close to the theoretical curve, indicating that systematic errors (e.g., control-loop noise) in the portable standard are quite small.

Fig. 5 also shows the effect of changing the frequency-control-loop time constant τ_0 . In the portable standard, two frequency-control-loop time constants are provided, $\tau_0 = 1$ second and $\tau_0 = 60$ seconds. The short time constant is satisfactory for timekeeping purposes and is desirable if the instrument is subjected to accelerations and motion. In a quiet environment, better short-term stability can be obtained using the long time constant.

6, 7 L. S. Cutler and C. L. Searle, 'Some Aspects of the Theory and Measurement of Frequency Fluctuations in Frequency Standards,' IEEE Proceedings, Vol. 54, No. 2, Feb., 1966.

8 D. W. Allen, 'Statistics of Atomic Frequency Standards,' IEEE Proc., Vol. 54, No. 2, Feb., 1966.



Fig. 6. Early production -hp- Model 5060A Cesium-Beam Frequency Standards were required to operate within specifications while subjected to magnetic fields up to two gauss in all orientations. Helmholtz coil was constructed to produce fields for test. Portable standard has also passed MIL-E-16400F shake and vibration test (MIL-STD-167), and exceeds the EMC (RFI) requirements of MIL-I-6181D. Production units are temperature cycled from -5°C to $+55^{\circ}\text{C}$ (operating) and are operated continuously for 15 days or more before being released.

Both the theoretical curve and the measured points in Fig. 5 are for beam tubes which have signal-to-noise ratios of 1000:1. This value is typical of most of the beam tubes now being produced.

LONG-TERM STABILITY

To test the frequency stability of the portable cesium standard over very long periods, two portable standards (the -hp- house standards) were compared over 18-month periods with signals received at Palo Alto, California from NBS standard frequency broadcasts WWVB (60 kHz) and WWVL (20 kHz). Both portable standards were independently aligned.

No drift could be detected in the frequency of either test unit over either 18-month period. It is the invariance of the cesium resonance that gives the cesium standard this long-term stability, and which makes it possible to specify that the average frequency of the portable standard will not change by more than ± 1 part in 10^{11} over the life of the cesium beam tube. Long-term stability is the quality that made possible the 'flying clock' experiments, in which clocks driven by portable cesium standards were flown around the world to synchronize the clocks at standards laboratories to within a small fraction of a microsecond. It would take these 'flying clocks' thousands of years to accumulate a time error as large as one second.

RELIABILITY

A useful measure of reliability is the mean time between major failures, or MTBF. (A major failure is one which causes the unit to fail to produce the correct, stable, output frequency.) The easiest and most realistic way to compute MTBF when sufficient data is available is to determine the actual number of operating hours logged by units in the field and divide this number by the number of major failures.

For the first time for any atomic frequency standard, enough data now exist so that the MTBF for the portable cesium beam standard can be computed by the direct method just described. Based upon warranty reports and a questionnaire sent to users, the MTBF for 78 instruments was computed to be:

MTBF for electronics only (everything except the cesium beam tube)

28,346 hours

MTBF for cesium-beam tube only

23,588 hours

MTBF for complete cesium-beam standard

13,082 hours

An MTBF of 13,082 hours means that a new instrument can be expected to operate continuously for almost 18 months, on the average, before a major failure occurs. Although this represents a high degree of reliability, considerable effort is being directed towards increasing it.

ACKNOWLEDGMENTS

It is a pleasure to acknowledge the following contributions to this article. Albert F. Augustine developed the reliability data, Ilhan M. Gozaydin performed the statistical analysis of the short-term stability data, and Rex R. Brush assisted in data assembly.

—LaThare N. Bodily

OPERATION OF THE PORTABLE CESIUM-BEAM FREQUENCY STANDARD

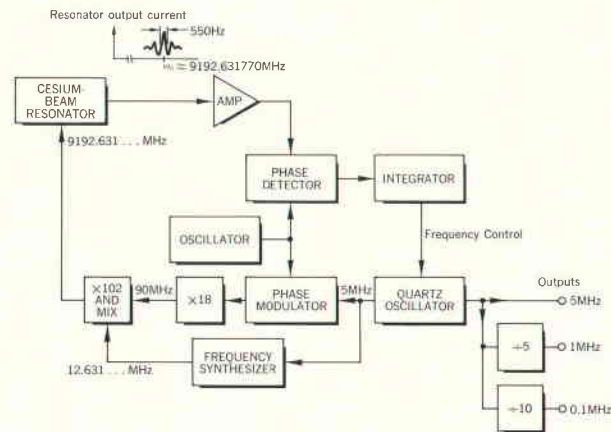

Block diagram of portable cesium-beam frequency standard.

The output frequency of the portable cesium-beam standard is controlled by a feedback loop containing a cesium-beam tube, or resonator (see block diagram). Output signals of the standard are derived from a precision 5-MHz quartz oscillator. The oscillator is capable of being operated by itself as a frequency standard, but like all quartz oscillators, it has a slight long-term drift, or aging effect. The cesium-beam resonator has negligible drift over long periods, although it has short-

term (<100 sec.) fluctuations in its output signal that are greater in relative magnitude than those of the quartz oscillator. The standard is designed so that the cesium-beam tube and the quartz oscillator complement each other, the cesium-beam tube compensating for the quartz aging effect, and the quartz oscillator acting as a 'flywheel' to reduce the short-term fluctuations of the resonator.

continued on p. 20



LATHARE N. BODILY

Lee Bodily graduated from Utah State University with an EE degree in 1956 and immediately joined —hp— as a development engineer. He later earned an MSEE at Stanford in the —hp— Honors Cooperative Program and has done further graduate study towards the degree of Electrical Engineer.

At —hp— Lee's first assignment was in the group developing the —hp— Model

560A Digital Recorder. Since that time he has been concerned with precision oscillator development, first on the time bases for the 524C/D 10-MHz Electronic Counters and then as project leader for the 100E Frequency Standard, the 101A 1-MHz Oscillator, the 106A and 107A Precision Quartz Oscillators, and the time base in the 5245L 50-MHz Counter. He developed the quartz oscillator 'flywheel' in the 5060A Cesium-Beam Frequency Standard and also contributed to the 103A and 104A Quartz Oscillator development. Since mid-1964 he has been section leader of the frequency standards group, now having responsibility for both quartz oscillator and cesium-beam frequency standard development. Lee's article in this issue is his fourth contribution to the Hewlett-Packard Journal.

HEWLETT-PACKARD JOURNAL

TECHNICAL INFORMATION
FROM THE LABORATORIES OF THE
HEWLETT-PACKARD COMPANY

VOL. 18, NO. 2  OCT. 1966

PUBLISHED AT THE CORPORATE OFFICES
1501 PAGE MILL ROAD,
PALO ALTO, CALIFORNIA 94304

Staff: F. J. Burkhard, Editor; R. P. Dolan
H. L. Roberts, L. D. Shergalis
R. A. Erickson, AD

CESIUM-BEAM FREQUENCY STANDARD

continued from page 19

Reference for the portable standard is a time-invariant quantum effect in the cesium 133 atom. In the cesium-beam resonator (see drawing), a beam of cesium atoms is generated in the cesium oven. Atoms in a particular energy state ($F = 4, m_F = 0$)* are selected by the 'A' magnet and allowed to enter the cavity to interact with the microwave field. The microwave signal is synthesized in the frequency-control feedback loop from the 5-MHz quartz oscillator signal. If the microwave frequency is $9192.631770 + 427C^2$ MHz, where C is the average resonator magnetic field in milligauss, some of the atoms will 'flip', or undergo transitions to a different energy state ($F = 3, m_F = 0$). Atoms that 'flip' are directed by the 'B' magnet to the hot-wire ionizer, where they are given a positive charge and sent back through the mass spectrometer to the electron multiplier. Beam tube output is the output current of the multiplier. This current is shown as a function of the microwave frequency in the small curve in the block diagram. Width of the central peak is 550 Hz between half-amplitude points, so the resonator has a Q of about 18 million.

The frequency-control loop tunes the quartz oscillator to keep the microwave frequency equal to the resonant frequency of the beam tube. Loop parameters are chosen so that these frequencies are equal only when the oscillator output is 5 MHz. The beam-tube resonant frequency does not change with time, so the long-term stability of the standard is very high. Moreover, final alignment of the standard (by adjusting the average magnetic field in the resonator) can be carried out without reference to any other standard, i.e., the cesium-beam standard can serve as a primary frequency standard.

* F and m_F are quantum numbers.

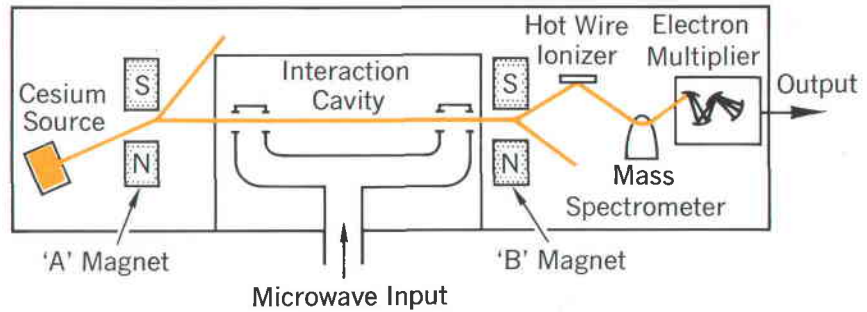

Schematic diagram of cesium-beam resonator.

FREQUENCY STANDARDS IN THE OMEGA NAVIGATION SYSTEM

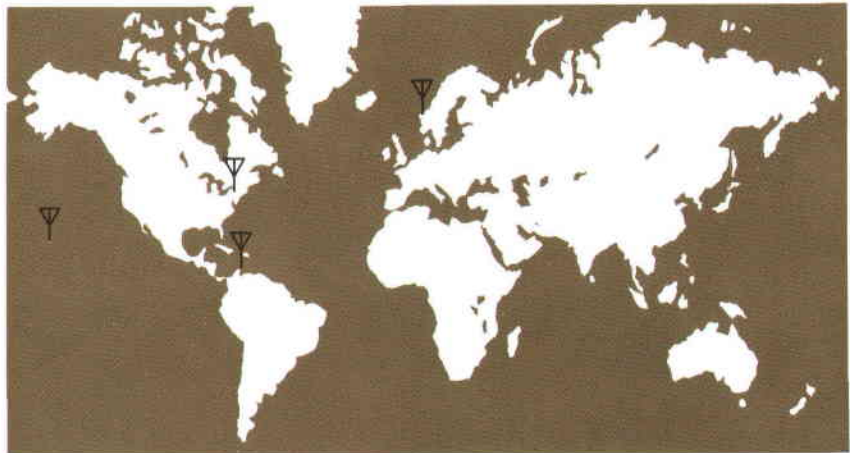

Omega is a radio aid to navigation being developed and tested by the U.S. Navy Electronics Laboratory and the U.S. Naval Research Laboratory.* Studies show that a network of eight stations, each transmitting several frequencies between 10 kHz and 14 kHz, can provide good position fixes throughout the world with rms errors of only 1 kilometer in the daytime and 2 kilometers at night. A navigator determines his position by measuring the phase differences between the transmissions of three or more stations. Four Omega stations are now operating.

* J. A. Pierce, 'Omega,' IEEE Transactions on Aerospace and Electronic Systems, Vol. AES-1, No. 3, Dec., 1965.

These are located in Norway, Trinidad, Hawaii, and New York.

Omega's accuracy depends upon how well the antenna currents of all of the stations can be kept in absolute phase with each other at all times. Synchronization of the antenna currents is achieved by equipping each station with a stable frequency source, from which the transmitted frequencies are derived. The primary frequency sources for the four existing Omega stations are ~~hp~~ portable cesium-beam frequency standards. The standards are synchronized once a day and are so stable that they accumulate less than one microsecond of phase deviations between synchronizations.

HP Archive

This vintage Hewlett-Packard document was
preserved and distributed by

www.hparchive.com

Please visit us on the web!

On-line curator: John Miles, KE5FX

jmiles@pop.net

