

HEWLETT-PACKARD JOURNAL

Cover: NEW BRIDGE WITH SEMI-AUTOMATIC TUNING, page 2
See also: MEASURING TO 12.4 GHz WITH COUNTERS, page 11
NEW FCC SPECS ON FM STEREO FREQUENCY CONTROL, page 14
CHECKING SPECTRUM ANALYZER CALIBRATION, page 15

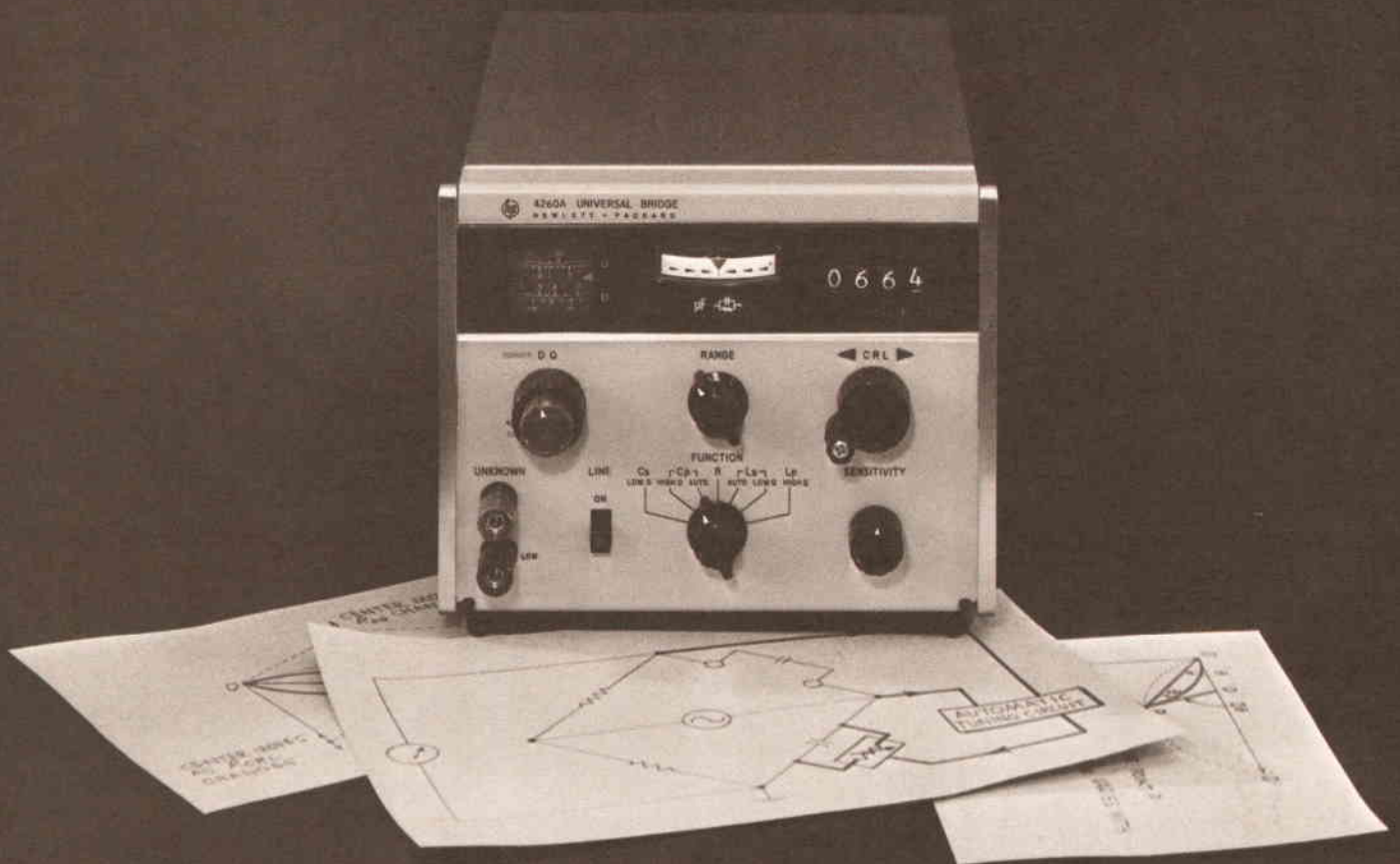

SEPTEMBER 1966

A NEW UNIVERSAL IMPEDANCE BRIDGE WITH SIMPLIFIED, SEMI-AUTOMATIC TUNING

By using feedback to adjust one bridge element automatically, a bridge requiring only one balancing control is achieved.

Universal bridges have considerable versatility, being able to measure not only resistance, capacitance, and inductance over wide ranges, but also the Q of inductances and the dissipation factor ($1/Q$) of capacitors. This versatility, however, has led to

complicated control panels, oftentimes making it not so simple for the casual user to make bridge measurements without recourse to study of the instruction manual.

A new universal bridge has been designed to remove the confusing

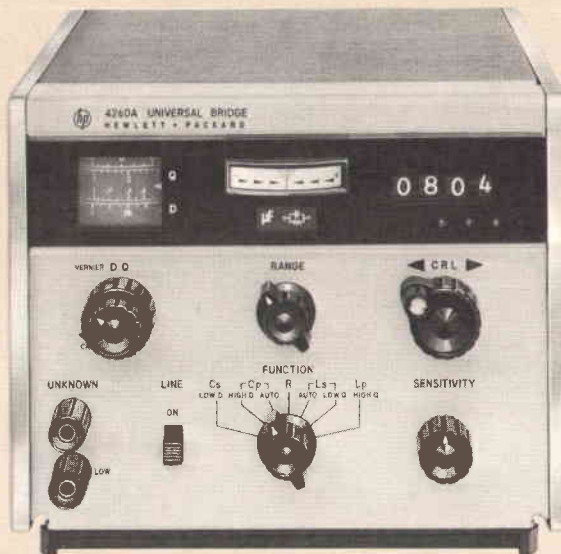

Fig. 1. New Universal Bridge has digital read-out, automatic decimal placement, non-ambiguous range indication, and other features that simplify measurement of resistance, capacitance, inductance, Q , and loss factor. Bridge design eliminates prolonged balancing procedures formerly caused by sliding null in measurements of lossy reactive components. Control circuitry automatically brings DQ resistor to correct value as CRL dial is adjusted for a null.

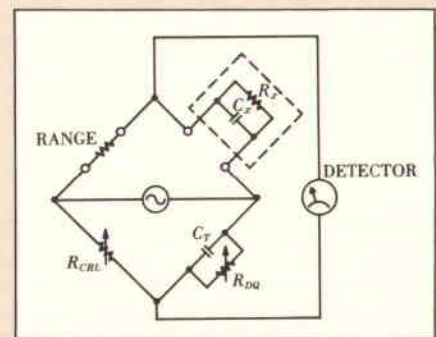

Fig. 2. Typical impedance bridge configuration, this one for measuring unknown capacitor C_x - R_x in which capacitor loss factor is considered as resistance R_x in parallel with pure capacitance C_x . Besides adjustment of R_{CRL} , R_{DQ} must be adjusted to match time constant of C_T - R_{DQ} to time constant of C_x - R_x if balance is to be achieved. R_{DQ} and R_{CRL} are interacting as far as indication on detector is concerned.

elements that have been associated with bridge operation. For example, the readout is direct. Measurement results are displayed by an in-line digital readout and the decimal point is placed automatically by the RANGE switch. The unit of measurement, as selected by the FUNCTION and RANGE switches, is shown in a window. There is no need for applying multiplication factors to the readings and, as shown by the panel arrangement in the photo of Fig. 1, there is no ambiguity in making read-

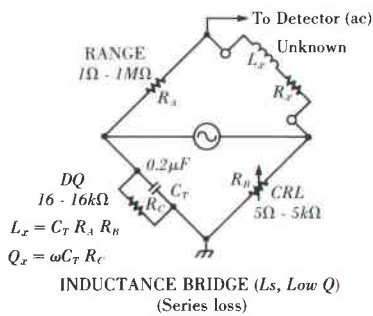
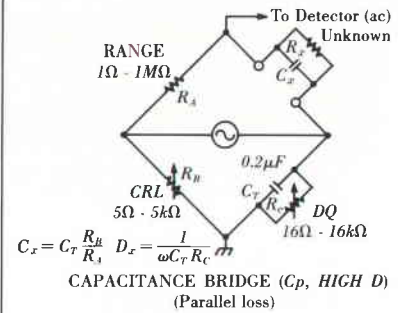
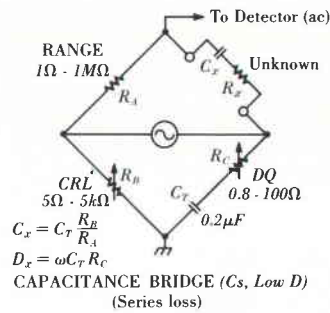
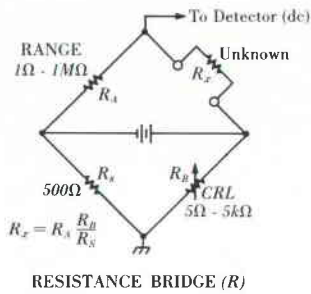
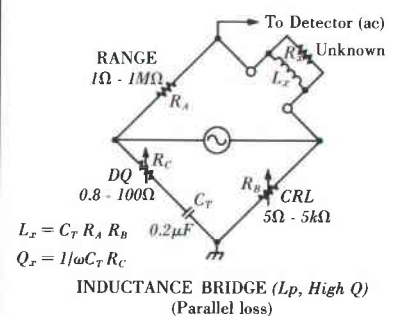

Fig. 3. Bridge circuits selected by FUNCTION switch in new Universal Bridge. In auto mode measurement of low Q or high D components, DQ resistor (R_C) is replaced by servo-controlled variable resistance.



ings of resistance, capacitance, or inductance.

As a further step toward removing confusion factors, the only terminals on the front panel of the new instrument are those for the unknown component. All other terminals, those for bias insertion and for external detectors and generators, are on the rear panel.

MEASUREMENT RANGES

The new bridge (-hp- Model 4260A) includes five bridge circuits (Fig. 3), selected by the FUNCTION switch, and necessary generators and detectors. An internal dc supply is used for measurements of resistance and an internal 1-kHz oscillator drives the bridge for measurements on capacitors and inductors. The bridge is packaged in a compact cabinet, suitable for bench use or for rack-mounting with other -hp- instruments in standard -hp- rack adapters, and it operates from ac line power.

The bridge measures resistance values from 10 milliohms to 10 megohms, inductances from 1 microhenry to 1000 henry, and capacitance from 1 pF to 1000 μF. It has seven ranges each for C , R , and L measurements. It achieves an accuracy of $\pm 1\%$ throughout the major portion of its range and at least 2% accuracy for the full range. Q is measured in two ranges, with series L and R from 0.02 to 20 and with parallel L and R from 8 to 1000. Dissipation factor D is measured in two ranges, from .001 to .12 for series C and R and from .05 to 50 with parallel C and R . The accuracy of D and Q measurements is $\pm 5\%$.

The driving oscillator within the bridge operates at 1 kHz. Other frequencies within a range of 20 Hz to 20 kHz may be used to drive the bridge, rear panel terminals enabling external oscillators and detectors to be used.

DIRECTIONAL INDICATORS

The new bridge was also designed to simplify operating procedures. During measurements of capacitance or inductance, illuminated arrows (on either side of the 'CRL' legend) show in which direction the controls should be turned to achieve balance. These indicators enable the proper range to be selected quickly and eliminate the "back-tracking" that is so often necessary when the initial setting is far off null and the meter is relatively insensitive to a change in the CRL control. The null point is indicated when the arrows switch directions.

ELIMINATION OF SLIDING NULLS

One of the major contributions towards simpler operation in the new bridge is the technique for eliminating 'sliding nulls.' In ac bridge measurements of reactive components, not only must the ac signal amplitude at the known and unknown bridge corners be equal, but the



Fig. 4. Photo shows operating features which contribute to easier bridge operation. Readout is digital and decimal point is placed automatically by RANGE switch. Window above RANGE switch shows unit of measurement for selected range and functions; circuit diagram shows whether lossy component of reactance is measured as resistance in parallel with or in series with reactance. In 'Auto' mode measurements of capacitance and inductance, illuminated arrows above CRL control indicate direction that RANGE and CRL controls should be turned to achieve null.

signals must also be in phase if a null is to be achieved. In a typical universal bridge, such as that shown in the diagram of Fig. 2, two controls (R_{CRL} and R_{DQ}) must be operated to bring the bridge into balance. These controls are interacting, particularly when lossy reactive components are being measured, and must be adjusted alternately several times, each time to bring the detector towards a new minimum, before a complete null is achieved. This multistep procedure, known as a 'sliding null,' often requires many adjustments before a true null is obtained.

The new bridge simplifies the nulling procedure by using a feedback control system to make one of the bridge adjustments automatically. To find the value of an unknown capacitance or inductance with this bridge in the 'Auto' mode, it is only necessary to adjust one control (R_{CRL}) for balance, since the other variable (R_{DQ}) is automatically brought to the correct value. C or L can then be read directly after balancing the bridge with the one adjustment of the CRL control.

Should it be desired to also find the value of dissipation factor (D)

for capacitors or quality factor (Q) for inductors, a manually-controlled potentiometer can be switched in place of the automatically-controlled resistance after the initial balance with the CRL control has been reached. The DQ control then is adjusted for a second null indication. The bridge

is thus brought to complete balance with only two adjustments.

The manually-controlled DQ dial has a cylindrical readout with four scales. To reduce the likelihood that the wrong scale may be read, a red arrow points to the scale selected by the FUNCTION switch and the value of D or Q is read directly from the scale indicated. A mechanical coupling between the RANGE and FUNCTION switches, besides displaying the selected unit of measurement in a window above the RANGE switch, also shows a circuit diagram which indicates whether the unknown component loss is being measured as a series resistance or a parallel resistance (Fig. 4). This arrangement simplifies interpretation of measurement results.

THEORY OF OPERATION

The characteristics of ac and dc bridges are thoroughly discussed in many testbooks and other reference material and need not be discussed here. Automatic control of the 'DQ' resistor, however, has not been standard practice and deserves explanation.

During measurements of C or L in the 'Auto' mode, the variable

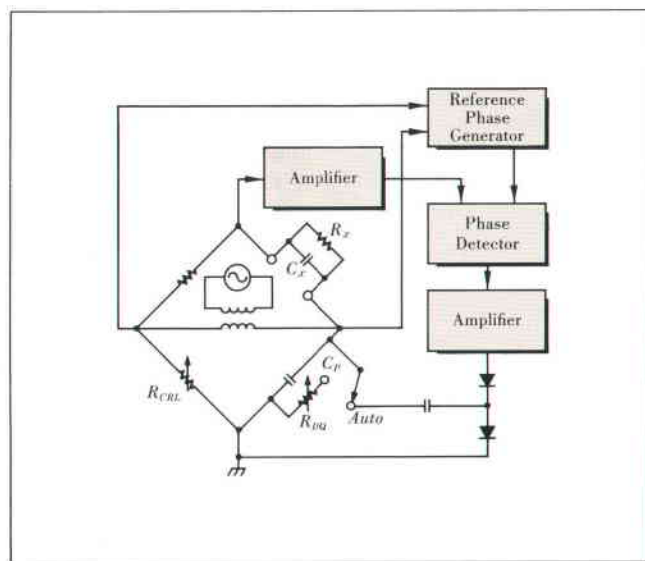

Fig. 5. Automatic control of DQ resistor is effected by phase detector which responds to phase relationship between bridge output and reference phase. Phase detector controls ac impedance of diodes, which serve as DQ resistor, by control of diode current.

resistance controlled by the DQ dial is replaced by a pair of series-connected diodes, as shown in the simplified diagram of Fig. 5. The ac resistance of the diodes can be varied from 16 ohms to a few megohms by change of the dc current through the diodes.

Diode current for control of the diode resistance is derived from the output of the phase detector, which responds to the bridge unbalance voltage. As described more fully in the article beginning on page 6, this arrangement forms an electronic servo that adjusts the diode resistance to maintain the bridge output voltage in quadrature with the reference phase. Adjustment of the CRL control can then bring the bridge directly to balance with the diode resistance automatically tracking the CRL control.

Once that balance has been achieved in the 'Auto' mode, the

operator switches the bridge out of the 'Auto' mode, which places the manually controlled ' DQ ' potentiometer (R_{DQ}) back into the circuit. Adjustment of the DQ control for a null then determines the value of D or Q .

The direction indicators are controlled by a second phase detector. It is characteristic of ac bridges that the bridge output waveform inverts as the bridge output passes through a null during adjustment of R_{CRL} . The phase detector hence can detect on which side of balance the bridge adjustment lies. The second phase detector controls a binary circuit which in turn controls the directional indicator lamps. Either one or the other of the lamps will be illuminated, depending upon which side of balance the bridge is on.

ACKNOWLEDGMENTS

The use of a photo-controlled resistor as a servo-controlled element

in an impedance bridge was suggested by John Lazier of the -hp- Advanced R and D Labs in Palo Alto and basic circuitry proving the concept was developed by Gregory Justice and Edward A. Heinsen, also of the -hp- Advanced R and D Labs. The -hp- Model 4260A Universal Bridge, based on this concept but using diodes in place of the photo-controlled resistor, was developed in the Engineering Section of Yokogawa, Hewlett-Packard, Japan. Electronic circuitry was designed by Haruo Itoh and Hitoshi Noguchi. Product design was by Kazu Suzuki and Kimijiro Kikuchi. The author wishes to express appreciation for many valuable suggestions provided by Giichi Yokoyama, Toshio Muraoka, and Yasuaki Hanatani.

— *Katsumi Yoshimoto*
Project leader

DESIGN LEADERS



HARUO ITOH



KIMIJIRO KIKUCHI



HITOSHI NOGUCHI



KAZU SUZUKI



KATSUMI YOSHIMOTO

Haruo Itoh obtained a BSEE degree from the Tokyo Institute of Technology in 1959. He then joined Yokogawa Electric Works as an R and D engineer, working on ac and dc millivoltmeters, on an RF millivoltmeter, and on an experimental clip-on ammeter that used magnetostriction.

Haruo joined Yokogawa-Hewlett-Packard in 1964, working first on improvements in a vibrating-reed electrometer and then on the design of the Model 4260A Impedance Bridge.

Kimijiro Kikuchi joined Yokogawa Electric Works in 1959 as a quality assurance engineer and transferred to -yhp- as a production engineer in 1964. A year later, he moved to the R and D

group to work on the mechanical design of the Model 4260 Bridge. Kimijiro graduated from Kurosawajiri Technical High School just prior to joining YEW.

Hitoshi Noguchi joined Yokogawa-Hewlett-Packard as an R & D engineer in 1964 and worked on the -yhp- versions of the -hp- Models 606A and 608C/D Signal Generators before being assigned to the Model 4260A Universal Bridge project. Prior to joining -yhp-, Hitoshi had been at the Yokogawa Electric Works engaged in signal generator development. He joined YEW in 1961 after earning his BSEE degree from Akita University.

Kazu Suzuki graduated from Meiji University with a BSEE degree in 1954.

He worked at Yokogawa Electric both as a manufacturing engineer and as a designer in the R and D group. Kazu transferred to -yhp- as a manufacturing engineer in 1964 and has been concerned with the mechanical and industrial design of the Model 4260A Bridge.

Katsumi Yoshimoto obtained his BSEE degree from Kyusyu University in 1958 and went to work directly for Yokogawa Electric Works, where he was involved in the development of electronic voltmeters and megohmmeters. He transferred to the Yokogawa-Hewlett-Packard Research and Development Group in 1964, initially working on the -yhp- version of the -hp- Model 428B Clip-on Milliammeter and then on the Model 4260A Universal Bridge.

A SYSTEM FOR AUTOMATIC CONTROL OF THE 'DQ' RESISTOR IN AN IMPEDANCE BRIDGE

The system for automatic control of the 'DQ' resistor in the new *hp*-Model 4260A Universal Bridge has been described briefly in the accompanying article. For the sake of clarity, the simplified description given there omitted certain details in the theory of operation, details which make the automatic system workable over a wide measurement range. This article presents a more complete description.

Since balancing an ac bridge requires adjustment of both phase and amplitude, the technique for obtaining automatic adjustment of R_{DQ} is most easily described with vector diagrams. The vector relationships for a particular set of component values in a typical bridge are shown in the diagrams of Fig. 1. The vectors are:

Vector \overline{OQ} , the bridge driving voltage, which serves as the reference vector;

Vector \overline{OS} , the voltage across the unknown component C_x - R_x ;

Vector \overline{SQ} , the voltage across RANGE resistor R_A ;

Vector \overline{PQ} , the voltage across R_{CRL} ;

Vector \overline{OP} , the voltage across C_T and R_{DQ} in parallel.

The vector voltage between points P and S in Fig. 1 represents the bridge output voltage. Point S essentially is fixed by the value of the unknown and by the setting of the RANGE switch. Point P is variable and is positioned by the R_{CRL} and R_{DQ} controls. Balancing the bridge is a process of bringing point P into coincidence with point S , effectively reducing vector \overline{PS} to zero.

Theory shows that when R_{CRL} is adjusted while R_{DQ} is held constant, the locus of point P is an arc of a circle which passes through points O and

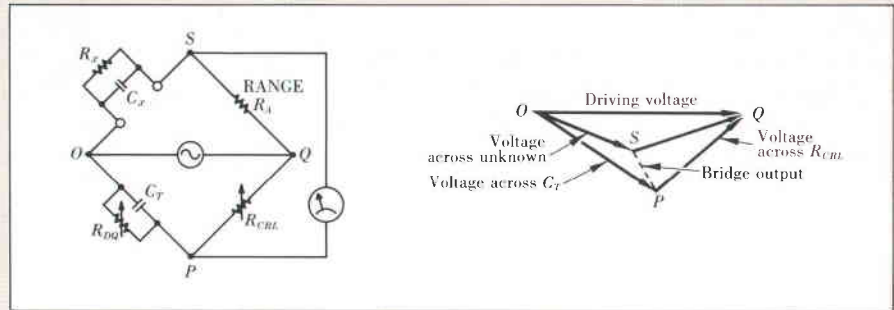

Fig. 1. Typical ac bridge and corresponding vector relationships. Vector \overline{OQ} is bridge driving voltage. Vector \overline{OS} is fixed by value of unknown component and setting of RANGE switch. Vector \overline{OP} is determined by R_{CRL} and R_{DQ} controls and C_T . Balancing bridge moves vector \overline{OP} into coincidence with vector \overline{OS} , reducing bridge output voltage \overline{PS} to zero.

Q , as shown in Fig. 2. The center of the circle is on a vertical line which bisects \overline{OQ} and the position of the center and the radial dimension depend on the ratio of X_{C_T}/R_{DQ} (see appendix).

When R_{DQ} is adjusted, while R_{CRL} is held constant, the locus of point P follows a different circular arc, also shown in Fig. 2. This circle passes through point O and its center lies on the vertical through point O . The position of the center and the radial dimension depend on the ratio X_{C_T}/R_{CRL} .

Adjustment to null, changing R_{CRL} and R_{DQ} alternately, then brings point P to point S along a curved zig-zag path such as that shown in Fig. 3.

AUTOMATIC BALANCE

To achieve automatic control of R_{DQ} , it is necessary to separate the effect of bridge unbalance caused by R_{DQ} from that caused by R_{CRL} . To see how this can be done, consider the effect of a small change in R_{DQ} . As shown in Fig. 2, a change in R_{DQ} moves point P along the arc of a circle. For a very small change, the locus

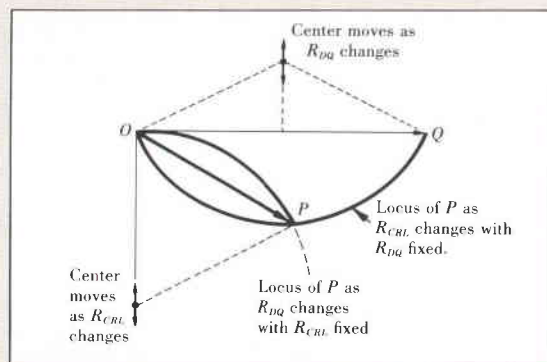

Fig. 2. Loci of head of vector \overline{OP} as R_{DQ} and R_{CRL} are adjusted independently. Each adjustment moves P along arc of circle. Parameters for each circle are changed as opposite control setting is changed.

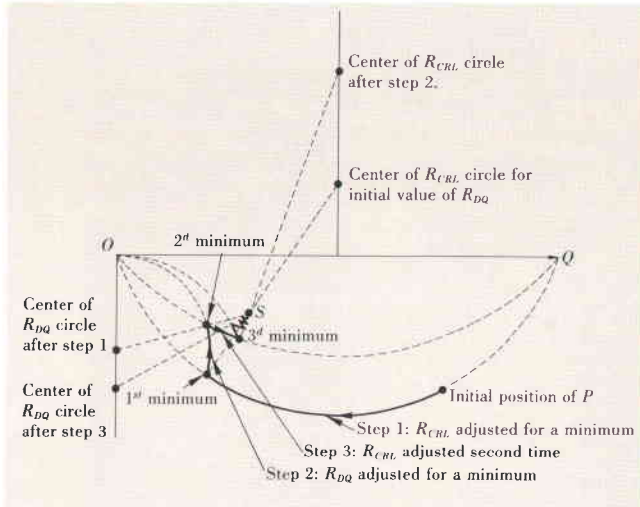

Fig. 3. Path followed by point P during bridge nulling by alternate adjustment of R_{CRL} and R_{DQ} . Each adjustment achieves minimum bridge output by moving P to line between point S and center of circle that describes locus of P during that adjustment, as shown for first four adjustments.

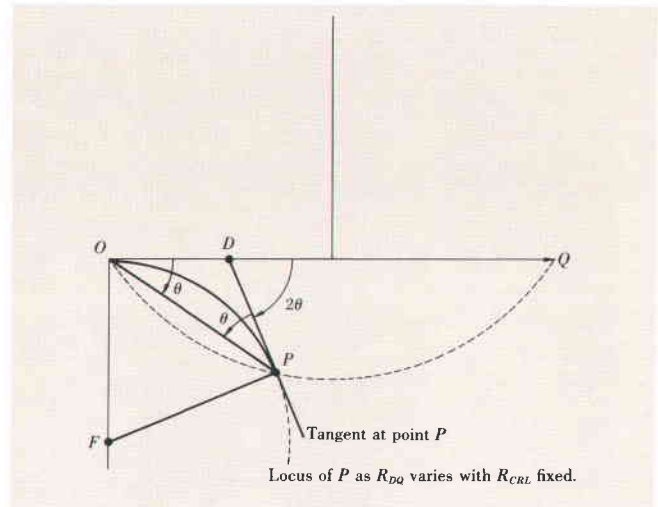

Fig. 4. Determination of phase reference for sensing change in output voltage caused by change in R_{DQ} . Small change in R_{DQ} moves P along path approximating tangent to circular locus of P . Tangent intersects reference vector \overline{OQ} at an angle 2θ that is twice angle θ made by vector \overline{OP} with respect to \overline{OQ} .

of point P may be considered as a straight line tangent to the R_{DQ} circle. A detector which senses unbalance caused by R_{DQ} hence should be sensitive to the phase of the tangent to the R_{DQ} circle at point P . It thus becomes an instrumentation problem to determine the phase of the tangent.

The geometrical construction in Fig. 4 explains how the phase angle of the tangent may be determined with respect to the reference vector \overline{OQ} . In Fig. 4, the tangent at point P is extended to the line OQ where it intersects OQ at point D . From inspection, angle $DPF = \text{angle } DOF = 90^\circ$ (F is the center of the R_{DQ} circle).

OP is a chord of the R_{DQ} circle; FO and FP are radii and are thus equal in length. Hence, the triangle OPF is isosceles.

Thus, $\angle POF = \angle OPF$,
and since $\angle DOF = \angle DPF = 90^\circ$,
therefore, $\angle DOP = \angle DPO$

We define $\angle DOP = \theta$. Hence, from the above, the tangent DP makes an angle θ ($\angle DPO$) with respect to OP . Since $\angle ODP = 180^\circ - 2\theta$, the tangent DP thus makes an angle 2θ ($\angle QDP$) with respect to OQ .

Thus it is that the bridge output resulting from a small misadjust-

ment of R_{DQ} has a phase angle 2θ with respect to the bridge driving voltage (\overline{OQ}). Therefore, to isolate the effects of unbalance caused by misadjustment of R_{DQ} , the reference for the phase-sensitive detector should have a phase equivalent to *twice the phase angle of vector \overline{OP} with respect to \overline{OQ} .*

The reference phase hence is variable. As R_{CRL} and R_{DQ} are adjusted

throughout their complete range, the full range of θ (phase angle of vector \overline{OP}) is from $16'$ to $80^\circ 58'$, as determined by the resistance range of these two controls. The reference phase 2θ would thus vary from $32'$ to $161^\circ 56'$. Hence, it would not be expected that an automatic control system for R_{DQ} using a fixed phase reference would be stable throughout the full range of the instrument.

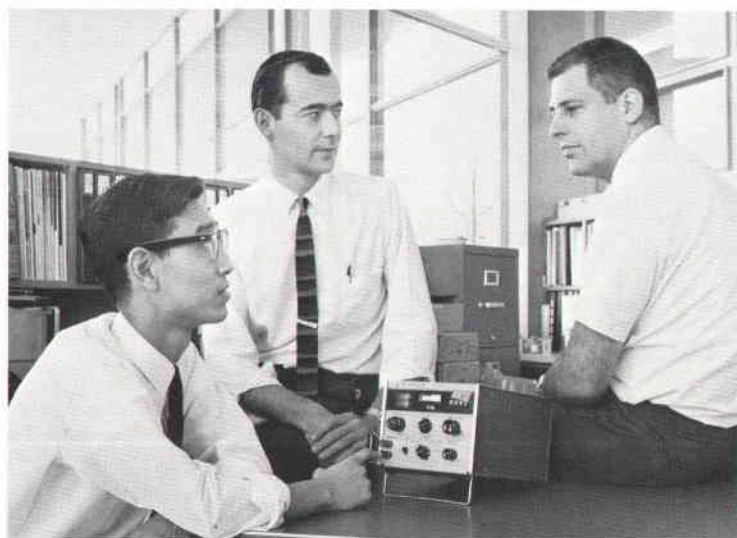

Project leader Katsumi Yoshimoto discusses design of production model instrument with Gregory Justice (center) and Edward Heinsen (right) who developed initial concept of semiautomatic bridge at -hp- Advanced R and D Laboratories in Palo Alto.

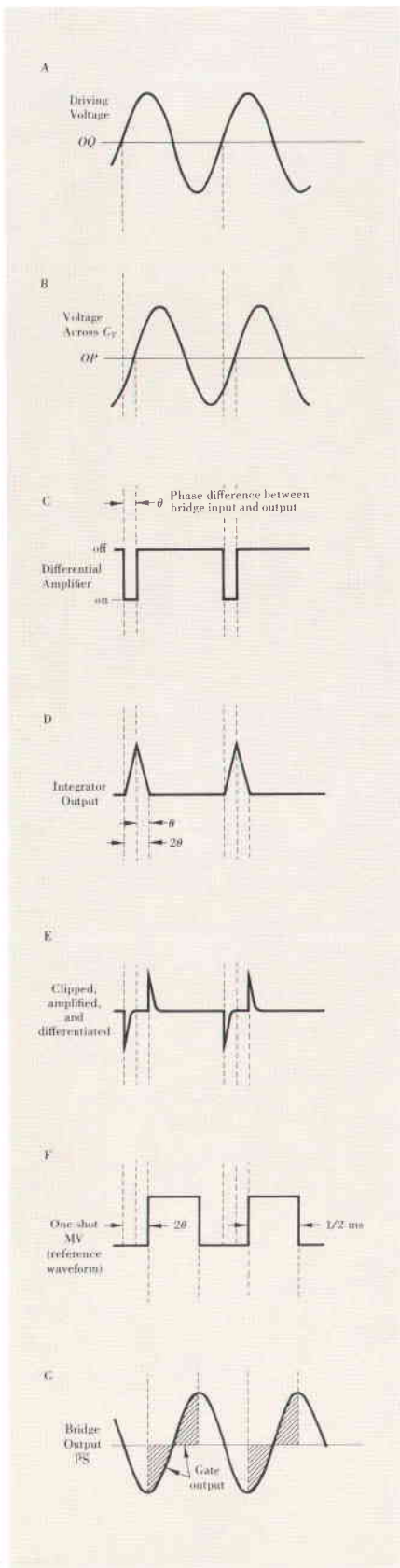
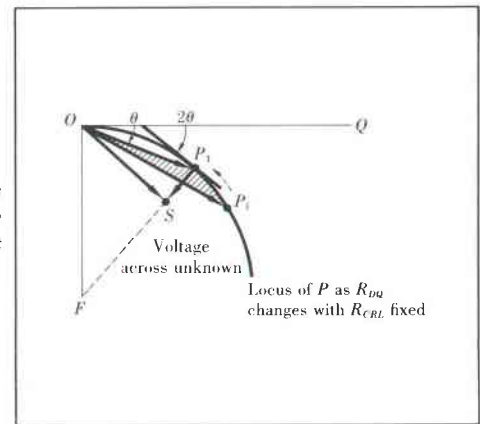

Fig. 5. Derivation of reference gating waveform phase-shifted 2θ with respect to bridge driving waveform OQ .

Fig. 6. Automatic control system moves tip of vector \overline{OP} to point P_1 where bridge output voltage $\overline{P_1S}$ is minimum for that setting of R_{CRL} .



A variable phase reference insures bridge stability while also maximizing sensitivity for the control system.

ELECTRICAL DERIVATION OF 2θ

A phase reference equal to 2θ is derived electrically in the manner illustrated in Fig. 5. The reference voltage \overline{OQ} (waveform A in Fig. 5) is amplified and clipped to a square wave and it is used to turn a differential amplifier full on (C). The voltage waveform taken across bridge arm \overline{OP} (waveform B) is likewise converted to a square wave and it is used at the other input of the differential amplifier to turn it full off. The output voltage of the differential amplifier thus is a rectangular pulse (waveform C) that has a width equivalent to the phase angle θ between \overline{OP} and \overline{OQ} .

The rectangular pulse is applied to an integrator. The integrator output is a triangular pulse that slopes up for the duration of the input pulse and which slopes down again for an equal period of time following the pulse (waveform D). The width at the base of the resulting triangle thus corresponds to 2θ .

The triangular waveform is applied to a clipping amplifier that saturates at an input voltage close to the baseline. The resulting output pulse, which has a width very nearly equal to 2θ , is differentiated (E) and the spike at the trailing edge triggers a monostable multivibrator. The output waveform (F) of the multivibrator thus has a phase delay of 2θ with

respect to the bridge driving voltage OQ .

The multivibrator has an 'On' period of 1/2 ms, and since it is triggered at a 1-kHz rate, its output is a square wave. The square wave controls a gate through which the bridge output voltage (G) is passed, and which functions as a phase detector. The smoothed output of the gate is used as the control signal for adjusting R_{DQ} .

R_{DQ} actually consists of semiconductor diodes connected in parallel with C_T . The ac impedance of these diodes can be changed from very low, with full forward bias applied, to very high with full reverse bias. The dc control system adjusts the bias on the diodes to bring R_{DQ} to a value that brings the average output of the gate (phase detector) to zero, thus reducing to zero the component of the bridge output voltage that is in phase with 2θ . The remaining component of the bridge output is a quadrature voltage that results from unbalance caused by R_{CRL} .

ORTHOGONALITY

Consider now what happens when R_{DQ} is under automatic control and R_{CRL} is adjusted. The diagram of Fig. 6 illustrates the situation when R_{CRL} is not yet brought to bridge balance. Assume that the unknown component places the tip of vector \overline{OS} at point S and that R_{CRL} and R_{DQ} initially had values such that the tip of vector \overline{OP} lies at P_1 . The automatic control system then moves the

tip of vector \overline{OP} to point P_1 , which is colinear with \overline{FS} and which thus brings vector $\overline{P_1S}$ to a minimum value. At this point, vector $\overline{P_1S}$ is orthogonal to angle 2θ . Thus, the automatic control system functions to maintain the bridge unbalance voltage orthogonal to angle 2θ , which is exactly what happens in the manual mode each time that R_{DQ} is adjusted for a minimum bridge output indication.

DIRECTIONAL INDICATORS

The 2θ square wave is also used to control the directional indicator arrows. In this case, the bridge output voltage is phase-shifted 90° , bringing it either in phase or 180° out of phase with the 2θ square wave (when R_{DQ} is under automatic control). The phase-shifted signal is then applied to a gate controlled by the 2θ square wave, the output of this gate having a positive value when the two waveforms are in phase, or a negative voltage if they are 180° out of phase. This is in contrast with the zero volts average gate output required for control of R_{DQ} .

If R_{CRL} is adjusted through a null, with R_{DQ} under automatic control, the bridge output goes to zero and

then assumes the opposite polarity on the other side of null. (This would be the case if point S were on the other side of the R_{DQ} circle in Fig. 6). Hence, the polarity of the directional control gate output depends on which side of null the bridge is adjusted.

The output of the directional control gate is applied to a circuit that drives the neon indicators. This cir-

cuit is such that either one or the other of the two neons is illuminated. The dc control voltage causes the correct arrow to be illuminated according to which side of balance the bridge is on. The cross-over is sharply defined.

— *Katsumi Yoshimoto,
Haruo Itoh, and
Hitoshi Noguchi*

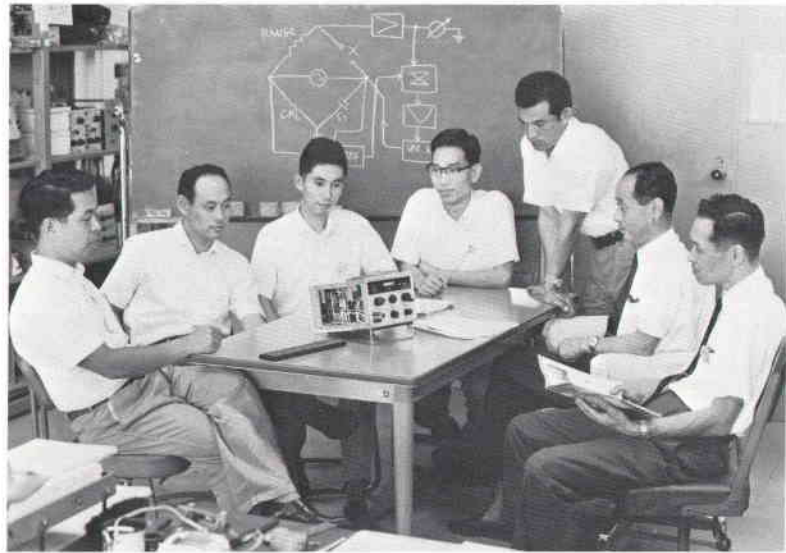

Universal Bridge design team at Yokagawa-Hewlett-Packard Co. (an international joint-venture company). From left to right, Kazu Suzuki, Horuo Itoh, Hitoshi Noguchi, Katsumi Yoshimoto, Kimijiro Kikuchi, Giichi Yokoyama, and Toshio Muraoka.

SPECIFICATIONS

—hp— MODEL 4260A UNIVERSAL BRIDGE

CAPACITANCE MEASUREMENT

CAPACITANCE

RANGE: 1 pF to 1000 μ F, in 7 ranges.

ACCURACY:

$\pm(1\% + 1 \text{ Digit})$, from 1 nF to 100 μ F.
 $\pm(2\% + 1 \text{ Digit})$, from 1 pF to 1 nF and 100 μ F to 1000 μ F.
Residual capacitance ≈ 2 pF.

DISSIPATION FACTOR

RANGE:

LOW D (series C): 0.001 to 0.12.
HIGH D (parallel C): 0.05 to 50.

ACCURACY (C greater than 100 pF):

LOW D: $\pm(5\% + 0.002)$ or one dial division, whichever is greater.
HIGH D: $\pm(5\% + 0.05)$ or one dial division, whichever is greater.

INDUCTANCE MEASUREMENT

INDUCTANCE

RANGE: 1 μ H to 1000 H, in 7 ranges.

ACCURACY:

$\pm(1\% + 1 \text{ Digit})$, from 1 mH to 100 H.
 $\pm(2\% + 1 \text{ Digit})$, from 1 μ H to 1 mH and 100 H to 1000 H.
Residual inductance ≤ 1 μ H.

QUALITY FACTOR:

RANGE:

LOW Q (series L): 0.02 to 20.
HIGH Q (parallel L): 8 to 1000.

ACCURACY (L greater than 100 μ H):

LOW Q: $\pm(5\% + 0.05)$ or one dial division, whichever is greater.
HIGH Q: $\pm(5\% + 0.002)$ or one dial division, whichever is greater.

ELECTRONIC AUTO NULL

Accuracy of CL measurements made in 3 and 4 figures (when $D \leq 1$, $Q \geq 1$) equals non-automatic measurements within $\pm 0.5\%$.

RESISTANCE MEASUREMENT

RANGE: 10 milliohms to 10 megohms, in 7 ranges.

ACCURACY:

$\pm(1\% + 1 \text{ Digit})$, from 10 ohms to 1 megohm.
 $\pm(2\% + 1 \text{ Digit})$, from 10 milliohms to 10 megohms.
Residual resistance ≈ 3 milliohms.
Resistance measurements at dc only.

OSCILLATOR AND DETECTOR

INTERNAL OSCILLATOR: 1 kHz $\pm 2\%$, 100 mV rms $\pm 20\%$.

INTERNAL DC SUPPLY: Less than 40 volts at nominal ac line voltage.

INTERNAL DETECTOR: Tuned amplifier at 1 kHz; functions as a preamplifier for measurements with external generator.

EXTERNAL OSCILLATOR: 20 Hz to 20 kHz measurements of capacitance, inductance, dissipation factor and quality factor are possible with external oscillator (range will be a function of applied frequency).

GENERAL

POWER SUPPLY: 115 or 230 volts $\pm 10\%$, 50–60 Hz, approx. 7 watts.

DIMENSIONS: Nominally $7\frac{3}{4}$ in. wide by 6 $\frac{1}{2}$ in. high by 11 in. deep.

WEIGHT: Net, 11 lbs. (5 kg). Shipping, 15 lbs. (6.8 kg).

PRICE: Model 4260A Universal Bridge, \$550.00.*

Manufactured by Yokagawa-Hewlett-Packard, Ltd., Japan, an international joint-venture company. Data subject to change without notice.

* Price in U. S. A. f.o.b. Palo Alto, California.

APPENDIX

AC BRIDGE LOCI

A generalized ac impedance bridge is shown in Fig. 1. The bridge is driven by a voltage E_i across the corners OQ . When the voltage across arm OP equals the voltage across arm OS , the output voltage E_o is zero. At this time, the bridge is balanced and

$$Z_1 Z_4 = Z_2 Z_3 \quad (1)$$

From this relationship, the value of any of the four impedances can be calculated if the other three are known. It is of interest to know how the bridge behaves as it converges towards a balance point.

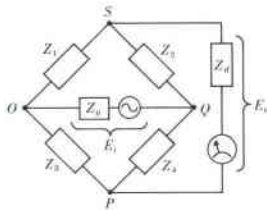

At balance ($E_o = 0$), $Z_1 Z_4 = Z_2 Z_3$

Figure 1

GENERAL CONSIDERATIONS

Two types of bridges, both using resistances in two of the arms, are shown in Fig. 2. The bridge of Fig. 2a is used when the unknown impedance Z_x has a reactance of the same sign as the reactance in the standard impedance Z_{st} . In the bridge of Fig. 2b, the reactances of Z_x and Z_{st} have opposite signs.

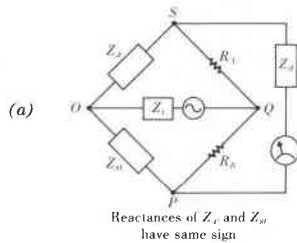

Reactances of Z_x and Z_{st} have same sign

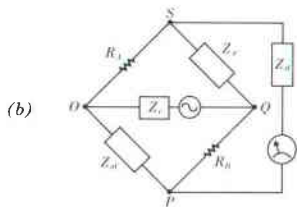

Reactances of Z_x and Z_{st} have opposite signs

Figure 2

The following is assumed:

- (1) The driver impedance Z_i is low com-

pared to the bridge impedance looking into the points O and Q ;

- (2) The detector impedance Z_d is high compared to the bridge output impedance as seen at the points S and P .
- (3) All impedances including the unknown are linear.

It is assumed that the bridge is balanced by the following procedure:

- (1) R_1 is set approximately to the absolute value of Z_x ;
- (2) R_2 and Z_{st} are adjusted alternately, each adjustment being made to bring the output voltage E_o to a value that is lower than that of the previous adjustment.

Following step (1), the voltage across arm OS has a particular vector relationship with the driving voltage OQ , as shown in Fig. 3. Step (2) then brings the head of vector OP in coincidence with the head of vector OS . We may consider S as a fixed point and then investigate the position of P as a function of Z_{st} and R_B .

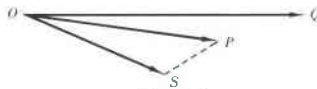

Figure 3

LOCI OF P

Consider the case when Z_{st} consists of a resistance R_p in parallel with a pure reactance X_p (Fig. 4). If the voltage across

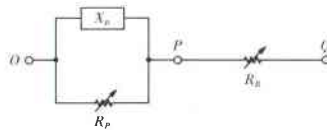

Figure 4

OQ is normalized to a unit vector lying on the X axis with its tail at the origin, the X - Y coordinates of P in the complex plane are determined by the vector relationship:

$$\frac{Z_{st}}{Z_{st} + R_B} = x + jy \quad (2)$$

Substituting

$$\frac{jX_p R_p}{R_p + jX_p}$$

for Z_{st} and separating imaginary terms from real terms, the X - Y coordinates may be derived:

$$x = \frac{R_p(R_p + R_B)}{(R_p + R_B)^2 + R_B^2 \left(\frac{R_p}{X_p}\right)^2} \quad (3)$$

$$y = \frac{R_p^2 R_B}{X_p} \frac{1}{(R_p + R_B)^2 + R_B^2 \left(\frac{R_p}{X_p}\right)^2} \quad (4)$$

In many bridges of practical design, the standard reactance X_p has a fixed value and only R_B and R_p are adjustable. Hence, we are concerned primarily with the behavior of P as R_B and R_p are adjusted alternately.

The locus of point P as R_B is adjusted while R_p remains fixed can be determined by eliminating R_B from equations (3)

and (4). Equations (3) and (4) can be combined thus:

$$\frac{y}{x} = \frac{R_p R_B}{X_p (R_p + R_B)} \quad (5)$$

$$R_B = \frac{R_p X_p}{R_p - \frac{y}{x} X_p} \quad (6)$$

Substituting equation (6) into equation (3) yields:

$$\left(x - \frac{1}{2}\right)^2 + \left(y + \frac{1}{2} \cdot \frac{X_p}{R_p}\right)^2 = \left(\frac{1}{2}\right)^2 + \left(\frac{1}{2} \cdot \frac{X_p}{R_p}\right)^2 \quad (7)$$

Equation (7) represents a family of circles, as shown in Fig. 5. The centers of

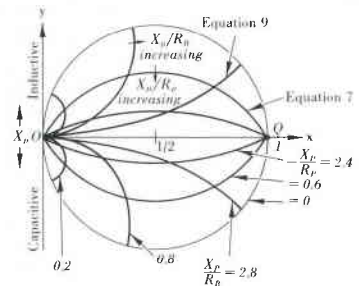

Figure 5

these circles lie on the vertical line that bisects the line OQ . The location of each circle center depends on the ratio X_p/R_p . Similarly, from equation (5)

$$R_p = \frac{y R_B X_p}{R_B - \frac{y}{x} X_p}$$

Substituting this into equation (3) yields:

$$x^2 + \left(y - \frac{1}{2} \cdot \frac{X_p}{R_B}\right)^2 = \left(\frac{1}{2} \cdot \frac{X_p}{R_B}\right)^2 \quad (9)$$

Equation (9) also represents a family of circles, as shown in Fig. 5. The centers of these circles lie on the Y axis and are determined by the ratio X_p/R_B .

A similar analysis for the case when Z_{st} consists of a resistance R_x in series with a reactance X_s also yields a family of circles for the loci of point P .

In a conventional bridge, R_B and R_p are adjusted alternately, each adjustment bringing the detector deflection to a new minimum. With R_p held constant, point P moves along a circular arc described by equation (7) as R_B is adjusted. With R_B held constant, point P moves along an arc described by equation (9) as R_p is adjusted.

If the detector is not sensitive to phase but is sensitive only to the absolute value of the vector difference between points P and S (see Fig. 3), a minimum is achieved when point P is moved along a circular arc until the line between P and the center of the arc moves onto point S . A typical convergence as R_B and R_p are alternately adjusted for minimums is shown in Fig. 3 on page 7.

— Hitoshi Noguchi

A PLUG-IN UNIT FOR EXTENDING COUNTER-TYPE FREQUENCY MEASUREMENTS TO 12.4 GHz

TWO BASIC TECHNIQUES have been used for several years to extend into the microwave region the accuracy of digital frequency measurements. Transfer oscillators, in conjunction with counters, can measure to 15 GHz. Heterodyne frequency converters, the other means for extending the range of counters, have until recently been limited to about 3 GHz.

Transfer oscillators zero beat the unknown input signal with harmonics of a low frequency oscillator. The frequency of the oscillator is measured by the counter, then some means is used to find which harmonic of the oscillator gave zero beat.

A frequency converter uses a quite different approach. It translates downward in frequency an unknown high-frequency signal by mixing it with a precisely known signal of slightly lower frequency. This heterodyne process yields a difference frequency within the basic range of the counter. Then the counter reading plus the known frequency of the mixing signal are added directly to give the unknown.

A frequency converter has some distinct advantages over transfer oscillators. It is much easier to use than manual transfer oscillators. But in particular it is capable of much higher resolution measurements than any transfer oscillator. This is because the plus or minus one count resolution limit of the counter is not multiplied by the harmonic number as in a transfer oscillator.

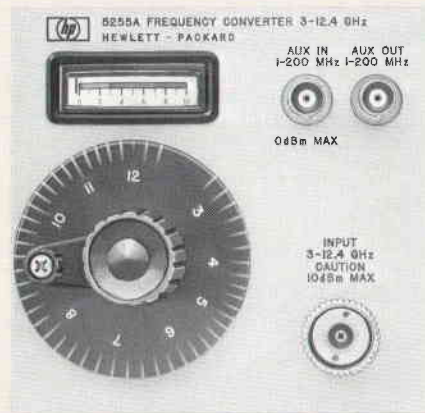

Fig. 1. The dial markings on the cavity tuning dial of the *hp* Model 5255A Frequency Converter Plug-in are transparent and give a red indication when the cavity is tuned to a harmonic of 200 MHz.

Recently the ease and accuracy of measurement with a heterodyne converter have been extended through 12.4 GHz (X band). A new converter plug-in, Fig. 1, has been designed for use with the *hp* Model 5245L and 5246L 50-mHz Electronic Counters to permit measurement of frequencies between 3 and 12.4 GHz, a range of over 4 to 1.

All ambiguity has been eliminated from the operation of the converter. There are no spurious responses within the frequency range of the converter or in adjacent bands. Furthermore the counter display is suppressed if insuffi-

cient signal is present for accurate measurement or if the converter is mistuned.

The new frequency converter requires a signal of only 100 mV into 50 ohms (-7 dBm), Fig. 2, and has an input SWR of less than 2 up to 12.4 GHz (Fig. 3).

A 200-MHz signal, multiplied up from the precision frequency standard of the counter, Fig. 4, and having the same accuracy, is used to drive a specially designed Hewlett-Packard Associates step-recovery diode. This diode generates a spectrum of 200-MHz harmonics, including every harmonic from 2.8 GHz through 12.4 GHz. As the converter is tuned through its frequency range, a resonant cavity selects each harmonic in sequence and allows it to pass into the broadband balanced mixer. A signal of unknown frequency, connected to the converter input, is also present in the mixer. A difference frequency signal is produced which, when it is in the passband of the video amplifier (1 MHz to 212 MHz) is counted and displayed. The counter, although rated to 53 MHz, is able to display the correct difference frequency throughout the entire amplifier range since the video signal is divided by four in a prescaler circuit and the counting time is extended by a factor of four in a gate time extender circuit. Both circuits are in the converter plug-in, and both functions occur automatically when the counter is operated in its 'Plug-in' mode.

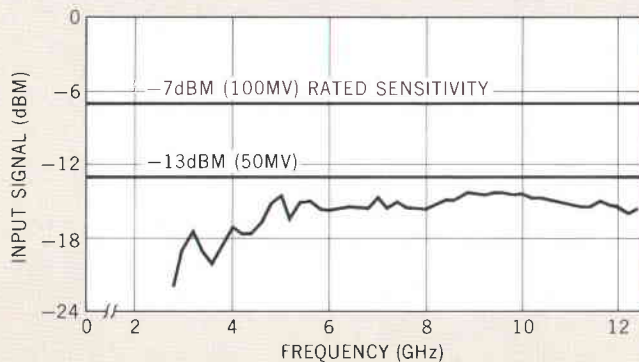

Fig. 2. This sensitivity plot shows the input signal level that is required for counting, that is, to put the panel meter into the green region.

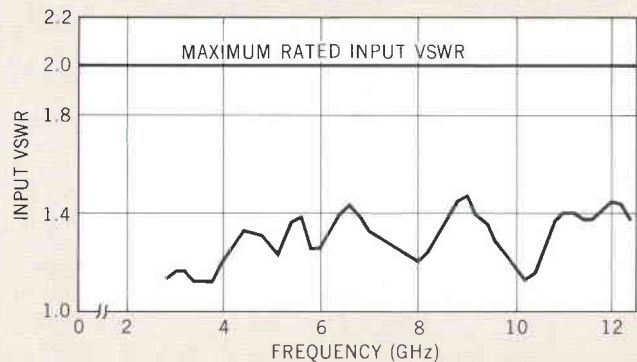

Fig. 3. Input VSWR of the converter is unusually low, typically well below 2.0.

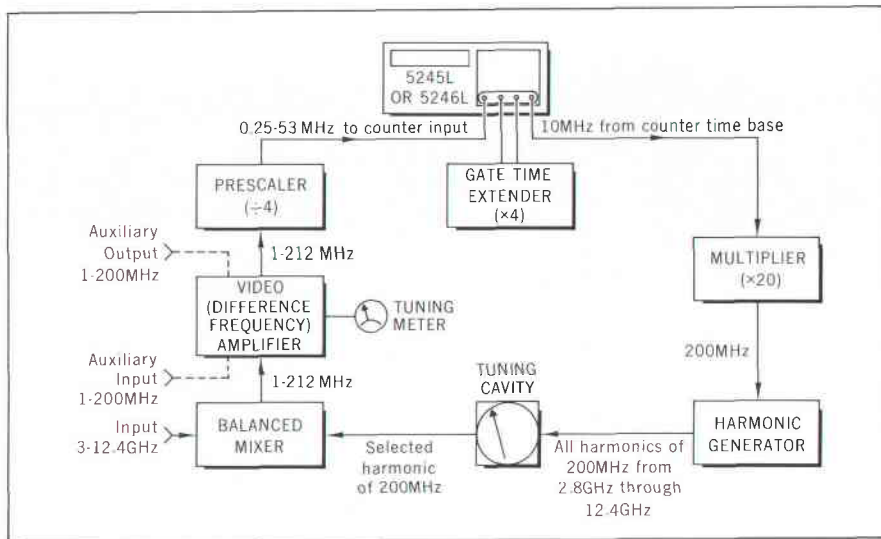

Fig. 4. In the -hp- Model 5255A Frequency Converter Plug-in, the difference frequency between the input and the harmonic is divided by four to put it in the range of the counter. Gate time is then extended four times so that the counter reads frequency directly.

OPERATION

To measure an unknown frequency, the converter is tuned starting at the low frequency end of the dial until the front panel meter indicates the presence of a video (difference frequency)

signal. Then the reading on the counter is added to the frequency reading on the converter dial, that of the 200-MHz harmonic selected. Since the mixing signal contains zeroes in most of its significant decimal places, addition is easy. By tuning from the low end, the harmonic selected is always below the unknown in frequency so that the two frequencies are merely added. If the converter is tuned from the high end of the dial, the first 200-MHz harmonic encountered which gives a video difference frequency will be above the unknown, and thus the readings will have to be subtracted. This reading could be used for frequency confirmation if desired.

It is important to realize that the 200-MHz harmonics selected by tuning the converter, because they are integral multiples of the counter frequency standard, are precisely known. Furthermore, the difference frequency is displayed with the up to eight digit resolution available on the counter. Thus frequency measurements using the converter, although simple, yield unusually high resolution. For example, with the counter time base set at 1 second (which gives a four second counting time because of the gate time extension in the plug-in), the input microwave

frequency is measured to 1 Hz.

DOWN-CONVERTER USAGE

Although the basic function of the converter is to measure microwave signal frequencies, the converter has other useful modes of operation. On the front panel are two BNC connectors, one an extra input to the video amplifier, the other an additional video amplifier output. The extra input allows direct use of the amplifier and prescaler sections of the converter for sensitive 1- to 200-MHz counting. Using this 50-ohm input, a signal of only 5 millivolts between 1- and 200-MHz can be counted and displayed directly. (This might be compared with a typical counter which has about 100-mV sensitivity.)

The extra front panel output, also 50 ohms, supplies the difference frequency being displayed by the counter, that is, the difference between converter input frequency and the adjacent 200-MHz harmonic reference frequency. The difference frequency must, of course, be within the 1- to 212-MHz passband of the video amplifier. Availability of this signal means that the converter can function as a general-purpose down-converter for translating microwave signals from 3- to 12.4-GHz down into the 1- to 200-MHz range. Such a signal could be viewed on an oscilloscope, or be used to measure frequency deviation. This output can also be used to lock a microwave oscillator to a low-frequency reference signal. Adding a detector at this output enables the converter to be used as a receiver.

CAVITY DESIGN

Considerable effort was made in the design of this instrument to avoid any possibility of measurement ambiguity and to assure simplicity of operation. The cavity, which tunes from 2.8 GHz through 12.6 GHz with linear motion, has no spurious resonances either within the frequency range of the instrument or within adjacent bands. Such responses could cause ambiguity, or at least inconvenience during measurement. The closest calculated spurious mode of the cavity is above 18 GHz, although there is no response because of the insufficient harmonic power generation near that frequency.



JOHN N. DUKES

John Dukes joined the Frequency and Time Division of Hewlett-Packard in 1962. Previously, he had worked in microwave receiver development. Before beginning on the 5255A he participated in the design of the 5100A and 5105A Frequency Synthesizers. He holds the degree of B.A. from Oberlin College, the BSEE from the University of North Dakota, the MSEE from the University of California at Berkeley, and the degree of Electrical Engineer from Stanford, the last earned while on the -hp- Honors Cooperative Program.

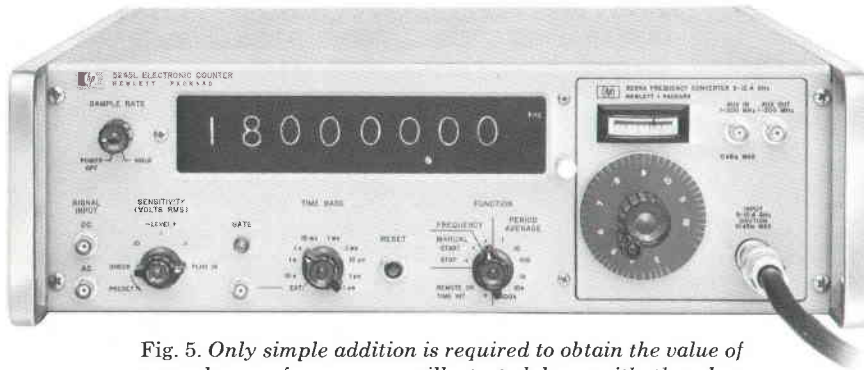

Fig. 5. Only simple addition is required to obtain the value of an unknown frequency as illustrated here with the *-hp-* Model 5255A Frequency Converter in use with the *-hp-* Model 5245L Electronic Counter. The converter cavity is tuned to the 200 MHz harmonic that appears at the 9 GHz dial setting. The counter shows the difference frequency between that harmonic and the input frequency, or 180 MHz. Thus the frequency being measured is 9.180 GHz.

The mechanical drive that tunes the cavity positions a tuning probe to within a few millionths of an inch, yet there is no perceptible backlash from tuning knob to cavity.

The linear dial that reads out the frequency selected by the cavity is achieved without cams. The dial point is illuminated only when a specific harmonic is tuned, thus indicating graphically that although the dial rotates with continuous motion as the tuning knob is turned, only discrete frequencies are selected from the cavity.

ELIMINATING AMBIGUITY

While ease and clarity of operation are important in a frequency measuring instrument, accuracy and precision are fundamental. Tuning responses at submultiples of the input frequency caused by harmonic mixing are a traditional problem in improperly designed converters, and will give indication of a signal at approximately $f/2$ or $f/3$, etc., for an input of frequency f . This serious ambiguity is avoided in this converter (as in previous *-hp-* frequency converters) by a carefully designed broadband balanced mixer plus the controlled and uniform signal level from the cavity into the mixer across the entire frequency range.

Insufficiently sharp cutoff at the high frequency end of the video amplifier bandpass — also often present in poorly designed converters — can cause erroneous frequency displays or misleading

operation. In this case, a strong input signal may cause the tuning meter to indicate sufficient signal level for proper counting even though the frequency of the video signal is beyond the range of the basic counter. In the new converter this possibility is eliminated by an extremely sharp cutoff at a video frequency of 212 MHz, which corresponds to the 53 MHz high frequency input rating of the basic counter. (Generally cutoff is achieved with passive filters that attenuate frequencies outside the amplifier passband. This converter uses a discriminator-type of circuit that senses frequency, and, when the frequency is beyond 212 MHz inhibits both counting and amplitude response of the tuning meter.)

A high signal-to-noise ratio has been maintained throughout the converter. Thus when the tuning meter indicates that sufficient signal strength is present for counting, that is, when the meter moves from the red region at the bottom of the scale into the green region, counting will be steady and accurate. Turning the front panel control peaks the tuning meter, but even if the meter is not peaked the counting remains stable and accurate. When the meter is in the red region, counting is suppressed. An automatic counter reset pulse generated as threshold is passed in either direction means that as the counter is tuned, the counter display changes from all zeroes to a correct full count, and upon detuning resets immediately to zeroes.

FM INPUT SIGNALS

Although the converter is designed for measuring CW signals, its operation is unaffected by large amounts — many megahertz — of FM on the input signal. The only constraint is that after frequency translation in the mixer, the peak deviations on the input signal must remain within the passband of the video amplifier.

ACKNOWLEDGMENTS

I mention with pleasure and gratitude the eager competence of the group that designed this instrument. David D. Smith, Lawrence A. Lim and Kenneth J. Wayne divided and conquered the highly formidable problems of mechanical engineering — with a major assist by machinist Jacob Barton. With initial cavity design by Ronald W. Potter, the bulk of the electrical design was handled by Richard D. Pering, David C. Chu, Lee S. Ting, and the undersigned. Coming into the project relatively late, but with much appreciated assistance was Hans Trosch. The dial design was by Allen E. Inhelder.

— John N. Dukas

SPECIFICATIONS*

—hp—

MODEL 5255A FREQUENCY CONVERTER

RANGE: As a converter for *-hp-* Models 5245L/5246L Counters, 3 to 12.4 GHz using mixing frequencies of 2.8 to 12.4 GHz in 200 MHz steps. As a prescaler, 1 MHz to 200 MHz.

ACCURACY: Retains counter accuracy.

INPUT SENSITIVITY: 100 mV rms (−7 dBm) as a converter, 5 mV rms as a prescaler.

INPUT IMPEDANCE: 50 ohms nominal.

MAX. INPUT: +10 dBm; 0 dBm on AUX IN.

LEVEL INDICATOR: Meter aids frequency selection; indicates usable signal level.

AUXILIARY OUTPUT: 1 MHz to 200 MHz difference signal from video amplifier.

REGISTRATION: Counter display in MHz is added to converter dial reading.

INSTALLATION: Plugs into front panel plug-in compartment of *-hp-* Models 5245L and 5246L Electronic Counters.

INPUT VSWR: <2.0

INPUT CONNECTOR: Precision Type N female. GPC-7 connector optional.

WEIGHT: Net, 8¼ lbs. (3.8 kg). Shipping, 12 lbs. (5.5 kg).

PRICE: \$1,650.00

*When used with the *-hp-* Model 5245L 50-MHz Electronic Counter, serial prefixed 402 and above, and the *-hp-* Model 5246L Electronic Counter.

Prices f.o.b. factory

Data subject to change without notice

NEW FCC RULES FOR FM STEREO FREQUENCY CONTROL

NEW FCC REGULATIONS to go into effect November 1, 1966 will require FM stereo broadcast stations to maintain their 19 kHz pilot subcarrier to within 2 Hz. Those stations carrying an additional SCA (Subsidiary Communications Authorization) subcarrier will be required to maintain its frequency to within 500 Hz. SCA uses a vacant part of the FM channel to provide monaural music, facsimile and auxiliary services. More than one SCA service may be provided. Measurements must be made as often as necessary to insure stability, or at least once each day.

To date, the FCC has not required proof of stereo performance by an FM stereophonic station. This recent amendment to FCC Rules and Regulations, Vol. III, Part 73, Radio Broadcast Services, insures that the transmitted signal, when received on a properly adjusted receiver, will have channel separation to produce a stereo effect.

Stability of the 19-kHz pilot subcarrier is important in the ability of a receiver to separate right and left channel information. How this pilot subcarrier is used is shown in Fig. 1. The left and right channel (L + R) information is transmitted with a 15-kHz bandwidth and is the monaural signal.

To separate the stereo channels, it is necessary to send additional information in the form of a signal which is the difference between the channels, or (L-R). This is transmitted as amplitude modulation on a 38-kHz subcarrier superimposed on the main FM carrier, Fig. 1. Although unintelligible by itself, the (L-R) signal is used in the process of reproducing the program material as the two original channels. SCA, if used in addition to stereo, may be transmitted at subcarrier frequencies of from 59 to 75 kHz.

The 38-kHz subcarrier is suppressed at the transmitter for better utilization

of the modulation capabilities of the FM transmitter. Most practical detection methods involve reinserting this carrier at the receiver to retrieve the (L-R) information. When doubled in the receiver, the 19-kHz pilot subcarrier can be used as the reinserted 38-kHz subcarrier.

High-Q tuned circuits are necessary at the receiver to get the 19 kHz out of the received FM signal. If these circuits are slightly mistuned, or if the 19-kHz signal is off frequency, a loss of stereo separation or distortion results due to the change in phase caused by the signal being at a different part of the filter characteristic.

Existing FCC type-approved monitors do not have circuitry to measure the accuracy of the 19-kHz subcarrier frequency. But electronic counters using a quartz crystal time base meet the FCC accuracy requirements and offer a simple, yet flexible means of making these measurements. Several *-hp-* electronic counters are suitable for making subcarrier frequency measurements. Counters with extended frequency ranges are also useful for making carrier frequency checks.

The accompanying table lists those *-hp-* counters suitable for frequency measurements of this type. All have a

resolution of essentially ± 1 Hz at the 1 second time base setting when measuring 19 kHz. Those counters with a 10 second time base available will provide a resolution of ± 0.1 Hz, which is a desirable capability in view of the tight FCC requirement.

Crystal oscillator stability given in the table is the aging rate of the crystal oscillator and is both a measure of overall oscillator stability and a guide to the allowable time between successive calibrations to maintain accuracy.

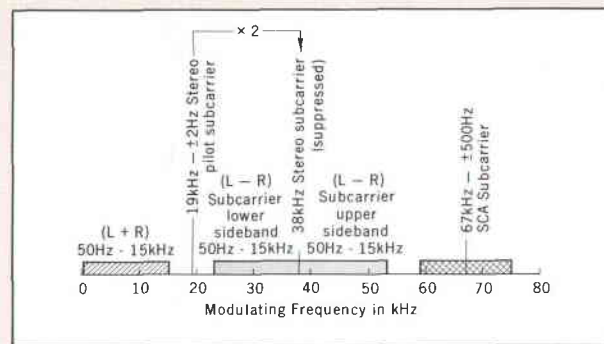

Fig. 1. Graphical representation showing how information is transmitted on a typical FM channel for a stereophonic station carrying one channel of SCA. When only one SCA service is provided, a 67-kHz subcarrier is used.

ELECTRONIC COUNTERS FOR FM STEREO MEASUREMENTS

<i>-hp-</i> Model	Maximum Frequency	Crystal Oscillator Frequency Stability
3734A ¹	5.0 MHz	< ± 2 parts in 10^6 per week
3735A ²	12.5 MHz	< ± 2 parts in 10^7 per month
5212A/5512A ²	300 kHz	< ± 2 parts in 10^6 per week
5232A/5532A ²	1.2 MHz	< ± 2 parts in 10^7 per month
5245L ²	50 MHz [*]	< ± 3 parts in 10^9 per day
5246L	50 MHz [*]	< ± 2 parts in 10^7 per month
524C/D ²	10 MHz	< ± 5 parts in 10^8 per week
523C/D ²	1.2 MHz	< ± 2 parts in 10^6 per week
522B ²	120 kHz	< ± 10 parts in 10^6 per week

¹10-second time base available as option.

²Has 10-second time base.

^{*}Plug-in units available to extend frequency range to 12.4 GHz for other station measurements and for microwave link frequency measurements.

A FREQUENCY COMB GENERATOR WITH A RANGE FROM 1 MHz TO BEYOND 5 GHz

CRYSTAL CALIBRATORS, long used to generate RF marker frequencies for calibrating receiver dials, frequency meters, wavemeters, and other frequency sensitive devices, are limited in range because of the small amplitude of the higher harmonic frequencies. Recently, it has become possible to greatly increase the frequency range of calibrators by taking advantage of the characteristics of step recovery diodes. Step recovery diodes increase the harmonic content substantially by introducing sharp transients into the basic waveform.¹

Step recovery diodes enable the frequency range of a new calibrator to extend well beyond 5 GHz. The calibrator has three internal crystal-controlled oscillators at frequencies of 1, 10, and 100 MHz and a step recovery diode that shapes the oscillator outputs into extremely narrow pulses (see block diagram, Fig. 7). The narrow pulse width (less than 100 picoseconds) provides marker frequencies of useful amplitude from 1 MHz to beyond 5 GHz. On a plot of signal amplitude vs. frequency, such as that displayed by a spectrum analyzer, the instrument output resembles a comb, with frequency component spacings of 1, 10, or 100 MHz depending on the oscillator selected (Fig. 1). Hence, the instrument

¹ Robert D. Hall and Stewart M. Krakauer, 'Microwave Harmonic Generation and Nanosecond Pulse Generation with the Step-Recovery Diode,' *'Hewlett-Packard Journal,'* Vol. 16, No. 4, Dec., 1964.

is called a Frequency Comb Generator.

The new Frequency Comb Generator was developed primarily as a convenient and accurate frequency calibration accessory for the *-hp-* Model 851A/8551A Broadband Spectrum Analyzer.² It can be used as well for the calibration of other instruments with wide tuning ranges, such as receivers, signal generators, sweep oscillators,

² Harley L. Halverson, 'A New Microwave Spectrum Analyzer,' *'Hewlett-Packard Journal,'* Vol. 15, No. 12, Aug., 1964.

and wavemeters. Frequency accuracy of each oscillator, and thus of each harmonic component, is $\pm 0.01\%$.

The new instrument also functions as a source of impulses for testing system response in the time domain. Furthermore, it can be used for broadband frequency response measurements by impulse testing, as described later in this article.

The Frequency Comb Generator can also be driven by an external sine wave in the range from 1 to 200 MHz (the sine wave should have an amplitude of 1 to 3 volts rms). The resultant comb then has the frequency spacing, accuracy, and stability of the external signal. This function enables a 1- or 5-MHz frequency standard to be extended up to hundreds or thousands of MHz by harmonic multiplication. In addition, internally-generated 1-MHz components can be added to the 10-MHz comb, providing frequency components spaced at 1 MHz with every tenth component at a higher ampli-

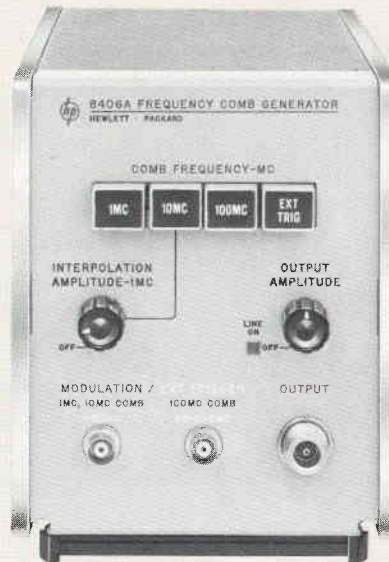

Fig. 2. Model 8406A Frequency Comb Generator supplies internally-generated frequency components spaced at 1, 10, or 100 MHz for calibration of broad tuning-range devices up to 5 GHz. Other frequencies within range of 1 to 200 MHz may be used to drive Comb Generator.

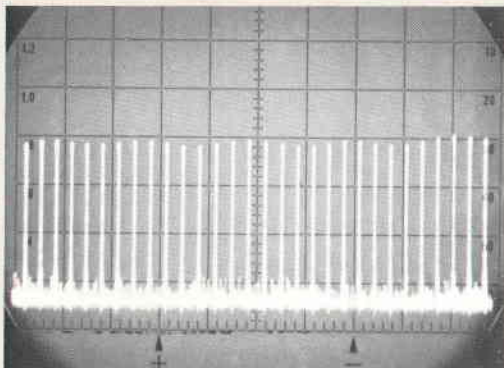

Fig. 1. Portion of spectrum generated by new Frequency Comb Generator as displayed on Spectrum Analyzer. Portion of comb shown here is 300 MHz band of 10 MHz components (display is set for 30 MHz/cm spectrum width). Frequency components shown here, with spectrum analyzer set for logarithmic response, have amplitudes that differ by less than 2 dB.

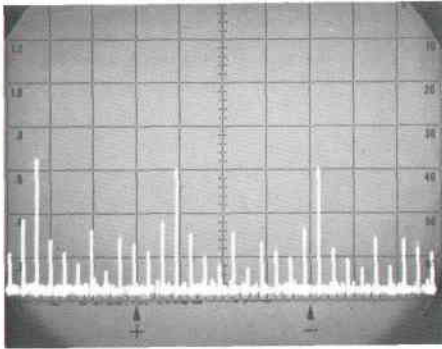

Fig. 3. 10-MHz frequency comb with added 1-MHz components. Higher amplitude of 10-MHz components provides decade scale marks for easier identification of 1-MHz increments.

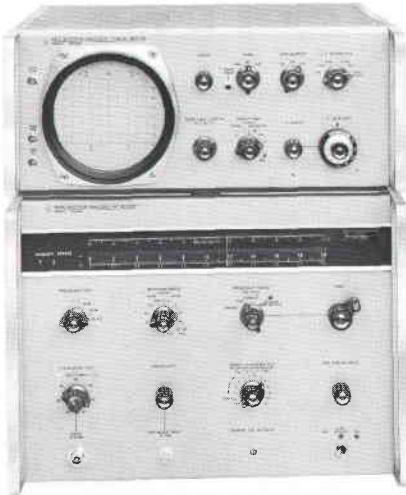

Fig. 4. Hewlett-Packard Wideband Spectrum Analyzer, for which Comb Generator was designed, displays up to 2000 MHz of radio spectrum at a time. Wide tuning range (10 MHz to 40 GHz) and wide display amplitude range (>60 dB) of Spectrum Analyzer enable evaluation of signals widely separated both in amplitude and frequency. Analyzer was designed for straightforward operation; reduction of spurious and residual responses assures minimum confusion. Controls are calibrated so that frequency and relative amplitude can be read directly. Comb Generator provides markers for higher precision in frequency determination.

tude (Fig. 3). An external signal can also be used to phase-modulate the output of any of the internal oscillators to provide interpolation side-bands on the comb components (see Fig. 12).

THEORY OF OPERATION

In the time domain, the output of the Frequency Comb Generator is a train of narrow, positive pulses at a repetition rate that is the frequency of the selected internal crystal-controlled oscillator or external source (Fig. 5). On a sampling oscilloscope that has 90-ps risetime, these pulses are displayed as having a width of 100 ps and an amplitude of $\frac{1}{2}$ volt. Calculations based on the amplitude and number of frequency components as displayed on a spectrum analyzer indicate that the pulses actually are less than 70 ps wide and have an amplitude of about $\frac{3}{4}$ volt.

The spectrum, or frequency domain representation, of a pulse train consists of a dc component, a fundamental frequency component (the repetition rate) and higher frequency components occurring at harmonics of the fundamental, as in Fig. 6.* Since the output waveform approximates an impulse, each harmonic component, including the fundamental, has approximately the same amplitude. However, the pulses do have a finite width, T_w , so that the envelope of the spectrum falls off as the frequency of the harmonic components approaches $1/T_w$ and may actually go through a null at frequency $1/T_w$. Because the pulse width of the Frequency Comb Generator has been made less than 100 picoseconds, the null occurs beyond 10 GHz and useful spectrum content thus extends well beyond 5 GHz.

ACCURATE DETERMINATION OF A SIGNAL FREQUENCY

The Frequency Comb Generator can be used to improve the accuracy of frequency determination with a broadband Spectrum Analyzer, as described on page 17. The accuracy of such a measurement is the possible absolute frequency error of the comb ($\pm 0.01\%$) plus or minus the possible error in the analyzer frequency display calibration

* Actually, no dc appears in the output of the Frequency Comb Generator because of a shorted-stub differentiator in the output circuit.

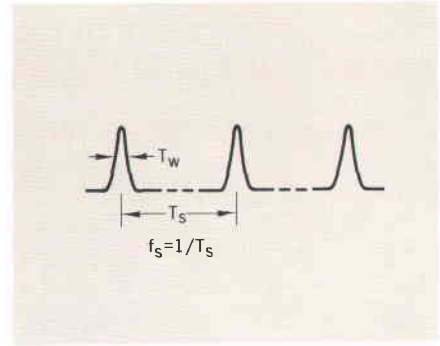

Fig. 5. Time Domain representation of output pulse train of Frequency Comb Generator. Pulse width is designated T_w and pulse rate period is T_s . Actual pulses have ratio of T_w/T_s that ranges from less than 0.0001 to 0.01.

(sweep linearity) that was used in measuring the last increment (5% for the Model 851A/8551A Spectrum Analyzer). In the case described on page 17, the maximum possible error is $(\pm .0001)$ (1850 MHz) $\pm (.05)$ (.35 MHz), which equals 0.2025 MHz. This is an accuracy of 0.011%. The accuracy in this case is determined primarily by the 1-MHz crystal oscillator in the Frequency Comb Generator while the linearity of the Spectrum Analyzer sweep is only of secondary importance.

FREQUENCY CALIBRATION OF INSTRUMENTS

The new instrument can also be used as a source of input signals to check the

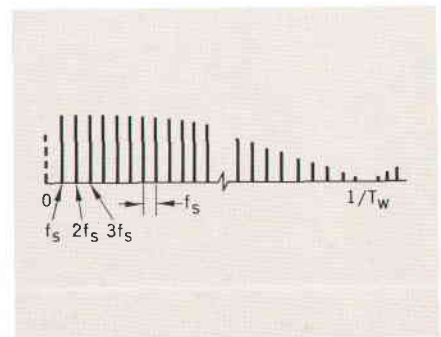
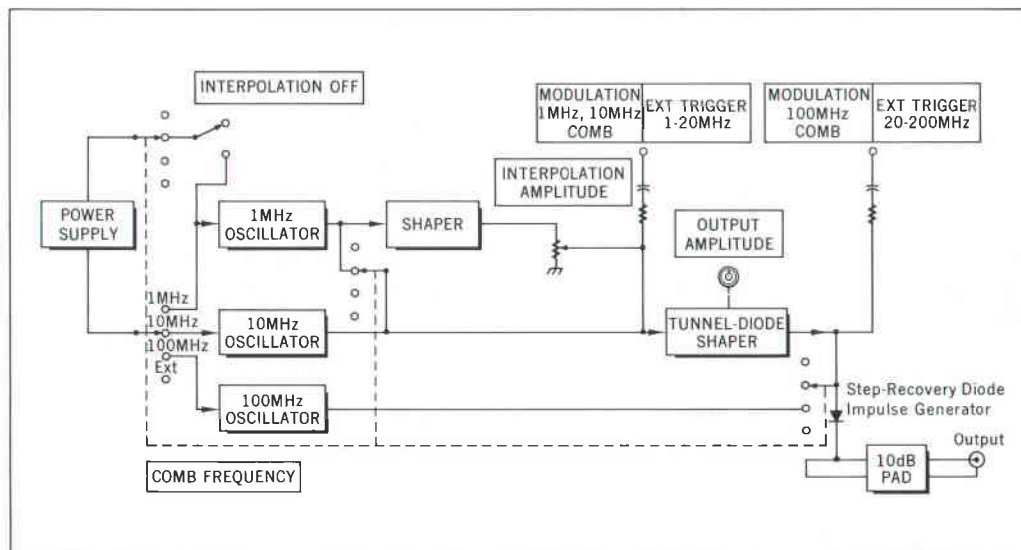

Fig. 6. Frequency domain representation of pulse train shown in Fig. 5. With ideal pulses, frequency components would be of near identical amplitude out to $1/\pi T_w$ and may go through a null at a frequency of $1/T_w$.

Fig. 7. Block diagram of Frequency Comb Generator. Step recovery diode working into shorted stub line differentiator generates output impulse. One of three crystal oscillators energized by front panel push buttons drives step recovery diode. Tunnel-diode shaper speeds up rise times of lower frequency drive signals sufficiently to drive step recovery diode. 10-dB pad makes output impedance a nominal 50 ohms because of low impedance of shorted stub.



ACCURATE DETERMINATION OF A SIGNAL FREQUENCY ON A SPECTRUM ANALYZER

The series of photographs shown here illustrate how the Frequency Comb Generator described in the accompanying article can be used to improve the accuracy of frequency determination with a broadband Spectrum Analyzer. Fig. (a) shows the analyzer display of a signal combined with the 100 MHz comb. The large spike at the left is caused by local oscillator feedthrough in the spectrum analyzer and provides a convenient zero frequency reference. Counting the comb frequency components from the left shows that the signal lies between 1800 and 1900 MHz. Now the analyzer is tuned to place the 1800 MHz marker at zero cm and the analyzer spectrum width is set to 10 MHz/cm (Fig. b). Switching to the 10 MHz comb and again counting harmonics shows that the signal is between 1840 and 1850 MHz (Fig. c). The spectrum width is next switched to 1 MHz/cm (d) and the 1-MHz components are added to the 10-MHz comb, as in Fig. (e), which shows that the signal is between 1847 and 1848 MHz. With the horizontal scale expanded to 100 kHz/cm, the signal frequency is read as 1847.35 MHz (Fig. f).

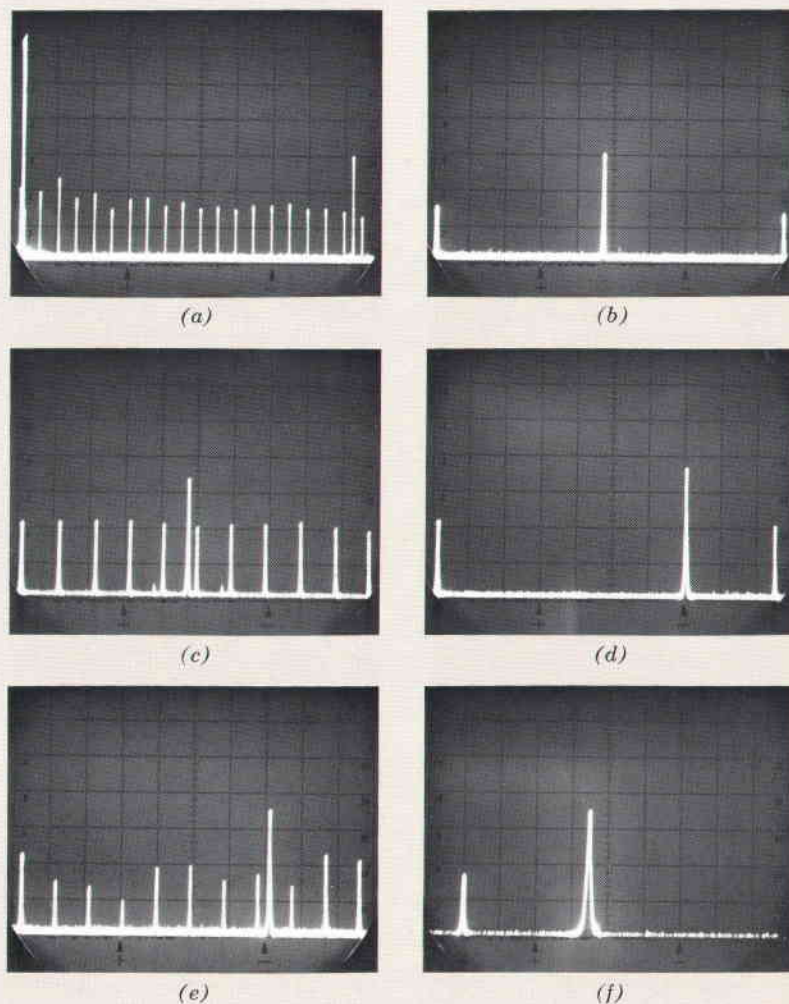
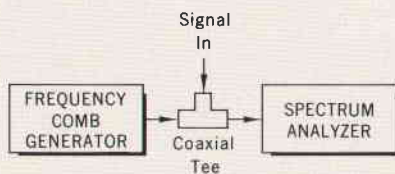

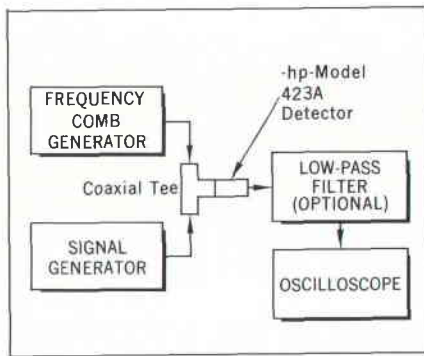

Fig. 8. When Frequency Comb Generator is used for calibration of signal generators, crystal detector acts as mixer to provide sum and difference products between signal generator output frequency and comb frequencies. Oscilloscope serves as zero-beat indicator to show when signal generator output and comb component are at same frequency.

accuracy of a spectrum analyzer tuning dial by setting the analyzer tuning dial cursor to the frequency of a comb component, and then observing the displacement of that component with respect to the center of the CRT display. Obviously, sweep calibration accuracy and linearity can also be checked by measuring the separation between the displayed comb components.

Tuning dials on high-frequency receivers are calibrated by tuning for a zero beat while the Frequency Comb Generator output is applied as the input signal. The harmonic components of the comb are the cardinal points at which the dial can be calibrated. Should an AM receiver not have a BFO, the AVC voltage may be used as a tuning indicator or, if the receiver is very sensitive, reception of a comb com-

ponent is indicated by quieting. The same would be true of an FM receiver.

Absorption wavemeters are readily calibrated with the Frequency Comb Generator and a spectrum analyzer. The comb generator output is fed through the wavemeter to the spectrum analyzer and, as the wavemeter is tuned over its range, dips occur in the observed comb components. Calibration is accomplished by comparing the wavemeter dial reading at the maximum dip of a particular comb component with the frequency of that component.

Signal generators are calibrated with the set-up diagrammed in Fig. 8. The detector shown in the diagram functions as a mixer to produce the sum and difference frequencies of the signal generator and Frequency Comb Generator outputs. The higher mixing products are removed by the low-pass filter. When the signal generator is tuned to exact coincidence between its output frequency and a comb component, the oscilloscope display shows a zero beat. This technique can also be used statically to calibrate a sweep oscillator or dynamically to place frequency marker pips on a swept-frequency display.

The same technique can be used to calibrate a wavemeter in case a spectrum analyzer is not available. The wavemeter is inserted in series between the Frequency Comb Generator and the detector and the cardinal tuning points are located by noting a dip in the detected output.

FREQUENCY RESPONSE MEASUREMENTS

The frequency response of linear systems is quickly determined by apply-

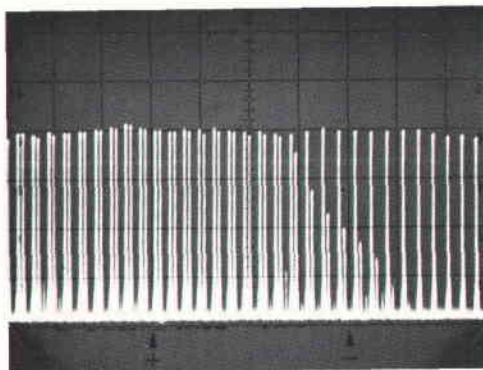

Fig. 9. Frequency response measurement of -hp- Model 360A 700-MHz low-pass filter using Frequency Comb Generator output as stimulus and spectrum analyzer to display results. Input and output combs are shown, displaced slightly with respect to each other for clarity. Comb which extends evenly towards right of display is input comb. Output of filter is comb that drops off in amplitude to right of center. Center screen is 700 MHz, spectrum width is 30 MHz/cm, and vertical calibration is 10 dB/cm, showing filter cutoff slope of approximately 42 dB/100 MHz.

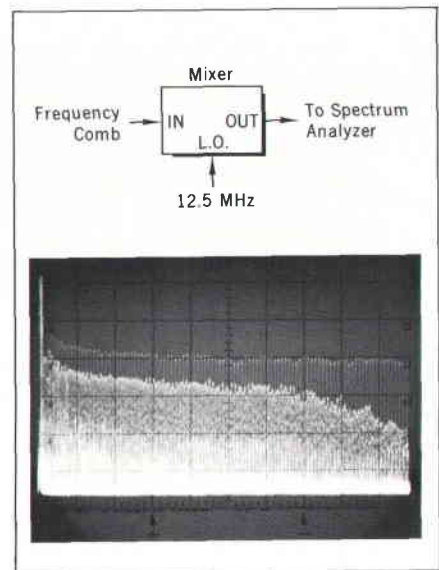



Fig. 10. Broadband balanced mixer conversion loss as determined by Frequency Comb Generator and spectrum analyzer in set-up shown in diagram. Upper comb shows 10-MHz frequency comb as applied to mixer. Lower comb, which is output of mixer, has comb components spaced at 5 MHz resulting from 12.5 MHz sidebands on each side of input comb components. Center of display is 500 MHz, spectrum width is 100 MHz/cm, and vertical calibration is 10 dB/cm. Conversion loss at any frequency is difference between comb amplitudes at that frequency.

ing the frequency comb to the input of the system or device and observing the resultant output spectrum on a spectrum analyzer. The ratio of the output comb to the input comb is the transfer function of the device in the frequency domain. With an ideally flat input comb, the envelope of the comb displayed on the spectrum analyzer is the frequency response of the device being tested.

Since the envelope of the comb generator output has some variations, this measurement is best made by an in-

HEWLETT-PACKARD JOURNAL

TECHNICAL INFORMATION FROM THE LABORATORIES OF THE HEWLETT-PACKARD COMPANY

VOL. 18, NO. 1  SEPT. 1966

PUBLISHED AT THE CORPORATE OFFICES
1501 PAGE MILL ROAD, PALO ALTO, CALIFORNIA 94304
Staff: F. J. Burkhard, Editor; R. P. Dojan,
L. D. Shergalis, R. A. Erickson, A.D.

DESIGN LEADERS



RODERICK CARLSON

Rod Carlson joined -hp- in 1958 as a development engineer, initially working on the 160A Militarized Oscilloscope and then as project leader for the 185A Sampling Oscilloscope and related equipment, such as the 213A Pulse Generator. Rod subsequently became manager of sampling oscilloscope development. He transferred to the -hp- Microwave Division in 1964 as project leader on the 8405A Vector Voltmeter and is presently manager of the Microwave Lab signal analysis section.

Prior to joining -hp-, Rod spent five years as an instrumentation engineer dealing with aircraft stability and control. He holds a BS degree from Cornell University and is a member of IEEE, Tau Beta Pi, Eta Kappa Nu, and Phi Kappa Phi.



HARLEY HALVERSON

Harley Halverson joined -hp- in 1957 while completing an M.S. degree at Stanford University. Prior to Stanford, Harley had been in the Air Force which he had joined on graduation from South Dakota State College.

At -hp-, Harley worked on the 355-series VHF Attenuators and the 606A HF Signal Generator. He then became project leader on the 8551A Wideband Spectrum Analyzer RF Unit and has continued in spectrum analyzer development since completion of that project.

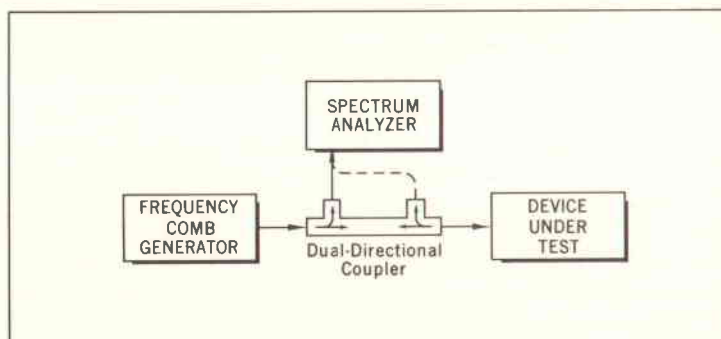

Fig. 11. Set-up for measurement of reflection coefficient with broadband Comb Generator/Spectrum Analyzer technique. Spectrum Analyzer initially is connected to forward auxiliary arm of coupler to monitor frequency comb applied to device under test. Spectrum Analyzer is then connected to reverse auxiliary arm to monitor reflected comb. Comparison of forward to reverse combs determines reflection coefficient.

servation method. The top of the comb, with the comb generator output applied directly to the spectrum analyzer and with the analyzer set for a logarithmic vertical display, is traced on the CRT face with a grease pencil. The device to be measured is then inserted between the comb generator and the spectrum analyzer and the comb displayed is compared with the pencil mark. The difference between combs represents the transfer function of the device in dB vs. frequency. This procedure may also be performed photographically by making a before-and-after double exposure, as shown in Fig. 9.

The frequency comb technique is a quick, moderately accurate, method of measuring frequency response and it has the added advantage that the frequency points are known very accurately. Fig. 9 shows the result of performing this measurement on a 700-MHz low-pass filter. Fig. 10 shows the

measurement of the conversion loss of a mixer vs. frequency using the method.

This technique can also be used to measure reflection coefficient. To do this, a dual directional coupler covering the frequency range of interest is inserted in the set-up, as shown in Fig. 11. The spectrum analyzer, set for a logarithmic display, is first connected to the incident wave terminal of the coupler and then to the reflected wave terminal. The difference between the two responses is the return loss directly in dB from which the reflection coefficient is easily calculated.

To assure validity of the comb method for measuring frequency response, the system under test must be capable of operating linearly with a ¼ volt pulse input if its input bandwidth is greater than 5 GHz. If an input filter can be used, or if the input bandwidth is less than 5 GHz, the necessary range of linear operation can be calculated

Fig. 12. Phase modulation of 100 MHz comb by 20 MHz sine wave results in sidebands astride each "tooth" of frequency comb. Shown here are 1000 MHz and 1100 MHz comb components (large amplitude responses) with 980, 1020, 1080, and 1120 MHz sidebands.

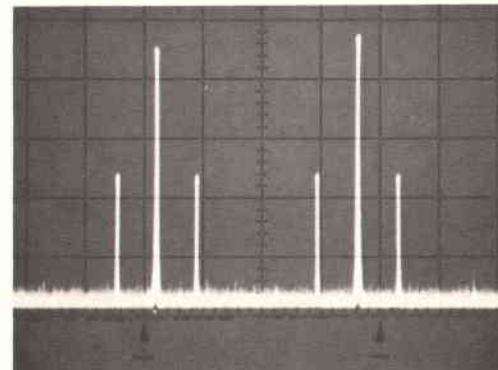

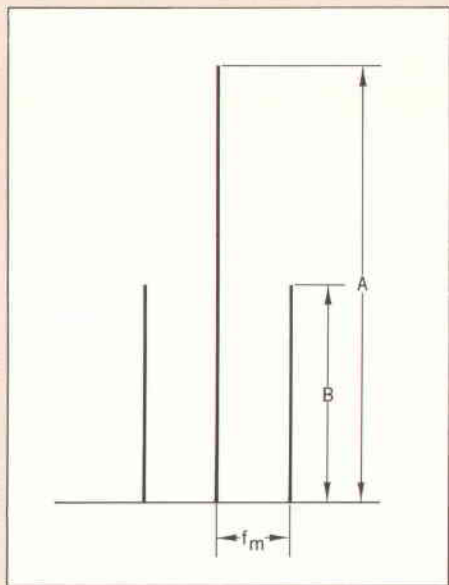

Fig. 13. Interpretation of spectrum display shown in Fig. 12. For modulation indices of less than 0.2, modulation index ($\Delta\theta$) equals ratio of twice one sideband amplitude to carrier amplitude ($\Delta\theta = 2B/A$). Frequency deviation (ΔF) is \pm product of modulating frequency (f_m) and modulation index ($\Delta F = \pm f_m \Delta\theta$).

from the knowledge that the Frequency Comb Generator output is 150 $\mu\text{V}/\text{MHz}$.

PHASE MODULATION CAPABILITY

Each of the internal combs can be phase modulated over a wide modulation frequency range by applying a low level signal (1–100 mV) to the appropriate external trigger input while the desired comb 'Frequency' button is depressed. Low-index phase modulation produces sidebands astride each tooth of the comb and spaced from the main comb by the modulation frequency.

As an example, Fig. 12 shows the 1000-MHz and 1100-MHz components, with their 20-MHz sidebands, resulting from modulation of the 100-MHz comb with a 20-MHz signal. The instrument is designed to enable the 1-MHz oscillator to phase modulate the 10-MHz comb, generating lower level 1-MHz components in the 10-MHz spectrum (Fig. 3).

This technique can be used for interpolation purposes when determining the frequency of a signal appearing on the spectrum analyzer. The modulation frequency provided by an exter-

nal source is varied until the sideband coincides with the unknown signal. Then the unknown frequency is the frequency of the main comb harmonic component \pm the modulation frequency, depending on whether an upper or lower sideband was made to coincide.

The amplitude required of a modulating signal for a given modulation index depends on the comb being modulated, the harmonic component, and the modulation frequency. The modulation frequency may be from kilohertz to tens of megahertz, permitting the generation of FM or phase modulation signals of low modulation index but at very high modulation frequencies.

The modulation index can be measured by observing the output signal on the spectrum analyzer (see Fig. 13). The modulation index of Fig. 12 is 0.2 which means the frequency deviation is ± 4 MHz. The Comb Frequency Generator has been used in this manner in our laboratory to measure the frequency response of a wideband discriminator.

ACKNOWLEDGMENT

The 8406A Frequency Comb Generator was developed by Harley L. Halverson with the impulse generator portion designed by Richard W. Anderson. The mechanical design was done by Edgar C. Hurd.

—Roderick Carlson

SPECIFICATIONS

—hp— MODEL 8406A FREQUENCY COMB GENERATOR

COMB FUNDAMENTAL FREQUENCIES: 1, 10, and 100 MHz, pushbutton selected, generate harmonically related signals usable to beyond 5 GHz.

COMB FREQUENCY ACCURACY: $\pm 0.01\%$ (0° to 50°C).

PEAK AMPLITUDE (in terms of equivalent cw signal level as measured on —hp— Model 851B/8551B Spectrum Analyzer):

Comb	10-500 MHz	0.1-1 GHz	0.5-2 GHz	1-2 GHz	2-4 GHz
1 MHz	> -80 dBm	—	> -70 dBm	—	> -82 dBm
10 MHz	> -60 dBm	—	> -50 dBm	—	> -62 dBm
100 MHz	—	> -45 dBm	—	> -35 dBm	> -47 dBm

OUTPUT AMPLITUDE control permits continuous level adjustment.

COMB OUTPUT CONNECTOR: Type N female, source impedance approximately 50 ohms.

MAXIMUM PERMISSIBLE EXTERNAL SIGNAL AT COMB OUTPUT: Signals exceeding 1 watt (peak and average) at comb output may cause damage.

INTERPOLATION FUNCTION: 10 MHz and 1 MHz combs can be combined into primary-secondary comb; INTERPOLATION AMPLITUDE control adjusts level of secondary (1 MHz) signal.

EXTERNAL MODULATION: External modulation signals as low as 5 kHz can be used to phase modulate any comb to produce sidebands for interpolation between fixed comb markers. Level of modulation voltage required varies with modulating frequency and harmonic number of comb being modulated. As an example, to produce sidebands approximately 20 dB below main comb marker at 1 GHz harmonic of appropriate comb, typical modulation voltages are:

- 1–2 mV rms at 200 kHz for the 1 kHz comb.
- 5–10 mV rms at 2 MHz for the 10 MHz comb.
- 50–100 mV rms at 20 MHz for the 100 MHz comb.

Signals greater than 5 V rms at modulation input may cause damage. BNC female connector.

EXTERNAL TRIGGER: External signals (normally sine waves) between 1 and 200 MHz can be used to produce combs spaced at frequency of trigger signals. Typical input signal levels are in range of 1–3 volts rms. Input signals greater than 5 volts rms may cause damage.

OUTPUT AMPLITUDE control of 8406A can be used to adjust output comb level with input triggers in 1–20 MHz frequency span. Output comb amplitude is a function of input signal level when using signals in frequency span from 20 to 200 MHz. BNC female connector.

POWER: 115 or 230 volts $\pm 10\%$, 50 to 400 Hz, 2 watts.

SIZE: Nominally $5\frac{1}{8}$ in. wide by $6\frac{1}{2}$ in. high by 11 in. deep. (130 x 155 x 279 mm.)

WEIGHT: Net: 6 lbs. (2,7 kg). Shipping, 9 lbs. (4,1 kg).

PRICE: Model 8406A, \$500.00.
Prices f.o.b. factory

Data subject to change without notice

HP Archive

This vintage Hewlett-Packard document was
preserved and distributed by

www.hparchive.com

Please visit us on the web!

On-line curator: John Miles, KE5FX

jmiles@pop.net

