

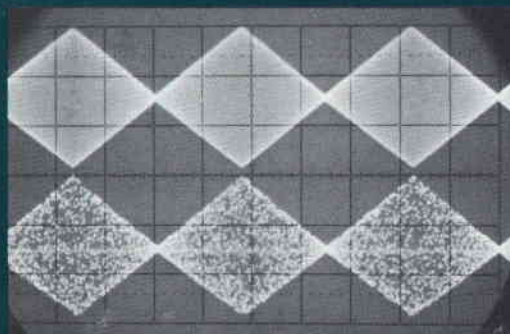

HEWLETT-PACKARD JOURNAL

TECHNICAL INFORMATION FROM THE *hp* LABORATORIES

CORPORATE OFFICES • 1501 PAGE MILL ROAD • PALO ALTO, CALIFORNIA 94304 • VOL. 17, NO. 11 JULY, 1966

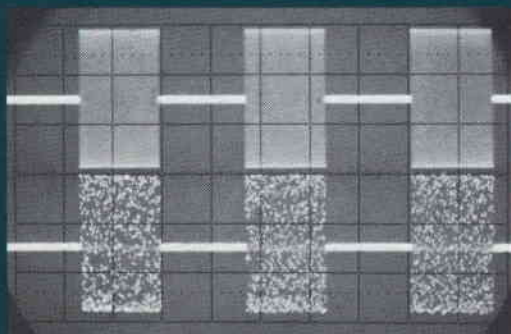
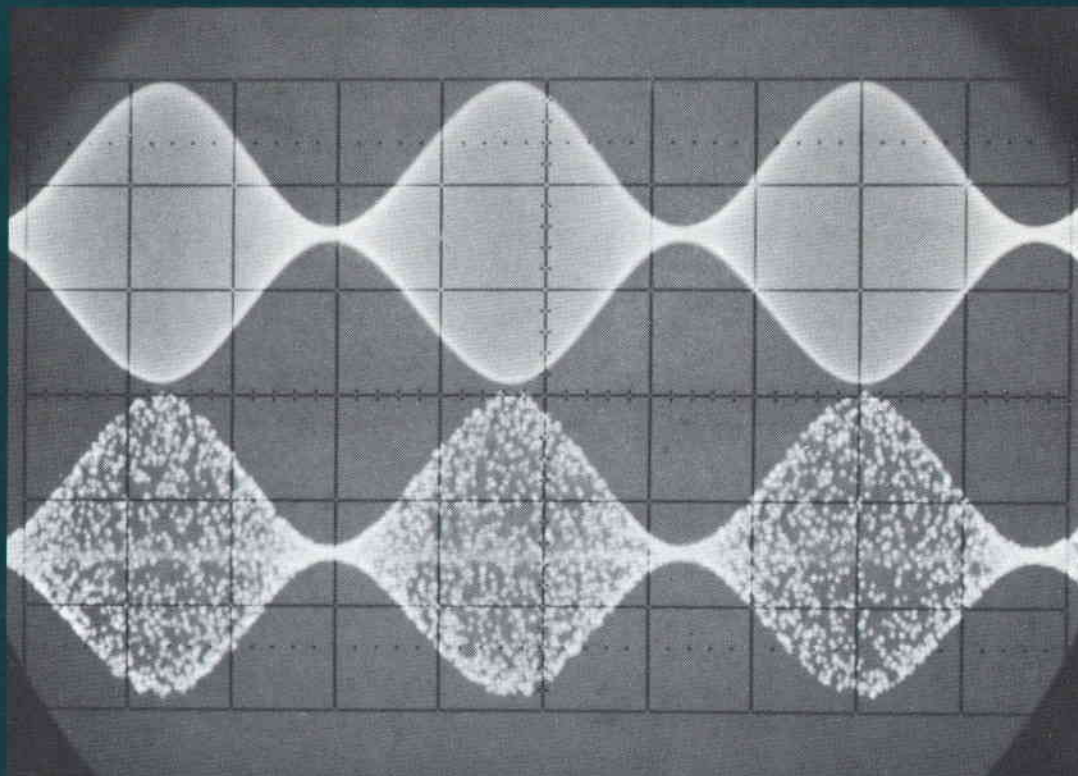

**COVER: NEW VOLTMETER MEASURES HF SIGNALS
BY INCOHERENT SAMPLING, p. 2**

**SEE ALSO: COHERENT AND INCOHERENT SAMPLING, p. 4
MEASURING SWR, p. 9
LOW-NOISE AMPLIFIER, p. 14**

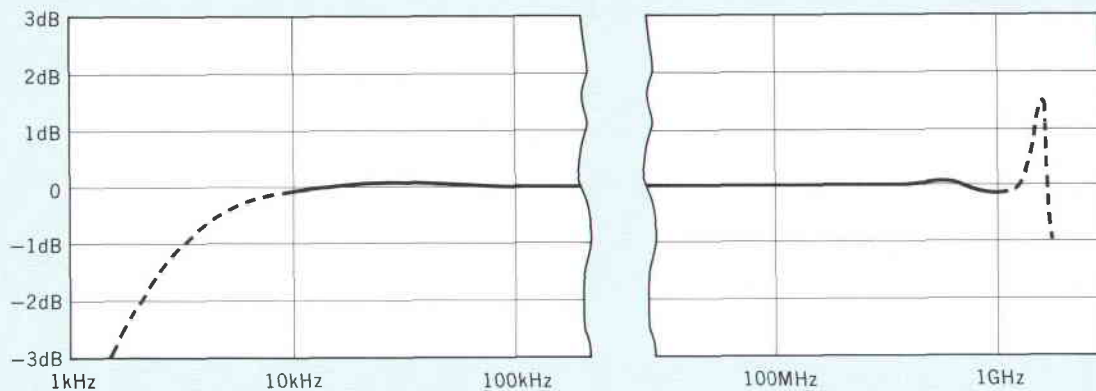

Fig. 1. Frequency response of typical production sampling voltmeter is flat within $\pm 1\%$ from 10 kHz to 1 GHz. Useful sensitivity extends from 1 kHz to over 2 GHz.

A SENSITIVE NEW 1-GHz SAMPLING VOLTMETER WITH UNUSUAL CAPABILITIES

A voltmeter operating on the principle of incoherent sampling measures over wide frequency and voltage ranges while providing an output usable for signal analysis.

SAMPLING HIGH-FREQUENCY WAVES in order to construct low-frequency equivalents of them is a powerful technique for observing and measuring broadband signals. The sampling oscilloscope,^{1,2} introduced about seven years ago, can display repetitive waveforms which contain frequency components up to several gigahertz. A more recent development, the RF vector voltmeter,³ can measure amplitudes and phase angles simultaneously and automatically at frequencies up to one gigahertz. Other sampling instruments are being investigated at *-hp-* for frequency

ranges as high as X band (12.4 GHz).

A sampling technique has been used by the *-hp-* Loveland Division to achieve exceptional sensitivity, frequency response, and accuracy in a new broadband voltmeter (Fig. 2). In addition to its basic voltage-measuring function, the sampling operation and flat frequency response of the new voltmeter give it many capabilities not found in more conventional RF millivoltmeters. Peak voltages, amplitude modulation envelopes, true rms values, pulse height information, and probability density functions of broadband

signals can be determined by observing the output of the sampling circuit. Much of this information has never before been accessible for broadband signals. Other uses for the instrument include broadband power measurements and leveling of the outputs of broadband signal generators.

¹Roderick Carlson, 'A Versatile New DC-500 MC Oscilloscope with High Sensitivity and Dual Channel Display,' *Hewlett-Packard Journal*, Vol. 11, No. 5-7, Jan.-Mar., 1960.

²Wayne M. Grove, 'A New DC-4000 MC Sampling Scope Plug-in with Signal Feed-Through Capability,' *Hewlett-Packard Journal*, Vol. 15, No. 8, April, 1964.

³Fritz K. Weinert, 'The RF Vector Voltmeter — An Important New Instrument for Amplitude and Phase Measurements from 1 MHz to 1000 MHz,' *Hewlett-Packard Journal*, Vol. 17, No. 9, May, 1966.



Fig. 2. Broadband sampling voltmeter, -hp- Model 3406A, has 50- μ V sensitivity, 20- μ V resolution, flat frequency response from 10 kHz to 1 GHz. Accuracy is $\pm 3\%$ to 100 MHz, $\pm 5\%$ to 700 MHz, $\pm 8\%$ to 1 GHz. Sampling circuit output is available on rear panel, giving instrument unusual capabilities for analysis of broadband signals.

The specified frequency range of the voltmeter is 10 kHz to 1 GHz, and the frequency response of a typical production instrument is flat within one percent over this range. Useful sensitivity extends from 1 kHz to 2 GHz or more. Voltage measurements are accurate within $\pm 3\%$ of full scale from 100 kHz to 100 MHz, $\pm 5\%$ from 10 kHz to 700 MHz, and $\pm 8\%$ to 1 GHz.

The sampling voltmeter responds to the absolute average values of unknown voltages, and is calibrated to read both the rms value of a sine wave and dBm in 50-ohm systems. It has eight voltage ranges from 1 mV full scale to 3 V full scale, and its sensitivity is high enough to measure voltages as small as 50 μ V. Voltage scales are linear, and resolution is 20 μ V on the 1 mV range.

Unlike some RF millivoltmeters, which are rms-responding on the lower ranges and gradually change to peak-detecting on the higher ranges, the new voltmeter is average-responding on all ranges. This means that its measurements of non-sinusoidal voltages are more accurate because its detector law does not change with the amplitude of the input signal. The absolute average value of any input signal can be determined simply by multiplying the meter reading by $\sqrt{8/\pi}$ (the ratio of absolute average to rms values of a sine wave).

Instead of the coherent, waveform-preserving sampling method used in most sampling instruments, the new voltmeter uses an incoherent technique which does not preserve the input waveform. In this type of sampling, which was developed in the -hp- Loveland Laboratory, the input voltage is sampled at irregular intervals which have no relationship to any of the frequency components of the input signal. Enough samples are taken, however, so that the average, peak, and rms values of the samples closely approximate the average, peak, and rms values of the input voltage. Thus the information that is relevant to the voltage-measuring function is preserved, while waveform, which is irrelevant, is not preserved. Details of both coherent and

incoherent sampling methods can be found on pages 4 and 5.

Incoherent sampling is especially advantageous in a voltmeter, because it gives the meter the sensitivity, accuracy, and broad frequency range of a sampling instrument, yet it is less costly than coherent techniques and, unlike coherent sampling, it does not require that the input signal be periodic. The sampling voltmeter operates equally well with sinusoidal, pulsed, random, or frequency-modulated signals.

The sampling circuit of the voltmeter is located in its probe, which is ac-coupled and permanently attached to the instrument with a 3-foot cable. Also located on the probe is a push-button which, when pressed, causes the voltmeter to retain its reading until the button is released. This memory system

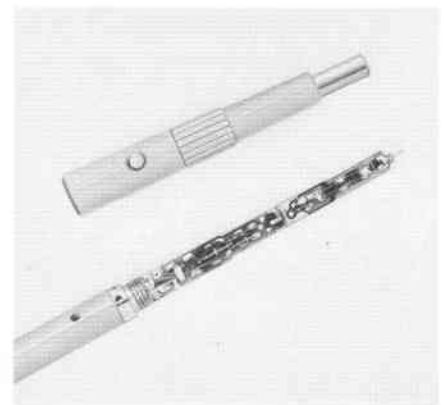

Fig. 3. Sampling probe assembly contains sampling-pulse generator and four-diode sampling bridge. Photo also shows pushbutton which, when depressed, causes meter to retain reading until button is released. This memory device eliminates need to hold probe in circuit and read meter at same time.

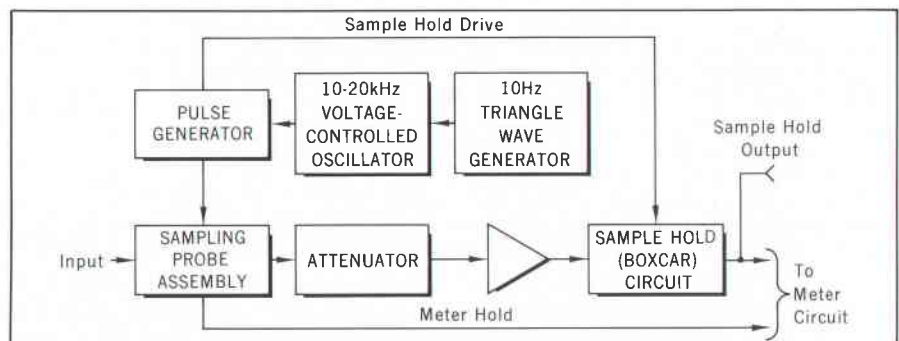

Fig. 4. Block diagram of sampling circuits of sampling voltmeter. Incoherent sampling is used, i.e., sampling intervals are not correlated with input signal. Incoherent intervals are generated by 'smearing' sampling rate from 10 kHz to 20 kHz at 10-Hz rate. Sample hold circuit retains constant voltage proportional to sample until next sampling instant.

simplifies measurements in awkward positions where it is difficult to place the probe and at the same time read the meter. Fig. 3 is a photograph of a disassembled probe, showing the sampling circuit and the memory push-button.

Other conveniences of the new voltmeter, besides the memory pushbutton already mentioned, include pushbutton range selection, rapid recovery from overloads, and a front-panel calibrator and zero receptacle. The meter recovers within five seconds from an overload of 30 V peak-to-peak (about 10,000:1 on its most sensitive, 1 mV

range). The front-panel receptacle allows the instrument to be zeroed in the presence of an RF field, or to be calibrated using its internal, 1 V $\pm 0.75\%$ calibrator.

SAMPLER OPERATION

Fig. 4 is a simplified block diagram of the sampling circuits. The incoherent sampling intervals are generated by 'smearing' the sampling rate. The basic sampling frequency is varied from 10 kHz to 20 kHz by a 10-Hz triangle wave. This sampling rate is uncorrelated with practically all input signals. (It is not uncorrelated with identical, phase locked waveforms, so

that voltages within the voltmeter cannot be measured.)

The 10-Hz triangular voltage varies the frequency of a voltage-controlled oscillator. The output of this oscillator drives a pulse generator which in turn triggers a sampling-pulse generator located in the probe. The sampling pulses, which are balanced pulses of approximately 250 picoseconds duration, turn on the diodes in a sampling bridge located in the probe, thereby allowing a sampling capacitor to charge to a voltage proportional to the input signal. The sampler output is a train of pulses whose amplitudes are

COHERENT AND INCOHERENT SAMPLING

Most sampling instruments, including the sampling oscilloscope and the vector voltmeter,* sample *coherently*. On the other hand, the broadband voltmeter described in the accompanying article samples *incoherently*. The reason for the difference is that most sampling instruments must preserve the waveform of an input signal, whereas the voltmeter needs only a measure of magnitude, such as the rms or the average value of the signal.

Coherent sampling is analogous to the familiar stroboscopic technique, by which an oscillating or repetitive motion is apparently 'slowed down' by observing it only at discrete times, instead of continuously. The observations, or samples, may be taken by flashing a light, by observing the oscillating object through a slit in a rotating disc, or by some other means.

Consider a stroboscopic observation of a tuning fork in motion. The apparent motion of the tuning fork can be made arbitrarily slow by adjusting the sampling rate, which in this case is either the rate at which the light flashes or the speed of rotation of the disc. The tuning fork may vibrate back and forth many times between glimpses, but so long as its position on each glimpse is only slightly advanced from its position on the preceding one, it seems to be moving much more slowly than it really is. If the slow motion were recorded on movie film it would, of course, be possible to determine the peak, the average, and the rms values of the tuning fork's excursions from its center position.

*See footnotes, p. 2.

This could be done simply by measuring the excursion on each frame of film and computing the peak, average, and rms values of the resulting collection of samples by standard techniques.

Now, if the film were cut apart and then spliced back together randomly, all time-sequence information about the movement of the tuning fork would be lost. However, certain information would be retained. The peak excursion would not change, and a little reflection will show that the average and rms values of the excursions would also be the same. In

fact, even information about the probability of the fork's being at a given excursion would be retained. The same information could have been obtained by randomly flashing the light or by randomly opening a shutter. So long as a sufficient number of pictures were taken, the peak, average, and rms excursions could still be found. This kind of sampling, in which statistics are preserved but time-sequence information is not preserved, is *incoherent* sampling.

The difference between coherent and incoherent sampling for a high-frequency

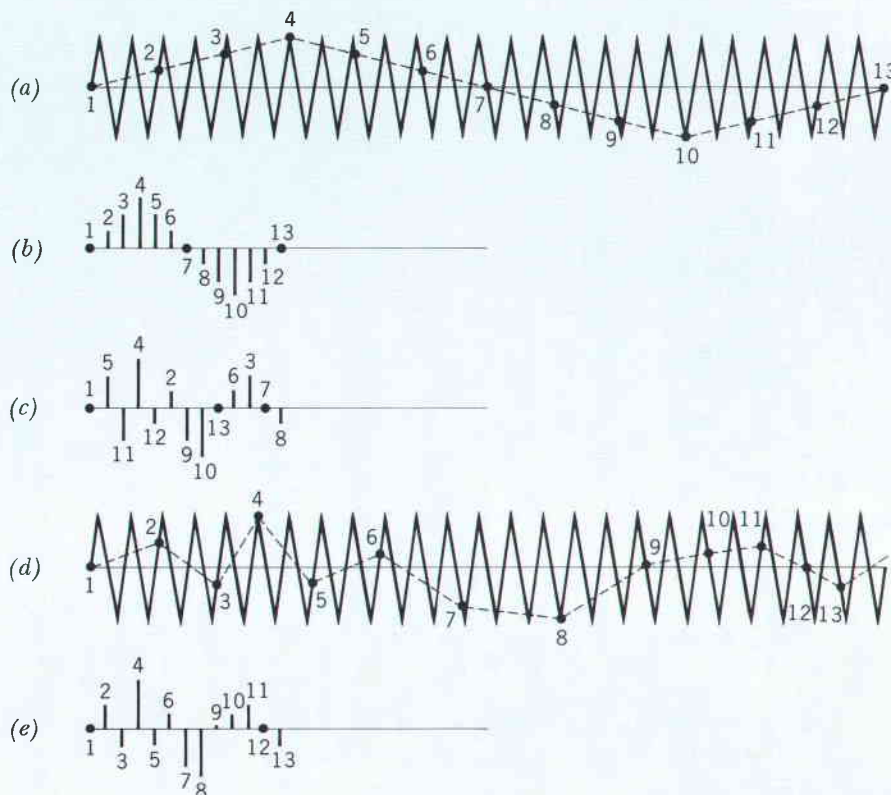

proportional to the input voltage at the sampling instants.

The output of the sampler is fed through attenuators and amplifiers to the 'boxcar' circuit, which is a zero-order hold with clamp (modified pulse-stretcher). The bandwidth of the cable and amplifiers is narrow compared to the bandwidth of the sampling pulses, so by the time the samples reach the boxcar circuit, they have become pulses of about 5 microseconds duration, similar to the pulses illustrated in Fig. 5.

The boxcar circuit output is clamped to ground for 2 microseconds following the sampling pulse and then

wave is shown in illustrations (a) through (e). In (a), samples are taken at regular intervals, and at such a rate that a lower-frequency equivalent of the original signal can be reconstructed from the samples. In (b) the samples are shown with their correct amplitudes, polarities, and relative phases (order). In (c) the same samples are shown scrambled, so that only their amplitudes and polarities are preserved. The average, peak, and rms values of the (c) group are the same as the average, peak, and rms values of the (b) group.

In (d) the original high-frequency wave is shown sampled incoherently. The interval between samples is not constant, and the waveform cannot be reconstructed from the samples, which are shown at (e). However, the group of samples in (e) is statistically equivalent to the groups of samples in (b) and (c). So long as all three groups contain a large enough number of samples, they have the same peak, average, and rms values.

In order for the technique of incoherent sampling to work in all situations it is necessary that there be no correlation between the sampling times and the motion or signal under observation. If the sampling frequency were a subharmonic of the frequency of the motion or signal being measured the motion would be completely stopped; thus, all of the samples would have exactly the same height and it would be impossible to determine the peak, average, rms, and so on.

In the new broadband sampling voltmeter, the basic sampling signal is frequency-modulated by a 10-Hz triangular wave, so that the sampling frequency varies between 10 kHz and 20 kHz, at a 10-Hz rate. This produces non-uniform sampling intervals which are, for all practical purposes, uncorrelated with all input signals.

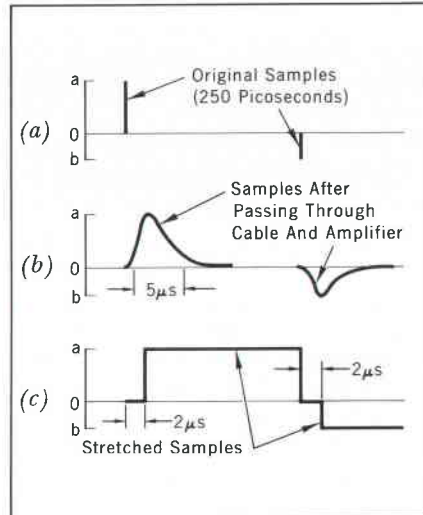

Fig. 5. Sampling pulses which open sampling gate in probe are approximately 250 picoseconds wide, as shown in (a). When samples reach sample hold circuit after passing through cable and amplifier, they are about 5 μ s wide, as shown in (b). Sample hold output is clamped to zero volts for 2 μ s following each sampling instant, then becomes constant voltage proportional to sample.

becomes a steady voltage that is proportional to the height of each sample taken. The output of this circuit is available from a connector at the rear of the instrument and is labeled 'Sample Hold Output'.

FREQUENCY RESPONSE

The exceptionally flat frequency response of the sampling voltmeter is shown in Fig. 1. This response was measured in a 50-ohm system, with the

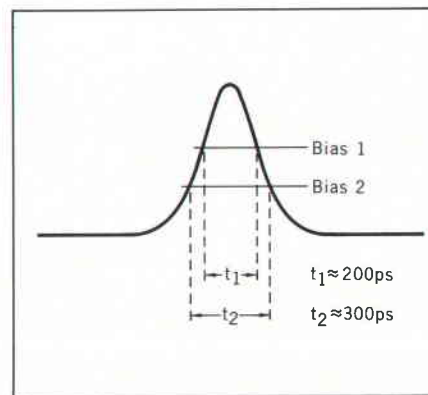

Fig. 6. Width of sampling pulse is adjusted by changing bias on sampling gate in probe. High-frequency response of voltmeter can be adjusted in this way, since wider pulses mean lower cut-off frequency, and vice versa.

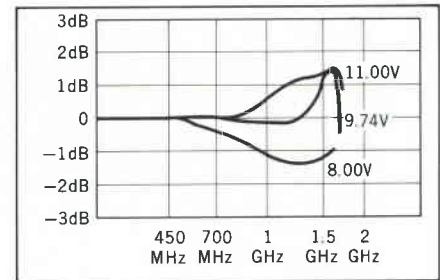

Fig. 7. Effect on high-frequency rolloff of changing bias on sampling gate in probe (see Fig. 6).

sampling probe inserted in a 50-ohm tee. Broadband or high-frequency measurements would normally be made in this configuration. At lower frequencies, probing would probably be done by hand, and the probe would be equipped with a divider or an isolator (see Specifications).

In production instruments, the high-frequency response is adjusted for optimum flatness by changing the bias on the sampling bridge in the probe. Since the sampling pulse does not have vertical leading and trailing edges, reducing the bridge bias makes the pulse wider, and vice versa (see Fig. 6). Wider pulses result in lower high-frequency response. The probe by itself tends to peak at the high frequencies, so very close cancellation can be obtained by making the sampling pulse longer. Fig. 7 shows the frequency response of a typical production instrument as a function of sampling bridge bias.

Temperature variations produce very little change in the flatness of the frequency response. Fig. 8 shows the environmental performance of the response of a typical production unit.

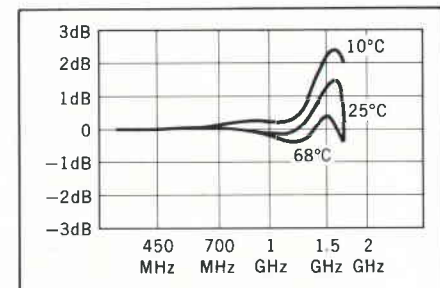

Fig. 8. High-frequency response of sampling voltmeter is relatively insensitive to temperature changes. Temperature variation from 10°C to 68°C produces only $\pm 2\%$ changes in 1-GHz response.

SAMPLE HOLD OUTPUT INFORMATION

The sample hold output voltage is a low-frequency pulse train which, despite the lower frequency and difference in waveshape, has the same average, peak, and rms values as the input signal. This output makes it possible, therefore, to obtain information about broadband signals by using only low-frequency instruments. Fig. 9 shows oscillograms of typical sample hold outputs for sinusoidal and random input signals having frequency components up to 1 GHz.

Amplitude modulation envelopes can be observed at the sample hold output if the modulation frequency is sufficiently low compared to the sampling frequency, which is 10-20 kHz. Modulation envelopes can be observed with any low-frequency oscilloscope (e.g., -hp- Model 130C) for carrier frequencies up to 2 GHz or more and modulating frequencies up to 1 or 2 kHz. Oscillograms of typical displays are shown in Fig. 10.

Peak measurements and pulse-height analyses may also be made by observing the sample hold output with a low-frequency oscilloscope. The crest factor of the input signal can be as high as 10 (4.5 on 1 V range, 1.4 on 3 V range)

without affecting the calibration of the sample hold output.⁴

If a true-rms-reading voltmeter is connected to the sample hold output, the true rms value of the input signal can be measured. Previously, high-frequency true-rms measurements could only be made with a power meter, which is much less sensitive than a voltmeter. Conventional RF millivoltmeters can also measure true rms values for small signals, but these voltmeters gradually change to peak detectors as the amplitude of the input signal increases, whereas the detector law of the sampling voltmeter is the same on all ranges. The sampling voltmeter is also more sensitive than a conventional instrument.

The statistics of the unclamped portion of the sample hold output closely approximate the statistics of the input signal. Consequently, it is possible to determine the statistical characteristics of broadband signals by applying appropriate low-frequency techniques to the sample hold output. For example, the probability density and probability distribution of, say, random noise with

⁴Crest factor of an ac waveform is the ratio of its peak voltage to its rms voltage; e.g., a crest factor of 10 for an ac pulse waveform corresponds to a duty cycle of 0.01. See 'The Significance of Crest Factor,' *Hewlett-Packard Journal*, Vol. 15, No. 5, Jan. 1964.

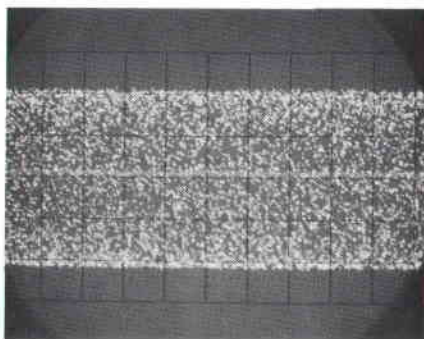

(a)

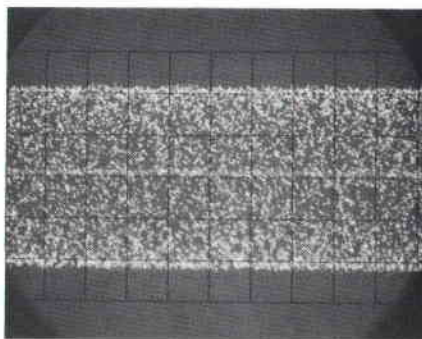

(b)

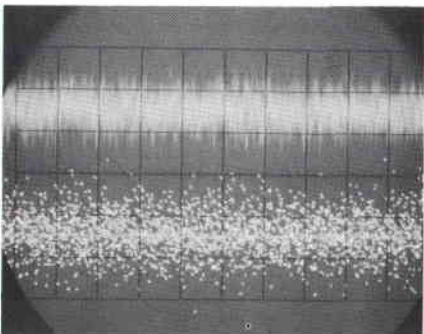

(c)

Fig. 9. Time-exposure oscillograms of sample hold output of sampling voltmeter. Sample hold signals are statistically equivalent to input signals, but can be observed and measured with low-frequency instruments. Input signals were (a) 1-MHz sine wave, (b) 1-GHz sine wave, (c) random noise with upper frequency limit of 150 MHz. Upper trace in (c) shows noise input to voltmeter corresponding to sample hold output shown in lower trace. Noise source was two cascaded amplifiers.

1-GHz bandwidth can be determined by analyzing the sample hold output. Probability information, of course, is helpful in dealing with any signal, but it is especially necessary when the signal is random. Yet, up to now it has often been neglected or assumed, because of the impossibility of measuring it for broadband signals.

DC OUTPUT AND POWER MEASUREMENTS

With its probe inserted in a 50-ohm tee, the voltmeter can monitor the voltage across a 50-ohm load, and power readings can be taken directly from the dBm scale. Power levels as small as one nanowatt can be measured in this way. Hence the sampling voltmeter is a much more sensitive power monitor than the more conventional power meter and directional coupler.

In addition to the sample hold output, the sampling voltmeter also has a dc output at which a dc voltage proportional to the meter reading is available. This output is primarily for driving a recorder but, because of the very flat frequency response of the voltmeter, it also has other uses.

Using the voltmeter to monitor the voltage across a load, leveled voltage output over the 10-kHz-to-1-GHz range can be obtained from any signal generator which operates in this range and has a dc modulation input. The dc output of the voltmeter is fed back through appropriate shaping networks to the dc modulation input of the signal generator, causing the generator output to be as constant as the frequency response of the voltmeter.

METER CIRCUITS

Fig. 11 is a block diagram of the meter circuits. The output of the box-car circuit is detected and filtered to produce a dc voltage which is a measure of the absolute average value of the input signal. The output signal-to-noise ratio of an average-reading detector is a nonlinear function of the input signal-to-noise ratio,⁵ so the gain of the detector for the average value of

⁵This nonlinearity is different from that of a typical diode detector, which is a square-law device for small signals and a linear device for large signals. The detector in the sampling voltmeter is linear, and the nonlinearity is caused by the presence of the noise. See W. R. Bennett, 'Response of a Linear Rectifier to Signal and Noise,' *Bell System Technical Journal*, Vol. 23, No. 1, Jan. 1944. See also B. M. Oliver, 'Some Effects of Waveform on VTVM Readings,' *Hewlett-Packard Journal*, Vol. 6, No. 10, June, 1955.

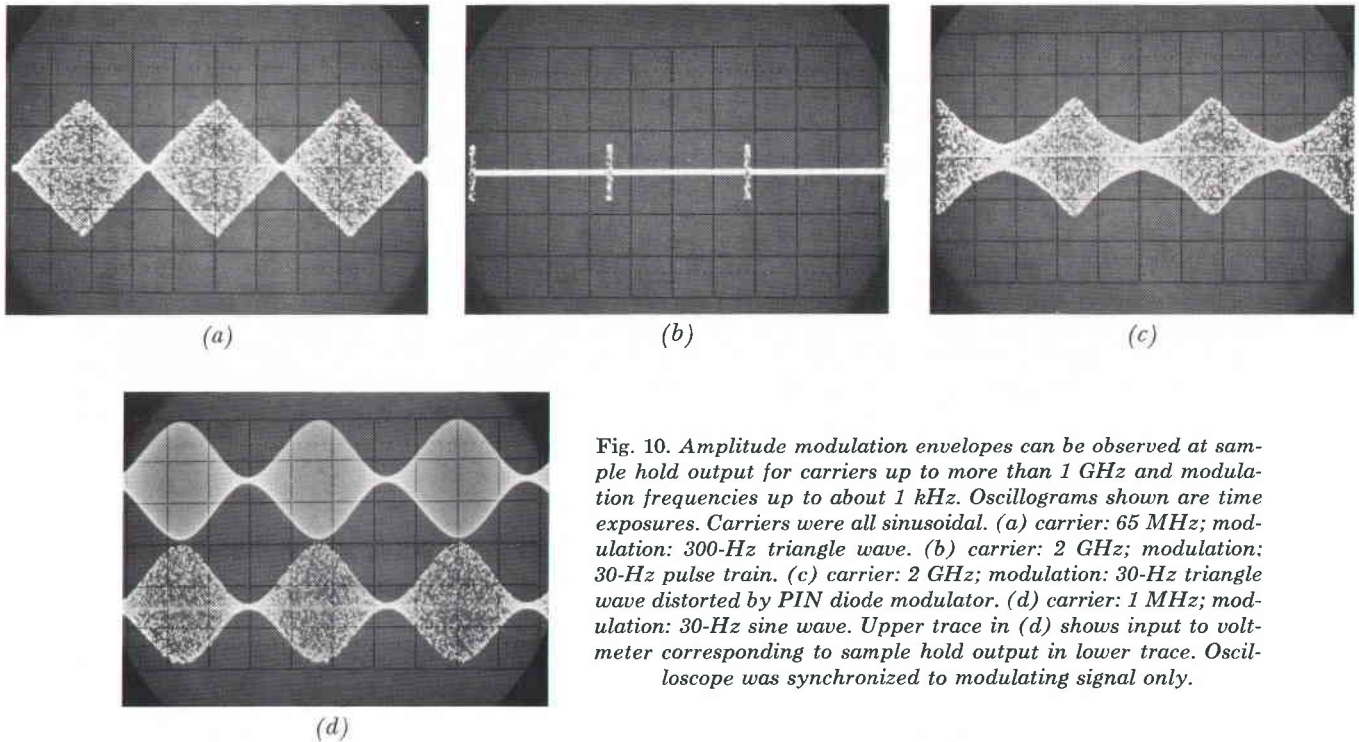

Fig. 10. Amplitude modulation envelopes can be observed at sample hold output for carriers up to more than 1 GHz and modulation frequencies up to about 1 kHz. Oscillograms shown are time exposures. Carriers were all sinusoidal. (a) carrier: 65 MHz; modulation: 300-Hz triangle wave. (b) carrier: 2 GHz; modulation: 30-Hz pulse train. (c) carrier: 2 GHz; modulation: 30-Hz triangle wave distorted by PIN diode modulator. (d) carrier: 1 MHz; modulation: 30-Hz sine wave. Upper trace in (d) shows input to voltmeter corresponding to sample hold output in lower trace. Oscilloscope was synchronized to modulating signal only.

the signal is nonlinear. To make the meter's voltage scales linear, a non-linear circuit is placed between the detector and the meter. The resulting gain is essentially constant from 50 μV to full scale.

Noise in voltmeters often causes considerable meter jitter and loss of sensi-

tivity and linearity on the lower ranges. These effects have been greatly reduced in the sampling voltmeter. On the one millivolt range, the inherent noise of the system plus thermal noise amounts to about 150 to 200 microvolts. This noise is not dependent upon the source impedance of the signal being meas-

ured. It has an essentially constant mean value, so its effects on meter readings can be corrected easily. The mean value of the noise is subtracted from the output in a noise suppression circuit, thereby giving the voltmeter much greater sensitivity.

Since the noise is random and the

DESIGN LEADERS



JOHN T. BOATWRIGHT

John Boatwright received his BS degree in electrical engineering from Massachusetts Institute of Technology in 1960. He continued his studies while working with a firm in Cambridge, and then joined -hp- in 1961 as a development engineer. He is now an engineering section manager in the development laboratory of the -hp- Loveland Division. John holds several patents in the field of space communications, and has a patent pending on random sampling.

Ron Tuttle received his BS de-



RONALD K. TUTTLE

gree in chemical engineering and his MS degree in electrical engineering from the University of California at Berkeley in 1959 and 1961, respectively. After joining the -hp- Frequency and Time Division in 1961, he worked as a circuit designer on the 5260A Frequency Divider project. In 1964 he transferred to the -hp- Loveland Division, where he has contributed to the design and testing of the 3406A Sampling Voltmeter.

Fred Wenninger received his BS degree in physics, and his MS and



FRED W. WENNINGER, JR.

PhD degrees in engineering from Oklahoma State University in 1959, 1962, and 1963. He joined the -hp- Loveland Division in 1963, and since 1965 he has been an engineering group leader at Loveland. He has a patent pending on random sampling. Prior to his joining -hp-, Fred's professional activities included micrometeorite research, satellite instrumentation design, and development of an electronic brain stimulator. He also served for several years as a part-time instructor in mathemat-

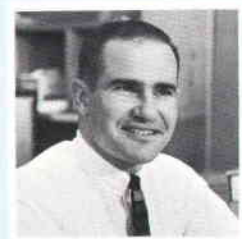

ROGER L. WILLIAMS

ics and physics at Oklahoma State.

Roger Williams joined the -hp- Loveland Division in 1963 as a summer student, after receiving his BS degree in engineering from Harvey Mudd College. He subsequently worked with -hp- in Palo Alto while continuing his studies at San Jose State College. In 1964, he returned to the Loveland Division, and did the product design work for the 3406A Sampling Voltmeter. Roger is continuing his studies towards the MS degree at Colorado State University.

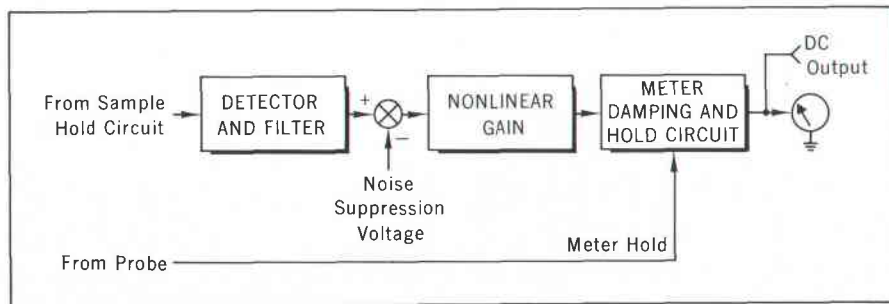

Fig. 11. Block diagram of meter circuits of sampling voltmeter. Instrument is average-responding on all voltage ranges. Damping and noise-cancellation circuits reduce effects of noise. Nonlinear gain circuit gives meter linear voltage scales.

gain of the circuit is highest when the signal is smallest, the meter would be very jittery if damping were not introduced. However, damping sufficient to reduce the jitter to a usable level would cause the response to be very sluggish. For this reason, a nonlinear damping circuit is employed. The nonlinear damping circuit provides heavy damp-

ing for small variations in the input and drastically reduces the meter jitter due to noise. The damping is decreased for large variations in the input signal, so that the overall response of the instrument is fairly rapid.

Because a finite number of samples are taken in any given time interval, there is a certain variance in the sam-

ple hold output, and the nonlinear damping serves to reduce meter jitter due to this effect as well as that due to noise. The pushbutton memory circuit mentioned earlier is also incorporated in the nonlinear damping circuit.

ACKNOWLEDGMENTS

The sampling voltmeter is the direct result of a late-hour discussion between John T. Boatwright and the author. Mr. Boatwright, who is now a section manager in the Loveland Laboratory, provided substantial contributions in the initial stages of the project. Ronald K. Tuttle designed the accessories and contributed in the circuit design area. Roger L. Williams was responsible for the product design.

Special credit is also due Marco R. Negrete, Loveland Laboratory manager, Ronald W. Culver, engineering aid, and B. M. Lovelace, production engineer.

—Fred W. Wenninger, Jr.

SPECIFICATIONS

-hp-

MODEL 3406A BROADBAND SAMPLING VOLTMETER

VOLTAGE RANGE: 1 mV to 3 V full scale in eight ranges; decibels from -50 to +20 dBm (0 dBm = 1 mW into 50 ohms); absolute average-reading instrument calibrated to rms value of sine wave.

FREQUENCY RANGE: 10 kHz to 1 GHz; useful sensitivity from 1 kHz to beyond 2 GHz.

FULL-SCALE ACCURACY WITH CALIBRATOR:
±3%, 100 kHz-100 MHz
±5%, 10 kHz-700 MHz
±8%, 5 kHz-1 GHz
±1 dB, 4 kHz-1.2 GHz
±4 dB, 2 kHz-1.5 GHz

INPUT IMPEDANCE: 100,000 ohms at 100 kHz. Capacity approximately 2 pF. Input capacity and resistance will depend upon accessory tip used. (approximately 8 pF with 11072A isolator tip supplied.)

SAMPLE HOLD OUTPUT: Provides ac signal whose unclamped portion has statistics that are narrowly distributed about the statistics of the input, inverted in sign (operating into >200 kΩ load with <1000 pF).

Noise:

Typically 175 μV rms.

Accuracy with Calibrator:

0.01 V Range and Above: Same as full-scale accuracy of instrument.

0.001 V to 0.003 V Range: Value of input signal can be computed by taking into account the residual noise of the instrument (see references in footnote 5, p. 6).

Jitter:

Typically ±2% peak of reading (with -hp- Model 3400A true-rms voltmeter connected to Sample Hold Output).

Crest Factor:

0.001 V to 0.3 V: 20 dB full scale (inversely proportional to meter indication); 1 V: 13 dB; 3 V: 3 dB.

DC RECORDER OUTPUT: Adjustable from zero to 1.2 mA into 1000 ohms at full scale, proportional to meter deflection.

METER:

Meter scales: Linear voltage, 0 to 1 and 0 to 3; decibel, -12 to +3. Individually calibrated taut-band meter.

Response Time: Indicates within specified accuracy in <3 s.

Jitter: ±1% peak (of reading).

GENERAL:

Calibrator Accuracy: ±0.75%.

Overload Recovery Time: Meter indicates within specified accuracy in <5 s. (30 V p-p max.)

Maximum Input: ±100 Vdc, 30 V p-p.

RFI: Conducted and radiated leakage limits are below those specified in MIL-I-6181D and MIL-I-16910C except for pulses emitted from probes. Spectral intensity of these pulses is approximately 50 nV/√Hz; spectrum extends to approx. 2 GHz.

Temperature Range:

Instrument 0°C to +55°C.

Probe +10°C to +40°C.

Power: 115 or 230 volts ±10%, 50 Hz to

1000 Hz, approximately 17 watts.

Dimensions: Standard ½ module 6½ in. high, 8⅞ in. wide, 11½ in. deep (165 x 225 x 292 mm).

WEIGHT: Net, 12 lbs. (5.4 kg); Shipping, 15 lbs. (6.8 kg).

PRICE: \$650.00.

ACCESSORIES

ACCESSORIES FURNISHED: 11072A isolator tip, 8710-0084 nut driver for tip replacement, 5020-0457 replacement tips, 10213-62102 ground clips and leads.

ACCESSORIES AVAILABLE:

11064A Basic Probe Kit \$100.00 consists of the following:

11063A 50-ohm 'T'.

11061A 10:1 divider tip.

10218A BNC adapter.

0950-0090 50-ohm termination.

11071A Probe Kit \$185.00 consists of all the above plus:

11073A Pen-type probe,

10219A Type 874A adapter.

10220A Microdot adapter.

11035A Probe-tip kit.

11061A: 10:1 Divider

As well as dividing the input voltage by a factor of ten this accessory eliminates the effects of source impedance variations.

Accuracy (divider alone):

±5% 1 kHz to 400 MHz.

±12% 400 MHz to 1 GHz.

Max. Input: 150 V p-p ac; 600 V dc.

11063A 'TEE': Should be used whenever measurements are made in 50Ω systems.

VSWR: ≤1.15 at 1 GHz (bare probe in tee).

Useful to about 1.5 GHz.

Insertion Power Loss: <4% up to 1 GHz.

11072A: Isolator

Essentially eliminates effects of source impedance variations.

Increases probe capacitance by approximately 6.5 pF. Recommended frequency range is 10 kHz to 250 MHz.

11073A: Pen-type Isolator

Recommended frequency range is 10 kHz to 50 MHz. Various accessories adapt the 11073A to alligator jaws and other tips which facilitate point-to-point measurements. Increases probe capacity by approximately 7 pF.

10218A: Probe-to-Male-BNC Adapter

Recommended frequency range is 10 kHz to 250 MHz.

Prices f.o.b. factory.

Data subject to change without notice.

MEASURING ATTENUATION, SWR, AND SUBSTITUTION LOSS WITH A LOW-NOISE, HIGH-PRECISION SWR METER

Effects of noise and other factors are presented for an improved SWR Meter used with crystal and bolometer type detectors.

MANY USEFUL MICROWAVE PARAMETERS, such as standing-wave ratio (SWR), substitution loss,¹ insertion loss, attenuation, and gain, are ratios of two signal levels. The relative power levels which determine these parameters can often be measured most conveniently and accurately by means of a versatile audio-frequency instrument known as a standing-wave-ratio meter.

The SWR meter consists of a high-gain (over 100 dB) audio amplifier which has a selective bandpass frequency response, followed by an indicating meter which is calibrated for SWR and relative power measurements. Fig. 1 shows two typical SWR-meter applications. For substitution-loss measurements [Fig. 1 (a)], a microwave carrier, amplitude modulated by an audio-frequency signal, is applied to the attenuator under test. (The modulating signal is usually a square wave and the modulation index is usually 100%, because other modulating waveforms sometimes cause undesirable frequency modulation of the microwave source.) A square-law detector, usually a crystal diode or bolometer, produces an audio-frequency voltage proportional to the RF power at the attenuator output. The SWR meter amplifies the fundamental component of the audio-frequency detector output and indicates its strength on a scale which is calibrated in dB relative to whatever reference level has been chosen for the measurement. The reference level, of course, is established before the attenuator is inserted into the circuit. For SWR measurements [Fig. 1 (b)] the setup is similar, except that the SWR meter is used as an indicator for a detector mounted on the probe of a slotted line, and readings are taken from a scale which is calibrated in SWR.

A more sensitive, more accurate

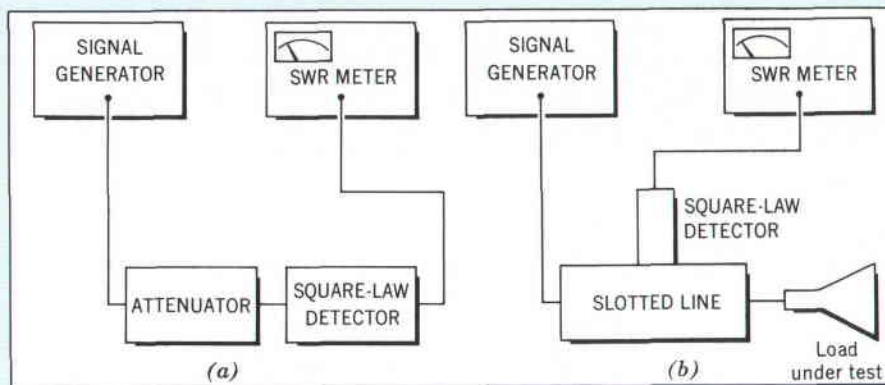

Fig. 1. (a) Block diagram of substitution-loss-measuring setup using SWR meter. RF signal-generator output is amplitude modulated by an audio-frequency square wave. Square-law detector produces an audio-frequency output voltage proportional to the RF power. SWR meter amplifies and measures the audio signal. (b) SWR measurement setup, with SWR meter used as the indicator for a slotted line.

SWR meter (Fig. 2) has now been developed by the *-hp-* Microwave Division. Because of its low noise figure, precision attenuators, and high gain stability, this SWR meter is able to make many measurements which previously were possible only with far more complicated and more costly devices. To demonstrate the instrument's potential and to provide a guide to its most effective use, a great deal of useful information gathered during the SWR meter's development is summarized later in this article.

The SWR meter has a noise figure specification of less than 4 dB, an improvement of 6 to 10 dB over previous models. As a result, its dynamic range is greater, because it can make measurements at lower RF power levels than were practical with earlier versions. Rated sensitivity of the instrument is $0.15 \mu\text{V rms}$ for full-scale deflection at maximum bandwidth, or $1 \mu\text{V rms}$ if the detector is a high impedance crystal. When its gain and bandwidth are set for rated sensitivity, the meter's noise level is at least 7.5 dB below full scale.

Because of its low noise figure, the

new meter is able to exploit fully the sensitivity of the newest detectors. Its ability to operate with lower input power also increases its accuracy in certain measurements on non-linear solid-state devices: the SWR of a microwave detector at high power, for example, is different from its SWR at the low power at which it normally operates.

Accuracy of the SWR meter's attenuators has also been improved. The RANGE attenuator is variable from 0 to 60 dB in 10-dB steps, and is accurate within ± 0.05 dB per step. Its maximum cumulative error is ± 0.10 dB.

For increased resolution, there is an EXPAND attenuator which allows any 2-dB portion of the instrument's 70-dB range to be displayed full-scale on the indicating meter. A meter reading of -56.18 dB, for example, can be read with maximum resolution by switching the RANGE attenuator to 50 dB and the EXPAND attenuator to 6 dB, and reading the remaining 0.18 dB on the 0-2 dB EXPAND scale of the meter. The maximum cumulative error of the EXPAND attenuator is ± 0.05 dB.

The indicating meter is accurate within ± 0.02 dB, so the absolute max-

¹ Robert W. Beatty, 'Insertion Loss Concepts,' IEEE Proceedings, Vol. 52, No. 6, June, 1964. Also Hewlett-Packard Application Note No. 56.



Fig. 2. —hp— Model 415E SWR Meter has scales calibrated in dB and SWR for use with square-law detectors. Instrument has noise figure less than 4 dB when used with common crystal or bolometer detectors. Attenuators are accurate within ± 0.15 dB.

imum cumulative error from the attenuators and the meter is only ± 0.17 dB over the 70-dB range.

The operating frequency of the new SWR meter is nominally 1000 Hz, but it is adjustable over a 7% range so that the meter can be tuned precisely to the signal generator modulation frequency. Bandwidth is adjustable from 15 Hz to 130 Hz, the narrowest bandwidth resulting in maximum signal-to-noise ratio and maximum usable sensitivity, and the widest bandwidth allowing swept-frequency measurements and oscilloscope presentation. The filter which gives the amplifier its selectivity is a specially designed active filter

which keeps the amplifier gain approximately constant as the bandwidth is varied.

Feedback stabilization of the amplifier has been employed to eliminate 'drift,' or gain changes caused by variations in line voltage, frequency, or temperature. Drift in a typical production instrument over a 24-hour period has been observed to be only 0.03 dB. This means that once a reference level has been set, it need not be checked periodically.

The new SWR meter has both ac and dc outputs so that it can be used as a high-gain (126 dB), 1000-Hz ac amplifier or to drive a recorder. The dc

level of the ac output voltage is zero and does not change with signal amplitude; this simplifies oscilloscope presentations.

The input circuitry of the instrument is designed to operate with unbiased low-impedance or high-impedance detectors, or to supply bias currents of 4.5 mA or 8.7 mA for bolometer detectors. The bias currents are held constant within $\pm 3\%$ so that no adjustment is necessary for individual bolometers. The input ground is connected to the circuit ground, and is isolated by a resistor from the chassis (power-line) ground. This attenuates the effects of ground-loop voltages so that they will rarely if ever be a problem.

The new meter is all solid state, and can be battery operated.

STUDY OF SWR METER PRECISION

In the course of the development and testing of the SWR meter, much information was gathered concerning the accuracy of measurements made with the SWR meter in combination with typical crystal and bolometer detectors. Some of this information was obtained from technical papers and some was obtained from laboratory measurements. Since few readers have

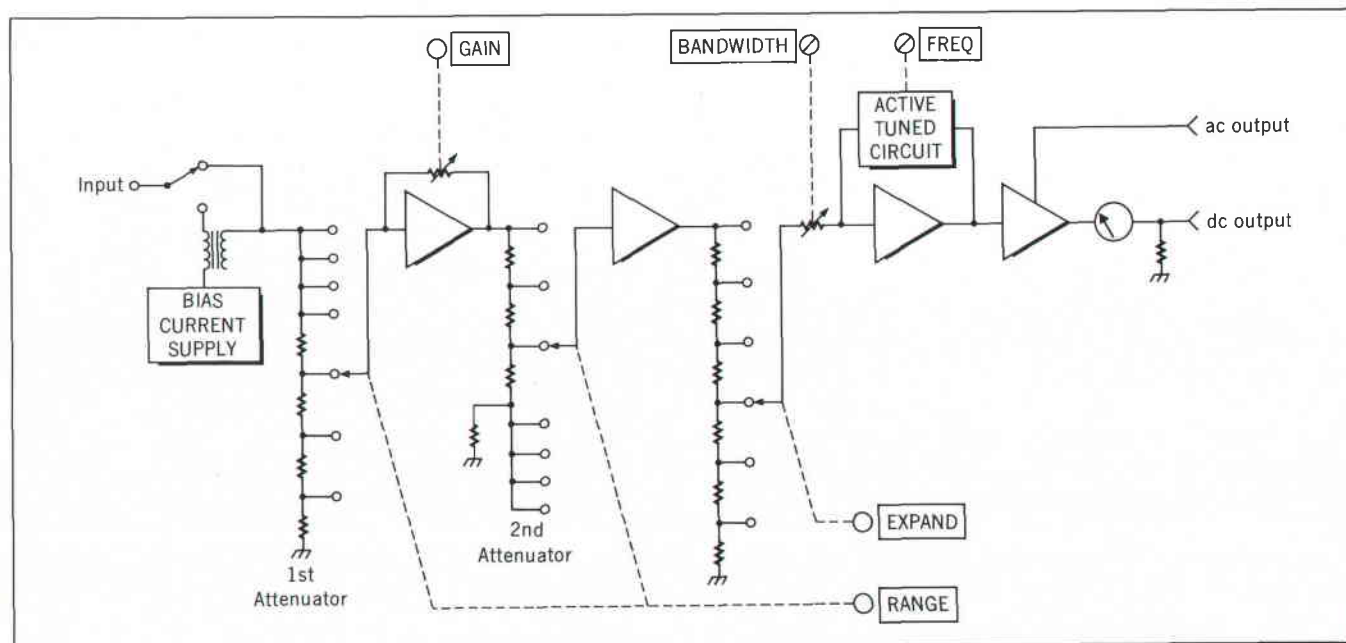

Fig. 3. Block diagram of —hp— Model 415E SWR Meter. First attenuator is used only for the 0, 10, and 20-dB positions of the RANGE switch. Second attenuator is used in 30, 40, 50, and

60-dB positions. This design preserves signal-to-noise ratio by first amplifying, then attenuating small signals. Input amplifier has very low noise. All amplifiers have feedback-stabilized gain.

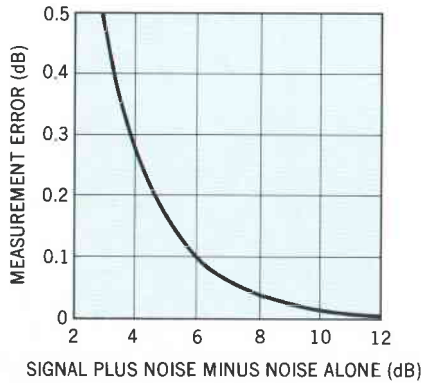

Fig. 4. Error due to noise in *-hp-* Model 415E SWR Meter readings. Error is shown as a function of difference between signal-plus-noise meter reading and noise-alone (RF source disconnected) meter reading. E.g., if signal-plus-noise reading minus noise reading is 8 dB, then signal-plus-noise reading is 0.05 dB higher than correct reading for signal alone.

the opportunity to conduct such a study, some of the important results are summarized here. Topics treated are: noise figure and its effect on accuracy at low power, deviations from square law of typical detectors at high power, and the effects of temperature on the square-law behavior of crystals. These results should be of considerable value to readers who need a high degree of precision in attenuation, SWR and substitution-loss measurements.

NOISE AND NOISE FIGURE

The SWR meter is designed to operate with square-law detectors such as bolometers (e.g., barretters²) and crystals. At low RF power levels, noise generated in the detector and in the amplifier determines the lower limit on the dynamic range of the detector and meter.

The effects of noise on average meter readings are somewhat systematic and predictable. Noise causes the meter to read too high by the amounts shown in Fig. 4. These errors have been calculated for the type of meter circuit used in the *-hp-* SWR meter. To use Fig. 4 to estimate the effects of noise on meter indications, the RF source should be turned off after each measurement and a second reading taken on the noise alone. Fig. 4 is a plot of the difference between these two readings versus the

corresponding measurement error in the first reading. For example, if a reading of signal plus noise is 8 dB above the reading obtained with noise alone, then the original signal-plus-noise reading is about 0.05 dB higher than the correct value for signal alone.

A useful measure of the sensitivity of an SWR meter is its noise figure. Noise figure (in dB) of an SWR meter is twice the difference between the actual meter indication (in dB) and the calculated meter indication (in dB) for a noiseless SWR meter with the same source impedance. The factor of two is necessary because the meter is calibrated for square-law detectors.

An unbiased detector like a crystal diode has a noise voltage which is the same as the thermal noise voltage that would be calculated for an equivalent resistor of the same video impedance. For a diode detector, therefore, the lower limit on the dynamic range of the SWR meter is set by its noise figure. An instrument with a noise figure which is 6 dB lower than that of another instrument will have a noise level which is also about 6 dB lower. This corresponds to 3 dB on the SWR meter and 3 dB in RF power at the detector input, because of the square-law calibration.

Biased detectors like barretters generally have a noise-temperature ratio greater than one and generate noise voltages which are large compared to the noise contributed by the SWR meter. A measurement comparing a

200-ohm barretter with a 200-ohm metal film resistor showed that the SWR meter noise level with the barretter was approximately 2 dB higher than with the resistor. This means that the noise level of the SWR meter with a barretter detector is determined primarily by the barretter. However, the meter with the lowest noise figure will still have the lowest noise level, because amplifier noise power and detector noise power are additive.

The noise figure of the new meter has been optimized for the source impedances presented by the square law detectors most often used with SWR meters. The noise figure of the instrument is typically less than 4 dB when the detector has an optimum impedance, which is about 5000 ohms with the meter's INPUT switch in the high-impedance position and about 100 ohms otherwise. The noise figure varies slowly with source impedance, and system performance will not be impaired seriously by the use of detectors whose impedances vary from the optimum by a factor of 2 to 1. Fig. 5 shows typical behavior of the noise figure of the meter as the source impedance changes.

As an example of how the low noise figure of the new meter enables it to make accurate measurements of very small signals, suppose that meter gain is set for a full-scale sensitivity of 1.0 μ V, that bandwidth is set at the minimum value (15 Hz), and that the detector impedance is 5000 ohms. With these settings, a 5-dB meter reading will be

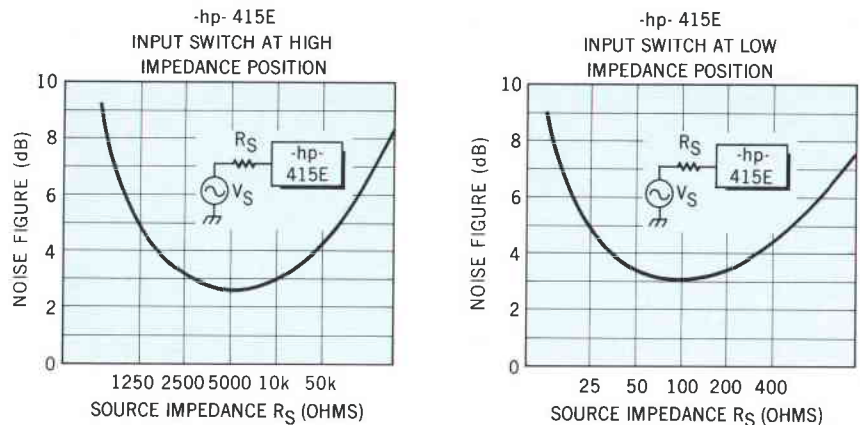

Fig. 5. *-hp-* Model 415E noise figure vs. detector source impedance. Noise figure is defined as twice the difference between actual meter reading and calculated meter reading for noiseless SWR meter with same source impedance.

² A barretter is a resistive element with a positive temperature coefficient of resistance. Its resistance increases when it absorbs power.

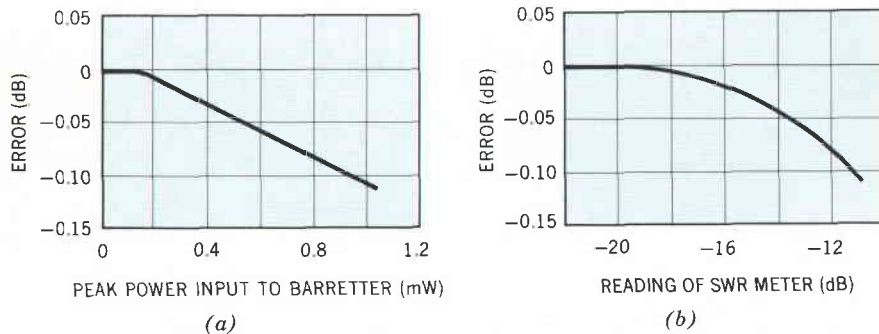

Fig. 6. Measured errors in readings of -hp- Model 415E SWR Meter caused by deviation of barretter detector from square law. (a) Error in reading of SWR meter vs. peak input power to barretter. (b) Error in reading of SWR meter vs. reading of SWR meter. RF signal amplitude modulated by 1-kHz square wave; modulation index, 100%.

in error by less than 0.1 dB. This 5-dB reading corresponds to only $0.316 \mu\text{V}$ at the input of the SWR meter, or to a peak RF power of -57.6 dBm for a detector with a sensitivity of $4 \text{ mV}/\mu\text{W}$ (a typical value).

SQUARE-LAW ERRORS AT HIGH POWER LEVELS

Bolometers and crystals begin to deviate from square-law operation when their video outputs become large. The -hp- Model 423A Crystal Detector,³ for example, deviates up to $\pm 0.5 \text{ dB}$ from square law at a video output of 50 millivolts peak, when operated with a special load which is designed to extend its square-law range.

Although 0.5 dB is a reasonably small error, it is a large error compared to the inherent errors of the new SWR meter. The sensitivity of the SWR meter makes it possible to operate crystal detectors at much lower video outputs, where they follow a true square law much more closely. Normally, it will be possible to operate the crystal in a region where its errors contribute less than .05 dB. For example, the deviation from square law of the -hp- Model 423A Crystal Detector without any special load will be less than $\pm 0.05 \text{ dB}$ for about 2 millivolts peak output or about 1 millivolt rms. Special square-law loads are not very effective at eliminating small errors of 0.05 dB or less, especially when a range of temperatures is encountered. Consequently, at video outputs of a few millivolts or less, a crystal is a good square-law device con-

nected directly to the input of the SWR meter.

For barretters, the upper limit on square-law performance is determined by several factors.⁴ First, square-law error may be increased if the input impedance of the SWR meter is low. In substitution-loss and attenuation measurements there may be a second error at high power levels caused by changes in the reflection coefficient of the barretter. Still another error, called biasing error, is dependent upon the type of dc bias supplied to the barretter. To determine the effect on SWR-meter readings of these barretter square-law errors, a set of measurements was taken.

The measurement setup was designed to minimize microwave mismatch errors, and the SWR meter was carefully calibrated to eliminate attenuator and meter errors. Thus the errors measured were the sum of all of the square-law errors just mentioned.

Results are shown in Fig. 6. Fig. 6(b) shows the error in the readings of the SWR meter as a function of the meter readings and Fig. 6(a) shows the error in the meter readings as a function of the peak power input to the barretter. Total square-law error was less than 0.05 dB for a 100%-square-wave-modulated RF signal having a peak power of about $500 \mu\text{W}$, or -3 dBm . The SWR meter at this point read approximately -13 dB which corresponded to $7 \mu\text{V}$ rms at the meter input. If a user is operating a barretter detector below these levels, he can be confident that

⁴ G. U. Sorger and B. O. Weinschel, 'Comparison of Deviations from Square Law for RF Crystal Diodes and Barretters,' IRE Transactions on Instrumentation, Vol. I-8, No. 3, Dec., 1959.

the barretter is a good square-law device.

DYNAMIC RANGE

Fig. 7 shows the useful ranges of the SWR meter when used with a typical crystal diode detector and a typical barretter detector. As discussed above, the limits on dynamic range are determined by noise at low power levels and square-law errors at high power levels.

The measurements for Fig. 7 were made with the SWR meter set for minimum bandwidth (15 Hz). They indicate that, although the crystal makes a more sensitive detector by about 8 dB, the dynamic range of the meter is greater with the barretter detector. Dynamic range for a maximum error of $\pm 0.05 \text{ dB}$ was 32 dB for the crystal, 49 dB for the barretter. These values are for two specific detectors, of course. To determine the limits of the measurement range of any crystal or bolometer detector when used with the -hp- SWR meter at minimum bandwidth, simply measure the meter noise level in dB (meter reading with no RF input to detector). Then add 8 dB to determine the lower limit of the measurement range (e.g., if noise level is -68 dB , lower limit is -60 dB). For a crystal, add 32 dB to this lower limit to determine the upper limit (e.g., if lower



BRADFORD G. WOOLLEY

Gil Woolley joined -hp- in 1963 as a development engineer in the -hp- Microwave Division, after receiving AB and BSEE degrees from Brown University. He participated in the design of the 789C Directional Coupler and the 788C Directional Detector, and more recently in the final stages of the design of the 415E SWR Meter, paying particular attention to the environmental performance of the 415E. His current projects are concerned with broadband power measurement using lumped and distributed circuitry. Gil is also working towards his MSEE degree at Stanford University.

³ The -hp- Model 423A is a wideband, high-sensitivity crystal detector, designed to operate between 10 MHz and 12.4 GHz.

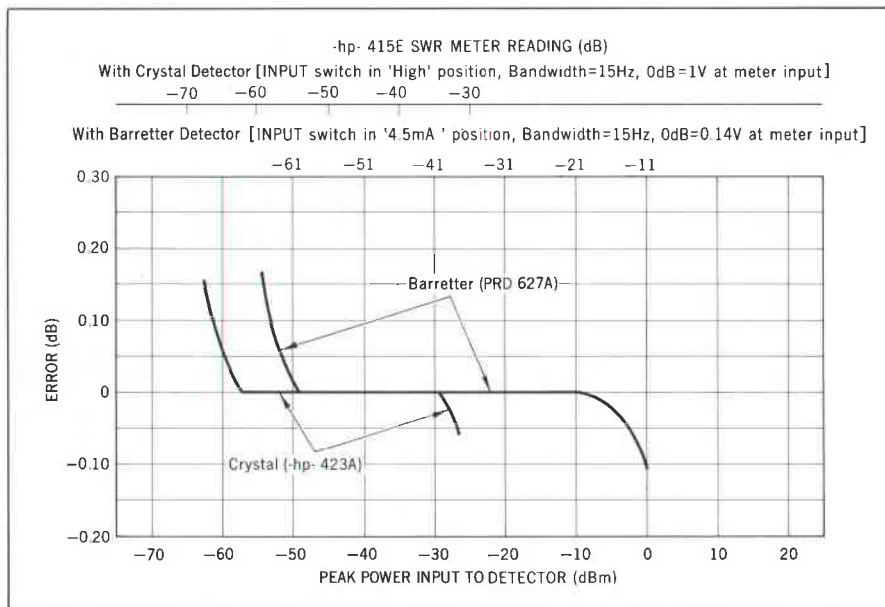

Fig. 7. Measurement range of -hp- Model 415E SWR Meter extends to lower power levels than were previously usable because meter has low noise figure. Range is limited at low power levels by detector and meter noise and at high power levels by deviation of detector from square law. Curves show errors in meter readings due to these two sources for typical crystal and barretter detectors. Errors are shown as a function of peak RF power input to detector (RF signal 100% amplitude modulated by 1-kHz square wave) and as a function of meter readings. Note that crystal detector is more sensitive, but dynamic range of barretter is greater.

limit is -60 dB, upper limit is -28 dB). For a barretter, the upper limit is 49 dB above the lower limit. Conservative practice may suggest decreasing the upper limit by one or two dB.

Errors caused by other system uncertainties would probably exceed these meter errors in most setups. Assume, for example, that the substitution-loss setup of Fig. 1 (a) is used to measure the attenuation of a 20-dB attenuator. In such a setup, there are almost always source, attenuator, and detector mismatches. If each mismatch produces an SWR of 1.5 (a typical value), the measured attenuation may be in error by one dB.⁵ The accuracy of the new SWR meter, therefore, is more than adequate for most applications.

EFFECT OF TEMPERATURE ON CRYSTAL DETECTORS

A crystal detector operated in the square-law region, that is, at low power levels, produces a voltage V_o at the input of the SWR meter which is proportional to the crystal input power P_{in} . The constant of proportionality is inversely proportional to the absolute

⁵ Hewlett-Packard Application Note No. 56.

temperature T . Thus, in the square-law region,

$$\frac{V_o}{P_{in}} = \frac{a}{T}$$

where a is a constant which depends upon the characteristics of the crystal.

The crystal retains its square-law characteristics with temperature changes, and no measurement error is introduced so long as the temperature of the crystal does not change between the setting of the SWR-meter reference level and the measurement of the unknown power.

If the crystal temperature changes between the reference setting and the measurement, the measurement will be in error by an amount which depends on the magnitude of the temperature shift. A change in T from 293°K to 323°K (20°C to 50°C), for example, will cause an error of

$$\frac{T_1}{T_2} = \frac{293}{323} = 0.907 = -0.42 \text{ dB}$$

Normal laboratory temperature variations of 2 or 3°C will cause less than .04 dB error.

— Bradford G. Woolley

SPECIFICATIONS

-hp- MODEL 415E SWR METER

SENSITIVITY: 0.15 μ V rms for full-scale deflection at maximum bandwidth (1 μ V rms on high impedance crystal input).

NOISE: At least 7.5 dB below full scale at rated sensitivity and maximum bandwidth with input terminated in optimum source impedance (100 ohms or 5000 ohms). Noise figure less than 4 dB.

RANGE: 70 dB in 10- and 2-dB steps.

ACCURACY: ± 0.05 dB/10 dB step, maximum cumulative error between any two 10-dB steps, ± 0.10 dB; maximum cumulative error between any two 2-dB steps, ± 0.05 dB. Linearity: ± 0.02 dB on expand scales, determined by inherent meter resolution on normal scales.

INPUT: Unbiased low and high impedance crystal (50-200 and 2500-10,000 ohm optimum source impedance respectively for low noise); biased crystal (1 V into 1 k); low and high current bolometer (4.5 and 8.7 mA $\pm 3\%$ into 200 ohms) positive bolometer protection. Input connector, BNC female.

INPUT FREQUENCY: 1000 Hz, adjustable 7%. Other frequencies between 400 and 2500 Hz available on special order.

BANDWIDTH: Variable, 15 to 130 Hz. Typically less than 0.5 dB change in gain from minimum to maximum bandwidth.

RECORDER OUTPUT: 0 to 1 V dc into an open circuit from 1000 ohms source impedance for ungrounded recorders. Output connector, BNC female.

AMPLIFIER OUTPUT: 0 to 0.3 V rms (NORM), 0 to 0.8 V rms (EXPAND) into at least 10,000 ohms for ungrounded equipment. Output connector, dual banana jacks.

METER SCALES: Calibrated for square-law detectors. SWR: 1 to 4, 3.2 to 10 (NORM); 1 to 1.25 (EXPAND). DB: 0 to 10 (NORM); 0 to 2.0 (EXPAND). Battery: charge state.

METER MOVEMENT: Taut-band suspension, individually calibrated mirror-backed scales; expanded dB and SWR scales greater than 4¼ in. (108 mm) long.

RFI: Conducted and radiated leakage limits are below those specified in MIL-I-6181D.

POWER: 115 or 230 volts $\pm 10\%$, 50 to 400 Hz, 1 watt. Optional rechargeable battery provides up to 36 hours continuous operation.

PRICE: -hp- Model 415E, \$350.00.

OPTIONS:

01. Rechargeable battery installed, add \$100.00
02. Rear-panel input connector in parallel with front-panel connector, add \$15.00.

Prices f.o.b. factory
Data subject to change without notice

INCREASING INSTRUMENT SENSITIVITY WITH A LOW-NOISE PREAMPLIFIER

A guide to a number of applications in which measurements are simplified by a low-noise wide-band amplifier.

EXTENDING THE USEFUL RANGE OF INSTRUMENTS down into the microvolt range requires a stable preamplifier with a low noise level, high output and wide dynamic range. A new general-purpose amplifier designed to amplify low level signals has a typical noise level of $15 \mu\text{V}$ and a bandwidth of 1 megahertz. Either 20 dB or 40 dB gain can be selected. Frequency response is less than 2 dB down from 5 Hz to 1 MHz; output is greater than 10 volts rms open circuit and greater than 5 volts rms into 50 ohms ($\frac{1}{2}$ watt). This combination of high output, low noise and wide bandwidth gives the amplifier a wide dynamic range—72 dB in the 40 dB gain position, and 92 dB at the 20 dB gain setting. These characteristics coupled with a 10-megohm, 15-pF input, make the amplifier useful in a wide range of applications, especially those applications where low noise level is essential.

Low noise in the amplifier is achieved with a field-effect transistor (FET). As shown in Fig. 2, the FET drain load is boot-strapped by the second stage, an emitter-follower, to increase the effective drain load resistance, and hence obtain a gain of 40 dB in the FET.

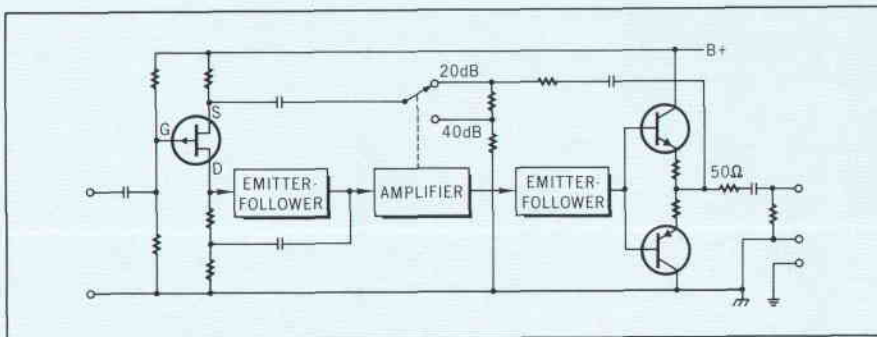
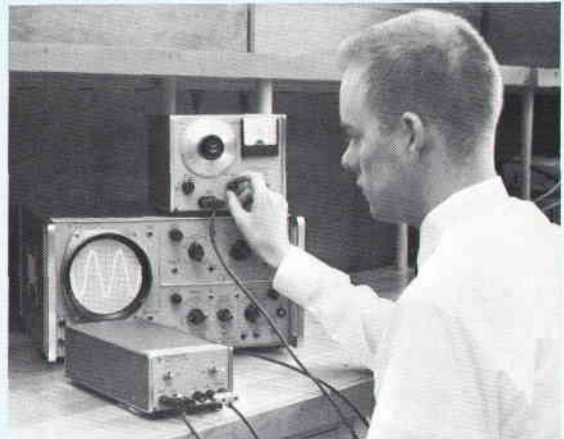

Fig. 2. As shown in the block diagram of the general purpose amplifier, negative feedback from the output is injected into the FET source to stabilize amplifier gain and insure linearity. Overall gain is changed by switching the feedback ratio.

Fig. 1. —hp— Model 465A low noise amplifier, lower left, has a voltage gain of 20 dB or 40 dB and a frequency response of ± 0.1 dB from 100 Hz to 50 kHz. Input impedance is 10 megohms shunted by less than 20 pF; output impedance is 50 ohms with 5 volts rms output into a 50 ohm load. Noise is less than $25 \mu\text{V}$ rms referred to the input with 1 megohm source resistance.



The emitter-follower also drives a second amplifier stage which in turn is followed by an emitter-follower driving a complementary-symmetry output stage. The output impedance of the amplifier is essentially zero ohms and is raised to 50 ohms by a fixed resistor. Following are some typical applications which take advantage of the characteristics of this amplifier.

LOW NOISE APPLICATIONS

Noise performance of amplifiers and power supplies is usually presented as a plot of noise amplitude versus frequency. Data for this plot is obtained

with a wave analyzer at the output of the unit under test. When measuring noise in the nanovolt region, it is necessary to increase system sensitivity by amplifying the noise output. Parametric amplifiers have been specially designed for low frequency applications. They can be used to increase sensitivity of a noise measurement system, and a further increase can be obtained by adding the low noise amplifier following the paramp. Output noise of the paramp is relatively constant over its bandwidth, but the noise of the amplifier drops rapidly at increasing frequency, with its input shorted.

In a specific application, Fig. 3, the output noise of a 2 Hz to 100 KHz parametric amplifier used was 400 nV/

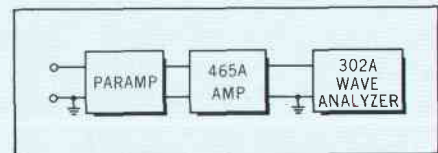

Fig. 3. Narrow band analysis of noise as a function of frequency requires a wave analyzer. The wave analyzer bandwidth is only 6 Hz and more gain for low noise measurements can be obtained by using a parametric amplifier and the general purpose amplifier.

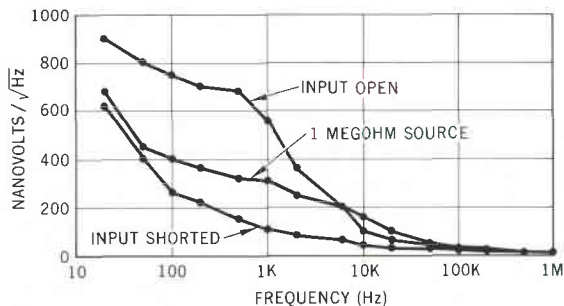

Fig. 4. Noise spectrum of the general purpose amplifier in nanovolts per root cycle referred to the input.

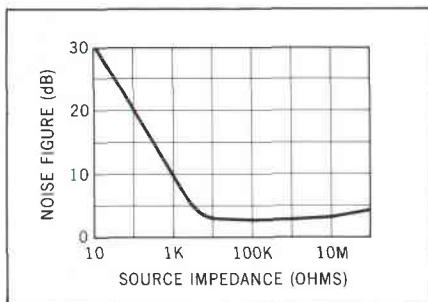

Fig. 5. Noise figure plot of the -hp-465A shows that the source impedance for best noise performance is from 100 kilohms to 1 megohm.

$\sqrt{\text{Hz}}$ and the paramp output presents a nearly shorted source to the amplifier. Under these conditions, the noise in the amplifier drops below 400 nV/ $\sqrt{\text{Hz}}$ above 50 Hz, Fig. 4. Thus adding the amplifier to the system increases gain with no noise contribution from the preamplifier above 50 Hz.

In some measurements it is desirable to use a transformer instead of a parametric amplifier to match impedance levels so that the general purpose amplifier is operated at an optimum source impedance for lowest noise performance. In Fig. 5, this impedance is in the range from 100 k to 1 megohm. Noise characteristic for a 1-megohm source is shown in Fig. 4.

More important, however, the use of a properly designed step-up transformer increases gain with no increase in noise.

If a 1:30 step-up transformer is used, the effective noise of the amplifier referred to the input is divided by 30 over the entire frequency range of the transformer. Care must be taken in using a transformer to avoid pickup of external fields.

DIODE NOISE MEASUREMENT

In production, selection of diodes for a sampling gate according to their noise when reverse biased is accomplished with the simple test set-up, Fig. 6. Measurements are made with an rms voltmeter to get true rms value of diode noise. Overall system noise of this scheme is 10 μV . Acceptable diodes had noise voltages less than 20 μV .

The same test set-up, with appropriate filter and proper shielding could be used to measure transistor noise or noise in other components to a level as low as 2 μV .

UNITY GAIN IMPEDANCE CONVERTER

The new general-purpose amplifier can be used as an impedance converter, Fig. 7. On the 20 dB position with its normal 10-megohm input, the amplifier provides a 10-ohm output at 1 volt rms (a) and 1-ohm output impedance at 0.1 volt rms (b). For very high impedance input, the circuit at (c) provides a 100-megohm, 2 pF input. The trimmer is used to provide unity gain through the amplifier on the 20 dB

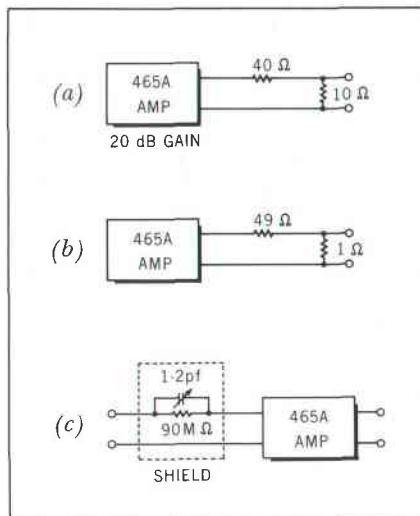

Fig. 7. Input impedance of the -hp-465A is 10 megohms with a 50-ohm output. Output impedance can be made 10 ohms (a), 1 ohm (b), or input impedance can be 100 megohms by circuit (c) in the 20 dB position, thus allowing impedance matching at unity gain.

position, and the impedance converter will have a frequency response similar to the basic amplifier.

MEDIUM POWER OSCILLATORS

Maximum output of the -hp- Model 204B, 208A, and 241A solid-state Oscillators is 10 mW into a 600-ohm load. Their output power can be increased 14 times into a 600-ohm load with the amplifier, or by a factor of 180 into a



Fig. 6. Wide dynamic range of the general purpose amplifier is used to best advantage in diode noise measurement tests with an rms voltmeter. Crest factor of the input waveform is maintained and the amplifier noise contribution to the system is insignificant.



ROBERT B. BUMP

Bob Bump received his BSEE in June, 1962, from California Institute of Technology. He joined the -hp- Loveland Division as a development engineer in July, 1962. Since that time, he has worked on the -hp- Model 208A Test Oscillator and the -hp- Model 465A Amplifier. He also conducted some investigation projects on amplifiers.

Presently, Bob is attending Colorado State University on the -hp- Cooperative Honor's Program. He expects to receive his MSEE from that school in December, 1966.



Fig. 8. Output of low power test oscillators can be increased sufficiently to drive a loudspeaker if desired.

50-ohm load, Fig. 8. The amplifier can drive a loudspeaker if desired.

TEN-WATT, 1-MHz AMPLIFIER

When the new amplifier is cascaded with the *-hp-* Model 467A Power Amplifier, Fig. 9, the combination achieves 10 watt peak power output, an overall stable gain of 60 dB, a 1-MHz frequency response, and the low-noise, high-impedance input of the new amplifier.

VOLTMETER PREAMPLIFIER

Sensitivity of a 10-mV voltmeter, such as the *-hp-* Model 427A can be increased to 1 mV directly at the 20 dB gain setting of the amplifier, Fig. 10. It may also be extended to 100 μ V full scale at the 40 dB setting by adding a bandpass filter between the amplifier and the voltmeter. Similarly, a 1-mV voltmeter can be extended to 100 μ V by using the 20 dB gain setting.

Sensitivity of a digital a-c voltmeter can also be extended while maintaining useful accuracy. Frequency re-



Fig. 9. Cascading the *-hp-* 467A Power Amplifier with the amplifier results in a stable 60-dB amplifier with 10-megohm input impedance and 10 watts peak power output.

sponse of the amplifier is within 1% from 100 Hz to 50 kHz, thus increasing resolution of a digital voltmeter, such as the *-hp-* 3445, to a 1 mV rms.

OSCILLOSCOPE PREAMPLIFIER

As an oscilloscope preamplifier, the amplifier provides a 10-megohm, 15-pF input without the use of a probe. An oscilloscope with a sensitivity of 0.05 V/cm (0.5 V/cm with probe) will have a sensitivity of 5 mV/cm with the amplifier on the 20 dB gain position or 0.5 mV/cm on the 40 dB position. In the latter position, noise is only 0.2 cm.

DISTRIBUTION AMPLIFIER

Low output impedance of the amplifier is advantageous for driving several loads simultaneously, Fig. 11, or for driving long cables. The amplifier has been used as a distribution amplifier to supply a precision 100 kHz time base simultaneously to several counters.



Fig. 10. A 10 mV voltmeter such as the *-hp-* Model 427A can be extended to read 1 mV full scale with the amplifier gain set at 20 dB.

ACKNOWLEDGMENT

The *-hp-* 465A Amplifier was designed under the direction of Noel Pace. Product design was by Kay Danielson and electrical design by the undersigned.

—Robert B. Bump

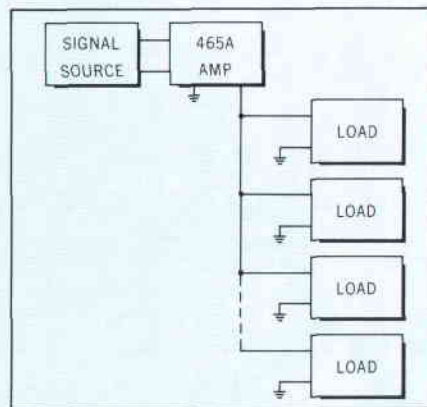

Fig. 11. Low output impedance of the *-hp-* Model 465A permits driving several loads in parallel, such as several counters simultaneously from an external precision time base.

SPECIFICATIONS

-hp- MODEL 465A AMPLIFIER

VOLTAGE GAIN: 20 dB (X10) or 40 dB (X100), open circuit.

GAIN ACCURACY: ± 0.1 dB ($\pm 1\%$) at 1000 Hz.

FREQUENCY RESPONSE: ± 0.1 dB, 100 Hz to 50 kHz <2 dB down at 5 Hz and 1 MHz.

OUTPUT: >10 volts rms open circuit; >5 volts rms into 50 ohms ($\frac{1}{2}$ watt).

DISTORTION: <1%, 10 Hz to 100 kHz, <2%, 5 Hz to 10 Hz and 100 kHz to 1 MHz.

INPUT IMPEDANCE: 10 megohms shunted by <20 pF.

OUTPUT IMPEDANCE: 50 ohms.

NOISE: <25 μ V rms referred to input (with 1 megohm source resistance).

TEMPERATURE RANGE: 0 to +50°C.

POWER: 115 or 230 V $\pm 10\%$, 50 to 1000 Hz, 10 watts at full load.

WEIGHT: Net: 4 lbs. (1.8 kg). Shipping: 6 lbs. (2.7 kg).

DIMENSIONS: $\frac{1}{3}$ module, $5\frac{1}{8}$ in. wide, $3\frac{1}{2}$ in. high, 11 in. deep (130 X 87 X 279 mm).

PRICE: \$190.00.

Prices f.o.b. factory
Data subject to change without notice

AT WESCON—

WIDEBAND SAMPLING SESSION

Translation of frequency using wideband sampling techniques has extended traditional low-frequency measurement methods into the microwave region. Sampling is now becoming more important with the application of phase-locked-loops to sampling instruments, thus opening new ways of measuring 'vector voltage' and complex impedance.

The use of sampling for electronic instrumentation will be discussed by four *-hp-* authors at a contributed technical session at

OTHER *-hp-* PAPERS

Also at WESCON/66, M. M. Atalla of *-hp-* Laboratories will review the state of the art and assess the future of Schottky barriers and their applications as discrete devices and in integrated circuits. Schottky barrier diodes are already in use in a number of high frequency applications and many new devices based in the concept will soon become available. Title of Dr. Atalla's paper is 'Metal Semiconductor Schottky Barriers and Devices'. It will be pre-

WESCON/66. Session chairman Dr. Bernard M. Oliver, *-hp-* vice-president for research and development, will outline progress made in the past few years in adapting sampling techniques to extending instrument bandwidths. Papers will cover various aspects of sampling.

WESCON/66 will be in Los Angeles this year from August 23rd through 26th. The *-hp-* technical session will be Friday, August 26th, from 9:30 to 12:00 noon in the Biltmore Hotel Renaissance Room.

sented Tuesday morning, August 23rd, in the Biltmore Hotel Ballroom.

Another *-hp-* author, John C. Beckett, will present a paper suggesting a systems approach to achieve a balance of transportation modes for the public. He considers various means of auto travel combined with methods of mass transit to suit individual needs. Beckett's paper, 'Innovations for Mass Transportation', will be presented Thursday morning, August 25th, in the Biltmore Hotel Ballroom.

HP Archive

This vintage Hewlett-Packard document was
preserved and distributed by

www.hparchive.com

Please visit us on the web!

On-line curator: John Miles, KE5FX

jmiles@pop.net

