



## Three New -hp- Audio Oscillators

**Y**EAR after year the simple, reliable -hp- R-C audio oscillator remains one of the work horses of the electronics laboratory. The Hewlett-Packard Company has always taken special pride in the R-C oscillator and has always striven to see that suitable R-C oscillators are provided for every purpose.

SEE ALSO:  
 "Balanced R-C  
 Oscillator," p. 4

The three oscillators shown in Fig. 1 are evidence of this program. These oscillators are redesigns which have been made of three popular -hp- instruments to incorporate in these instruments the latest electrical and mechanical features of the -hp- line of oscillators. Electrical features are described in detail below. Mechanically, the instruments are lighter in weight than their predecessors and are housed in new, smaller, more attractive cabinets. The frequency dials are all provided with high-ratio rim drives to permit convenient fine-position-

ing of the frequency dials. Rotary switches use bar type knobs for ease of switching.

### 1. HIGH-OUTPUT HIGH-QUALITY AUDIO TEST OSCILLATOR (20 CPS-20 KC)

The new Model 201C oscillator at the left in Fig. 1 is designed for testing higher-quality audio systems.\* The instrument operates over the range from 20 cps to 20 kc and provides a maximum of 3 watts into a 600-ohm load. Distortion in the output is less than 0.5% at levels below 1 watt and less than 1% at levels up to 3 watts.

The output circuit is designed so that the instrument can be operated either as a low source-impedance device or a 600-ohm source-impedance device. Fig. 2 shows the output circuit arrangement. The output transformer feeds through a precision bridged-T attenuator to the output terminals. To permit the instrument to be used as a low source-impedance de-

vice, the output attenuator is arranged with a zero-attenuation position in which the attenuator is switched completely out of the circuit. The output terminals then see the internal impedance of the amplifier. This impedance is low, in the order of 75 ohms below 5 kc, since a substantial amount of negative feedback is used in the amplifier. When zero output attenuation is used, the level of the

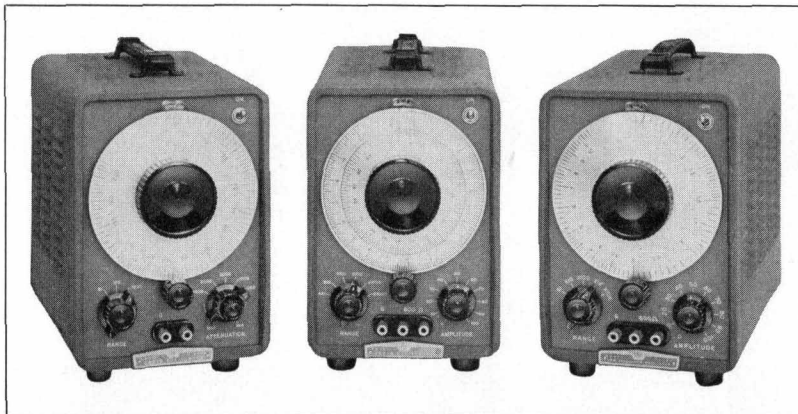

Fig. 1. New -hp- 201C, 200J and 202C Audio Oscillators take up only half the bench space of their predecessors. Two of these oscillators use the new type of R-C oscillator circuit described in article starting on pg. 4.

\*For highest quality systems consideration should also be given to the superlative -hp- 206A Audio Signal Generator.

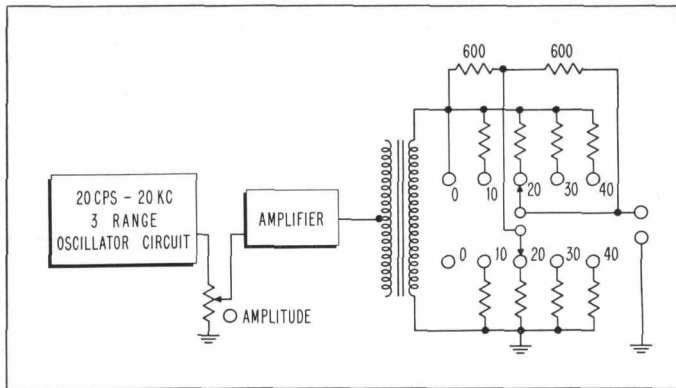

Fig. 2. Basic output circuit arrangement of Model 201C oscillator. Six-hundred ohm source impedance is obtained with output attenuator set for 20 db or more. Amplitude control permits continuous adjustment of output level.

output power is adjusted by an amplitude control located at the amplifier input (Fig. 2).

The output attenuator itself is provided with four 10 db steps (five attenuator switch positions). When 20 db or more of attenuation is inserted with the attenuator, the source impedance of the instrument is a close match to 600 ohms. Desired power levels which may lie between the 10 db attenuator steps can be selected with the amplitude control. This arrangement thus provides both a 600-ohm source and selection of any desired output from zero to 0.03 watt while keeping noise at a relatively fixed level below the output signal.

The amplitude and output attenuator controls, although located in different parts of the circuit, are made physically concentric in order to facilitate selection of the desired output level.

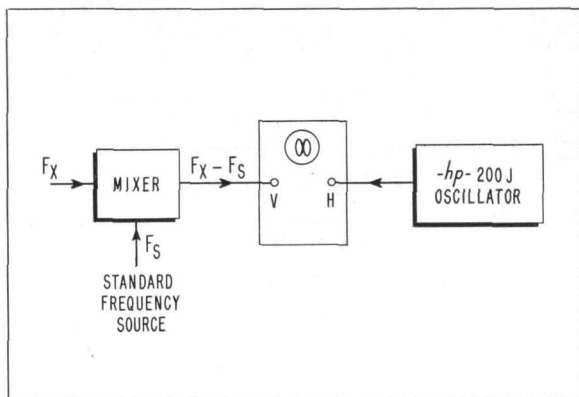

Fig. 3. Typical frequency measurement arrangement using -hp- 200J Audio Oscillator to measure difference between two higher frequencies.

with a large number of calibrated points on its frequency dial is required. Most of these applications deal with frequency measurement work. A typical situation, for example, is indicated in Fig. 3 where the difference frequency between two higher frequencies is to be measured by means of lissajous patterns on an oscilloscope. By connecting the 6 cps-6 kc spread-band oscillator shown at the center in Fig. 1 to the appropriate set of deflecting-plates on the oscilloscope, the difference frequency can be measured accurately within  $\pm 1\%$ . This 1% tolerance represents an insignificant error on the overall measurement in most instances, since it applies only to the difference frequency and this is usually a small percentage of the main frequency being measured.

The frequency dial of the spread-band oscillator is reproduced in Fig. 4. The high order of definition of the frequency calibrations on this dial is evident. To aid in obtaining this definition, the frequency spread of each range of the instrument has been made 3.3:1 instead of the 10:1 which is usual in -hp- oscillators.

As implied above, the calibrations on the frequency dial of the

The new Model 201C supersedes the former -hp- Model 201B which has been discontinued.

#### II. 6 CPS-6 KC SPREAD-BAND OSCILLATOR FOR INTERPOLATION WORK

There are many applications where an oscillator

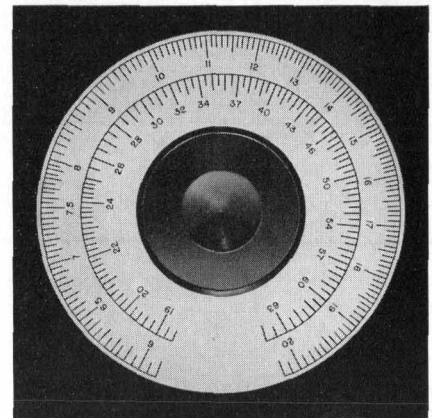

Fig. 4. Frequency dial of 200J 6 cps - 6 kc oscillator. Large number of calibrated dial points simplifies frequency measurement work.

Model 200J are accurate within  $\pm 1\%$ . A special feature of the instrument, however, is that it is arranged with standardizing controls in the form of screwdriver-operated internal adjustments which can be used to maintain the long-time accuracy of the frequency dial. If desired, these controls can also be used to obtain optimum accuracy over any desired portion of the dial that might be especially useful for a particular type of measurement.

The output circuit of the Model 200J is designed to provide 10 volts to an external load of 600 ohms. The internal impedance of the circuit is also 600 ohms so that as much as 20 volts is available open circuit. The output system is arranged in the same way as that of the -hp- 202C which is described later.

The new Model 200J supersedes the former -hp- Model 200I. The latter has been discontinued.

#### III. 1 CPS-100 KC LOW FREQUENCY OSCILLATOR

The instrument at the right in Fig. 1 is designed with a very wide frequency range—from 1 cps to 100 kc. This wide range enables the instrument to be used for a wide variety of purposes throughout the sub-audio, audio and ultrasonic ranges, but design emphasis has been placed on making the instrument especially suitable for low-frequency purposes.

The instrument is thus especially suitable for such purposes as a frequency source for vibration studies and for testing servo, medical and geological survey equipment.

To achieve a high order of performance at low frequencies, the instrument uses a special type of R-C oscillator circuit which is described in a separate article in this issue.

The instrument will provide a maximum output of 10 volts across a load of 600 ohms or 20 volts open circuit. The frequency output is stable within  $\pm 2\%$  under usual operating conditions. The stability tolerance includes warm-up drift, calibration error and reasonable aging of components. Distortion in the output is less than 0.5% above 10 cps and, because of the special design of the circuit, is not influenced by any load impedance from open circuit to short circuit.

The output transformers are balanced within 0.1% at the lower frequencies and the instrument is arranged so that it can be used as a balanced source if desired. The output power is controlled by an unbalanced bridged-T attenuator made up of variable controls. This attenuator is arranged, however, so that at full output the series arms short and the shunt arm opens, thus removing the attenuator from the circuit. Under this condition the output terminals see the internal impedance of the system which has been made equal to 600 ohms. The system can thus be used as a balanced 600-ohm source if desired. In addition, either of the output terminals can be grounded.

A special convenience of the instrument is that the circuit recovery time after switching ranges is less than 5 seconds even at the lowest frequencies that the instrument generates.

The *-hp-* Model 202C supersedes the former Model 202B which has been discontinued.

—Brunton Bauer

## SPECIFICATIONS

### MODEL 201C AUDIO OSCILLATOR

**FREQUENCY RANGE:** 20 cps to 20 kc in three ranges.

**RANGES:** X1 20 cps to 200 cps  
X10 200 cps to 2 kc  
X100 2 kc to 20 kc

**CALIBRATION ACCURACY:**  $\pm 1\%$ . Calibration controls provided for standardizing bands.

**FREQUENCY STABILITY:**  $\pm 2\%$  or 0.2 cps (whichever is greater) under normal temperature conditions and including initial warmup, aging of components, etc.

**FREQUENCY RESPONSE:**  $\pm 1$  db over entire frequency range. (Reference 1 kc.)

**OUTPUT:** 3 watts max. or 42.5 volts into 600 ohm load. One terminal at ground potential. 50 volts maximum no-load voltage.

**DISTORTION:** Less than 1/2%, 50 cps to 20 kc at 1 watt output. Less than 1%, 20 cps to 20 kc at 3 watts output.

**ATTENUATOR:** 0-40 db in 10 db steps—concentric amplitude control varies output continuously zero to maximum at any attenuator setting.

**INTERNAL IMPEDANCE:** Approx. 75 ohms below 5,000 cps at zero setting of attenuator. Approx. 600 ohms entire frequency range with output attenuator at 10 db or more.

**HUM VOLTAGE:** Less than 0.05% of rated or attenuated output. (Amplitude control at maximum.)

**POWER:** 115/230 volts  $\pm 10\%$ , 50/1,000 cps, approx. 75 watts.

**DIMENSIONS:** Cabinet Mount—7½" wide, 11½" high, 12½" deep. Rack Mount—19" wide, 7" high, 12" deep.

**WEIGHT:** Cabinet Mount—16 lbs.; shipping weight approx. 23 lbs. Rack Mount—18 lbs.; shipping weight approx. 35 lbs.

**PRICE:** *-hp-* Model 201C Audio Oscillator, Cabinet Mount, \$225.00. *-hp-* Model 201CR Audio Oscillator, Rack Mount, \$230.00.

### MODEL 200J AUDIO OSCILLATOR

**FREQUENCY RANGE:** 6 cps to 6,000 cps.

**DIAL CALIBRATION:** 2 bands, A: 6 to 20; B: 20 to 60.

**RANGE:** A x 1 6 to 20 cps  
B x 1 20 to 60 cps  
A x 10 60 to 200 cps  
B x 10 200 to 600 cps  
A x 100 600 to 2,000 cps  
B x 100 2,000 to 6,000 cps

**CALIBRATION ACCURACY:**  $\pm 1\%$ . Calibration controls provided for standardizing bands.

**FREQUENCY STABILITY:**  $\pm 2\%$  or 0.2 cps (whichever is greater) under normal temperature conditions and including initial warmup, aging of components, etc.

**FREQUENCY RESPONSE:**  $\pm 1$  db entire frequency range (reference 1 kc).

**OUTPUT:** 160 milliwatts into 600 ohm rated load, or 10 volts. 20 volts open circuit.

**OUTPUT BALANCE:** Better than 0.1%. Output is balanced to ground at maximum amplitude setting. (May be operated with one side grounded if desired.)

**INTERNAL IMPEDANCE:** 600 ohms.

**DISTORTION:** Less than 0.5% entire frequency range. Independent of load impedance.

**HUM VOLTAGE:** Less than 0.1% of rated output. Decreases as output is attenuated.

**POWER:** 115/230 volts,  $\pm 10\%$ , 50/1,000 cps, approx. 110 watts.

**DIMENSIONS:** Cabinet Mount—7½" wide, 11½" high, 14¼" deep. Rack Mount—19" wide, 7" high, 12½" deep.

**WEIGHT:** Cabinet Mount—23 lbs.; shipping weight approx. 29 lbs. Rack Mount—25 lbs.; shipping weight approx. 42 lbs.

**PRICE:** *-hp-* Model 200J Audio Oscillator, Cabinet Mount, 6 cps-6 kc, \$275.00. *-hp-* Model 200JR Audio Oscillator, Rack Mount, 6 cps-6 kc, \$280.00.

### MODEL 202C LOW FREQUENCY OSCILLATOR

**FREQUENCY RANGE:** 1 cps to 100 kc in five ranges.

**RANGES:** X1 1- 10 cps  
X10 10- 100 cps  
X100 100-1000 cps  
X1k 1- 10 kc  
X10k 10- 100 kc

**ACCURACY:**  $\pm 2\%$  under normal ambient temperature conditions, including calibration error, warmup, changes due to aging of components, tubes, etc.

**FREQUENCY RESPONSE:**  $\pm 1$  db entire frequency range (reference 1 kc).

**OUTPUT:** 160 milliwatts into 600 ohm rated load, or 10 volts. 20 volts open circuit.

**OUTPUT BALANCE:** Better than 0.1% at lower frequencies and approximately 1% at 100 kc. Output is balanced to ground at maximum amplitude setting. (May be operated with one side grounded if desired.)

**INTERNAL IMPEDANCE:** 600 ohms.

**DISTORTION:** Less than 0.5% above 10 cps. Independent of load impedance. Less than 3% at 1 cps.

**HUM VOLTAGE:** Less than 0.1% of rated output. Decreases as output is attenuated.

**RECOVERY TIME:** Less than 5 seconds at 1 cps.

**POWER SUPPLY:** 115/230 volts,  $\pm 10\%$ , 50/1,000 cps, approximately 110 watts.

**DIMENSIONS:** Cabinet Mount—7½" wide, 11½" high, 13½" deep. Rack Mount—19" wide, 7" high, 14¼" deep.

**WEIGHT:** Cabinet Mount—27 lbs.; shipping weight approx. 34 lbs. Rack Mount—29 lbs.; shipping weight approx. 44 lbs.

**PRICE:** *-hp-* Model 202C Low Frequency Oscillator, Cabinet Mount, \$300.00. *-hp-* Model 202CR Low Frequency Oscillator, Rack Mount, \$305.00.

All prices f.o.b. Palo Alto, California. Data subject to change without notice.



## THE *-hp-* BALANCED R-C OSCILLATOR CIRCUIT

THE *-hp-* Model 200CD 5 cps-600 kc audio oscillator which was introduced several years ago used an interesting new type of R-C oscillator circuit which has come to be known as the *-hp-* balanced R-C audio oscillator circuit. This same basic circuit is used in the new *-hp-* Models 200J and 202C described elsewhere in this issue.

The balanced R-C oscillator offers a number of advantages, especially for low-frequency operation. These can be summarized as follows:

- The circuit is balanced and a balanced output can be derived directly from it.
- At low frequencies the ballast element introduces less second harmonic distortion than in the conventional single-ended circuit.
- The effect of insulation leakage resistance is decreased in certain circuit locations.
- The oscillator has essentially a zero-impedance output and may therefore be loaded directly

(without a buffer amplifier) with little or no reaction.

### CIRCUIT DESCRIPTION

Consider first the conventional single-ended R-C oscillator circuit shown in basic form in Fig. 1. In this circuit the frequency-determining network in the positive feedback path has voltage-dividing and phase characteristics like those shown in Fig. 1(b). When the network is used with an amplifier with  $360^\circ$  phase shift, the voltage on the grid of the first amplifier tube will be reinforced by the output of the network so that oscillation will occur if the gain of the amplifier is sufficient. The phase characteristic of the network restricts the operating frequency to  $f_0$ , which is also the frequency at which maximum output is obtained from the network.

A second important part of the single-ended oscillator is the network  $R_F$  and  $R_L$ . These resistances form a negative feedback path for the circuit. The resistance  $R_L$  is a small tungsten-filament lamp whose resistance increases with level. This lamp varies the amount of feedback in accordance with the amplifier output level so as to keep constant the amplitude of oscillation at a level which maintains circuit operation on a linear portion of the amplifier transfer characteristic. Since linear operation is always maintained, the oscillator inherently has low distortion.

### BALANCED OSCILLATOR

The basic arrangement of the new balanced oscillator circuit is shown in Fig. 2. This circuit is different in several respects

from the circuit shown in Fig. 1. First, the voltage division in the frequency-determining network is now  $\frac{1}{2}$  instead of  $\frac{1}{3}$ . Second, the circuit is floating instead of single-ended. Third, the outputs of the frequency-determining and amplitude control networks are operated into a balanced amplifier instead of a single-ended amplifier. Fourth, no d-c current is passed through the lamps. (Two lamps are used instead of one merely to achieve the proper voltage division.)

Assuming that the circuit is oscillating, its operation can be described as follows. The amplitude of oscillation will be such that the total resistance  $R_L$  of the lamps will be slightly less than the resistance of  $R_F$ . This means that the grid of  $V_1$  will be excited by a small fraction of the output of amplifier B which is out of phase with the output of amplifier A. The output of amplifier A will be slightly larger than the output of amplifier B so that the grid of  $V_2$  will be excited by a small fraction of the output of amplifier A. Since the outputs of amplifiers A and B are out of phase, the grids of  $V_1$  and  $V_2$  are excited with out-of-phase voltages, as they must be to sustain oscillations. The amplifiers themselves introduce  $180^\circ$  phase shift so that the output of each amplifier is of proper phase

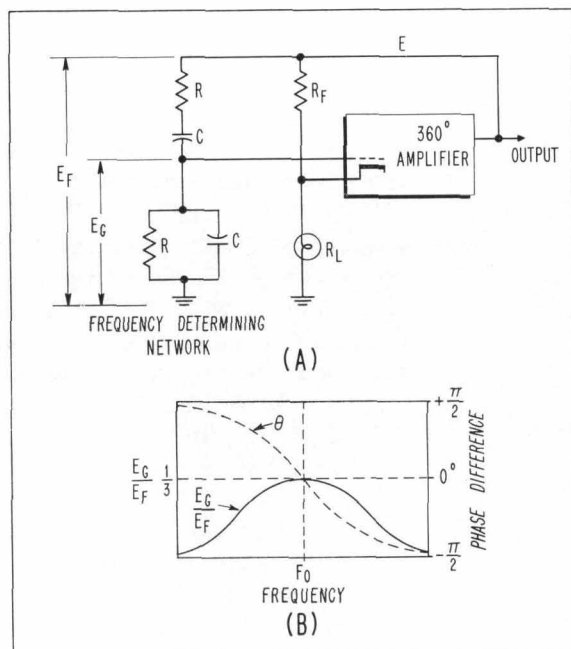
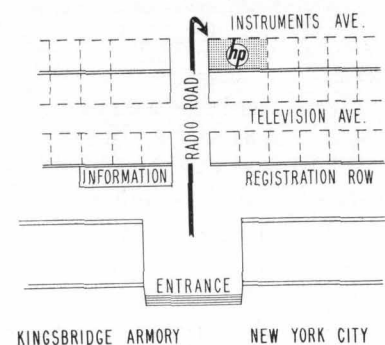

Fig. 1. (a) Basic arrangement of *-hp-* single-ended R-C oscillator circuit. (b) Voltage-division and phase characteristics of frequency-determining network.

SEE THE NEW OSCILLOSCOPES *-hp-* WILL INTRODUCE AT THE IRE SHOW, BOOTHS 248, 250



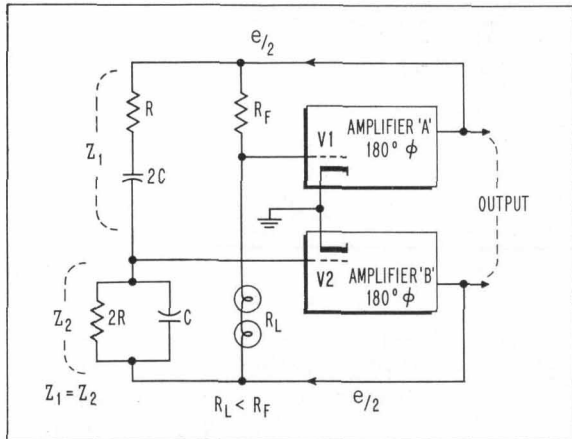

Fig. 2. Basic arrangement of *hp*-balanced R-C oscillator.

to reinforce the input of the opposite amplifier.

Should the amplitude of oscillation tend to increase or decrease, the resistance of the lamps will tend to increase or decrease in such a way as to decrease or increase the drive on  $V_1$ . This action will thus decrease or increase the drive on  $V_2$ . In this way the amplitude of oscillation will be maintained constant.

#### BALLAST LAMP PERFORMANCE

One of the factors that determines the lowest frequency at which an R-C oscillator can satisfactorily be operated is the thermal time constant of the lamp. As the oscillator is tuned to lower and lower frequencies, a point is eventually reached where the lamp resistance tends to follow the individual variations of the a-c cycle. The frequency at which this effect occurs depends on a number of factors but is typically in the vicinity of 1-10 cps.

The effect of a varying lamp resistance is to introduce distortion in the generated signal when the variation is small and to cause both distortion and unstable operation as the variations become larger.

It is interesting to note that a given lamp will produce no second harmonic distortion and can therefore be operated to significantly lower frequencies if no d-c is passed through the lamp. Consider first the case where d-c is passed through the lamp. The total current through the lamp then consists of some a-c cur-

rent from the output combined with the d-c and a-c components of the first amplifier tube's space current. The two a-c components have the same frequency and phase and can be combined. The current through the lamp is thus

$$i_{lamp} = I_{d-c} + I_1 \sin \omega t.$$

The resistance of the lamp, however, is a function of the power in the lamp:

$$R_{lamp} = f(i_{lamp})^2 = f(I_{d-c}^2 + 2I_{d-c}I_1 \sin \omega t + I_1^2 \sin^2 \omega t).$$

Substitution of the identity

$$\sin^2 \omega t = \frac{1 - \cos 2\omega t}{2}$$

gives for the above

$$R_{lamp} = f(I_{d-c}^2 + \frac{I_1^2}{2} + 2I_{d-c}I_1 \sin \omega t - \frac{I_1^2}{2} \cos 2\omega t). \quad (1)$$

The term of interest here is the term  $2I_{d-c}I_1 \sin \omega t$ . This term shows that, when the frequency of oscillation becomes comparable with the thermal time constant of the lamp, the resistance of the lamp begins to vary at the fundamental frequency. When this "following" action becomes sufficiently pronounced, the operation of the circuit is impaired and eventually the circuit does not operate at all. Further, the fundamental frequency component of the current will intermodulate with this resistance variation to produce second harmonic (as well as higher order harmonics) in the voltage across the lamp.

#### BALLAST LAMP IN BALANCED CIRCUIT

Consider now the balanced oscillator case where no d-c is passed through the lamp. Since  $I_{d-c}$  in equation (1) is now zero, equation (1) becomes

$$R_{lamp} = f\left(\frac{I_1^2}{2} - \frac{I_1^2 \cos 2\omega t}{2}\right) \quad (2)$$

Expression (2) shows that when no d-c is in the lamp the lowest frequency resistance variations are at twice the fundamental frequency. In other words, a lamp of given ther-

mal time constant with no d-c can be operated to half the frequency of the same lamp with a significant amount of d-c. Further, the lamp introduces no second harmonic distortion, since there is no fundamental frequency resistance variation for the fundamental component of current to intermodulate with.

In the design of *hp*-R-C oscillators the effect of d-c on the lamp's resistance has always been recognized and low values of d-c have always been used where low-frequency performance was involved. The balanced R-C oscillator, however, affords a circuit in which the d-c can be eliminated completely.

#### CAPACITOR INSULATION

Examination of the frequency-determining network in both the single-ended and balanced oscillators (Figs. 1 and 2) will show that in both cases the rotor of the tuning capacitor must be insulated from ground. Further, at low frequencies the impedances in the frequency-determining network become very large so that the capacitor rotor is at a very high impedance to ground. Since the insulation resistance must be very high compared with any frequency-determining resistance which it shunts, the insulation must meet stringent requirements.

While the above consideration applies to both the single-ended and balanced oscillator, the requirements in the balanced oscillator are of the order of 30 times less severe. This occurs because of the difference in signal level between the tuning capacitor rotor and ground in the two circuits. In the single-ended oscillator the voltage from the rotor to ground is  $e/3$  (Fig. 1). In the balanced oscillator, however, the rotor is nearly at ground. The voltage to ground is only that amount needed to provide drive for the grid of the amplifier and this amounts to only  $e/2\mu$ , where  $\mu$  is the amplifier gain. Since  $e$ , the output voltage of the circuit, is approximately the same in the two cases, the voltage to ground

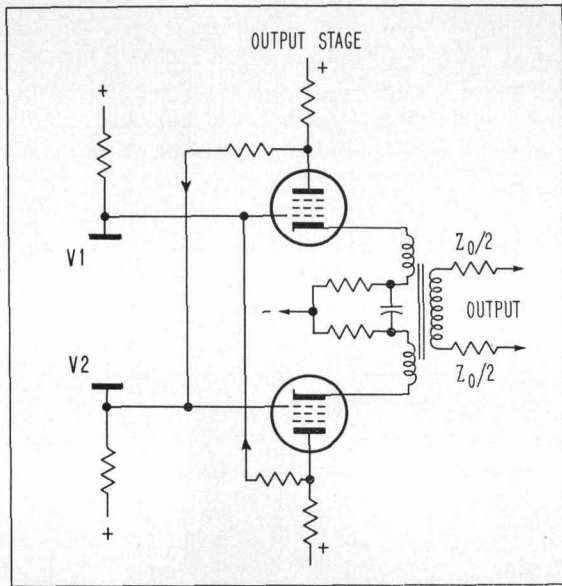

Fig. 3. Basic arrangement in balanced output stage for obtaining local positive feedback.

in the balanced case is reduced by the factor  $3/2\mu$ .  $\mu$  has a value in the order of 50 so that the signal voltage across the rotor insulation resistance is only about 3% of that in the single-ended case. The leakage current for a given rotor to ground insulation resistance will thus be only 3% as large as in the unbalanced case and the resulting disturbances will be proportionately reduced.

#### ZERO OUTPUT Z AMPLIFIER

The output stage of the oscillator is designed to have zero output impedance, a fact which offers several advantages in use. For one thing, the

oscillator can be operated into any finite load impedance with little reaction on the oscillator. It is thus unnecessary to use a separate output amplifier merely for isolation purposes. For another thing, the output circuit can be operated into an output transformer of simplified design.

Bode shows that the output impedance of an amplifier is

$$Z = Z_o \frac{(1 - \mu\beta_{sc})}{(1 - \mu\beta_{oc})}$$

where  $\mu\beta_{sc}$  and  $\mu\beta_{oc}$

are the loop gains which exist when the amplifier output is short-circuited and open-circuited, respectively, and  $Z_o$  is the output impedance in the absence of feedback.

Examination of the above expression shows that if the  $\mu\beta_{sc}$  term in the numerator is made equal to unity, the output impedance of the amplifier becomes zero. This will be true as long as the denominator has a finite value. To make  $\mu\beta_{sc}$  equal to unity, it suffices to design the output stage of the amplifier so that its local feedback is  $+1$  with the output terminals (cathodes) shorted.

Fig. 3 shows how the necessary feedback is supplied in the output stage of the balanced amplifier associated with the frequency-determining and amplitude control circuitry described previously. In this circuit positive feedback of the proper magnitude is obtained from each plate by cross-connecting to the opposite control grids. The term  $\mu\beta_{oc}$  for the output stage is automatically zero, since when the output is open-cir-

cued no local feedback occurs. Suitable resistances are inserted in series with the output circuit so that the cathodes will never be short-circuited in practice. This inserted resistance together with a twofold excess current capacity in the output tubes permits the circuit to be shorted if desired without affecting the oscillator or producing distortion in the resulting output current.

To minimize the effect that the interstage capacities would have on wide-band feedback, these capacities are formed into a frequency-insensitive voltage divider in the positive feedback circuit of the output stage. How this divider is formed is indicated in Fig. 4. The positive feedback lead from one tube is connected to the screen grid of the opposite tube and to the frequency-insensitive voltage divider. The control grid is connected to the intermediate point on the divider.

The capacitive arms of the voltage divider consist of the control grid-screen grid capacity of the output tube and the interstage capacity to ground. The resistive arms consist of a special resistance inserted between the control and screen grids and the interstage resistance to ground. By this means positive feedback is applied to both the screen and control grids of the output tubes while constructive use is made of parasitic capacities. At very high frequencies where cathode to ground capacity might effectively short the output cathode and allow the stage to oscillate or be only marginally stable, the positive feedback is reduced by plate to ground capacities  $C_p$ .

The complete circuit also includes other simple circuit elements which flatten the frequency response of the first stage. One of these is the peaking inductance shown connected in the voltage divider in Fig. 4. Since the ends of this inductance are at equipotential points as far as the feedback voltage is concerned, the inductance has no effect on the dividing action.

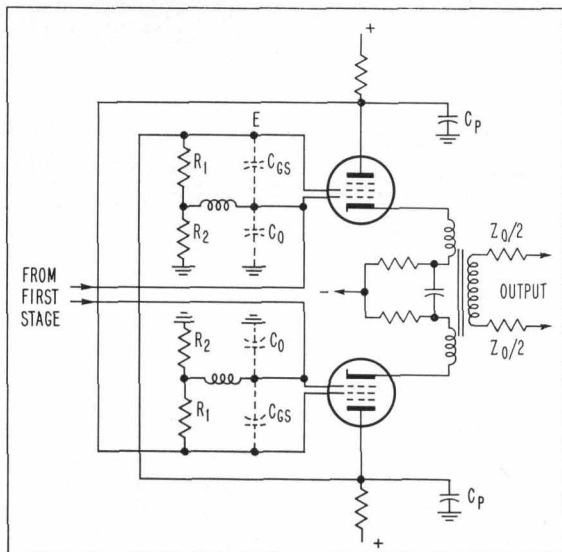

Fig. 4. Diagram showing how stray capacities are formed into frequency-insensitive voltage divider.