

HP

SEPTEMBER 1996

# Professional

**NEW COLUMN:**  
**The Internet  
Digest**  
PAGE 56

# CORPORATE communications

Is e-mail a synch or swim solution?

Building Client-Server Computing  
On The HP 3000, Part 2

PAGE 39

EDI: Ready And Waiting For The Internet

PAGE 33





# HP 9000 & HP 3000 DLT Tape Solutions

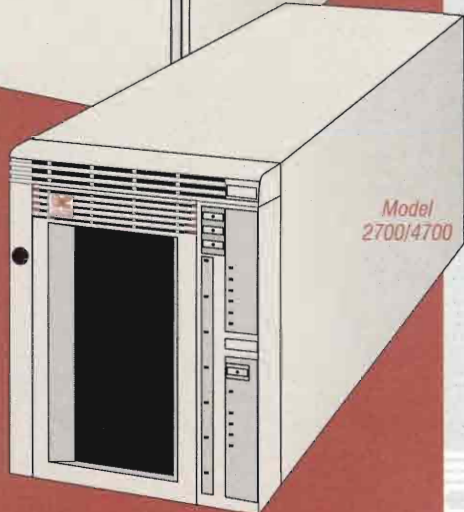
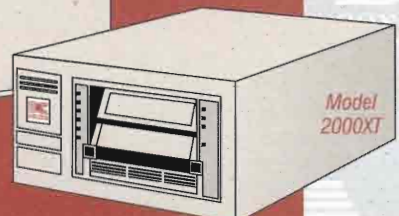
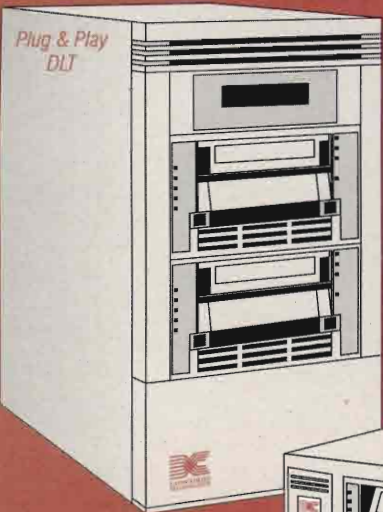

## Capacity, Performance & Reliability

These are all advantages inherent to Digital Linear Tape (DLT) technology. Your data-intensive applications require an "industrial strength" solution. DLT Tape offers exceptional durability and data integrity along with the ability to grow easily with your emerging needs.

Concorde Technologies, Inc. provides a full line of DLT tape solutions.

### DLT Drives

- 20-40 GB Capacity/Tape\*
- 1040 GB Library Capacity\*
- 1.5-3.0 MB/Sec. Drive Transfer Rate\*
- 80,000 Drive MTBF
- 10,000 Hour Head Life

### DLT Libraries

- 1-9 Drives/Library
- 3-of-9 Bar Code Reader
- Up to 264 DLT Cartridges
- Capacities to 10 TB/Library\*
- Throughput to 1.3 TB/Hour\*

### DLT Software

- Backup/Restore Software
- "Hot" Database Backup
- Bar Code Support
- HSM Software
- OmniBack II Support
- Heterogeneous Network Support

### Technical Services

- Training
- Installation
- Consulting
- Requirements Analysis

Concorde specializes in high-performance network backup/restore solutions for HP 9000 Servers and Workstations. Backed by HP experience and a commitment to support, Concorde is an established leader among Hewlett-Packard Channel Partners.

To discuss your specific application or for a free backup/restore solutions catalog, contact a Concorde Sales Engineer.



800-359-0282



### Concorde Technologies, Inc.

9770 Carroll Center Road, Suite F, San Diego, CA 92126-6504 USA  
 (619) 536-5500, (800) 359-0282, Fax: (619) 566-4396  
 E-mail: [info@concordetech.com](mailto:info@concordetech.com)  
<http://www.concordetech.com>

\* Assumes 2:1 compression

CIRCLE 232 ON READER CARD



# Choices

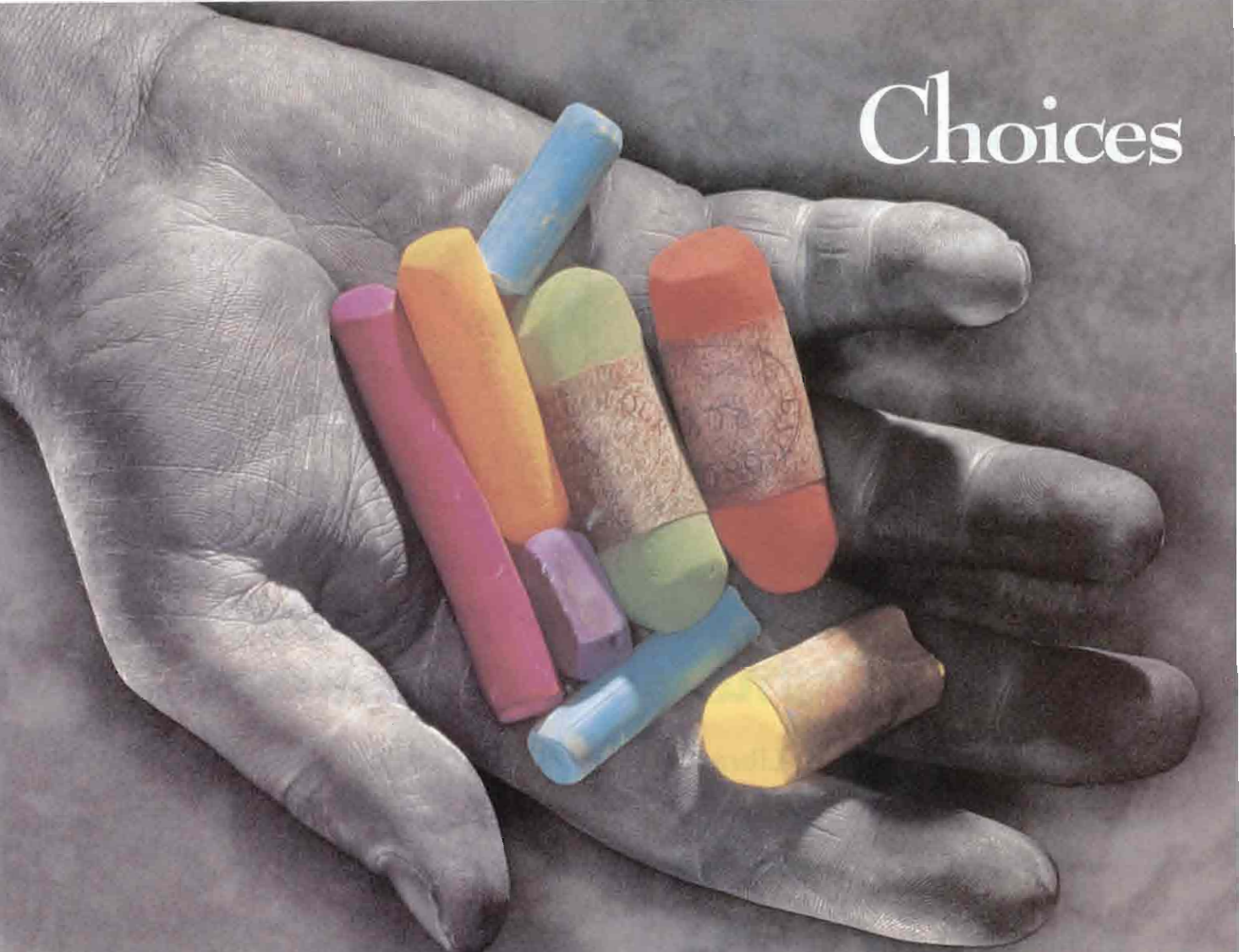

## Create your own vision of storage management with AMASS software

AMASS software gives you the freedom to choose the optical jukebox or automated tape library, and media, that best meets your specific storage requirements.

LIBRARIES		MEDIA
EMASS	Kodak	5.25" optical
ATL Odetics	MountainGate	12" & 14" WORM
Breece Hill	Panasonic	CD ROM
Cygnnet	Philips LMS	DLT
DISC	Plasmon	DTF
Hewlett Packard	Sony	VHS
IBM	StorageTek	3590
	others	others

And the best part is AMASS is so easy to use. The automated library is presented as a single UNIX file system under one mount point compatible with NFS. Your applications simply read and

write files to the library as if it were a large magnetic disk. An on-line index tracks files, on media *in and out* of the library, for fast file system operations such as ls, cd, find... Optional multi-tier file migration and automatic file replication is also available.

EMASS, Inc. also offers the only automated true mixed-media libraries, in capacities from GBytes to hundreds of TBytes.

### *So why not draw on our creativity?*

Contact EMASS for a free copy of the AMASS Overview book or for a 30 day free software trial. Reseller inquiries welcomed.



1-800-653-6277

Europe +44-1344 382 119

[storage@emass.com](mailto:storage@emass.com)

<http://www.emass.com>

**EMASS**  
Storage Management Software

A Raytheon E-Systems Company

CIRCLE 296 ON READER CARD

# Why Gamble?

## when IEM has risk-free solutions for a lights-out environment

### Alexandria Network Backup Librarian

Alexandria supervises every facet of your heterogeneous UNIX network backup:

- Organizes and automates your system backups
- Manages all of your backup media
- Can back up your entire network, even if it consists of several UNIX platforms
- Performs cold database backups of Oracle, Sybase and Informix databases
- Performs hot backups of Oracle databases with an additional module

### Vantage Console Access Technology

- Consolidates control of a variety of systems and other resources (such as printers and terminal emulators) over a LAN or WAN to a single HP 9000/700 workstation
- Monitors console traffic in real time, responding to pre-defined events with visual or auditory alerts, or through third-party or user-defined applications such as email or paging software
- Allows management of resources to be transferred between different Vantage workstations on the network

## Tape Libraries

### DLT libraries

- 3 MB/sec drive transfer rate
- up to 9 DLT4000 drives for 97.2 GB/hour library throughput
- 28 to 264 cartridges for 10.56 TB library capacity
- one-year on-site service included

### 8mm Mammoth libraries

- 6 MB/sec drive transfer rate
- up to 4 Mammoth drives for 86.4 GB/hour library throughput
- up to 80 cartridges for 3200 GB library capacity

### 4mm & 8mm carousel libraries

- 1 MB/sec drive transfer rate
- up to 4 DDS-2 or 8505XL drives for 14.4 GB/hour library throughput
- library capacity up to 480 GB (4mm) or 560 GB (8mm)
- touch screen interface

Transfer rates and capacities given for all libraries are with a 2:1 compression ratio.

### *IEM: Providing Solutions for a Lights-out Environment*

In the U.S. and Canada:  
IEM, Inc., P.O. Box 1889  
Fort Collins, CO 80522 USA  
Phone: (970) 221-3005  
(800) 321-4671  
Fax: (970) 221-1909

In the United Kingdom:  
IEM, Inc., Unit 6, Salisbury House,  
Wheatfield Way, Hinckley Fields,  
Hinckley, Leicester LE10 1YG  
Phone: +44 (0)1455 239000  
Fax: +44 (0)1455 239668

All others:  
IEM International Sales  
1629 Blue Spruce Drive  
Fort Collins, CO 80524 USA  
Phone: +[1] 970-221-3005  
Fax: +[1] 970-221-1909



© 1996 Anis Inc. CI.596

email: [info@iem.com](mailto:info@iem.com)

CIRCLE 122 ON READER CARD

<http://www.iem.com>



# Contents

September 1996

Vol. 10, No. 9

## It's In The Mail

By Barry Slawter

*As the World Wide Web captures the imagination of the public, corporations today often act overanxiously when examining the Web's incredible "potential." Still, everyone needs e-mail. Granted, in the world of office communication, e-mail may not be the hippest topic these days, but not having it in your company can be disastrous. Here's a look at the part e-mail plays in the new realm of interactive messaging.*

23

## EDI & The Internet...Right Now

By Pushpendra Mohta

*Despite 15 years of government and industry advocacy, EDI hasn't grown as rapidly as most expected due to the high cost, as well as the dedicated, proprietary value-added networks required. However, companies are finding that the Internet provides a flexible vehicle for electronic collaboration, information distribution and business-to-business interactions.*

33

## A White Paper: Building Client-Server Applications On The HP 3000, Part 2

By Rohan Hall

*Last month, Part 1 of Building Client-Server Applications On The HP 3000 introduced the "notion of client-server on the HP 3000" by explaining the elements of the server as well as defining the terms commonly used in client-server computing. This month, Part 2 looks at the client, including hardware, programming software and networking requirements.*

39

## COLUMNS

**Industry Watch** By George A. Thompson

HP reports a 26 percent decline in net earnings; HP releases the first HP 9000s based on the 64-bit PA-8000 CPU; Ira Goldstein returns to HP as Internet technology officer and chief technology officer for HP's CSO; HP introduces the Enterprise NetServer Operation (ENO); Compaq announces a new Workstation Division; HP's next generation OS time table; and the HP 3000: Alive and well in HP's world. . . . . 8

**UNIX At Large: Waxing Eclectic** By Fred Mallett

A little bit of this, and a little bit of that. Answers to your burning questions concerning search paths, troubles with LaserROM, man-k problems, and CDE and logins . . . . . 44

**Inner Networking: The Webification Of OpenView** By Jill Huntington-Lee

HP OpenView integrates with Netscape to ease the burden of network management through the use of the Web . . . . . 46

**PREMIER: Internet Digest: Spam, Spam, Wonderful Spam. Not!** By Mark McFadden

You can get Eggs, Spam, and Spam, or Eggs Spam, Spam, Spam, Spam, hold the eggs or Spam, Spam, Spam, Spam.... Enough with the Spam already! . . . . . 56



### PRODUCT WATCH:

Unison Software's RoadRunner 3.0 . .12

Andataco's Web Storage Manager . . 14

### STRATEGIC DIRECTIONS:

EMC? . . . . . 16

### INSITES:

Database Excelleration Systems Solves I/O Contention Problems For BEA Associates And Camelot Music . . . . . 18

Editorial . . . . . 7

Letters To The Editor . . . . . 11

Reader Information/  
Advertiser Index . . . . . 41

New Products . . . . . 48

Product Showcase . . . . . 52



Cover Illustration by Jae Shim

**R**eliable,  
loyal,  
and he'll  
always  
be there  
for you  
long after  
you take  
him home

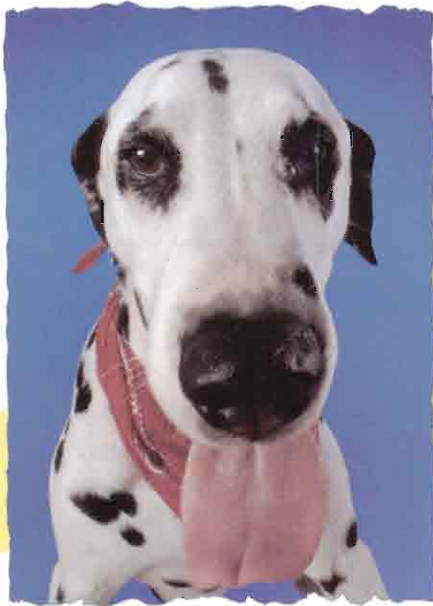

Much like  
**Workstation  
Solutions**

**QUICK RESTORE V2**

**F**  
**E**  
**A**  
**T**  
**U**  
**R**  
**E**  
**S**

- Control backup & recovery on a heterogeneous network without using NFS
- On-line indexing, automatic volume location & direct-to-block positioning
- Full support for popular robots and bar code readers
- Easy-to-use and highly reliable or your money back!



workstation solutions, inc. • one overlook drive • amherst nh 03031 • 603.880.0080 fax 603.880.0696  
e-mail info@worksta.com • http://www.worksta.com

All company and product names are trademarks or registered trademarks of their respective owners.

CIRCLE 253 ON READER CARD

**HP PROFESSIONAL EDITORIAL ADVISORY BOARD**

**Nigel Ball**  
Marketing Director For HP's General Systems Division

**Robert Bruen**  
Computing and Networking Manager at the MIT Lab for Nuclear Science

**Frank Humphries**  
Director of Marketing at HP Asia Pacific Ltd.

**Thomas Kucharvy**  
President of Summit Strategies

**John R. Logan**  
Vice President of Aberdeen Group Inc.

**Michael J. Meinz**  
Principal Technical Consultant at General Mills Inc.

**Glenn Osaka**  
General Manager of HP's Commercial Systems Business Unit

**Harry Sterling**  
General Manager for HP's Commercial Systems Division

**Bard F. White**  
CIO and Worldwide Director of MIS for Spalding Sports Worldwide

UNIX is a registered trademark of AT&T in the U.S.A. and in other countries. MS-DOS is a trademark of Microsoft Corp. Macintosh is a trademark of Apple Computer Inc. X Window System is a trademark of MIT. Windows is a registered trademark of Microsoft Corp. Windows NT is a registered trademark of Microsoft Corp. NetWare is a registered trademark of Novell Inc.

See us at UNIX EXPO in the HP Channel Partner booth #1402

**HP Professional**

**EDITOR-IN-CHIEF** Charlie Simpson  
simpsoncm@cardinal.com  
**SENIOR EDITOR** George A. Thompson  
thompsonga@cardinal.com  
**ASSOCIATE EDITOR** Deborah Schwartz  
schwartzdr@cardinal.com  
**ASSOCIATE EDITOR** Matt Hengey  
hengeymo@cardinal.com

**INTERNATIONAL EDITIONS EDITOR** Karine Simpson

**C O L U M N I S T S**

**INTERNET** Mark McFadden  
**NETWORK MANAGEMENT** Jill Huntington Lee  
**UNIX** Fred Mallett

**CONTRIBUTING AUTHORS** Sam Dickey, Rohan Hall, Scott R. Humphrey, Pushpendra Mohta, Marty Poniatowski, Barry Slawter, Jon Toigo

**D E S I G N & P R O D U C T I O N**

**EXECUTIVE DESIGN DIRECTOR** Leslie A. Caruso  
**ART DIRECTOR** Al Feuerstein  
**ASSOCIATE ART DIRECTOR** Kimberly Crean

**PRODUCTION MANAGER** Carla Loughlin  
**CARD DECK PRODUCTION MANAGER AND**  
**CARDINAL ON-LINE PRODUCTION MANAGER** Linda Hall

**C I R C U L A T I O N**

**CIRCULATION DIRECTOR** Carrie Eisenhandler  
**DIRECTOR OF FULFILLMENT** Margie Pitrone

**M A R K E T I N G**

**PROMOTIONS DIRECTOR** Timothy M. Kraft  
**MARKETING MANAGER** Veronica L. Sutsko  
**SENIOR GRAPHIC DESIGNER** Christine Piatkowski  
**GRAPHIC DESIGNERS** Mark Broomell, Candace Kent, Patty Wall

**PUBLISHER** Leslie Ringe

**CARDINAL BUSINESS MEDIA, INC.**

**PRESIDENT AND CHIEF EXECUTIVE OFFICER**  
Robert N. Boucher

**CHIEF FINANCIAL OFFICER**  
Thomas C. Breslin

**VICE PRESIDENT, PUBLISHING**  
R. Patricia Heron

**VICE PRESIDENT, HUMAN RESOURCES**  
Dorothy J. Flynn

**VICE PRESIDENT, SPORTS & MUSIC DIVISION**  
Thomas J. Morgan

**VICE PRESIDENT, RETAIL DIVISION**  
Mariamne Howatson

For more information on how to contact your sales representative, see page 41. For address changes and other subscription information, please call (847) 291-5212 or FAX (847) 564-9002. In the U.S., missed issues must be claimed within 45 days of publication date; outside the U.S., missed issues must be claimed within 90 days. Editorial, advertising sales and executive offices at 1300 Virginia Dr., Ste. 400, Fort Washington, PA 19034 • (215) 643-8000, Corporate FAX (215) 643-8099.

HP PROFESSIONAL ISSN 0896-145X is published monthly by Cardinal Business Media Inc., 1300 Virginia Dr. Ste. 400, Fort Washington, PA 19034. Subscriptions are complimentary for qualified U.S. and Canadian sites. For reprints, contact Reprint Management Services, 505 E. Airport Rd., Lancaster, PA 17601; (717) 560-2001, FAX (717) 560-2065. Periodicals postage paid at Fort Washington, PA 19034, and additional mailing offices. **US POSTMASTER:** Send all correspondence and address changes to HP PROFESSIONAL, P.O. Box 3053, Northbrook, IL 60065. **COPYRIGHT** © 1996 by Cardinal Business Media Inc. **CANADIAN POSTMASTER:** Send all correspondence and address changes to Cardinal Business Media, C/O N.I., P.O. Box 44, RPO Rockwood Mall, Mississauga, ON L4Z 9Z9. All rights reserved. No part of this publication may be reproduced in any form without written permission from the publisher. All submitted manuscripts, photographs and/or artwork are sent to Cardinal Business Media, Inc. at the sole risk of the sender. Neither Cardinal Business Media, Inc. nor HP PROFESSIONAL magazine is responsible for any loss or damage. HP PROFESSIONAL is an independent journal not affiliated with Hewlett-Packard Company. HP and Hewlett-Packard are registered trademarks and HP PROFESSIONAL is a trademark of Hewlett-Packard Company. Third class enclosure in this version of HP Professional.

Canada Post International Publication Mail Canadian Distribution Sales Agreement #IPM0264431



Printed in U.S.A.



WITH A BLINK OF AN EYE YOUR COMPANY COULD LOSE \$1,000,000



WITH THE BLINK OF A LIGHT YOU COULD SAVE YOUR COMPANY \$1,000,000

The lifesaving difference could be electronic. Then again, it could be audible, signaled by an e-mail notification, prompted via a Netscape™ GUI, flashed to your alpha-numeric pager . . . or all of the above. These proactive measures alert of device, power supply and fan failure, increases in temperature and hard & soft errors – the

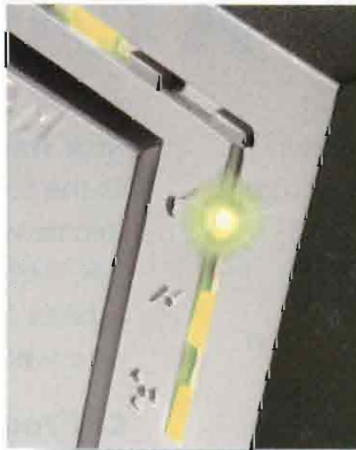

most common sources of data loss and unplanned downtime. With **proactive storage management** you're advised of potential problems before you're forced into a crisis management mode.



ANDATACO's ESP, **Enterprise Storage Packaging**™ is an intelligent data storage system comprised of highly-accessible **disk, tape** and RAID systems that are scalar from desktop to data center. Integrate ESP with Exabyte 8mm technology to engineer the ultimate in data accessibility and user productivity. Don't even blink.



**Protect your data** with a call to your ANDATACO account manager at 800-334-9191 or log in now to [www.andataco.com](http://www.andataco.com)

to inquire about winning an ESP Storage System.

**CIRCLE 386 ON READER CARD**



10140 Mesa Rim Road San Diego, Calif. 92121 619-453-9191 fax: 619-453-9294 email: [ESP-ebxhp@andataco.com](mailto:ESP-ebxhp@andataco.com) URL: <http://www.andataco.com>

*Enterprise Storage Packaging is a trademark of ANDATACO. All products are registered trademarks or trademarks of their respective companies.*



HP Series	MB	1	2	4	8	12	16	32	64	128	256
HP-200/310/320		●	●	●	●						
HP-319				●	●						
HP-330/350/370						●					
HP-332				●							
HP-340				●							
HP-345/375/380				●	●		●	●			
HP-360				●	●	●	●				
HP-362		●	●	●							
HP-382			●	●		●					
HP-400/425/433				●	●		●	●			
HP-425E				●	●		●	●			
HP-700RX		●	●	●	●						
HP-705/710					●		●	●			
HP-715/725				●	●		●	●	●		
HP-720/730/735					●		●	●	●	●	
HP-742/745/747				●	●		●	●	●	●	
HP-750/755					●		●	●	●	●	●
HP-8X7/9X7							●	●	●	●	●
HP-FXX/GXX/HXX/IXX							●	●	●	●	●

# PICK A CARD.

**Any card.** The memory you need is in stock, tested and ready to go. Order today. Upgrade your system tomorrow.

You'll get the quality and service you expect from the leader in HP workstation enhancements. We specialize in HP, it's the platform we know best.

Newport Digital TURBO cards and memory products are guaranteed to meet or beat HP quality standards. Every card we ship has been rigorously tested in a fully functional workstation, just like yours.

**Risk free.** Our total quality program gives us the confidence to offer an unconditional lifetime warranty. If one of our products fails, we'll ship a replacement by overnight express. We'll do anything we can to keep your workstation working.

**Call Today.** Speak with an expert on Hewlett-Packard computers. We'll make sure you get the cards you need.

Evaluate any of our memory products for 30 days. If you're not completely satisfied, return it without obligation.

**NEWPORT DIGITAL**  
**1-800-383-3642**

CIRCLE 246 ON READER CARD



# Of Dogs And Ponies

Last month during HP World in Anaheim, Calif., *HP Professional* was privileged to have several exclusive one-on-one interviews with HP executives. However, things began the week before the show in our *HP Professional* offices with a visit from Carol Mills, general manager for HP's General Systems Division. Mills came to announce that HP is releasing the first HP 9000 servers based on the 64-bit PA-8000 CPU (see this month's Industry Watch).

Mills thinks that in the future, there will be fewer than the five hardware platforms that exist now (Alpha, PowerPC, SPARC, RS/6000 and HP 9000). She predicts that by the turn of the century, there will be a "pervasive UNIX," obviously referring to HP and SCO's plans for a unified 64-bit UNIX OS. HP is betting on its relationship with Intel and the Merced chip they are co-developing, not co-developing, designing, helping with, or whatever, depending on whom you ask, to provide the "next generation CPU" for that one single UNIX. And of course, there's the Internet. Mills concluded our briefing by forecasting that "the distribution industry as we know it will go away." And she must speak for HP because the firm just announced the return of Ira Goldstein, Internet guru and chief Web weenie.

## ... MEANWHILE BACK IN THE MAGIC KINGDOM

Our first morning in Anaheim began with Glenn Osaka, general manager for HP's Commercial Systems Business Unit, who says it's time to "think of the industry as an ecosystem. In other words, it's biological." Always candid, Osaka admits he worries about Sun's perceived "halo" surrounding the Internet with Java.

Next, Rick Belluzzo picking up on Lew Platt's opening comments, emphasized a convergence of the enterprise, workgroup, small business and home office computing in the future. When asked if he had a message for HP 3000 users, who often feel left out of HP's future plans, Belluzzo said, "We recognize their importance and their investment." So take heart gang.

Later that day, Harry Sterling, general manager for HP's Commercial Systems Division, explained to me just how HP is "recognizing" what we here at *HP Professional* refer to as the "fanatical fringe." He pointed to PA-8000 CPU support with Release 5.5 of MPE/iX, as well as support for Java. "As UNIX and NT exist, so will the HP 3000 and NT coexist."

In a quieter moment away from the show, Nigel Ball, marketing director for HP's GSY, clued us in on "the social side" of HP computing. By the time you read this, HP will have made a joint announcement with the United Nations to bring the power of the Internet into "information ghettos" around the world, with the first system going live in Mexico in the last week of August. Our journey ended with an early morning interview with Dick Watts, vice president and general manager of the CSO. Watts told us that Comaq and the PC industry with their low cost, high volume business model keeps him awake at night. "They are changing the rules of the game." Watts should know. He was the former manager of the PPG, HP's PC division. When it comes to Sun's Java, Watts plans to leverage the "halo" by "first asking, 'What is Java?' then demonstrating a range of alternative solutions."

---

## NEW STUFF

*HP Professional* is pleased and proud to welcome Harry Sterling to its Editorial Advisory Board. And speaking of introductions, this month on our back page, we kick-start a brand new column — the Internet Digest. Written by Mark McFadden, who manages a Gopher server for the Wisconsin Department of Natural Resources, the column will cover the latest news and technologies about the Internet.



**Charlie  
Simpson**

[simpsoncm@cardinal.com](mailto:simpsoncm@cardinal.com)  
[www.hppro.com](http://www.hppro.com)

## INDUSTRY WATCH

George A. Thompson

**WHAT GOES UP,  
COMES DOWN IN Q3**

In August, HP reported a 26 percent decline in net earnings including the effect of exiting disk mechanism manufacturing (announced in July) for the third quarter of its fiscal year. HP cited slower order growth (although orders for the quarter increased by 8 percent), order cancellations in the disk mechanism business, a significant order decline in the components business and ordering patterns by resellers in the inkjet printer and PC businesses.

Lower demand for semiconductor test equipment and workstations also contributed to slower order growth. However, overall orders which amounted to \$8.7 billion (United States and international markets) increased 8 percent over the same period a year ago. And net revenue increased 18 percent. HP also noted that demand for HP OpenView and HP OpenMail products was strong.

**THE INTERNET:  
AS GOOD AS GOLDSTEIN**

HP, which has been struggling with getting out in front of the Internet bandwagon, announced that Ira Goldstein recently returned to HP to take on the newly created position of Internet technology officer and chief technology officer for HP's Computer Systems Organization. Goldstein left HP (as research and development manager for HP's former Technical Systems Sector) to join the Open Group Research Institute where he served as executive vice president and chief scientist.

This is a quite a coup for HP which currently finds itself behind Sun Microsystems in the Internet mindshare game. However, according to an exclusive interview with Dick Watts,

**NOW SERVING THE PA-8000**

HP is now releasing (by the time you read this) the first HP 9000 boxes based on the 64-bit PA-8000 CPU. The PA-8000 chip is finding a home in HP's existing D- and K-class Enterprise servers, which were first introduced earlier this year. HP is also dropping the PA-8000 into its T-class (the T600) and Enterprise Parallel Servers (the EPS21 and EPS31).

The HP 9000 D270 (\$22,260) and D370 (\$25,250), supporting up to two 160 MHz PA-8000 CPUs, are considered by HP to be entry-level platforms. The K250 (\$52,200), K260 (\$61,200), K450 (\$68,200) and K460 (\$77,200) are considered to be midrange platforms. The new D-class servers will be available November 1 from distributors and resellers. The new K-class servers are available immediately.

The T600 (\$95,000) will be available in the first quarter of 1997. The EPS21 will be available in the third quarter of 1996, whereas the EPS31 will be available in the first quarter of 1997.



**The 64-bit PA-8000 CPU is now available in the D- and K-class models of the HP 9000 Enterprise Server product line.**

HP's vice president and general manager for HP's Computer Systems Organization, he sees a "huge opportunity to deliver value-added services on the Internet. For example, we have a large and growing Internet practice [referring to HP's new Internet Consulting Service]. So we are very excited to have Ira come back to HP."

Prior to his work at HP, Goldstein was a scientist at Xerox's Palo Alto Research Center (PARC) working on the integration of object-oriented languages with artificial intelligence (AI) techniques and on the creation of AI-based personal information environments. In 1986, Goldstein was selected by *Science Digest* as one of the nation's top scientists under 40.

**A PC BRIDGE OVER  
THE RIVER UNIX**

Even if you've been living in a cave or just haven't been able to pull yourself away from the Internet, you must know by now that HP intends to be a serious player in both the RISC and Windows/Intel server markets. So, in August at HP World, HP formally introduced the Enterprise NetServer Operation (ENO) part of the Network Server Division, which is itself in HP's Personal Products Group (PPG), responsible for HP's PC servers and desktops.

Maria Cannon, who most recently was HP's worldwide marketing manager for the Commercial Systems



# BUILDERS

**THE BEST TOOLS BUILD  
THE BEST REPORTING SYSTEMS.  
CALL THE BUILDERS.**



## INTRODUCING FOCUS SIX VISUAL BUSINESS INFORMATION SUITE

FOCUS is already the standard for enterprise reporting systems at thousands of the world's leading corporations. And now Information Builders introduces **FOCUS Six**, our next generation of client/server reporting tools that set totally new standards for power, efficiency and versatility.

**FOCUS Six** tools satisfy the reporting and analysis requirements of any user in the enterprise...from power-user analysts to front-office executives. **FOCUS Six Reporter** provides comprehensive ad hoc reporting with the ability to slice, dice and present data in almost any way imaginable. **FOCUS Six Managed Reporter** gives IS and department administrators the control they need while offering users sophisticated reporting and analysis in a simple, managed

environment. **FOCUS Six Report Server** lets you distribute all or selected parts of your reports via today's most popular e-mail systems. And **FOCUS Six EIS Edition** combines the legendary data crunching capabilities of FOCUS with today's most intuitive EIS interface.

All **FOCUS Six** reporting systems offer a unique three-tier architecture that automatically partitions application, database, and presentation logic to guarantee maximum efficiency and prevent network overload. And **FOCUS Six** can front-end any database, relational or legacy, making it the perfect choice for your data warehouse and other enterprise reporting systems.

For more information and a free **FOCUS Six** product brochure, call 800-969-INFO.

<http://www.ibi.com>

**800-969-INFO**

In Canada Call 416-364-2760

**Information  
Builders**

FOCUS Six trademark of Information Builders, Inc., NY, NY 212-736-4433 E-mail: info@ibi.com WWW: http://www.ibi.com

CIRCLE 247 ON READER CARD

Division (responsible for HP's PA-RISC/UNIX systems) has been named general manager of the ENO. During an interview with Cannon, she said one of her top priorities will be establishing a Partner Program which will work with top-tier PC application software companies to optimize Windows NT for HP's NetServer.

## BEATING A PATH TO 64-BITS

For those a little nervous about HP's move to its highly touted next generation architecture, HP has published a time schedule. Although still a bit nebulous, a full 64-bit HP-UX implementation is expected to be introduced by the middle of next year. Stay tuned.

Expected Announcement Date	HP-UX Version	Significant Features
February 96	10.10	file system size increased from 4 GB to 128 GB
September 96	10.20	file size to increase from 2 GB to 128 GB, 64-bit integer calculation, PA-8000 support
mid 97	11.00	full 64-bit implementation, PA-8200 support, next generation UNIX OS APIs
later 97	—	PA-8500 support, additional next generation UNIX OS
1998	11.x	Intel Merced (IA 64-bit) support
To Be Announced	12.0	Next Generation UNIX OS (based on HP/SCO 3DA)

## ALL IN A DAY'S WORKSTATION

While HP gears up for enterprise PC computing, Compaq (Houston, Texas), which has announced its intention to reinvent itself as a global enterprise-wide computer supplier (a la HP), announced the formation of a new Workstation Division within Compaq's newly created Enterprise Computing Group. Chartered to provide industry-standard (read Intel/Microsoft, a.k.a. Wintel) NT-based workstations at costs lower than competitive RISC/UNIX workstations, the new division plans a new worldwide series of systems before the end of this year.

As a part of their plan, Compaq is working with key ISVs in the areas of

3D animation, CAD/CAE, content development and financial services. Compaq is already forging new relationships with ELSA Inc. and Intergraph Computer Systems, two established leaders in the 3D/CAD/CAM and visualization markets.

## HP 3000: ALIVE AND WELL IN HP'S WORLD

During the HP World conference and exhibition in Anaheim, Calif. in early August, HP announced the following products and product plans for the HP 3000:

- MPE/iX 5.5 with high availability and improved networking features has been released.

- HP licensed ODBCLink for IMAGE/SQL and ALLBASE/SQL from M.B. Foster Associates. ODBCLink will provide 32-bit ODBC connectivity between HP 3000 servers and Windows 95 and Windows NT clients. When available, it will be automatically shipped to all customers with current IMAGE/SQL and ALLBASE/SQL support contracts.

- Bowing to the customer demands of HP 3000 purists who find themselves constantly at odds with HP's emphasis on UNIX and NT systems, HP announced plans to bring the PA-8000 CPU to the HP 3000. A formal product introduction is expected before the end of this year.

- A much requested ftp enhancement to simplify transfer of MPE file types, support for larger networks and 100 Mb technology for the HP 3000 was also promised to arrive later this year.

- HP also announced that Sun's Java would run on MPE/iX. Although unclear about its availability, HP will be working to "prepare Java for the rigorous demands of business-critical environments."

- HP also announced that it would — by the end of 1997 — enhance MPE/iX and related subsystems to address the "Year 2000" issue.

## HP-UX: THE NEXT GENERATION

No one knows for sure what the future will hold. But if Santa Cruz Operation (SCO) and HP have their way it will look a lot like this: a merged version of HP-UX and UnixWare running on Intel's pending 64-bit Merced CPU.

Moving aggressively to that end, HP and SCO announced the initial API specification for their next-generation 64/32-bit UNIX systems has been released for review to strategic software developers and systems suppliers.

In the first phase of the API specification process, strategic ISVs and OEMs — including many of the world's leading UNIX system vendors — are expected to review the first release of the API specification and provide HP and SCO with detailed feedback on features and functionality.

Ongoing updates for this release will be made throughout the next two months, with a new version for wider review expected early in the fourth quarter. A published version of this API specification is expected to be available by the end of the year. SCO plans to support this API specification in its upcoming release of "Gemini," the consolidation of SCO OpenServer and SCO UnixWare, which is expected to be available in mid-1997 (see below).

## AND SO IT BEGINS ...

In late July, HP announced that it would incorporate the initial 64-bit API specification in the next release of HP-UX, HP-UX 11.0, which is expected to be available in mid-1997. Optimized for the Intel IA-64 Merced microprocessor and based on the previously announced 3-Dimensional Architecture (3DA), the UNIX OS will provide a single development and porting target for 32-bit and 64-bit applications, enabling OEMs and ISVs to accelerate their delivery of a wide range of innovative customer solutions.



# LETTERS

## LOOKING AT ALTERNATIVES

I just finished reading [Jill Huntington-Lee's] article "An Event-ual Winner" in the July 1996 edition of *HP Professional*, and wanted to let her know that Tivoli/IBM Systems has had a product called the Tivoli Enterprise Console shipping for the last year or so that does exactly what she desired in terms of consolidation and correlation of events across the disciplines of network, systems, database and application management.

Kiron D. Bondale  
System Management Analyst  
Enhance Systems Inc.

Thanks for your message. I am familiar with Tivoli Enterprise Console, and have written several technical reports comparing it to other event/console managers.

While the general idea is the same, the implementation is quite different. I encourage you to learn more about HP event correlation services, as the approach to correlation is fundamentally different, and a person in your position may find it valuable to understand both the pros and cons of each approach. —JHL

## EASY TO SWALLOW

Good article [Editorial, July 1996]! Lots of food for thought and pretty brave questions about the nature of employee/employer relationships. There is, after all, a down side to downsizing. Keep cutting close to the bone.

Ralph Godwin  
Senior Applications Analyst/Programmer  
Harvard University Development Office

Address letters to HP Professional,  
1300 Virginia Dr., Ste. 400,  
Fort Washington, PA 19034.  
Fax: (215) 643-4827. Internet:  
SIMPSONCM@CARDINAL.COM

Letters may be edited

Check out  
HP Professional's  
Online edition at  
[www.hppro.com](http://www.hppro.com)

## Make Performance Tuning Easy With SarCheck™

### Understand exactly what's happening!

SarCheck translates pages of sar output into a plain English report, complete with system tuning and hardware upgrade recommendations.

### Maintain full control!

SarCheck fully explains each of its recommendations providing you with the information you need to make intelligent, informed decisions about your system.

### Plan for future growth!

SarCheck's Capacity Planning feature helps you to plan for growth, before slow downs or problems occur.

**Now available for HP-UX versions  
9.04+ and 10.x — call or fax today!**

(SarCheck for HP-UX 9 is available on 800 series only)



**AURORA  
SOFTWARE INC.**

PO Box 1033 Plaistow, NH 03865  
Voice (603)382-4200 Fax (603)382-4247



CIRCLE 181 ON READER CARD

## Protect Your Data & Pick Up the Pace with ...

# RAID RUNNER™

Don't fall behind the pack. Safeguard your computer's data with RAIDRUNNER, the disk array that clears RAID price-to-performance hurdles with ease. Get the safety & performance of RAID 3 and 5, plus capacities that go the distance - from 5GB to over 30GB.

**What are you waiting for?  
On your mark, get set, go...  
RAIDRUNNER!**

### Supported Operating Systems

- HP-UX • MPE • Digital UNIX™
- Windows NT™ • Windows • NetWare®
- AIX • SunOS • Solaris • and others



The Pacesetter in RAID Protection & Value  
for Networking and Desktop Computing

U.S.A. toll-free, call **800.237.4641**  
Outside the U.S.A. dial **408.364.6500**  
or e-mail us at [info@bering.com](mailto:info@bering.com)

**Bering**

©1996 Bering Technology - All rights reserved. All brand names and product names are trademarks or registered trademarks of their respective holders.

CIRCLE 194 ON READER CARD

SEPTEMBER 1996 11

# Never Out On A Limb With RoadRunner

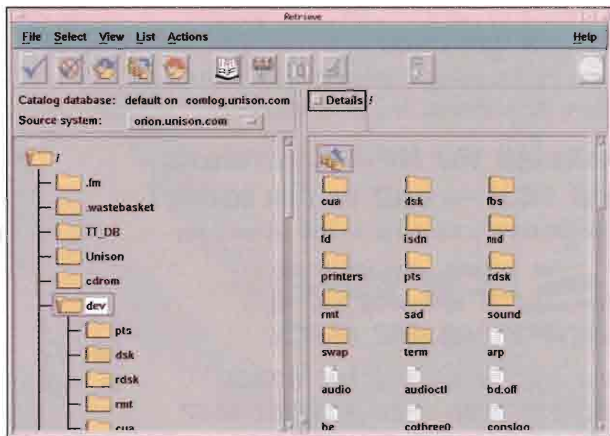

## ROADRUNNER RELEASE 3.0

- ▶ Integrated with HP OpenView IT/OperationsCenter
- ▶ Supports HP 9000/700/800 HP-UX, IBM RS/6000 AIX, Sun SPARC Solaris and SunOS 4.1.3, and SGI IRIX 5.2 and 5.3
- ▶ Base price is \$4,000

### Unison Software

5101 Patrick Henry Dr.  
Santa Clara, CA 95054  
tel: (408) 988-2800  
fax: (408) 988-2236  
info@unison.com  
www.unison.com

CIRCLE 353 ON READER CARD

Release 3.0 of RoadRunner includes a new fault-tolerant catalog management capability, which is part of Unison's strategy to address organizations' growing needs in the storage management arena. Administrators can manage backup and recovery of data from a Motif-based GUI or from an intuitive command line interface with a command line editor. RoadRunner's architecture allows system administrators to fine-tune performance factors through configurable data compression, parallel backup, data interleaving, tape indexing and configurable block sizes.

Delta Dental Plan of Massachusetts (Medford, Mass.), a provider of dental insurance in Massachusetts,

needed to ensure that their entire HP-UX environment, including operating system, data files and an Oracle database of financial information, was backed up in less than two hours. For Joe Short, HP system administrator at Delta Dental, that meant using Unison Software's (Santa Clara, Calif.) RoadRunner 3.0 in conjunction with DLT for high-speed backup. Short has been using RoadRunner on an HP K400 for approximately one year. RoadRunner helps with nightly backups on the K400 as well as an HP E45, both running HP-UX 10.10.

In addition, Delta Dental relies on Unison's Maestro's advanced job scheduling capabilities to schedule the RoadRunner backups and monitor network applications. Maestro's job dependency feature also ensures that the Oracle database is shut down prior to running the backups.

With RoadRunner, backup and recovery management for the entire network can be executed from a single, independent workstation, or it can be distributed across the network for local administration. Backup to locally-attached storage devices or to devices on multiple systems throughout the network is supported. Also, flexible con-

sole handling allows operator requests to be directed to the backup device server or to the client where the data resides.

With the catalog management features, the location of catalogs is configurable and independent of the device server. Users can select the catalog type — hierarchical, fault-tolerant, mirrored or local. The volume management capability also allows users to add, label and change the status of volumes. In addition to its advanced catalog management features, RoadRunner 3.0 also includes certification with Sony's DTF high-speed drive, and full integration with HP OpenView IT/OperationsCenter.

New features also enable customers to store online indexes or files, volumes and backups redundantly across the network, so they can quickly locate and retrieve data in the event of a system failure or malfunction.

Overwrite protection is ensured through the use of ANSI-standard tape labeling, and security is maintained through standard UNIX security as well as the preservation of UNIX's ACLs.

—Deborah Schwartz,  
Associate Editor



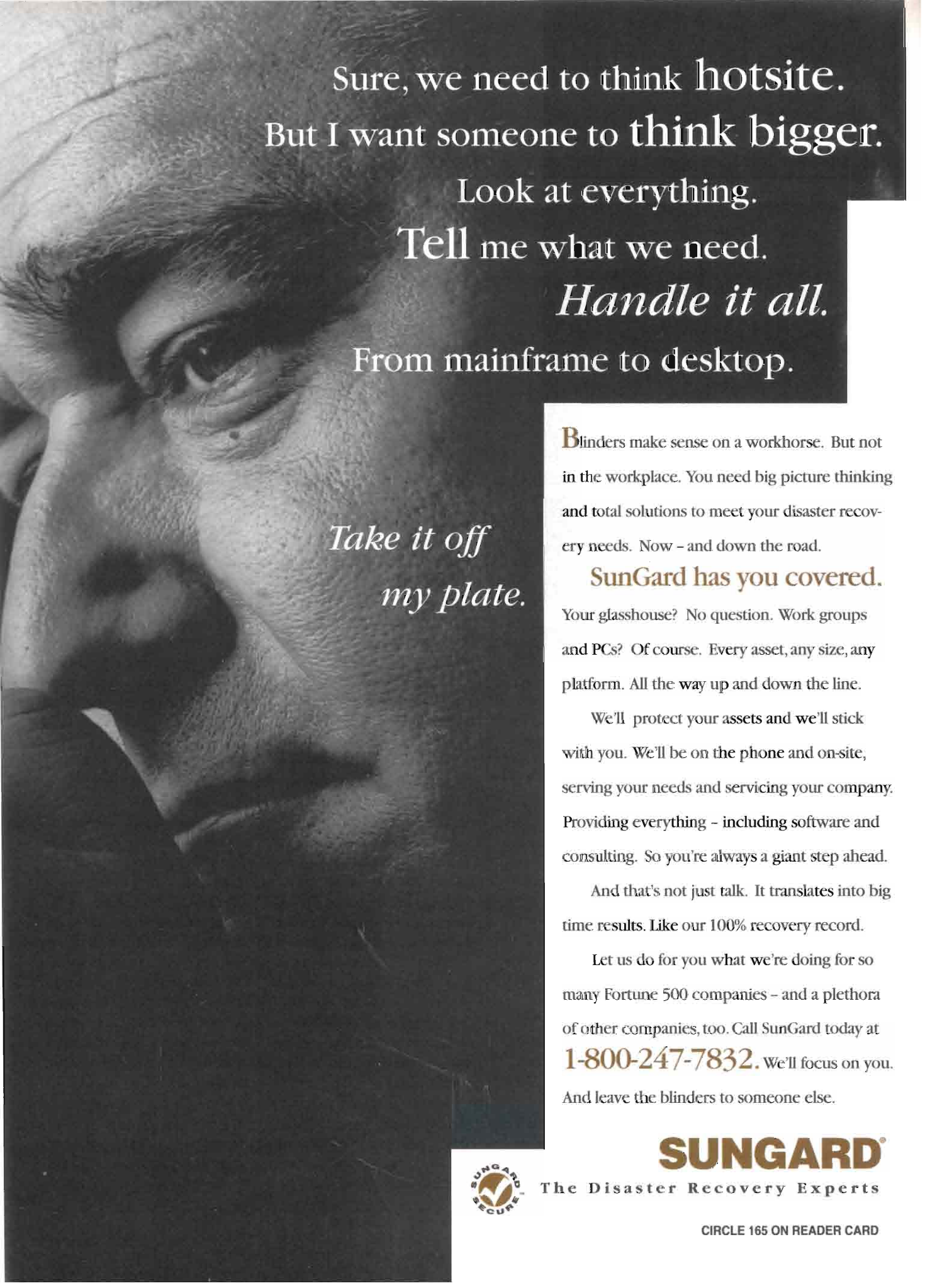

Sure, we need to think **hotsite**.  
But I want someone to **think bigger**.

Look at everything.  
Tell me what we need.

*Handle it all.*

From mainframe to desktop.

*Take it off  
my plate.*

**B**linders make sense on a workhorse. But not in the workplace. You need big picture thinking and total solutions to meet your disaster recovery needs. Now - and down the road.

**SunGard has you covered.**

Your glasshouse? No question. Work groups and PCs? Of course. Every asset, any size, any platform. All the way up and down the line.

We'll protect your assets and we'll stick with you. We'll be on the phone and on-site, serving your needs and servicing your company. Providing everything - including software and consulting. So you're always a giant step ahead.

And that's not just talk. It translates into big time results. Like our 100% recovery record.

Let us do for you what we're doing for so many Fortune 500 companies - and a plethora of other companies, too. Call SunGard today at **1-800-247-7832**. We'll focus on you. And leave the blinders to someone else.



**SUNGARD**<sup>®</sup>

The Disaster Recovery Experts

CIRCLE 165 ON READER CARD



# Happy Trails To You With WSM

power outage or fan failure is reached, the condition is displayed within the browser. WSM also integrates with SNMP-based products.

Mike Stelzmer, marketing and communication manager at Andataco, says the company found problems not with the devices inside but with the enclosures themselves. "Typically the system breaks down before the system lights up and tells you there is a problem. ESP is truly proactive in anticipation of events." Both WSM and ESP support HP-UX, IBM AIX, SGI Irix, SunOS and Solaris, and Windows NT.

With a click of a mouse, WSM allows administrators to access a host incorporating an ESP subsystem anywhere on the network for information about the vendor of the disk, firmware level, SCSI ID, capacity and mounted partitions. Administrators can then mount, label, partition or format a disk as well as take it on/offline. The WSM program has e-mail and paging technology available, as well as the ability to power up or down individual devices from the GUI to fix or check on an established or potential problem. ESP and WSM were developed in parallel to work closely with one another.

A zero stub-length design based on SCA technology is Andataco's answer for high performance, while a cableless design with a high degree of redundancy, a passive midplane, self-maintenance capabilities and sophisticated monitoring, shutdown, alarm and recovery mechanisms provide fault-tolerance. The company hopes to achieve flexibility with a building-block architecture that allows scalable configurations ranging from a single device in a desktop enclosure to data center cabinets housing up to 120 removable storage elements.

WSM costs \$995. The ESP has four basic sizes: a desktop tower, deskside tower, rackmount chassis and a data center. Price varies for each depending upon the inclusion of a split bus or single bus, 3.5-inch or 5.25-inch removable storage units and their size. The desktop tower ranges from \$786 to \$1,170, while the deskside tower ranges from \$3,013 to \$3,995 and the rackmount chassis ranges from \$2,542 to \$3,240. The data center ranges from \$22,232 for seven racks and the least expensive chassis to \$54,540 for 15 racks with the most expensive chassis.

—Matt Hengey, Associate Editor

## WEB STORAGE MANAGER

- ▶ Monitors and controls storage systems via the Internet or intranet.
- ▶ Integrates with SNMP-based products
- ▶ Price is \$995

### Andataco

10140 Mesa Rim Rd.  
San Diego, CA 92121  
tel: (800) 334-9191  
fax: (619) 453-9294  
inquire@andataco.com  
www.andataco.com

CIRCLE 351 ON READER CARD

For system administrators looking to get out of their seats but not loose touch with their system, Andataco (San Diego, Calif.) says "happy trails." The company released their Web Storage Manager (WSM), an application designed for monitoring and controlling storage systems from a local server via the Internet or an intranet.

WSM works in conjunction with Andataco's Enterprise Storage Packaging (ESP) subsystem, which reports on and can control system devices. The information gathered is reported back to the WSM host-based Web server application, which is then displayed and controlled via a Netscape browser. When an alarm condition such as over-temperature,



**X** Your computing platform of choice is HP, because it gives you the functionality and flexibility

you need.

But can you say the same about your

printing systems? As the

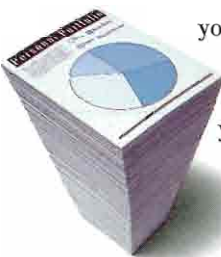

# WHO INVENTED THE LASER PRINTER?

Which means you get quality documents where and when you want them.

It's part of our Open Print Systems

vision to deliver quality print anywhere in virtually any enterprise.

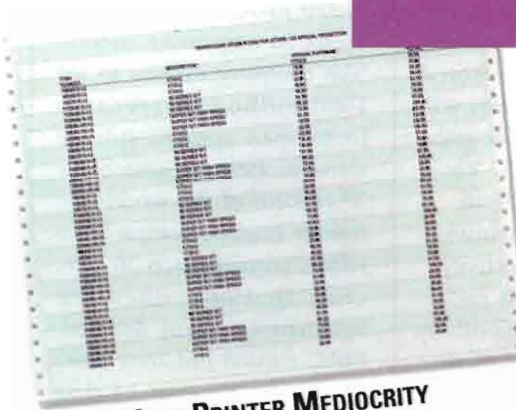

## LINE PRINTER MEDIOCRITY

inventors of laser printing, our years of experience and technology development means no one offers faster, more flexible and cost-efficient laser printers for HP environments.

### Choices. Choices.

Whatever applications you run on the HP platform, our mid-range, cut-sheet, laser printing systems give you more flexibility than traditional line printers. With high quality black and white, color, and MICR output,



they can handle multiple data streams, have advanced paper-handling capabilities and provide a variety of connectivity options. We've even developed software solutions that make



THE DOCUMENT COMPANY  
XEROX  
Worldwide Sponsor

them easier to use and manage.

### The Xerox Midrange Printer Family.

The Xerox 4215/MRP, 4219/MRP, 4220/MRP & 4230/MRP printers share a common architecture so you can seamlessly switch applications to the best choice printer.

### Think Laser. Think Xerox.

For the perfect laser printing system for your HP platform, remember who invented laser printing in the first place. Because we have more choices. So talk to your Xerox Marketing Affiliate. Or, for a white

## LASER PRINTER BRILLIANCE

MODEL	DESCRIPTION	MAXIMUM PRINT SPEED (PPM)	MAXIMUM PRINT SIZE	MAXIMUM RESOLUTION (DPI)	MAXIMUM SHEET SIZE	MAXIMUM SHEET WEIGHT (GSM)	MAXIMUM SHEET THICKNESS (MM)	MAXIMUM SHEET LENGTH (MM)	MAXIMUM SHEET WIDTH (MM)	MAXIMUM SHEET WEIGHT (KG)
XEROX 4215	4215/MRP	18	A4	600	216 x 279	75	0.18	297	216	0.018
XEROX 4219	4219/MRP	18	A4	600	216 x 279	75	0.18	297	216	0.018
XEROX 4220	4220/MRP	18	A4	600	216 x 279	75	0.18	297	216	0.018
XEROX 4230	4230/MRP	18	A4	600	216 x 279	75	0.18	297	216	0.018

paper on midrange printing systems, call

**1-800-ASK-XEROX, ext. 226.**

# THE SAME PEOPLE WHO CREATED QUALITY PRINTING CHOICES FOR HP ENVIRONMENTS.

THE DOCUMENT COMPANY  
XEROX

XEROX® The Document Company® and the stylized X are trademarks of XEROX CORPORATION. Contact Xerox for details on the Total Satisfaction Guarantee. 50 USC 380. The product names used herein are trademarks of their respective owners. XEROX products mentioned herein may contain recycled, remanufactured parts.

CIRCLE 115 ON READER CARD

# At The Store Front

## EMC's Symmetrix 3000 Captures Data And Market Share



"EMC has fundamentally shifted the landscape in the rapidly growing open storage market."

**Michael C. Ruettgers**  
CEO  
EMC<sup>2</sup>

**EMC<sup>2</sup>**  
P.O. Box 9103  
Hopkinton, MA 01748  
tel: (508) 435-1000  
fax: (508) 435-6912  
www.emc.com  
CIRCLE 352 ON READER CARD

**A**lmost a year into a reseller agreement with worldwide storage leader EMC<sup>2</sup> (Hopkinton, Mass.), HP is finding that EMC Symmetrix 3000 ICDA (Integrated Cached Disk Array) storage systems reinforce the HP 9000's position as a mainframe alternative. And now, the agreement has been expanded to support the HP 3000 as well. HP and EMC signed the \$160 million agreement, which extends to mid-1997, in November 1995 after working together to create a world record-sized data warehouse at EMC's labs in Milford, Mass.

So far, the HP-EMC tie has been a success; \$100 million in revenues was generated in the first six months of 1996. The company is banking on the HP 9000 platform, because it plans to grow sales based on open, client-server systems. EMC has grown by leaps and bounds since the inception of Symmetrix systems in 1990. For multiconnected, scalable, fault-resilient, open storage, Symmetrix ICDA systems range in capacity with models from 35 GB capacity to 1,118 GB.

The systems are based on a development architecture the company calls Mosaic: 2000, their proprietary tech-

nology which allows easy upgrades in hardware and code.

EMC asserts that the amount of digital information that will need to be stored over the next five years will double that which was gathered over the last 35. Thus, the Symmetrix 3000 is designed with continuous availability and connectivity.

With up to 4 GB cache, intelligent caching algorithms and disk mirroring, Symmetrix 3000 systems guarantee high performance and continuous availability of data. Up to 32 SCSI channels guarantee standard, multithost connectivity.

So far, the only hurdle has been price. EMC's high-end Symmetrix 5500, revamped to work with mainframes and open systems, bests rivals IBM and Storage Technology in price per unit. But with the Symmetrix 3500 price as high as \$2.4 million (the low-end starts at \$805), depending on configuration, the client-server solutions are hardly an inexpensive choice.

For the most part, its largest customers, like The Coca-Cola Company, Delta Airlines and UPS, strongly endorse EMC. But because of the company's rapid growth, stories about an overly aggressive sales with a "take no prisoners" attitude

have cropped up casting doubts about EMC's commitment to quality.

But EMC makes no bones about its aggressive nature. The company expects to see \$600 million in revenues from open systems storage alone in 1996. It now owns 37 percent of the worldwide storage market, compared to IBM's second-place 36 percent. In 1990, when the Symmetrix systems debuted, EMC owned just over one-tenth of a percent of that worldwide market. "EMC has fundamentally shifted the landscape in the rapidly growing open storage market," says Michael C. Ruettgers, CEO of EMC.

Growth, a constant factor at EMC, did decelerate in 1995, raising questions briefly on Wall Street, and urging company officials to push harder. Ruettgers probably put the company's philosophy best last December when he told the *Los Angeles Times*, "What we try to do is run the business in the best interest of the [company]. If I ran the business to keep Wall Street happy all the time, I'd end up in a strait jacket."

—Barry Slawter,  
Contributing Author



**UNIX users** can  
now add Windows to their list of conquests.  
(Consider all ties with humility severed.)

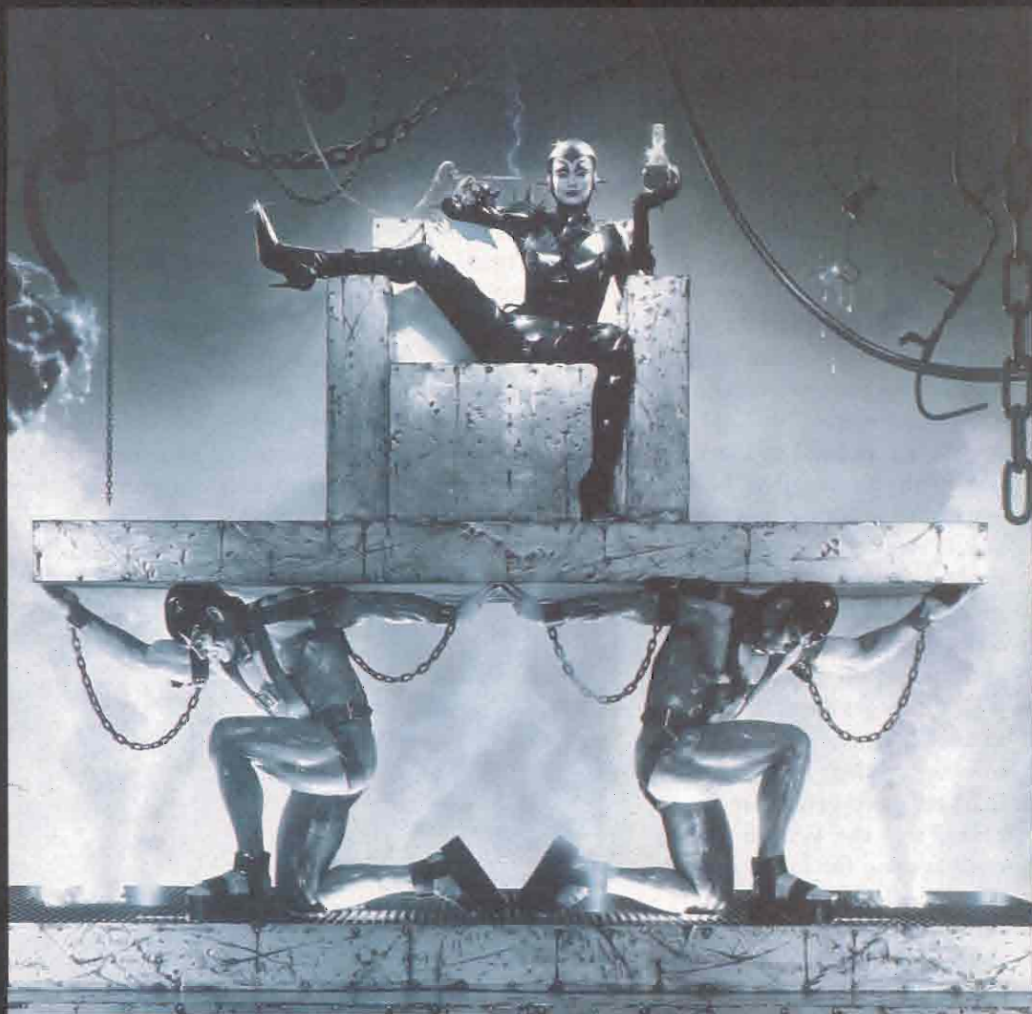

It's almost as if your workstation went out and ate a PC for lunch. New SoftWindows™ for UNIX 2.0 gives power users complete control over all Windows® and MS DOS® applications. So, you can share your wisdom with the Windows-using masses, without actually having to operate their primitive equipment. (Can you imagine?) Call 1-800-848-7677 today, or visit us at <http://www.insignia.com>. **INSIGNIA SOLUTIONS**. Because communicating with the common man shouldn't mean using his hardware.

Insignia Solutions is a registered trademark of Insignia Solutions Inc. SoftWindows is a trademark used under license. MS DOS and Windows are registered trademarks of Microsoft Corporation. UNIX is a registered trademark licensed exclusively through X/Open Company, Ltd. ©1996 Insignia Solutions Inc.

CIRCLE 218 ON READER CARD

# Investing In Better Performance

*BEA Associates And Camelot Music Improve Reliability And Speed With A Database Accelerator From Database Excelleration Systems.*

*Scott R. Humphrey*

BEA Associates, a New York, N.Y.-based investment management firm, solved its crucial system availability problem by moving Sybase tempdb on to a solid-state database accelerator from Database Excelleration Systems (DES; Santa Clara, Calif.). Daily system crashes of its production portfolio management and accounting database, caused by heavy system use and contention for resources, have been eliminated.

"As we headed toward the end of the trading day, I could guarantee you that our Sybase server was going to crash," recalled Steve Buckridge, senior vice president of systems and technologies for BEA Associates, a division of Credit Suisse, which manages about \$28 billion in assets. "Everybody was trying to wrap up their trades as some markets were getting ready to close, and the system would crash because the log in tempdb was filling up.

"Every day was a crisis," Buckridge continued. "We got very good at identifying what reports not to run at particular times to minimize the system crashes, but the overall management of the application got to be more of an art than a science, which was unacceptable. We had tried everything Sybase suggested to ease the contention issue, but nothing worked. Then we moved tempdb on to a

Database Excellerator from DES and our system has not crashed since."

## ON TIME, EVERY TIME

BEA's 8 GB Sybase SQL Server 4.92 database running on a four-processor HP 9000 K400 database server is the information backbone of the company, supporting BEA global trading. The system runs 24 hours a day, 7 days a week. "We run about 22 hours each day in production mode, while the remaining two hours the system is offline taking backup," said Buckridge. "From a systems standpoint, it is to a large extent the lifeblood of the

company. It supports all aspects of the investment operation."

That might be an understatement. The Sybase database allows portfolio managers to perform "what if" scenarios. It's also used on the trading desk to support the trading activity, by the settlement area for the electronic settlement of trades, by the auditing area for the reconciliation of portfolios, by the client reporting group for the production of statements addressed to the clients, by the security file administration areas to set up securities and online restrictions for portfolios, by the compliance group for guidelines and by the

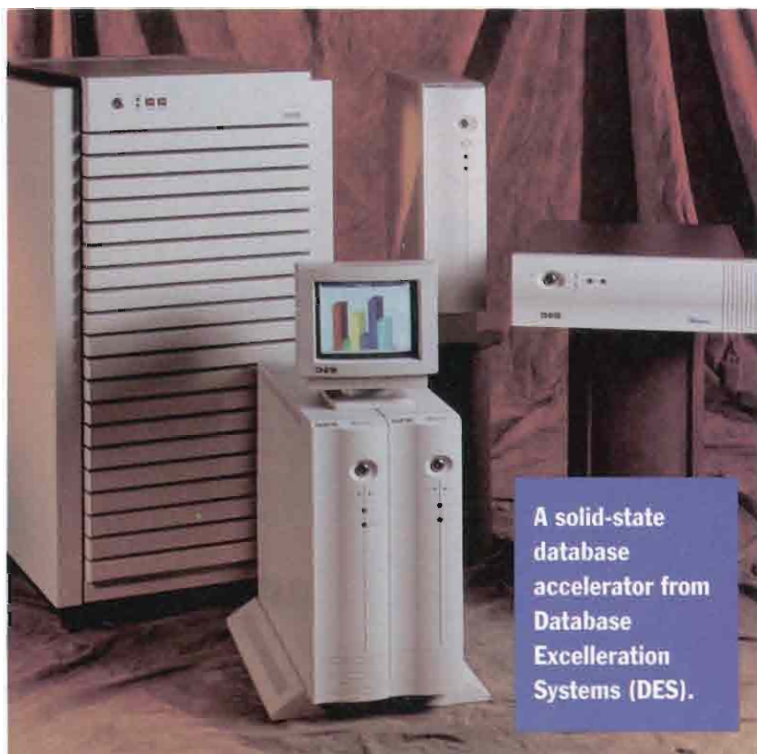



KEA!™ 700/98 for HP®

Now there is a choice  
**for HP**  
connectivity  
and the choice  
is clear



Trade-up to KEA! 700/98  
for HP for \$99!\*

Introducing the superior  
choice for HP connectivity.

Attachmate® now gives you a choice for HP connectivity with the launch of KEA! 700/98 for HP. It's the only software for **HP 3000, HP 9000, and VAX®** connectivity – complete with **TCP/IP and NS/VT** protocols – right out of the box.

KEA! 700/98 for HP is a fully customizable, powerful **16- and 32-bit** connectivity solution, with support for OLE 2.0, HLLAPI and Shuttle File Transfers. Plus you get the flexibility of TCP/IP, NS/VT and **dial-out modem capability**, all for one incredibly low price.

Attachmate leads the industry in providing dependable host access – and we back every product with our world class customer support.

So whether you're upgrading to **Windows® 95 or Windows NT®** now or later on, KEA! 700/98 for HP is the right choice if you're serious about your HP connectivity solution.

To qualify for your free evaluation copy of **KEA! 700/98**

for HP, or other Attachmate products, call **800-426-6283** or **206-644-4010** and mention response code **558.00**.

For information on our Open Systems Medallion Program for Preferred Resellers call **604-294-9499**.

Or visit our Web site at **www.attachmate.com**

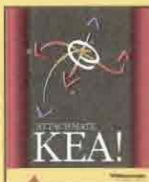

ATTACHMATE  
**KEA!**  
700/98 for HP

\* Limited time offer for users of competitive HP connectivity software.

© 1994 Attachmate Corporation. All Rights Reserved. Printed in USA. Attachmate is a registered trademark and KEA! is a trademark of Attachmate Corporation. HP is a registered trademark of Hewlett-Packard Company. Windows and Windows NT are registered trademarks of Microsoft Corporation. VAX is a registered trademark of Digital Equipment Corporation. All other trademarks or registered trademarks are the property of their respective owners.

CIRCLE 497 ON READER CARD

**Attachmate**  
The Intranet Company

marketing department in pitching new clients. BEA uses a Novell NetWare 3.1 network to support its 200 user system, with 150 simultaneous users the norm. The database is stored on conventional disk subsystems running Fast Wide SCSI.

BEA maintains two identical HP database servers to ensure data availability, but also to provide timely access to historical data. "In our environment, where timelines are key, there is no reason for anybody to tie up our production database by making historical inquiries," Buckridge said. "Sybase doesn't necessarily operate very well if an auditor decides they need to see transactions for the last year on a portfolio," Buckridge quipped, "so we maintain one server for production and another for historical queries. Historical is yesterday."

### A PAIN IN THE BOTTLENECK

All BEA temporary work files are stored in tempdb, which exceeds 1 GB daily. "tempdb was creating a major I/O bottleneck for us," Buckridge said. "The way we got around the bottleneck was by having the car that it rides in be capable of much higher speeds, and that's where DES fits into the picture. By moving tempdb on to the DES system, we have eliminated the I/O bottleneck, thus eliminating our system crashes.

"Our daily crashes were beginning to affect the firm's ability to efficiently conduct its business," Buckridge continued. "In some markets we serve, settlements must occur within 24 hours, otherwise the firm is fined 100 percent of the value of the transaction. The DES system has greatly assisted us in stabilizing and enhancing our database environment. The business benefit resulting from this is that we now get trades entered into the system and out

in a timely manner, as well as get the information out to the banks and brokers who need to have the trading information as well."

BEA added the current HP database servers in the fourth quarter of 1995, replacing 10-processor Pyramid systems. The CPU upgrade has gained them an additional five-fold performance improvement. Because the DES systems are SCSI-based, BEA was able to move the two DES systems to the new UNIX environment without modification. "The transition in taking the DES systems over to the HP 9000s

performance improvements and system stabilization may be realized by adding a solid-state system which improves access and response time to specific, highly used files or database tables."

### NO FAIRY TALE DISTRIBUTION

Camelot Music (North Canton, Ohio) faced a different problem. The music retailer, with 402 outlets located throughout 37 states, had conducted a simulated performance evaluation of its distribution system which showed that processing projected volumes from its stores would take 22 hours. With a



was flawless," Buckridge said. "We simply configured them for the new HP servers, and they were fully operational, so we were able to preserve our investment in the DES systems."

Dan Kusnetzky, research director of UNIX & Server Operating Environments with International Data Corporation (IDC; Framingham, Mass.), supports the concept of intelligent subsystems as well. "Organizations might find it most cost-effective to consider the addition of solid-state systems like those provided by DES rather than going through the time-consuming process of tuning the system memory, operating system, database network and the application, as these changes would not directly address the I/O contention issue," Kusnetzky said. "Significant

three-hour window required for archiving, Camelot knew it needed to dramatically improve system performance to meet anticipated demand.

Camelot's environment consists of a six-processor HP 9000 T500 with 1.25 GB of memory, Oracle 7.0 with 350 tables and 80 to 90 user log-ins, and Oracle Forms 3.0. In all, Camelot implemented nearly 90 process changes to build a faster system, including upgrading to Oracle 7.0, rewriting the company's order processing system from Alpha & Omega Integrated Control Systems, tuning the application and investing in two additional processors for its HP 9000.

According to Camelot Systems Manager Tim Oberschlake, the last piece of the puzzle was to solve the



I/O contention problem Camelot was experiencing with Oracle, especially on complex joins and queries. "Our operation is very data dependent, and as a result we have significant amount of database access, which is very I/O intensive," he said.

Camelot opted to solve the problem by storing its heavily accessed Oracle temp tables on a DES system. Accessing the temp tables via a high-speed DES system enables Camelot to perform complex queries and joins very quickly, conduct arbitrary sorts at very high speeds, as well as create indexes dynamically.

"We incorporated the DES system into our environment as part of an architectural upgrade to improve our Oracle database performance," Oberschlake said. "Our database is 60 GB so we obviously have a lot of disk, and we found we had a lot of issues with I/O contention in the database. Oracle treats the DES system like a disk drive, but it imposes virtually none

of the I/O delays associated with disk access," said Oberschlake. "We use it just on the heavily accessed areas of the Oracle database."

For example, Camelot had one particular Oracle SQL statement that was taking up to two hours to run. Camelot changed the SQL statement to use a sorting algorithm that took advantage of the DES system, and the statement ran in less than 10 minutes. "Anytime we sort or create indexes, it's blindingly fast," said Leif Fellague, Camelot's database administrator.

#### HAPPILY EVER AFTER

"System processors are not typically the bottleneck in database applications," said IDC's Kusnetzky. "The bottleneck is usually in the storage system. IDC has observed several companies focusing on intelligent storage subsystems like the DES system as a way to improve database application performance."

According to BEA's Buckridge,

relational database vendors still have not been able to address the I/O contention issue facing high-transaction and query-intensive environments. "Frankly, I think the I/O issue is currently best addressed by products like those provided by DES," he said. "You can design the hell out of a database, but I think each one of the relational vendors have their idiosyncrasies or parameters within which you must operate. The DES system has helped us solve our key Sybase idiosyncrasy."

"The credibility that we had lost within the organization was enormous," Buckridge said. "It's now a pleasure to come to work — our stock is very high at this point. We're being pulled into situations that we wouldn't have before because of our recent successful track record."

DES can be reached at (800) 287-0373, info@desdbx.com or www.desdbx.com.

—Scott R. Humphrey,  
Contributing Author

**Hit Us!**  
**Hit Us Hard!**  
**Hit Us Often!**



*A compilation of press releases and informational product announcements directed to the high technology market.*

<http://www.prtech.com>



**GE Capital**  
Computer Rental Services

**UNIX Workstation  
Rentals**

*Our Business Is Helping Yours®*

## Now's the Time to Rent the Newest UNIX Workstations!

- Cost-effective rental of the latest HP, Silicon Graphics, Sun, and Tadpole workstations:
    - HP C Class
    - HP Model 715
    - HP Model 735
    - Silicon Graphics Indy™
    - Silicon Graphics Indigo2™
    - Sun SPARCstation 5
    - Sun SPARCstation 10
    - Sun SPARCstation 20
    - Sun Ultra 1 Systems
    - Tadpole SPARCbook
- Plus new products available as released by manufacturers!*

- Large inventory – Fast delivery
- Flexible rental & leasing options—Rent-to-Own
- Major credit cards accepted

**Call 1-800-GE-RENTS!**

Authorized Rental Company For:



**HEWLETT  
PACKARD**



**SiliconGraphics**  
Computer Systems

**TADPOLE  
TECHNOLOGY**



**Sun Microsystems**  
Computer Corporation



CIRCLE 166 ON READER CARD



## DON'T GET CAUGHT WITH THE WRONG TAPE LIBRARY.

Especially since your company's business-critical data requires a serious, failsafe storage solution. A solution that can meet your needs today and tomorrow. That's why you should select a DLT automated tape library from the company that invented DLT automation over 4 years ago - the DLT automation leader - ATL Products.

ATL offers a broad range of field expandable models to choose from, with capacities ranging from 560 GB to over 9 TB, and library throughput speeds up to 162 GB per hour, it's easy to find just the right solution to meet your strenuous storage and user demands today, as well as tomorrow.

Another reason to trust ATL is its years of successfully meeting the DLT automated tape library needs of the midrange UNIX world. That's why, for its HP9000 server family backup system of choice, HP selected ATL Products as its exclusive DLT automated tape library reference partner.

So, when selecting a DLT automated tape library solution for your company, don't get caught with the wrong solution - choose experience, choose reliability, choose the recognized leader, choose ATL Products. Call now for more information about our complete line of DLT libraries and the name of an authorized reseller near you.



### DLT Automation Experience Counts

Reliability and data availability are the two most important factors when rating an automation system. ATL Products' years of automation experience has produced the Integrated Library system,



which combines features like the IntelliGrip cartridge handling system and ATL specified DLT drives, resulting in the industry leader in reliability and data availability. DLT experience counts!

**ATL**  
PRODUCTS  
AN ODETECS COMPANY  
**Quantum**



1515 S. Manchester Avenue, Anaheim, California 92802 USA  
800-677-6268 714-780 7790 <http://www.atp.com/>

CIRCLE 241 ON READER CARD



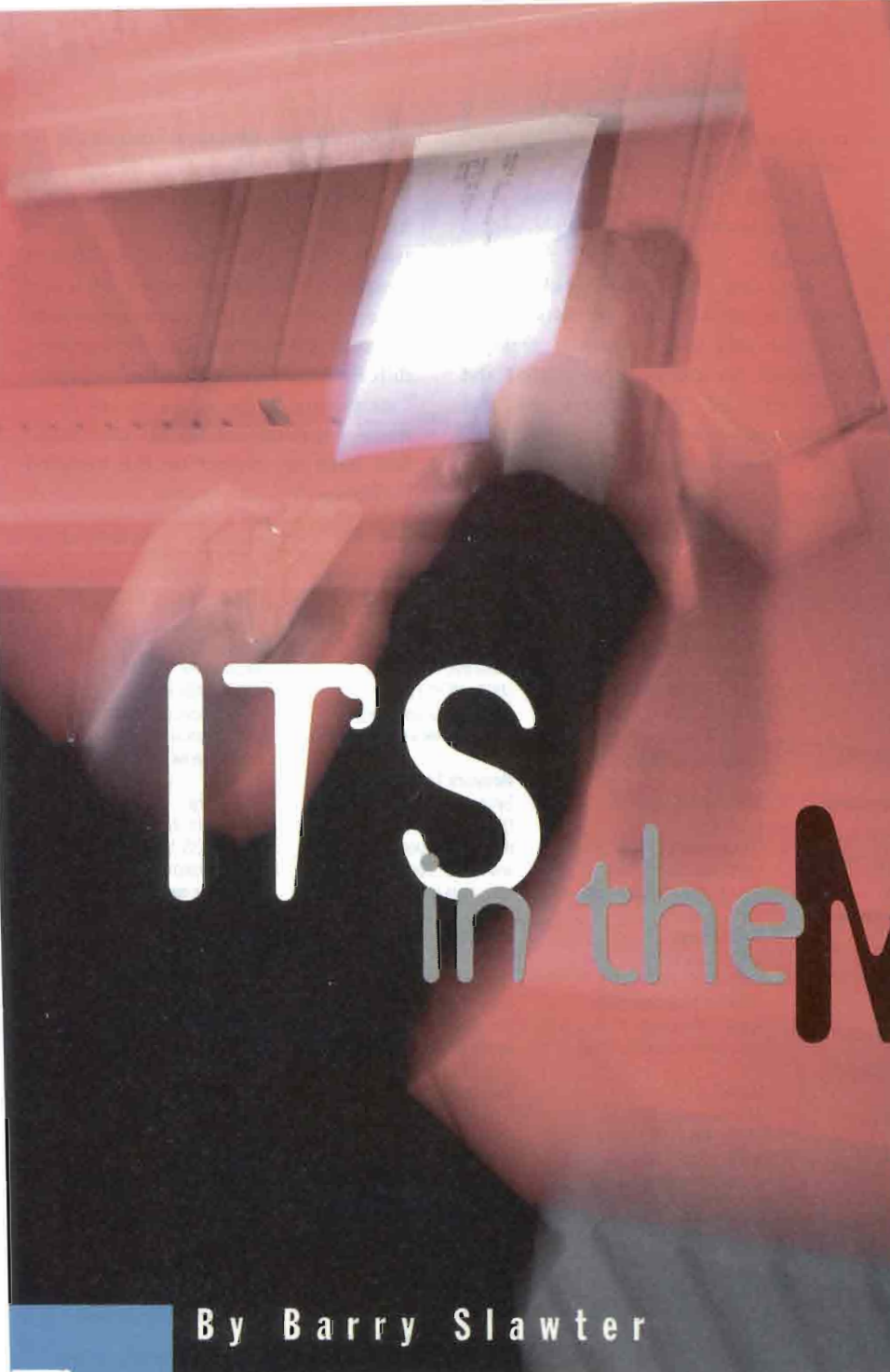

# IT'S in the MAIL

Electronic mail is no longer cutting edge. Or is it? A look at e-mail's important bit-part in a crazy new world of interactive messaging. ■

By Barry Slawter

The

World Wide Web captured the imagination of the public more than a year ago, bumping good old-fashioned apps like e-mail to the back pages of computer magazines forever. Go to any newsstand, and you will find entire publications dedicated to Web development; yet an article on e-mail technologies is treated like a white paper on Pong.

Still, everyone has a valid need for e-mail, which has come to be thought of as a mere throw-in feature on most Internet packages. In 1996, not having simple electronic mail is a business faux-pas in the high-tech sector, and not being able to communicate via an Internet connection spells doom.

In the world of office communication, e-mail is no longer

cutting-edge. Rather, it's an essential part of an overall messaging discussion, much in the way the phone and fax are.

Developing a messaging backbone seems to be an ever-increasingly difficult task. Now, your backbone must support a real bear of a list when it comes to communications services: text and binary messaging,

EDI, calendaring and scheduling, multimedia, document management, faxing and voice messaging, not to mention the necessity of a pragmatic approach to network management.

The Great Messaging Challenge then is really managing information overload — how to get all these darn bytes back and forth between talk-happy people, regardless of whether your immediate task is to translate effectively through mail gateways, or to bridge server platforms. E-mail is just a small part of a large puzzle. And so, whether you're choosing an e-mail package bundled in an Internet application suite (such as Spry's Internet-in-a-Box), an online service or an Internet-specific package, "openness" will naturally be your key consideration.

### DRIVING MS. BUSINESS

Messaging drives business, they tell us. And as it does so, our network worlds become more complex. This has led HP to adopt the following slogan for OpenMail: *One aim. One attitude. One rhythm. One end.*

Somehow, this seems to say as much about the problems facing us, as it does the solution. The slogan is based on "powerful team concepts that are the spirit and essence of *Taiko*, a tradi-

tional and spectacularly coordinated form of Japanese drumming."

See what you've gotten into? And you just want to send a simple e-mail message.

But, can an e-mail backbone be simple anymore? Einar Stefferud thinks you can still send a simple message. Stefferud, an independent analyst and one of the developers of the Multipurpose Internet Mail Extension (MIME) protocol, says a key to selecting an e-mail backbone is asking where

to put the infrastructural complexity or simplicity.

"I always suggest keeping it simple," he says, "with a model in open Internet systems of core [backbone] simplicity complemented by edge [client] complexity. Core simplicity makes it easier to interconnect between different entities within the network. Complexity at the edges means functional improvements to the user interface have no impact on the installed backbone."

## KEY E-MAIL PRODUCT AND SERVICE VENDORS

### Advanced Networking Concepts

Simi Valley, CA  
(805) 520-0300  
info@adv-net.com  
www.adv-net.com  
CIRCLE 346 ON READER CARD

### Attachmate Corp.

Cincinnati, OH  
(800) 348-3221  
www.attachmate.com  
CIRCLE 345 ON READER CARD

### Banyan Systems

Westborough, MA  
(800) 222-6926  
www.banyan.com  
CIRCLE 344 ON READER CARD

### Baranof Software Inc.

Watertown, MA  
(800) 462-4565  
info@baranof.com  
www.baranof.com  
CIRCLE 343 ON READER CARD

### CACI Products Co.

La Jolla, CA  
(619) 457-9681  
chris@caciasl.com  
www.caciasl.com  
CIRCLE 342 ON READER CARD

### Castelle Inc.

Santa Clara, CA  
(800) 289-7555  
CIRCLE 341 ON READER CARD

### Distinct Corp.

Saratoga, CA  
(408) 366-8933  
mktg@distinct.com  
www.distinct.com  
CIRCLE 340 ON READER CARD

### E-Mail Inc.

Pasadena, CA  
(818) 403-1999  
www.emailinchip.com  
CIRCLE 442 ON READER CARD

### Esker

San Francisco, CA  
(800) 88-ESKER  
info@esker.com  
www.esker.com  
CIRCLE 339 ON READER CARD

### Firefox Communications

San Jose, CA  
(800) 230-6090  
sales@firefox.com  
www.firefox.com  
CIRCLE 338 ON READER CARD

### Frost & Sullivan

Mountain View, CA  
(415) 961-9000  
dmiller@frost.com  
www.frost.com  
CIRCLE 337 ON READER CARD

### FTP Software Inc.

Andover, MA  
(800) 282-4FTP  
info@ftp.com  
www.ftp.com  
CIRCLE 336 ON READER CARD

### Goldmine Software Corp.

Pacific Palisades, CA  
(800) 654-3526  
74431.1624@compuserve.com  
www.goldminesw.com  
CIRCLE 335 ON READER CARD

### GRC International Inc.

Vienna, VA  
(800) 934-5917  
info@grci.com  
www.grci.com  
CIRCLE 334 ON READER CARD

### Ingram Micro

Santa Ana, CA  
(714) 566-1000  
www.ingram.com  
CIRCLE 333 ON READER CARD

### InterCon Systems Corp.

Herndon, VA  
(800) INTRCON  
sales@intercon.com  
www.intercon.com  
CIRCLE 332 ON READER CARD

### Microsoft Corp.

Redmond, WA  
(800) 426-9400  
www.microsoft.com  
CIRCLE 331 ON READER CARD

### NetManage

Cupertino, CA  
(408) 973-7171  
info@netmanage.com  
www.netmanage.com  
CIRCLE 330 ON READER CARD

### Nortel

Mississauga, ON  
(800) 4NORTEL  
www.nortel.com  
CIRCLE 443 ON READER CARD

### Novell Inc.

Orem, UT  
(800) 346-7177  
www.novell.com  
CIRCLE 329 ON READER CARD

### MCS Inc.

Pittsburgh, PA  
(800) 394-6271  
CIRCLE 328 ON READER CARD

### NCD Software Corp.

Beaverton, OR  
(503) 641-2200  
ncd@ncd.com  
www.ncdsoft.com  
CIRCLE 327 ON READER CARD

### Netframe Systems Inc.

Milpitas, CA  
(408) 474-1000  
www.netframe.com  
CIRCLE 326 ON READER CARD

### Netscape

Mountain View, CA  
(800) NETSITE  
home.netscape.com  
CIRCLE 314 ON READER CARD

### Network Telesystems Inc.

Santa Clara, CA  
(800) 990-4PRO  
info@ntsi.com  
www.ntsi.com  
CIRCLE 313 ON READER CARD

### ON Technology Corp.

Cambridge, MA  
(800) 767-6683  
ontech@on.com  
www.on.com  
CIRCLE 312 ON READER CARD

### Plexcom Inc.

Simi Valley, CA  
(800) PLEXLAN  
sales@plexcom.com  
www.plexcom.com  
CIRCLE 311 ON READER CARD

### Qualcomm Inc.

San Diego, CA  
(800) 238-3672  
www.qualcomm.com  
CIRCLE 310 ON READER CARD

### Quarterdeck Corp.

Santa Monica, CA  
(800) 354-3222  
www.quarterdeck.com  
CIRCLE 309 ON READER CARD

### SBE Inc.

San Ramon, CA  
(510) 355-7650  
allen@sbei.com  
CIRCLE 308 ON READER CARD

### Scitor Corp.

Menlo Park, CA  
(800) 549-9876  
sales@scitor.com  
www.scitor.com  
CIRCLE 307 ON READER CARD

### Softswitch

Wayne, PA  
(610) 640-9600  
www.sedeco.com.ar/softsw/  
softsw.html  
CIRCLE 450 ON READER CARD

### SOS Corp.

New York, NY  
(800) SOS-UNIX  
www.soscorp.com  
CIRCLE 449 ON READER CARD

### Sprint

Westwood, KS  
(800) 829-0965  
www.sprint.com  
CIRCLE 448 ON READER CARD

### Telebit Corp.

Chelmsford, MA  
(800) 989-8888  
info@telebit.com  
www.telebit.com  
CIRCLE 447 ON READER CARD

### TGV Systems Inc.

Santa Cruz, CA  
(800) TGV-3440  
www.tgv.com  
CIRCLE 446 ON READER CARD

### U.S. Robotics Access Corp.

Skokie, IL  
(800) DIAL-USR  
sales@usr.com  
www.usr.com  
CIRCLE 445 ON READER CARD

### Xcellenet Inc.

Atlanta, GA  
(800) 322-3366  
www.xcellenet.com  
CIRCLE 444 ON READER CARD



InfoReports gives you the flexibility you never thought you'd have again.

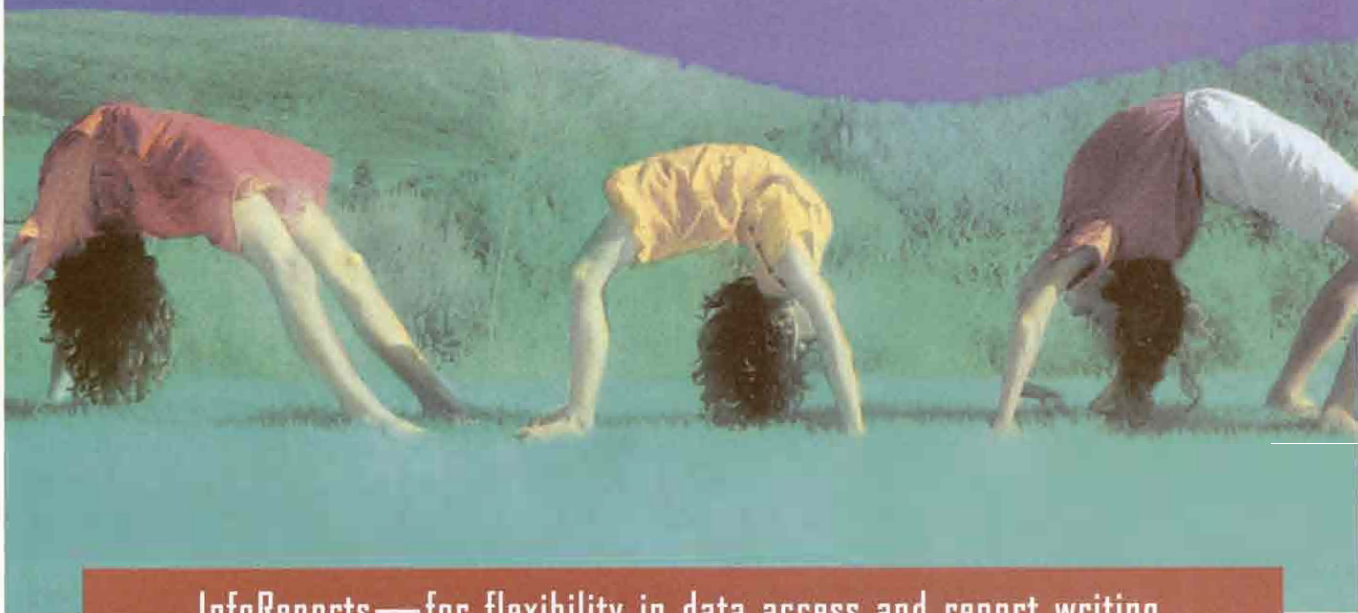

InfoReports—*for flexibility in data access and report writing.*

When it comes to data access and reporting, you don't have to bend over backwards to get the job done. With InfoReports, you can access and combine the data you want from the databases you choose. Run on Windows or Motif, or use a combination. Design on the client, run on the server, and fully support the HP Intelligent Warehouse. Pick and choose data from DB2, Oracle, Sybase, and others to create a single report. No matter how complex your report—whether it's a simple request or involves multiple query reports and complex calculations, you'll find the program stretching with you. InfoReports' flexibility will make you forget you ever had limits—so call today for your **FREE TRIAL** and Business Intelligence Tool Evaluation Guide, and start reveling in the freedom.

**PLATINUM**  
TECHNOLOGY

*The Open Enterprise Management Company*

CIRCLE 199 ON READER CARD

INFOREPORTS

1.800.890.7528 EXT. 3880

info@platinum.com

www.platinum.com

PLATINUM InfoSuite

Query & Reporting

OLAP/Online Analytical Processing

EIS/Enterprise Information System

PLATINUM technology, Inc., 1815 South Meyers Road, Oakbrook Terrace, Illinois 60181. Phone 630.680.3500 Fax 630.693.8719. All product names mentioned are trademarks or registered trademarks of the respective owners and their subsidiaries. PLATINUM technology and the PLATINUM technology logo are registered trademarks of PLATINUM technology, Inc. © 1996 PLATINUM technology, Inc.

**NOW!**  
For Informix®

**“750 untrained users,  
4 operating systems,  
5 platforms,  
10 databases,  
and 1 good thing...**

**...I NEED ONLY ONE SYSTEM TO BACK IT ALL UP!”**



**LEGATO™**

THE NET BENEATH THE NETWORKS™

Facts are, I need backup and restore at up to 100 gigs per hour, *online*, throughout the Enterprise. And because of this cross-platform, multi-OS mess I work in, I need to back-up anything to anything. Plus manage it with no mistakes! Legato's new high-performance backup for Informix, Oracle® and SAP R/3® means I can make my

backup window easily, plus restore data *fast* when my users blow away a table. Even all my GUIs are the same, regardless of the OS or hardware! Plus, I can buy almost any hardware because Legato's Networker® is tape drive independent—it goes fast on anything! And because Legato and HP have strategic partnering arrangements

regarding backup products, I can get technical support for my Networker system from HP as well! Of course, there's NT,™ plus Intranet coming along...Legato's helping me with that, too.

Want automated, seamless backup for your Enterprise? Call 415.812.6000 or email sales@legato.com.



Visit Our  
Web Site at  
[www.legato.com](http://www.legato.com)

CIRCLE 293 ON READER CARD



## In the Mail

Reversing the variables reverses their effect. Complexity in the communications backbone increases the difficulties of interconnecting user agents at the edges, calling for the use of gateways, which can result in distorted messages. This is a big reason why closed, proprietary systems are naturally going by the wayside. As we all have learned the hard way, no message has ever been improved by sending it through a gateway.

The basic simplicity/complexity distinction also partially explains the rise of Simple Mail Transfer Protocol (SMTP) as a standard for Internet mail. SMTP makes no effort to be everything to all people, says Stefferud, but instead allows open extensibility in terms of functional elements.

Stephen Layne, vice president and general manager of the SoftSwitch division of Lotus Corp. (Wayne, Pa.), notes that X.400 services remain a primary requirement for many organizations, especially in government, but that SMTP is being applauded,

"because it promises almost universal connectivity, and means you only need to manage a single infrastructure."

One result is that strictly LAN-based e-mail packages are finding their market niche shrinking, if it hasn't already expired. E-mail packages written to their own proprietary languages sound more simple at face value, rather tempting to the manager of a small or mid-sized organization that doesn't envision *ever* having a need for, say, multimedia messaging, or even Web access. But the complexities avoided with the right Internet-specific package — not even counting scalability — make these products increasingly seem the smarter choice.

Says Nigel Upton, HP's director of worldwide marketing for OpenMail, "No, it's hard to imagine trying to have a discussion of e-mail services without talking about the Internet." It can be done, but it would be ignorant.

Interestingly, SoftSwitch's Layne, in trying to read into the messaging future for Lotus Development and IBM,

envisions messaging and Web protocols eventually becoming integrated, with all client apps enabled for both. The Internet would thus become an even more universal backbone.

"Rather than a one-directional publishing medium, the Web would become a way to carry out business-process applications," Layne says. "Issues confronting administrators as this happens would include accommodating a new generation of 'e-apps' and application frameworks, as formerly standalone applications evolve into client- or server-based applet components. Messaging infrastructure is what provides these capabilities."

Exciting stuff. But, alas, so much for simplicity in *that* vision.

### REPEAT: YOU CAN'T IGNORE THE INTERNET

More and more e-mail vendors are thinking in terms of "intranets" and finding ways to use the openness of

**Workstation**<sup>®</sup>  
**DIRECT**  
YOUR SOURCE FOR MEMORY

**BUY DIRECT  
AND PAY LESS!**

Go direct with a memory manufacturer & with Workstation Direct you pay less than from SUN, HP, SGI and IBM

- ▶ Great Pricing for all your **MEMORY** needs
- ▶ State-of-the-art manufacturing facilities
- ▶ Fully Tested & 100% Compatible
- ▶ Lifetime Warranty
- ▶ FREE Tech Support

Call Toll Free

**888.610.1600**

Offices: Greenwich, CT • Austin, TX • Boulder, CO  
Zurich, Switzerland • Limerick, Ireland

CIRCLE 143 ON READER CARD

In their rush to market  
64-bit systems, our  
competition omitted one  
not-so-minor detail:  
64-bit software.

AS/400 Advanced Series

AS/400<sup>®</sup> Advanced Series gives you 64-bit RISC processing and something HP, Digital and Sun can't match: over 28,000 applications that actually run on it. Right now. The difference? AS/400 is every bit 64-bit: hardware, operating system and software. With no rewriting or recompiling required. To learn more, visit [www.as400.ibm.com](http://www.as400.ibm.com) or call 1 800 IBM-4YOU, Priority Code GAS647.

**IBM**

Solutions for a small planet<sup>™</sup>

IBM and AS/400 are registered trademarks and Solutions for a small planet is a trademark of International Business Machines Corporation. All other company and/or product names are trademarks or registered trademarks of their respective companies. ©1996 IBM Corporation.

CIRCLE 149 ON READER CARD

# Winning the Financial Software Game.

When choosing financial management software, your decision should not be left to chance. You need a system that provides quick access to data, is full-featured and easy-to-use, and has the flexibility to accommodate growth and changes as they occur in your organization. You need Mitchell Humphrey & Co.'s FMS II for all of these winning qualities and more.

## Access To Data

With its advanced array of decision support tools, FMS II allows you to quickly retrieve, analyze and present very large amounts of data. For example, you can easily perform instantaneous drill downs, drill arounds and multilevel consolidations for limitless combinations of data. Or create pie charts, line graphs, correlation graphs, stacked bars and crosstab reports in a matter of minutes. You can even integrate with spreadsheet applications for uploading

budgets and forecasts. What's more, these tools integrate with every FMS II system, including General Ledger, Accounts Payable, Accounts Receivable, Purchasing, Inventory, Project Accounting, Fixed Assets, Consolidations and Budgeting.

## Flexible and Easy-to-use

FMS II provides more flexible features across the board than any other financial management system. These features include customizable screens, menus and on-line help; flexible and powerful budgeting; multiple currencies; consolidations; flexible account number; user-defined data; and comprehensive security.

## Specializing in HP Platforms

FMS II is the only product of its kind that was written from the ground up exclusively for the HP 3000 and

HP 9000—a focus that makes Mitchell Humphrey & Co. an expert in business systems that run on these platforms. FMS II's object-oriented design and layered architecture are also portable across a wide variety of data bases. And since FMS II allows you to use both terminals and PCs, you can meet the special needs of your organization, while minimizing the impact on your budget.

## Winning is easy

Call (800) 237-0028 today to arrange a free demonstration of FMS II. It's a move that will make you a winner in the financial software game.

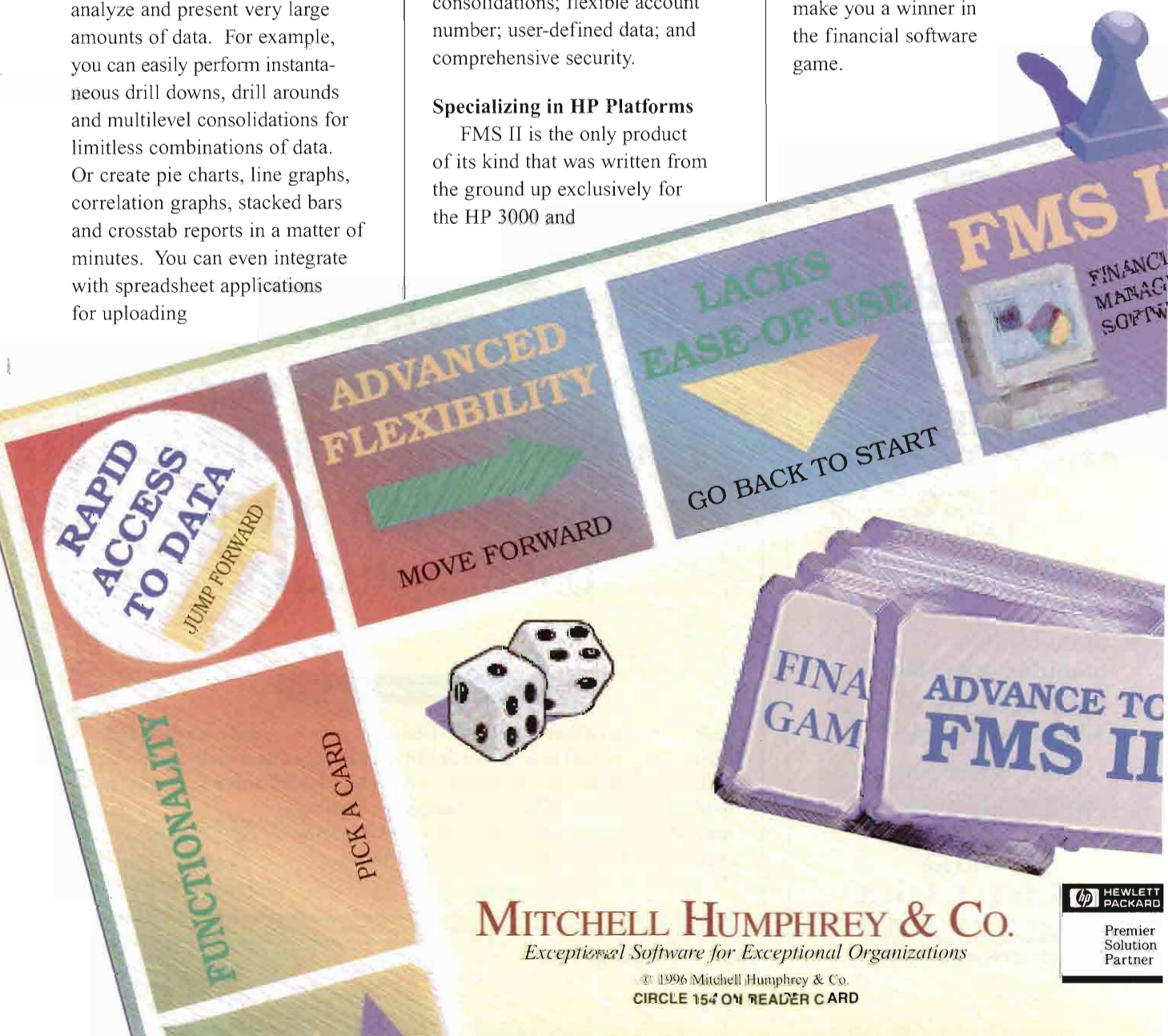

**MITCHELL HUMPHREY & Co.**  
*Exceptional Software for Exceptional Organizations*

© 1996 Mitchell Humphrey & Co.  
CIRCLE 154 ON READER CARD





## In the Mail

Internet protocols to provide efficient messaging within a LAN or small WAN. Don't be too quick to assume that your organization is too small to think in terms of grand messaging schemes. Setting up and running Internet protocols is not necessarily daunting or overly expensive. Think of intranets strictly as a framework, and Internet-based e-mail as an agent. You'll find that thinking of e-mail and the Net together can add cost/value efficiency while keeping open any messaging migration path you may have.

### WHO'S OPENING THE MAIL?

HP released its OpenMail product for Windows NT this summer, allowing OpenMail on NT to integrate with other OpenMail servers on HP-UX, Solaris, IBM AIX and SCO UNIX platforms. Lotus cc:Mail and Microsoft

Mail clients are supported, and HP has plans to use Microsoft API 1.0, providing full support for the Microsoft Exchange Client unveiled in April.



Says HP's Upton with some degree of excitement, "Getting into the NT market with e-mail of course gets us into a tiny scrap with Microsoft." But most industry analysts feel this is not necessarily true, that there is enough interest in Windows NT migration for each to be able to farm their own installed base.

General Manager of HP's Enterprise Messaging Operation (EMO) Korak Mitra says the increased customer

interest in Windows NT as a work-group or departmental server was not the only reason for bringing OpenMail to Windows NT.

"We are also responding to Microsoft Mail customers who want more robust, enterprisewide solutions which don't dictate either the hardware server or operating system," Mitra says. "OpenMail on Windows NT will provide full messaging capabilities across UNIX and NT environments while supporting a variety of desktop platforms. It doesn't require a commitment to a Windows NT-only server environment."

Installed on 2 million seats worldwide, HP OpenMail on UNIX already supports Microsoft Exchange clients through MAPI 1.0. A client-server approach to groupware, based on an X.400 backbone, OpenMail is part of Internet Collaboration Services from HP, which incorporates the use of

## THE TOTAL SOLUTION

*sales, service, support*

◀ On-time service, on-line equipment.

Black River takes the risk and worry out of ordering, implementation and maintenance.

You're assured:

■ Full line of new and previously owned, refurbished 9000, 3000 and 1000.

■ Technically trained maintenance team.

■ Free installation

■ Nationwide service.

Call 216-365-9950 or fax 216-365-3916 for more information.

**BLACK RIVER**  
COMPUTERS

THE TOTAL SOLUTION  
*sales, service, support*

7630 RACE ROAD • NORTH RIDGEVILLE, OHIO 44039  
216-365-9950

# The Web without the wait.

AS/400 Advanced Series

Now you can quickly transform your AS/400® into a Web server. Create a home page. Develop new Web applications. Even automatically Web-enable over 25,000 AS/400 applications. On the fly. Without having to rewrite software or retrain staff. (No one else can make this promise.) To get started, visit our Web site at [www.as400.ibm.com/connect](http://www.as400.ibm.com/connect) or call 1 800 IBM-4YOU, Priority Code GAS6B00L.

**IBM**

Solutions for a small planet™

IBM and AS/400 are registered trademarks and Solutions for a small planet is a trademark of International Business Machines Corporation. © 1996 IBM Corporation.

CIRCLE 171 ON READER CARD

CIRCLE 474 ON READER CARD

## In the Mail

Internet protocols such as SMTP, NNTP, HTML, POP3 and IMAP4. With the stress on an Internet-based architecture, HP has developed the "universal in-box," in which a user receives all incoming voice and electronic mail, including applications messaging.

A key first step toward readying OpenMail's repertoire for the Internet

came last fall when HP integrated it with OpenView for centralized management. According to Mitra, OpenView's management-by-exception approach allows network administrators to detect a problem on a remote OpenMail server, and initiate a predefined action to resolve the problem. Likewise, configuration of OpenMail

users is simplified by letting an administrator drag-and-drop an icon between two servers.

Security for OpenMail is embedded into the messaging architecture through a public key encryption infrastructure that is based on Nortel's (Mississauga, Ontario) Entrust, and includes transparent client-level encryption and digital signaturing.

To solidify its latest "messaging" message, if you will, HP signed a comprehensive agreement with Netscape (Mountain View, Calif.) in May that includes everything from sales and marketing, to reselling Netscape SuiteSpot and Fast Track server software for HP-UX and Windows NT servers. Interoperable messaging between OpenMail and Netscape Mail Server is another step toward the vision of workforce collaboration through intranets.

Says HP's Upton, "Inside HP, for example, I don't think you'd find that people live inside Netscape [Navigator]. But we know that there's more to the Internet than just publishing Web pages."

This is the key thought behind HP's new messaging vision, and it's not surprising because, as Netscape CEO Jim Barksdale noted at the time of the agreement, HP is the owner and operator of the world's largest intranet using Netscape software.

### THROUGH STATIC ON THE NET

HP is by no means the only organization that recognizes the rise of the Internet when it comes to e-mail and overall messaging. April's E-Mail World trade show in Santa Clara, Calif. was a launch pad for a number of new broader, Internet-based strategies from large e-mail vendors.

For example, Qualcomm (San Diego, Calif.) announced the opening of a storefront on Marketplace MCI, and a three-tiered strategy that begins with a focus on the Internet consumer market. There are about 10 million worldwide users of Qualcomm Eudora according to Matrix Information Directory Services (Austin, Texas), a

*Thanks to Harmonizer, over 3000 Aldon customers are humming a new tune about installing new packaged software releases.*

# A classic from the Aldon repertoire. Harmonizer.

Harmonizer allows you to make modifications to your software applications and still take advantage of new releases.

In fact, Harmonizer can save you 60-80% of the time you now spend putting up new releases.

Harmonizer identifies and reports all changes made by you and by the vendor on a new release, then merges your changes with the new release to create new production versions of your programs. It's that simple.



 **ALDON**<sup>®</sup>  
The Art of Change Management

**Aldon Computer Group**  
401 15th Street  
Oakland, California 94612  
(510) 839-3535  
(800) 825-5858  
FAX: (510) 839-2894

And the elegant Harmonizer user interface makes it easy to learn and use.

Conduct your own examination —for a free software trial, call toll free, 1-800-825-5858.

CIRCLE 163 ON READER CARD



company studying Internet growth, which places Qualcomm among other leading Internet-based packages.

Qualcomm's open-ended solution supports POP3, SMTP and MIME, making it a truly Internet-specific package, and the company added MAPI and Windows 95 support to Eudora last winter. Eudora doesn't route mail to online services such as CompuServe and America Online automatically, so you don't get the "universal in-box" effect. But it does boast Windows NT support, as well as a nifty "active URL" feature that lets the user click on a URL within the e-mail message and link directly to a specific Web site.

Using such "active e-mail" features can crystallize the notion of where messaging is headed, and what role e-mail will play in it. Everyone remembers their first e-mail, because more than anything, it crystallized for them the concept of being on a computer network.

I recall the feeling of entering a new

era that came with sending my first e-mail message at Carnegie Mellon University in 1986, on a pioneering system called Andrew, whose chief designer was Nathaniel Bornstein. Bornstein, another primary author of the MIME standard protocol, has been pushing active messaging since well before the recent rise in Web popularity. He has always believed e-mail could be more than a passive, one-way mechanism, and that vision originally had little or nothing to do with the Web.

"Active messaging extends the capability of e-mail to the automation of computer-supported cooperative tasks, allowing it to replace or augment an ever-larger portion of more routine business events and paperwork, as well as providing Web access," says Bornstein.

If you're an administrator of a small-to medium-sized network, all the talk about advanced messaging and forming intranets may sound daunting — expansive and expensive. In truth, it

doesn't necessarily have to be either. As usual, the best advice is to know exactly what your organization may need, now and in the future, and then do some careful shopping, because there are a ton of options. But keep in mind that Internet-access boxes are not that expensive, and almost all include some e-mail application. Even if you don't feel the need for the larger, Internet-based e-mail apps that serve as complete messaging solutions, it is easy enough to set up your network to retain options.

Don't ignore Net connections because you may think e-mail is all you'll ever need internally. With the right choice of Internet access solutions, you can position yourself to someday reap the benefits of advanced messaging that are already on the way.

— Barry Slawter is a freelance journalist who specializes in networking and communication issues.

Would you like to continue to see articles on this topic?  
Circle on reader card yes 348 no 347

## WE DON'T MAKE REPORTS. WE MAKE THEM APPEAR WHEN AND WHERE THEY ARE NEEDED . . . FAST!

ON USERS PCs OR NETWORK PRINTERS.

 **REVEAL/CS™ DELIVERS THE REPORTS USERS NEED, WHEN AND WHERE THEY NEED THEM.** ACCORDING TO FORTUNE 500 FINANCIAL CORPORATION, "REVEAL/CS PROVIDES A MORE FUNCTIONAL WAY FOR USERS TO VIEW REPORTS." NOT ONLY DOES REVEAL/CS ALLOW ON-LINE VIEWING; BUT IT ALSO PROVIDES AUTOMATIC REPORT DISTRIBUTION TO NETWORK PRINTERS.

 **WITH THE POWERFUL WINDOWS® INTERFACE OF REVEAL/CS, USERS CAN INSTANTLY AND SIMULTANEOUSLY ACCESS SEVERAL CORPORATE REPORTS LOCATED ON DIFFERENT SERVERS. NO MORE PAPER CUTTING, BURSTING, SHIPPING, PILING AND DISPOSING. CUT PAPER COST. CUT DISTRIBUTION TIME. CUT SUPPORT COSTS.**

 **THE UNIQUE PINPOINT DISTRIBUTION™ AND SECURITY ENGINE OF REVEAL/CS AUTOMATICALLY TARGETS THE DELIVERY OF REPORTS TO THE RELEVANT USERS OR DIRECTLY TO NETWORK PRINTERS.**

**PAGE-LEVEL SECURITY ENSURES THAT QUALIFIED STAFF WILL REVIEW ONLY APPROPRIATE INFORMATION.**

 **USERS CAN GRAPHICALLY EXTRACT THE DATA THEY NEED FROM LARGE REPORTS AND CREATE SUB-REPORTS SPECIFIC TO THEIR NEEDS. REPORTS AND SUB-REPORTS CAN THEN BE EXPORTED PRONTO TO SPREADSHEETS.**

 **ACT NOW TO MAKE REPORTS APPEAR ON YOUR USERS' DESKS . . . FAST! CALL THE COMPANY THAT INVENTED ON-LINE VIEWING IN THE HEWLETT-PACKARD WORLD AND SEE FOR YOURSELF HOW EFFICIENT REVEAL/CS IS ON THE HP9000, THE HP3000 AND THE RS/6000.**

 **FOR A FREE 90-DAY REVEAL ROADMAP TO SUCCESS DEMO, PLEASE CALL O'PIN SYSTEMS NOW AT (612) 883-2888 AND ASK FOR ONE OF OUR REPORT DISTRIBUTION CONSULTANTS.**

 **O'PIN SYSTEMS**

INTERNATIONAL PLAZA, SUITE 635 • 7900 INTERNATIONAL DRIVE  
BLOOMINGTON, MN 55425-1510  
[HTTP://WWW.OPIN.COM](http://www.opin.com)

CIRCLE 258 ON READER CARD

# How to Win the EDI Integration Race.



## Ready ...

It takes the right software and lots of industry experience to integrate EDI data into your business applications. Trinary Systems is the right choice. Our electronic commerce products and integration services have helped many leading companies successfully merge EDI operations and data into existing business systems.

## Set ...

Trinary Systems will manage your EDI implementation or train your staff to integrate **EDI WINDOWS™** with your application software to meet business requirements. Our project teams are experts at automating the flow of EDI data in and out of business applications. And we complete implementation projects on time and within budget.

**BPIs™** (Business Process Interfaces) are available for application software vendors such as SAP, QAD, Oracle and others. We have earned the highest levels of certification for data integration with these software packages.

## Go!

If you are looking for an EDI software vendor that's setting the pace in integration products and services, give us a call at

**1-800-377-9120**

**1-810-442-9125 FAX**

**trinary  systems**  
inc.

UNIX VMS MPE/iX  
Windows NT available now!

CIRCLE 223 ON READER CARD



# EDI & The Internet... Right Now

## The Internet Provides A Flexible Platform For Communications, Alliances And Business-to- Business Collaborations

**T**oday, thousands of firms use the Internet. By the turn of the century, this number is expected to increase to hundreds of thousands — and possibly, a million. While most are attracted by the promise of global sales and “cyber-cash,” the big winners are, and will continue to be, the companies that use the Internet for electronic collaboration and electronic data interchange (EDI).

Despite 15 years of government and industry advocacy, EDI hasn't grown as rapidly as projected because of the high cost and the dedicated, proprietary value-added networks (VANs) required. However, companies are quickly finding that the Internet is an excellent, cost-effective vehicle for information distribution and business-to-business interactions.

Firms are attracted to Internet EDI because it helps them improve the quality and timeliness of information exchange, improve productivity, enhance data accuracy, reduce costs, promote trading partner loyalty and

improve inventory management. It also reduces the use of paper as well as paper storage requirements.

While the benefits of handling the exchange of information electronically are overwhelming for firms of all sizes, the missing ingredient has been fast, easy and secure interfaces between application-to-application and user-to-application efforts. Recent software introductions make it possible to

avoid VANs, while providing a direct-connect EDI so that documents and data can be exchanged anywhere in the world over the Internet.

The key for an economical implementation of Internet EDI is to establish EDI standards between trading partners so that documents and data can be securely transmitted and authorized by the system's translator.

### PIGGYBACK EDI

One of the key benefits of Internet EDI is it allows organizations to piggyback EDI onto their existing network, rather than having to use VAN networks. In addition, because the

Pushpendra Mohita

Internet is truly a global network, it expands the universe of business trading partners to literally all businesses on the Net.



# Get a Life.

## Do You Ever Feel Your Life Doesn't Exist Outside of Work?

Does poor response time turn your weekends into workdays? Would a Saturday or Sunday without reloading your disk drives be a miracle? Too bad. Life doesn't have to be that way.

Getting control over your operating environment is no easy task. But with the help of **Disk Space Manager**, the job gets a whole lot easier. With this powerful tool at your fingertips, you'll soon be spending more time juggling your social calendar and less time juggling your disk space.

**Disk Space Manager** is a multi-purpose tool that allows you to manage

your disk environment easily and efficiently, gaining substantial new space without the expense of additional hardware. It runs online, without operator intervention, and uses HP's Transaction Manager (XM) to protect data integrity.

Using features like truncation, defragmentation, spreading and combining of files, populate set and manage set, you'll soon be managing your disk environment effortlessly—and you'll be assured of top I/O performance. It's that simple... No juggling. No worries. No weekend interruptions.

**Get Your Life Back.  
Get Disk Space Manager.**

**For Free Demo,  
Call 1/800/294-1150**



# DISKSPACE MANAGER

A Bradmark Solution

Disk Space Manager is a copyright of SolutionSoft Systems. All rights reserved, 1996.

CIRCLE 108 ON READER CARD



## EDI & The Internet

While secure consumer-to-business Internet transactions provide visions of national and international sales, it is the more mundane business-to-business applications that will have the largest

impact on corporate bottom lines. The Gartner Group (Stamford, Conn.), a research firm, predicts that the introduction of Internet EDI solutions will dominate the high-volume exchange of documents, data and information between businesses and multiple trading partners.

According to Len Keeler, author of *CyberMarketing*, private networks, by their very nature and structure, limit the number of firms a single company can reach and interact with, while Internet EDI permits firms to add and subtract partners in real-time. Businesses can offer product informa-

*The following EDI Conferences and Seminars are sponsored by Data Interchange Standards Association (DISA) and EDI World. For more information on DISA, including locations of Trimester meetings, call (703) 548-7005.*

- **SEPTEMBER 26-28, 1996**  
**Perception to Implementation**  
Newark, NJ  
DISA
- **SEPTEMBER 29, 1996**  
**Fundamentals of EDI**  
Miami, FL  
DISA
- **SEPTEMBER 29-  
OCTOBER 4, 1996**  
**X12 Trimester Meetings**  
Miami, FL  
DISA
- **OCTOBER 1-4, 1996**  
**X12 Trimester Meeting**  
DISA
- **OCTOBER 24-26, 1996**  
**Perception to Implementation**  
Chicago, IL  
DISA
- **NOVEMBER 14-16, 1996**  
**Perception to Implementation**  
Nashville, TN  
DISA
- **DECEMBER 5-7, 1996**  
**Perception to Implementation**  
Washington, D.C.  
DISA
- **FEBRUARY 2-7, 1997**  
**X12 Trimester Meeting**  
DISA

**PRODUCTS** that work  
& **People You Can Work With**

**EC/EDI Solutions** .....

Powerful Translation  
GUI Visual Mapping  
Flexible Scheduling  
EDI Service Bureau  
Application Integration  
Internet to EDI

WWW <http://www.spedi.com>  
Email [info@spedi.com](mailto:info@spedi.com)

**ST. PAUL SOFTWARE**  
1450 ENERGY PARK DRIVE, ST. PAUL, MN 55108  
TEL 612/603-4400 FAX 612/603-4403  
SALES 800/998-4EDI (4334)

Unix, Midrange, Mainframe, PC

CIRCLE 237 ON READER CARD

## EDI & The Internet

tion online that virtually never goes out-of-date, and it is available to any firm with access in over 137 countries.

### VIRTUAL PRIVATE NETWORKS

Rather than global any-to-any “drop-in” commerce, Keeler sees a rapid implementation of virtual private networks using the Internet which will permit organizations to carry on secure and reliable information exchange with authorized members of the network. These networks can connect any member of the corporation’s community, including preferred customers and suppliers. All the firm needs is to establish a secure platform, provide certification authority for users and secured applications to members of the virtual private network.

Firms find that they can establish their virtual EDI networks without lengthy and expensive setup procedures. Instead, they only need to agree on the information needs, business procedures and technical arrangements. New business partners can be added or deleted. Almost immediately, organizations can provide requests for quotes (RFQs) and ordering information simply by using translation software.

Recent recommendations from the Internet Engineering Task Force (IETF) have established recommendations for encapsulating EDI objects within Multipurpose Internet Mail

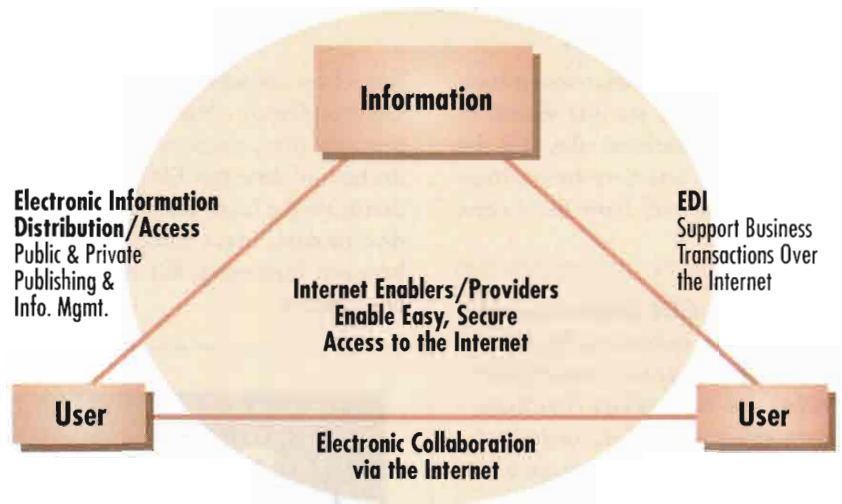

Figure 1: Today, companies find the Internet offers the media for electronic collaboration, information distribution and business-to-business interactions.

Extensions (MIME), so EDI transactions can be handled through Internet e-mail. New capabilities are available which permit firms to provide address authentication, data integrity, privacy/confidentiality/access control and non-repudiation. This permits forms to be filled out online and submitted for immediate processing. For business transactions, ordering, shipping and billing information can be safely encrypted for protection against alteration or replacement.

Whether organizations implement

virtual private networks on the Internet or use the Internet for collaborative work and development, the EDI capabilities of the Internet provide

**The establishment of a virtual Internet EDI network can be 90 percent less expensive than a VAN.**

— BIS Strategic Decisions (Stamford, Conn.)

the potential for far greater returns than electronic commerce, which will ultimately permit consumers to purchase products online.

Internet EDI represents a ready-made platform for reducing their procurement cycles, strengthening relationships with customers and suppliers, and establishing flexible alliances with individuals and organizations.

Operational efficiencies will be produced by replacing paper-based business forms such as purchase orders, invoices and shipping slips. Organizations ranging from government agencies to retailers and healthcare suppliers can establish transaction sets that will enhance their ability to provide electronic business documents with trading partners — at a fraction of the cost and with improved accuracy.

—Pushpendra Mohta is chief technology officer at California Education & Research Federation Network (CERFnet; San Diego, Calif.). He can be reached at [pushp@cerf.net](mailto:pushp@cerf.net).



Figure 2.



# 3

## Ways to be a better host

### 1 *DataExpress*<sup>™</sup>

If your end users can't reach the data they need then treat them to DataExpress. Deliver host based data in PC file formats such as Excel, Lotus and Word Perfect Merge File. DataExpress can access Turbolmage, Allbase and Oracle databases. Interfaces are available for PowerHouse<sup>®</sup> PDL/QSCHEMAC and OMNIDEX either directly or via the TPI interface. End user and production reporting were never so easy.

### 2 *ODBCLink*<sup>™</sup>

As an option to DataExpress, ODBCLink greatly enhances desktop access, by providing support for ODBC enabled applications such as Impromptu, MSAccess, Excel, and Visual Basic to name a few. In addition ODBCLink will provide access via a serial/modem connection or via Winsock. ODBCLink can access PowerHouse PDL dictionaries, Turbolmage, Allbase, Oracle, KSAM and MPE files. If you are a Omnidex or Superdex site you will be pleased to know that ODBCLink provides access to the TPI interface. ODBCLink is available in both 16 and 32-bit.

### 3 *EDI Windows*<sup>™</sup>

Electronic Data Interchange (EDI) is bringing true automated efficiency to everyday task formerly done by hand. Successful businesses from all industries world wide are embracing EDI. *EDI Windows* enables the link from your HP3000, HP9000, DEC VAX, RS6000 and WindowsNT platforms, to those all important customers and suppliers, for purchase orders, quotations, invoices and much more.



**M. B. Foster  
Associates Limited**

*Your Integration Software Supplier*<sup>®</sup>

1-800-ANSWERS (267-9377)

Phone: (613) 448-2333

Fax: (613) 448-2588

82 Main Street South, Chesterville,  
Ontario, K0C 1H0

No More Excuses!  
Visit Us Today.

<http://www.hppro.com>

Bookmark it.

**HP** Professionals



# A

# White Paper:

## Building Client-Server Applications On The HP 3000

### PART 2

► *By Rohan Hall*

*Editor's Note: Last month, Part 1 of Building Client-Server Applications On The HP 3000 introduced the "notion" of client-server on the HP 3000 by explaining the elements of the Server as well as defining the terminology of Client-Server computing. This month, Part 2 offers a look at the Client including hardware, programming software and networking requirements.*

#### WOULD YOU BELIEVE...

The controller looked at the cash flow summary. She had clicked the new button that was added to her Microsoft Excel application. She compared the retrieved data on her spreadsheet with the report she got this morning. The numbers were different. She studied it a little closer before it occurred to her what had happened. It was 9:45 a.m. Cash had posted at 9:30 a.m. What she was looking at on her spreadsheet was live data from her HP 3000 system. The other report showed data as of the end of yesterday. This new application was showing her real-time information.

She could get to like this new client-server application...

#### THE CLIENT

The client's main responsibility is to provide a friendly user interface that facilitates

the way data is requested from the server and presented to the user. Based on the current technology, this requirement can sometimes be a challenge to achieve. The main technology involved in fulfilling the client requirements are the hardware, programming language and middleware.

#### ► *The Hardware*

The client hardware is typically a Microsoft Windows-based PC. This PC should be outfitted with a lot of memory (RAM), as well as a powerful processor. A 486 with 8 MB of RAM is the minimum requirement. The disk space requirements will depend on the

size and responsibilities of the client application.

The client hardware is important in a client-server application, because the nature of a client-server relationship suggests distributed processing. This means that the server and the client may share the responsibility for processing data. The client's responsibility to process this data may include sorting returned data, processing complex calculations, communicating with other client tools, manipulating graphics or many other functions. If the client is not sufficiently powerful, it can create a bottleneck in the flow of data.

#### ► *The Programming Language*

Fortunately, most client languages are visual versions of traditional languages. These languages were redesigned to operate in a graphical user environment, and are event driven versus menu driven. These languages use an object-oriented programming (OOP) concept where an event (i.e., a mouse click) that is performed against an

object (i.e., an icon) determines what code to execute.

Behind objects, however, the code is basically the same as traditional languages on any platform. Visual Basic (VB) executes Basic, Axient executes Powerhouse, C++ executes C, and Delphi executes Pascal. There are slight differences and additional capabilities for each object-oriented language, but the general syntax is very similar.

The challenge that an HP 3000 environment faces with these languages is the new programming concepts that they introduce. A Cobol programmer who has to write Powerhouse code on an HP 3000 for the first time will have a learning curve: there are no DB calls to be made, they wonder how the database is opened, how the datasets are linked, what does an "Access" statement really do, and how can they

be sure the data was updated? This programmer would also have a learning curve with object programming. How does a mouse click execute code, how can they open an IMAGE database from a PC, how is data displayed in the various objects available?

It is important, therefore, to pick a language that can be leveraged. VB is currently one of the most popular choices for client-server development. It is a very powerful and flexible language with virtually unlimited capabilities via add-on products in the form of VBXs, Dynamic Link Libraries (DLLs) and other Windows-based technology. Most programmers have a Basic background, and therefore find it to be an easy product to learn.

VB also has some of the most advanced and easy to use debugging features currently on the market. These debugging features consistently prove themselves to be invaluable in this type of application development. Furthermore, because all future Microsoft products will have VB as its common programming language or script, VB appears to be one of the better choices for client development.

**➤ The Middleware**

Middleware is a vague term that describes applications that sit somewhere between the client and the server. Specific to this article, however, middleware will refer to DLLs that facilitate the communication between the client and the server.

DLLs refer to libraries of routines that are commonplace in the Windows environment. These DLLs are similar to XLs on HP 3000 systems. An XL can be used to enhance the capabilities of a language when it is linked into or referenced by that program. Similarly, a DLL enhances capabilities of the program that reference that DLL.

The routines in the DLLs are called Application Programming Interfaces (APIs). These APIs, when called, perform a variety of functions that would normally be outside the scope of the programming language. These functions could include playing music, creating animation, linking computers or a variety of other tasks.

# Do You Have One UPS, A Bunch Of UNIX Servers, And A Burning Desire For Advanced Power Management?

## Looking to Avoid Buying Multiple UPS's for Multiple Servers?

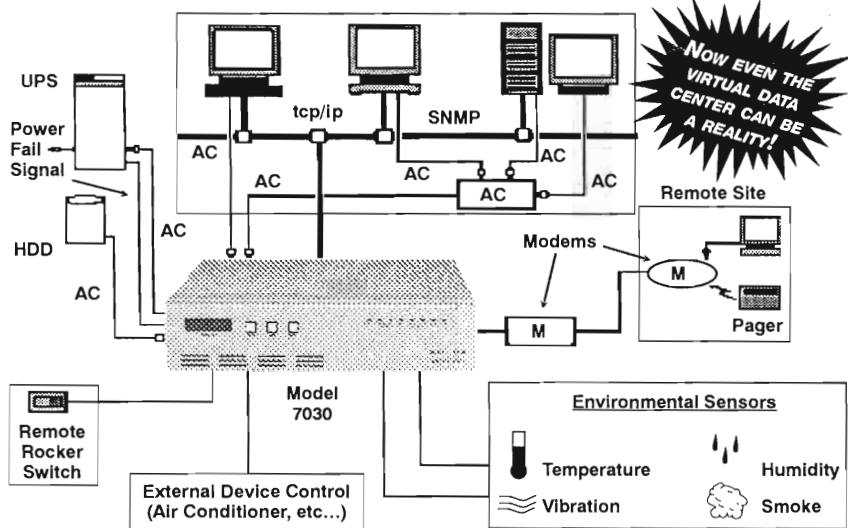

**NOW EVEN THE VIRTUAL DATA CENTER CAN BE A REALITY!**

## Save Money With Texas ISA's Ultimate UNIX Power Management Solution!

**FEATURES**

- ◆ Automatically applies and removes AC power to networked computers and peripherals using one UPS
- ◆ Gracefully shuts down and starts up computers using:
  - ◇ Attached Rocker Switch
  - ◇ Programmable Timers
  - ◇ Environmental Sensors
  - ◇ UPS Power Fail Signal
  - ◇ Local or Remote Console
- ◆ Connects through serial or LAN port
- ◆ Notifies remote system or pager of abnormal conditions
- ◆ Digital inputs and outputs to monitor external devices
- ◆ Supports TCP/IP and SNMP

**BENEFITS**

- ★ Protects the OS and data from being corrupted
- ★ Increases computer and peripheral life expectancy
- ★ Helps UNIX managers conform to the EPA Energy Star program
- ★ Secures the startup/shutdown procedure against unauthorized access
- ★ Eases local and remote systems management
- ★ Eliminates unnecessary travel time to reboot remote systems
- ★ Facilitates large scale distributed computing power-downs and power-ups
- ★ Makes the virtual data center a reality

**Call Texas ISA today for your FREE 30 day trial. It's simple to install.**

**800-361-2258 • 713-493-9925**

**info@texasisa.com • Website: <http://www.texasisa.com>**



# READER INFORMATION

## CONCORDE TECHNOLOGIES

### Circle 232

Concorde Technologies, Inc., "The Hewlett-Packard Experts" is an HP Channel Partner and Value Added Reseller of HP and third-party products for the HP 9000. Concorde's line of products includes HP 9000 systems, application software, CD-ROM solutions, RAM memory, mass storage peripherals and accessories. For the best prices, availability, warranty and support,

**Concorde Technologies.**

Call (800) 359-0282

E-mail: [info@concordetech.com](mailto:info@concordetech.com)

<http://www.concordetech.com>

## IEM CO.

### Circle 122

IEM offers affordable solutions for the HP environment, including 4mm and 8mm tape drives, autoteaders and carousels, QIC tape drives, optical drives, fixed winchester drives, floppy disk drives and combination drives. IEM's new Building Block product line is a modular storage solution into which you can slide a number of different disk, tape and optical units. IEM offers an automated backup and archival software solution. Most IEM products are available with an HP-IB or SCSI interface for HP 1000, 3000 and 9000 computers.

Call (970) 221-3005 or (800) 321-4671,

or send E-mail to [info@iem.com](mailto:info@iem.com).

## INFORMATION BUILDERS INC.

### Circle 247

Information Builders provides FOCUS, the world's most widely used 4GL, and EDA/SQL, the number one rated middleware solution. Available on HP-UX, MPE/iX and 35 other platforms. FOCUS is used for application development and decision support. EDA/SQL is used for data access, warehousing, migration and much more.

Call (800) 969-INFO.

## M.B. FOSTER ASSOCIATES LTD.

### Circle 155

DataExpress, the #1 End-User Computing Environment and report writer. EDI Windows, translation software. Reflection and the Network Series.

Call (800) ANSWERS,

FAX (613) 448-2588.

## NEWPORT DIGITAL CORP.

### Circle 246

Accelerator cards for HP 9000 Series 200 plus HP 310 and HP 320. Ten-fold performance improvement.

Call (714) 730-3644.

## SOFTWARE LICENSING CORP.

### Circle 123

Located at 930 Tahoe Blvd., Unit 802, Incline Village, NV 89454-9436.

Call (800) 831-0882 or (702) 832-0861.

<http://www.slcorp.com>

## TEXAS ISA INC.

### Circle 127

HP-IB and SCSI Tape and Disk Storage • Data Buffers • Power Management Solutions for UNIX and non-UNIX Platforms. Manufacturers of storage solutions for HP environment for 15 years. With our unique new line of Intelligent Automatic Startup and Shutdown devices, companies can now control the AC power ON/OFF schedules of local and remote UNIX systems. The ISA 7030, for instance, can warn of abnormal environmental conditions (temperature, vibration, humidity and smoke), and perform graceful shutdowns and startups. These new devices can significantly enhance system and data security, save time, energy and equipment costs. They also tremendously increase the convenience of managing local and remote systems.

For more information visit us on the

World Wide Web: <http://www.texasisa.com>,

E-mail: [info@texasisa.com](mailto:info@texasisa.com), or

call (713) 493-5746, (800) 361-2258.

## QUEST SOFTWARE

### Circle 269

The only complete HP 3000 solution for:

- 1) High speed network file and database access.
- 2) IMAGE, KSAM and MPE file shadowing.
- 3) Low overhead and network spooling.

Call (714) 720-1434.

## WRQ

### Circle 263

Makers of Reflection Series Software. HP terminal emulation for PCs and Macintoshes.

Call (800) 872-2829.

# ADVERTISER INDEX

Reader Service Number	Page
163	Aldon Computer Group . . . . .30
386	Andataco Computer Peripherals . . . . .5
241	ATL Products . . . . .22
497	Attachmate Corp. . . . .19
181	Aurora Software Inc. . . . .11
194	Bering Technology Inc. . . . .11
171	Black River Computers . . . . .29
108	Bradmark Technologies Inc. . . . .34
232	Concorde Technologies . . . . .C2
213	CSU Industries . . . . .42
271	DECUS . . . . .50
296	EMASS Inc . . . . .1
197	FSA Corp. . . . .45
166	G.E. Capital . . . . .21
198	GEJAC Inc. . . . .42
149	IBM AS/400 Direct Division . . . . .27
474	IBM AS/400 Direct Division . . . . .29
122	IEM Inc. . . . .2
247	Information Builders Inc. . . . .9
218	Insignia Solutions . . . . .17
293	Legato Systems Inc. . . . .26
155	M.B. Foster Associates . . . . .37
154	Mitchell Humphrey & Co. . . . .28
246	Newport Digital Corp. . . . .6
258	O'PIN Systems . . . . .31
199	PLATINUM Technology Inc. . . . .25
200	Polaris Service Inc. . . . .43
269	Quest Software . . . . .C3
237	St. Paul Software . . . . .35
165	SunGard Recovery Services Inc. . . . .13
127	Texas ISA Inc. . . . .40
223	Trinary Systems Inc. . . . .32
266	Technical & Scientific Application (TSA) . . . . .51
143	Workstation Direct . . . . .27
253	Workstation Solutions . . . . .4
	WRQ . . . . .C4
115	Xerox Corp. . . . .15

## ADVERTISING SALES OFFICES

Leslie Ringe, Publisher • (215) 643-8070

### EAST COAST

(215) 643-8070

Leslie Ringe

Regional Sales Manager

1300 Virginia Drive, Suite 400

Fort Washington, PA 19034

FAX (215) 643-8099

[ringele@cardinal.com](mailto:ringele@cardinal.com)

### MIDWEST/SOUTH CENTRAL

(215) 643-8063

Gloria Goodwin

Regional Sales Manager

1300 Virginia Drive, Suite 400

Fort Washington, PA 19034

FAX (215) 643-2143

[goodwingm@cardinal.com](mailto:goodwingm@cardinal.com)

### NORTHWEST/SOUTHWEST

(510) 595-2140

Luisa Peticucci

Regional Sales Manager

6400 Hollis Street #4

Emeryville, CA 94608

[peticucci@cardinal.com](mailto:peticucci@cardinal.com)

FAX (510) 595-2148

### EUROPE

33 42 92 24 85

Fran Grega

European Sales Manager

1220 Chemin des Platrieres

13090 Aix-en-Provence

France

FAX 33 42 92 24 67

[103002.363@compuserve.com](mailto:103002.363@compuserve.com)

### Cheryl DeMaioribus

Marketing Services Manager

(215) 643-8108

[demaiorici@cardinal.com](mailto:demaiorici@cardinal.com)

### Cathy Dodies

List Rental Manager

(215) 643-8047

[dodiescl@cardinal.com](mailto:dodiescl@cardinal.com)

### Lisa Merck

Product Showcase Sales Manager

Card Deck Manager

(630) 655-0100

FAX (630) 655-0755

[merck@cardinal.com](mailto:merck@cardinal.com)

1300 Virginia Dr., Ste. 400  
Fort Washington, PA 19034  
(215) 643-8000 FAX (215) 643-8099

(215) 643-8000 • FAX (215) 643-8099

The DLLs of interest are those that allow communication between the client PC and the server HP 3000. These DLLs are provided by various HP 3000 vendors and allow a network, serial or modem connection from the client to the server. Each uses its own methodology to access the server. Depending on the project, these DLLs could be the determining factor regarding a successful or unsuccessful implementation.

**► Networks and Communications**

Thanks to the introduction of ARPA as a standard part of the software shipped with the HP 3000 system (as of version 5.0), the communication piece of this equation has shifted from being very complex to relatively easy. The two main ways that the client-server communication is established is via TCP/IP or a serial connection.

**TCP/IP** — The Department of Defense (DoD) Advanced Research Projects Agency (ARPA) devised the

concept of sending data via packets (pieces at a time) between computers. These packets contain both data and addressing information (IP address), and are sent across regular telephone

Today, however, HP has included ARPA, and therefore TCP/IP, as a standard part of their operating system.

The benefit of TCP/IP is having a global standard of network communi-

## Until MPE/iX version 5.0, ARPA services were not a standard part of the HP 3000 operating system.

wires using a standard protocol they developed called TCP/IP (Transmission Control Protocol/Internet Protocol). Each computer system that has this TCP/IP software is able to communicate with one another, regardless of the platform. Some features of ARPA services include ftp (File Transfer Protocol), telnet and TCP/IP.

Until version 5.0, ARPA services were not a standard part of the HP 3000 operating systems. Prior to then, it was necessary to upgrade and install system patches to obtain this feature.

The greatest example of this is the Internet. The Internet allows the linkage of computers all over the world using TCP/IP and other standard network protocols.

When TCP/IP is used to communicate between computers, an IP address is used to uniquely identify each computer. This same IP address is used by the client to connect to the server. The IP address can be thought of as a street address that identifies the location of a computer on the network.

TCP/IP, therefore, is the recom-

### Resource Accounting Solution for UNIX, NT and Open VMS

#### ARSAP Offers:

- Resource Management
- Oracle Accounting
- Project Accounting
- Software Package Usage
- Capacity Reporting
- Cost Recovery / Chargeback
- Advanced Presentation Graphics
- Easy to Use GUI
- Enterprise-wide Reporting!

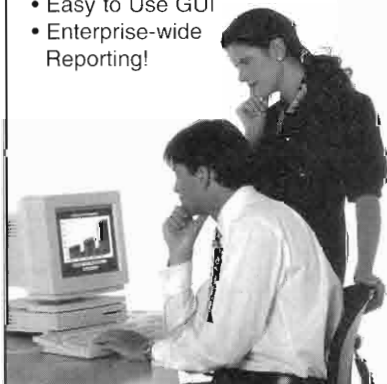
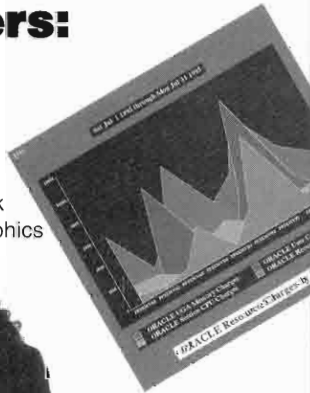

**GEJAC**  
INCORPORATED  
Specialists in System Accounting  
Established 1977

Call Now! 1.800.43ARSAP or 301.725.2500  
Email: info@gejac.com  
Or visit: http://www.gejac.com

CIRCLE 198 ON READER CARD

OUR 15th YEAR

### QUALITY HP WORKSTATIONS - WITHOUT THE HP PRICE

RENT · LEASE · BUY

Immediate Delivery On Most Items

### QUALITY MAINTENANCE FOR HP WORKSTATIONS

Ask About Our RAPID REPLACEMENT Low Cost Maintenance Programs Which Include On-Site Spares

- 700 SERIES: All Models
- X-STATIONS: ENVIZEX, C270X
- All 300, 400T and 400E Series
- Memory, Features & Disc Upgrades for all Workstations
- CPU Upgrades: All Models

More Than 1500 Satisfied Customers Throughout The USA and Worldwide

For technical info, specs or pricing call Mordy or Carol



**C.S.U. Industries, Inc.**  
395 Pearsall Avenue, Cedarhurst, NY 11516  
(516) 239-4310 FAX (516) 239-8374

CIRCLE 213 ON READER CARD



mended means of communication between an HP 3000 and other computers.

**Serial Connections** — Client-server communications also can be achieved via serial connections. This entails an actual physical connection between the personal computer and the HP 3000 via a DTC port. Although this communications method can sometimes be very efficient, it usually requires a unique session and port from the HP 3000 system. Assuming that users still require a terminal logon in addition to their client-server access, this can become a systems management problem. The unneeded use of virtual memory for each logon, at least two per person, as well as the use of an additional port per person may negatively affect system resources.

The speed, flexibility, access to resources and options offered by a TCP connection is usually greater than that of a serial connection. Also, most DLLs that provide access to HP 3000s from

PC clients use only TCP networks and not serial communication.

**Modems** — Modems (Modulator/Demodulator) are devices that are used to connect PCs to HP 3000s via communication software available from third-party vendors. This communication is possible again with client-server applications. If a serial connection is used, the modem can make a direct connection to the HP 3000 port to establish communication to the server.

TCP connections, however, require the client to be a part of the PC network in order to allow access to the server. This is possible if the network is outfitted with software that allows the client to be a "node" of the network, even if the client is not physically connected to the network. Once the client becomes a node, it is able to perform tasks against the server. Unfortunately, this type of networking is currently expensive and cumbersome. The technology is available, however, if requested from the network vendors.

*Editor's Note: Part 3 of Building Client-Server Applications On The HP 3000, appearing next month, will focus on project management issues such as performance, security and outsourcing.*

Would you like to continue to see articles on this topic?  
Circle on reader card yes 350 • no 349

### About the Author:

Rohan Hall is a software consultant and co-founder of Hall, Wynter and Associates. He has developed various legacy and client-server applications on HP 3000 MPE/iX, UNIX, VAX/VMS, Data General, Microsoft Windows and DOS systems. He has over 12 years of experience in various areas of systems development. He has worked with Hewlett-Packard, Lockheed/Martin, Hughes Aircraft and Cognos Corp.

Rohan Hall can be reached at: rhcon@aol.com, or (719) 532-9246; (303) 412-8651



LOOKING FOR  
A BETTER SERVICE PLAN?

## HP and Sun Service

### Make a Lasting Difference.

Contemplating a change? Maybe it's time to rethink your service assumptions. Polaris has new, flexible, reliable alternatives for HP 9000 and Sun users that will make a lasting difference.

We will show you how to take better advantage of your resources, capitalize on new trends in computer service, and get a better return on your service investment.

Find out about your options. Call 800-541-5831 in the U.S., or +31-26-3116068 in Europe. You can also e-mail us at sales@polaris1.com in the U.S. and sales@polaris.nl in Europe.

#### Custom Service Plans

On-Site Maintenance  
Self-Maintenance  
Software Support

#### Education Services

Maintenance Training  
SunSoft Authorized  
Training

#### Expert Support

Help Desk  
Parts and Systems

See our homepage: <http://www.polaris1.com>

**POLARIS**

The Leader in Independent UNIX Systems Service.



# Waxing Eclectic

**Y**ou asked for it. So, this month's column is another "eclectic mix" that answers your questions.

So let's dig right in...

## SEARCH PATHS

It can be a bit of a challenge when people can access a system using different login programs like rlogin, telnet, getty and the window system login using VUE, XDM or CDE. The problem is in keeping the search paths from the various login methods the same. For example, if you put a new directory in the `/etc/profile` file's `path` variable, it won't make it to users logging in through VUE. Well, CDE uses a method that I have adopted for all logins. First, I will describe the CDE mechanism, then give an example of using this for non-CDE logins.

On HP-UX 10.10 and higher, there are some files in the `/etc` directory used to set default paths, they are `path`, `manpath` and `shlib_path`. These files contain path locations, in the same format as the path variables. They can be edited, and will then propagate to all users logging in through CDE. CDE does this with the `/usr/dt/config/Xsession.d/0060.srcsysenv` file. These files are sourced to the `Xsession` script at login time. The important line in this file looks like this:

```
export PATH="$PATH:`cat $PATH_FILE`"
```

The variable `$PATH_FILE` is set to `/etc/PATH` earlier in the script, so this adds all locations in the `/etc/PATH` file to the user that is log-

ging in's search path. The `manpath` and `shlib_path` variables are set similarly.

This makes it easy to add to, or change, the search path for all users of this system. Just edit the `etc/PATH/` file, and it will affect all the CDE logins.

This is especially true if you realize that the `/etc/PATH` file could be automatically distributed (`rdist?`) so that changes could be networkwide very easily. As soon as I saw this method, I liked it. The only drawback is that it's only for login sessions started with the `Xsession` script. Because this is such an easy way to make paths uniform, I just adapted it to other login methods, having them read the same file. Here is how to get it into command line or telnet logins:

The CDE `Xsession` script, which starts a login session, sets a variable (`DT`) that is supposed to be used in your `.profile` (or `.login`) file to determine if this is a CDE login or not. It is not documented very well, but basically mimics the method used in the VUE environment. Here is pseudo code of the `Xsession` file when sourcing in the `.profile/.login` files:

```
export $DT = true
source users .profile or .login
unset $DT
```

So, you are supposed to enclose any commands in your `.profile` or `.login` script that should not be run during a

CDE session inside an `if` statement, just like we did in VUE. The example below is a mix of pseudo code and real shell scripting, and shows how you might go about having the shell use the `/etc` files to set the `searchpath` and `manpath`, as well as keeping `stty` commands out of the CDE `Xsession` command (note: this is a `.profile` example, not a `.login` example):

```
if [ "$DT" != "true" ]; then
  export PATH="$PATH:`cat /etc/PATH`"
  export MANPATH="$MANPATH:`cat /etc/MANPATH`"
  # stty and other terminal commands not to be
  # run during a CDE login go here
fi
```

## LROM ON 10.10

I learned about this from the HP-UX System Admin mailing reflector. Someone was having trouble using LaserROM on a 10.10 system with only CDE loaded. And when they called to report the problem to the Response Center, they were told it is not supported under CDE. Interesting. And bothersome. It turns out though, that if the system only has CDE on it, you will have troubles. But if VUE is also loaded, LROM will work.

## MANLY MAN-K

`man -k` is another problem reported on the mailing list that caught my attention. I use `man -k` quite often on HP-UX 10, because there are so many new commands. If you are not familiar with it, `man -k` (also called `apropos` on some systems) allows you to supply a keyword. Then, it searches a text file of one-line man page descriptions, and reports back with lines that match (a grep-like search). For example, the command `man -k dta` would report back a list of all commands descriptions



that had the letters **dta** in them, like **dtappintegrate**, **dtaction**, etc. The problem was, the command that creates this database that **man -k** reads was doing a core dump when you ran it. That command is **/usr/lib/mkwhatis**, which is really a symlink to the **/usr/sbin/mkwhatis** shell script. Here's what I got when running it:

```
/usr/sbin/mkwhatis[87]: 6625 Memory fault(coredump)
/tmp/whatiscompr: No such file or directory
```

The error message showing the brackets, and a line number means it is a shell script, and the problem occurred on line 87 or so. Because it is a shell script, and I did not feel like waiting for a patch, I decided to look at it. Turns out that most of the script up to line 87 is all one big long pipeline. The problem was, which command caused the coredump. Looking at the dump file reveals the following:

```
core file from 'deroff' - received SIGSEGV
```

So, the offending command seemed to be **deroff**. With some edits to the file, looking at the intermediate stages of the pipeline, this was true, everything worked up to the **deroff** command.

Therefore, as a temporary fix, remove the **deroff |** characters from line 85, leave the rest of that line alone, and you do get a **/usr/share/lib/whatis** file created, which is the file that **man -k** uses.

Of course, it still has some formatting directives in there, **deroff** was supposed to remove them. This means there will be some funny characters in the output of **man -k**, but at least it works till HP comes up with a patch. By the time you read this, there might already be a patch, but this technique of troubleshooting can be used for other problems in the future.

#### A LOVELY .PROFILE

If you can't get your **.profile** or **.login** startup files read in when using CDE,

it's usually caused by using a shell name other than those that CDE expects, like **tsh** or **bash**.

If you have this problem, look in that users **~/.dt/startlog** file. If you see the following message: **non-standard shell \$SHELL**, here is the cause and fix to the problem. In the CDE Xsession file (**/usr/dt/bin/Xsession**), the section that sources in the users login startup file

looks like this:

```
if [ "$DTSOURCEPROFILE = "true" ]; then
  case ${SHELL##*/} in
    sh | ksh) shellprofile="$HOME/.profile";;
    csh)      shellprofile="$HOME/.login";;
    *)       Log "non-standard shell $SHELL"
  esac
fi
```

The **dtsourceprofile** variable is set to **true** in the users **~/.dt/profile** file if they want the login startup file to be read. If it is set, then the second line strips the leading path from the contents of the **\$SHELL** variable, and leaves just the shell name (**/usr/bin/sh** becomes **sh**).

This is checked against the two cases looking for **sh**, **ksh** or **csh**. If it is not one of those, it falls to the default line (the asterisk), and uses the function **Log** to write the non-standard shell error message to the startlog file. To fix this, simply add the shell names and startup file name you want executed. Here are the corrected lines for the **tsh** and **bash** shells:

```
bash | sh | ksh) shellprofile="$HOME/.profile";;
tsh  | csh)      shellprofile="$HOME/.login";;
*)    Log "non-standard shell $SHELL"
```

If there are other shells used on your system, just add a line above the default line for that shell name, and assign the **shellprofile** variable to the proper file for that shell.

If you think we've spent too much time on CDE, guess again. HP, at least as of this writing, *will not be shipping VUE* starting with HP-UX 10.20, so start learning it!

— *Just how fast can you learn CDE? Tell Fred about your progress at frederm@aol.com*

Would you like to continue to see articles on this topic?  
Circle on reader card yes 306 • no 305

# Concerned about System Security?



## Get with the Program

Control & Audit  
root access.

Secure and Manage  
Login & Passwords.

Secure Network  
Communications.

Call us.



tel: 403.264.4822  
fax: 403.264.0873  
www: <http://www.fsa.ca>  
email: [info@fsa.ca](mailto:info@fsa.ca)  
1011 first street SW suite #508  
calgary alberta canada T2R 1J2

© 1995, 1996 FSA Corporation. Trademarks are property of their respective owners.

CIRCLE 197 ON READER CARD



# The Webification Of OpenView

**T**he World Wide Web now touches just about everything. You know Web technology is ubiquitous,

when your kids can recite URLs faster than phone numbers. I half expect to see my Welsh Corgi surfing for [www.milkbones.com](http://www.milkbones.com). Well, maybe not. But HP OpenView is no exception to the Webification of life. HP has indeed added Web interfaces to several of its key networking and systems management products, including a major HP OpenView partnership that includes integration of Netscape products with HP's IT/Operations, PerfView and IT/Administration products, as well as HP's Network Node Manager (NNM).

HP is also expecting to use Sun's Java as possible components of OpenView's distributed architecture. They have even publicly demonstrated a Java-based prototype of NNM. This activity is in response to pressure coming from Web-intoxicated customers. But is Web access really all you need? It certainly provides one answer: convenient access to management data. But does it make the job of network management that much easier?

## WELCOME TO MY NIGHTMARE

Since the latter part of the 1980s when customers started replacing proprietary network architectures with heterogeneous TCP/IP infrastructures, network and systems management has been a nightmare-in-progress: different kinds of management data, stored in different formats, in all sorts of incompatible

databases. Although most management data is transported via SNMP (thank goodness for one least common denominator protocol), it still comes out in various formats and gets dumped into various flat files, SQL databases and object-oriented repositories across the network.

You want to print out a report showing the average end-to-end response time of a particular application, with a breakout of delays caused by the various routers, bridges, hubs and other links over which that application travels. Dream on. Each network device has its own management application with its own database; and although you can look at it all from an OpenView screen, you still can't just dump the data in a big pot, stir it around and turn it into common sense. So what does this have to do with Web-based management? Plenty.

Some customers naively think that adding a Web interface solves the problem of incompatible management data. Web browsers are platform-independent, right? Java is platform independent, right? Right — almost — they are portable only in the most extreme sense. *But portability and interoperability are NOT the same thing.* Just because a browser can read management data doesn't mean all your existing management applications can process and use that data. What a human being can see and understand is

quite different than what a software program expects to see so it can add, subtract or compare data to a result (such as a report on network performance). Without a universally accepted set of standard definitions for management devices, management applications will still be "islands" unto themselves, even if the applications are all written in Java.

## IT'S A CONTENT PROBLEM

Why? Because there's a difference between "containers" and "contents." Although you and I can both use Java to write applets for processing management data using the same object class "containers," if our "contents" are described differently, my Java applet won't be able to feed data into your Java applet — unless we agree in advance on how the information about managed devices is to be described. If the industry could move to universally accepted descriptions, then the problems with non-interoperable management applications could be addressed.

HP seems to understand the problem. And I'm guessing that's why they have agreed to assist Microsoft, Compaq and a number of other influential vendors in the industry in a new initiative announced in July called the Web-based Enterprise Management standard. This effort involves specifying and putting a new protocol, a new data model and a new schema into the public domain:

- **Hyper Media Management Protocol (HMMP)** — a new protocol for transporting SNMP and other management data over HTTP.

- **HyperMedia Object Manager (HMOM)** — a new data model for



consolidating management data from different sources.

• **HyperMedia Management Schema (HMMS)** — a new schema for an extensible data description for the managed environment.

### INSTRUMENTING AS A WAY OF LIFE

HP is most actively contributing to HMMS, which specifies a standard set of object classes and definitions for developers to use when instrumenting network devices, systems and applications. Instrumenting means tagging the important thing that a network manager needs to know when there's a problem — such as device names and

**Some customers naively think that adding a Web interface solves the problem of incompatible management data.**

address status (up? down?), configuration data, version number, recent operating setting and so on. HMMS will define what management data looks like in a format that programs, as well as the human behind the browser, can understand.

The Web-based Enterprise Management effort is truly ambitious — many vendors are involved — so it could easily get bogged down in vendor infighting. But it won't if customers who are tired of struggling with non-interoperable management applications will push HP and the other vendors to write code and turn this announcement into a product. Putting a Web interface onto your management tools is a good strategy. HP has already done this for you. But don't stop there. HP knows this isn't enough. Tell them you know it too.

—Tell Jill what you know about Web-based management at [jill@int.snmp.com](mailto:jill@int.snmp.com).

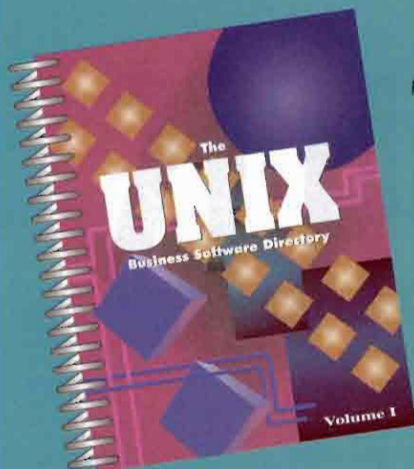

## The UNIX Business Software Directory

is being offered at the special price of just \$99.95 (a 34% Savings off the regular price of \$150).

**SAVE 34% WITH THIS SPECIAL OFFER!**

## NEW FOR 1996! THE SOURCE BOOK OF SOURCE BOOKS FOR UNIX USERS.

Packed with more UNIX business software vendor and product data than you've ever seen in one place. Now you can review in an instant, evaluate objectively and buy with total confidence.

**PURCHASE YOUR COPY NOW!**

**CALL: 1-800-285-1755**

Outside of the U.S.: Call 908-225-2727

The UNIX Business Software Directory, Volume I

### ORDER CARD

**YES!** Please send me \_\_\_\_\_ copy(ies) of **The UNIX Business Software Directory** at the special price of just \$99.95 (a 34% savings off the regular price of \$150).

Payment enclosed

Charge my:  VISA  Mastercard  AmEx

Account # \_\_\_\_\_

Signature \_\_\_\_\_ Exp. Date \_\_\_\_\_

Bill my company\* \*(Please attach purchase order.)

#### DON'T FORGET

✓ Checks payable to Cardinal Business Media, Inc.

✓ Please add \$10 for shipping & handling—\$3 for each additional book.

✓ Add applicable tax CA, CT, IL, ME, NJ, NY, PA, TX

#### SEND TO:

Name _____		Title _____	
Company _____			
Address _____			
City _____		State _____	Zip Code _____
Phone _____		Fax _____	

Mail to: EBM Books c/o Wharthurst & Clark • 100 Newfield Avenue • Edison, NJ 08837

HPTP1096

Would you like to continue to see articles on this topic?  
Circle on reader card yes 358 • no 357

# *new* Products

## Platinum Technology Launches UNIX Version of Desktop DBA

Platinum Technology Inc. announced a UNIX version of PLATINUM Desktop DBA. Desktop DBA for Motif is designed to increase UNIX database administrators' productivity by replacing the need to memorize SQL syntax for hundreds of RDBMS commands with point-and-click commands.

Desktop DBA for Motif is available immediately for HP-UX and Sun Solaris. Support for IBM AIX is scheduled. Desktop DBA for Motif currently supports Oracle, Microsoft SQL Server and Sybase. Prices start at \$2,490.

Contact Platinum Technology, 1815 S. Meyers Rd., Oakbrook Terrace, IL 60181; (800) 442-6861; info@platinum.com; www.platinum.com.

*Circle 400 on reader card*

## OneWave, Sterling Sign Agreement

OneWave Inc. (formerly Business@Web) and Sterling Commerce announced they will work together to provide Internet integration to make it easier for small companies to do business electronically with their EC-enabled suppliers, customers and business partners. The Sterling/OneWave solution enables companies to exchange business transactions with large trading partners via simple Web forms that feed directly into Sterling's G:TRAN family of EC messaging servers.

Contact OneWave, One Arsenal Marketplace, 2nd Fl., Watertown, MA 02172; (617) 923-6500; info@onewave.com; www.onewave.com.

*Circle 395 on reader card*

## Net-Scene Provides Point Plus for Netscape

Net-Scene announced its PointPlus Plug-in for Netscape Navigator client software. PointPlus interacts with other objects on

the Web page using the Netscape LiveConnect framework. Net-Scene's PointPlus Plug-in users are able to publish PowerPoint presentations into content that can be uploaded to intranets and the Internet via Netscape Navigator Gold.

The PointPlus graphics and compression engine converts the presentation with end user transparency. When using PointPlus to convert presentations, the user can either fill in the required information in one screen, or can be guided, step by step, through the screens with the help of a wizard guide.

Price is \$499. PointPlus requires Microsoft Windows 95 or Windows 3.1, or Windows NT 3.51 and PowerPoint 4.0 or later. The Net-Scene PointPlus Plug-in for Netscape Navigator works on Windows 3.1 or later, Windows 95 and Windows NT 3.51.

Contact Net-Scene, 3737 Broadway, Ste. 340, San Antonio, TX 78209; (800) 375-5531; info@net-scene.co.il; www.net-scene.com.

*Circle 375 on reader card*

## LinkStar Announces SmartHost

LinkStar Communications announced that it will license SmartHost, a client-server technology that simplifies the process of Web site hosting and virtually eliminates human involvement in the hosting process by removing the manual set-up requirements associated with current hosting models.

Web sites are uploaded to any SmartHost server using LinkStar's Site Launcher, instant Web site publishing software.

The technology behind SmartHost is called Simple Web Update Protocol (SWUP), which is based on the http, but extends http's capabilities to facilitate automatic account creation, Web page publishing and information dissemination.

Contact LinkStar Communications Corp.,

5201 Congress Ave., #C-232, Boca Raton, FL 33487; (561) 995-0005; info@linkstar.com; www.linkstar.com.

*Circle 399 on reader card*

## Confluent Introduces Visual Thought

Confluent announced Visual Thought, a cross-platform diagramming and flowcharting tool for the corporate enterprise.

Visual Thought runs on UNIX and Windows. It can replace many special-purpose tools, such as: CASE tools, flowcharters, graphics packages for documentation, network diagrammers, presentation graphics tools, 2D visualization front-ends and back-ends.

Contact Confluent, 132 Encline Court, San Francisco, CA 94127; (800) 780-2838; info@confluent.com; www.confluent.com.

*Circle 398 on reader card*

## ISIS Selects Simba Technologies

Simba Technologies Inc. announced that Isis Distributed Systems has chosen Simba Technologies' SimbaExpress to be integrated as part of the Isis database replication solution. SimbaExpress is a data access technology that enables Isis to provide their replication customers with quick and efficient access from a Windows-based system to a wide range of important corporate databases.

Simba SDK products include SimbaEngine, SimbaEngine Client/Server and SimbaLib.

Contact Simba 2125 Western Ave., Ste. 301, Seattle, WA 98121; (206) 441-0340; info@simbatech.com; www.simbatech.com.

*Circle 396 on reader card*

## UniSolutions Associates Releases UNISOL JobAcct

UniSolutions Associates released UNISOL JobAcct Version 2.2.5 with expanded resource accounting capabilities, including application-specific accounting functions for ISPs and universities, and enhanced disk usage accounting. UNISOL JobAcct is a complete system monitoring, resource accounting, and billing solution for UNIX systems that allows organizations to provide system access and services to other organizations, or to distribute work across multiple projects to maintain control over system resource usage.

Licenses for single machines start at \$1,595. The product runs on HP-UX 9.0.x and 10.x, UNIX SVR4, Digital UNIX 3.2 and 4.0, SunOS 4.x, Solaris 2.x, SGI Irix 5.3 and 6.x, IBM AIX 3.2 and 4.1, NCR UNIX 3.0 and Amdahl UTS.



Contact UniSolutions Associates, 33586 Via Lagos, Dana Point, CA 92629; (714) 488-3960; craig@unisol.com; www.unisol.com.

*Circle 393 on reader card*

## Lucent Technologies Offers Graphics Software

Lucent Technologies' Software Solutions Group announced new versions of RIO for MS-DOS, RIO Designer and RIO Designer Professional.

RIO is an MS-DOS-based object-oriented graphics and animation program that uses vector-based drawing tools and resolution-independent technology. RIO version 7.2 features include enhanced font rendering capabilities and input and output to live video.

RIO Designer runs on Windows 3.1, Windows 95 and Windows NT. It is a 32-bit graphic design and illustration software program for creating high impact photo—realistic images.

This is a 32-bit graphic design software for creating high-impact, photo-realistic images. RIO Designer Pro takes advantage of Windows NT features such as multitasking and multiprocessing.

Contact Lucent Technologies' Software Solutions Group, 2701 Maitland Center Pkwy., Maitland, FL 32751; (407) 662-7724; brad@mss.lucent.com; www.bell-labs.com/org/ssg.

*Circle 397 on reader card*

## AMI Releases AMIDiag 5.0

American Megatrends Inc. (AMI) released AMIDiag 5.0. This latest version of AMIDiag offers a comprehensive list of tests, including diagnostics for the new PentiumPro processor, CD-ROM drives, SCSI devices, PCI bus and Plug & Play devices. AMIDiag 5.0 has tests for motherboards that have up to 16 processors on-board and a maximum of 4 GB of system memory. AMIDiag 5.0 comes on one 3-inch disk, and does not have to be installed on a hard drive to diagnose computer problems. Contact AMI, 6145-F Northbelt Pkwy., Norcross, GA 30071; (800) 828-9264; www.megatrends.com.

*Circle 376 on reader card*

## Citadel Announces NetOFF 5

Citadel Computer Systems Inc. released NetOFF 5, an automatic logoff software program. The new version adds the ability to save open files at logoff on both 32- and 16-bit applications. The program also is designed to run on all operating systems including Microsoft NT and Novell NetWare.

NetOFF 5 prevents unauthorized access to open workstations and prevents corrupt backups caused by open files. NetOFF 5 employs a unique "virtual user" function which systematically performs all necessary functions to save open files just as if a user were sitting at the console. NetOFF 5 also can be configured to execute logoff commands at a specific time of day, day of the week or day of the month.

System requirements include Novell NetWare 3.x or 4.x, Windows NT, Windows 3.1x or Windows 95.

Contact Citadel Computer Systems Inc., 2950 North Loop West, Ste. 1080, Houston, TX 77056; (800) 962-0701; contact@citadel.com; www.citadel.com.

*Circle 374 on reader card*

## LBM Systems Introduces Forms & Fonts

LBM Systems announced Forms & Fonts, which provides HP-UX users with the ability to enhance their UNIX printed reports and eliminate the need for pre-printed forms. It uses forms created by any forms generation package. It also can send merged data and overlays to PCL and PostScript laser printers. And, it permits UNIX, Wang VS and AS/400 forms to be interchanged without conversion costs.

Forms & Fonts: can add up to 99 fonts

per page on any UNIX report; produces shading, italic and bold fonts; multiple colors supported on each page; complex job instructions are supported; eliminates "burst and separate" of multiple part forms by sequencing and collating them; merges data from any application with logos, barcodes, postal codes, signatures and MICR fonts; filters and interprets data from any application software; and data can be positioned by field names, not position, so that fields can be tagged and the overlay, not the application, is changed.

Contact LBM Systems Corp., 145 Cherry St., New Canaan, CT 06840; (800) 898-6434; andyw@lbmsys.com; www.lbmsys.com.

*Circle 391 on reader card*

## Suprtool Reads Allbase Tables

Robelle Consulting announced that Suprtool added another database to the list of files that it can access. Suprtool 3.0 adds access to HP ALLBASE/SQL databases on HP 9000 and HP 3000 platforms by means of the select command. The Allbase access module is priced as an add-on module to the basic Suprtool package. The basic package includes the Suprtool extraction utility, the Suprlink multifile linking tool, and the STExport utility to prepare data in formats that can be imported into spreadsheets and

## New From HP

**HP Precision Engineering for Windows NT** — HP announced it has made three of its HP Precision Engineering (HP PE) product-development software solutions available for Windows NT — HP PE/SolidDesigner for 3D product modeling, HP PE/SheetAdvisor for sheet metal design, and HP WorkManager clients for product data and workflow management.

The Windows NT versions offer the same capabilities as the UNIX system workstation version. Also, the Windows NT and UNIX versions work together, which permits concurrent design in heterogeneous environments comprising UNIX system workstations and Windows NT clients.

Prices for HP PE/SolidDesigner, PE/SheetAdvisor and WorkManager clients for Windows NT begin at \$7,500, \$18,000 and \$1,000, respectively.

**High-Resolution Broadband Test Solution** — HP introduced a sweep/ingress analyzer designed to enable broadband communications engineers and technicians to test the forward and return paths and to quickly troubleshoot their cable TV systems despite the presence of ingress.

The solution is based on HP's DigiSweep technology — a fast, high-resolution, digital services-compatible sweep. It uses on/off signals to sweep the forward and return paths without interference. The sweep technology is compatible with cable modems, telephony, interactive TV, digital music services and Internet communications.

The new sweep/ingress analyzer consists of a portable field unit — the HP CaLan 3010R — and a rackmount-headend unit — the HP CaLan 3010H. Both units are priced at \$5,950 each.

*For more information, contact your local sales office or call (800) 533-1333.*

The DECUS logo features a stylized 'D' icon to the left of the word 'DECUS' in a bold, sans-serif font, all contained within a rectangular border.

*Seminars*  
*Symposium*  
*Trade Show*

# ANAHEIM

*November 9-14, 1996*

- Solutions to Technical Problems
- Valuable Personal Networking
- The Industry's Best Training and Education Source for Those Working with Windows NT, Digital UNIX, and OpenVMS

- *The Internet*
- *Application Development*
- *Network Management*
- *Integration/Migration*
- *Systems Management in a Client/Server Environment*
- *Information and Database Management*
- *And More!*

**For More Information:**

1-800-DECUS55

<http://www.decus.org>

Featuring  
Keynote Sessions  
by Digital Chairman  
**Robert Palmer**  
and Microsoft Chairman  
**Bill Gates**

TAKING  
YOU WHERE  
YOU NEED TO BE

The DECUS logo features a stylized 'D' icon to the left of the word 'DECUS' in a bold, sans-serif font, all contained within a rectangular border.

CIRCLE 271 ON READER CARD

*Celebrating 35 Years • 1961-1996*



databases on various platforms. Contact Robelle Consulting Ltd., Unit 201, 15399 - 102A Ave., Surrey, BC V3R 7K1; (800) 561-8311; info@robelle.com; www.robelle.com.

Circle 390 on reader card

**Magic Software Announces Magic V7**

Magic Software Enterprises released Version 7 of the Magic Rapid Application Development system. This 32-bit release for Windows 95, Windows NT and the Internet brings a new emphasis on component reusability, along with support for OLE 2.0. This release also includes improved GUI functions and significant performance enhancements for the Magic client and server architecture.

Price for a single-user Windows development network system begins at \$3,500. Pricing for enterprise client development begins at \$3,500, and enterprise server development starts at \$4,750.

Contact Magic Software Enterprises Inc., 1200 Main St., Irvine, CA 92714; (714) 250-1718; uzi@magic-inc.com; www.magic-sw.com.

Circle 394 on reader card

**Miros Inc. Announces TrueFace CyberWatch**

Miros Inc. announced TrueFace CyberWatch, which uses face recognition technology to allow only authorized users to access sensitive data such as medical, financial, criminal or military records.

TrueFace CyberWatch uses Miros' software and a small video camera on top of the monitor to verify computer users when they try to access protected data from their computers.

The TrueFace CyberWatch client runs on Windows 95 and Windows NT. The client software is priced at \$199 per computer, while a complete client package, including Connectix camera and software, is priced at \$298. The server software runs on Windows NT, NetWare 4.x and UNIX, and is priced by the number of users.

Contact Miros Inc., 572 Washington St., Wellesley, MA 02181; (617) 235-0330; michaelk@miros.com; www.miros.com.

Circle 392 on reader card

**CenterLine Unveils QC/Advantage**

CenterLine Software introduced QC/Advantage, an open lifecycle software quality management system automate software testing and test management. QC/

Advantage helps developers and quality assurance professionals develop, manage and execute consistent, repeatable tests for multiple application releases and versions for more frequent and thorough testing. It consists of six components: a uniform user environment; an object-based test foundation; a distributed test designer; a parallel execution executive; a consolidated results analyzer; and an open integration platform.

It is available for HP 9000 HP-UX,

and SunOS and Solaris for SPARC and UltraSPARC systems, as well as Windows 3.1, Windows 95 and Windows NT clients. Prices for a starter pack, which includes five licenses, onsite installation, training and consulting is \$37,995.

Contact CenterLine Software, 10 Fawcett St., Cambridge, MA 02138; (617) 498-3000; info@centerline.com; www.centerline.com.

Circle 389 on reader card

HP RENTALS • HP RENTALS • HP RENTALS • HP RENTALS

HP WORKSTATION  
SALES & RENTALS



WORKSTATIONS

807	E55	<b>NEW!</b>	755	750	CRX	433 S	CRX	382	360	332
827	F20	C110	735	730	CRX-24	425 T	VRX	362	350	330
847	G30	J210	725	720	CRX-24Z	425 S	GRX	380	345	320
E25	H40	D310	715	710	CRX-48Z	425 E	PVRX	375	340	310
E35	I70	D350	712	705	GRX	400 S/T	EVRX	370		
		K220								

AND MORE ...

Printers Plotters	X Terminals APOLLO ON Series	PC's Memory	Discs Test Equipment	800 Series Data Acquisition
----------------------	---------------------------------	----------------	-------------------------	--------------------------------

TSA is THE place for daily, weekly, monthly or long term rentals of Hewlett-Packard equipment. Ask about our 6-12 month purchase plans. Equipment available for same day shipment.

1-800-422-4872

713/935-1500 • Fax 713/935-1555 • Email: info@tsa.com



Authorized  
Rental  
Company





THE RIGHT EQUIPMENT. RIGHT NOW.



2040 West Sam Houston Parkway N. • Houston, Texas 77043

HP RENTALS • HP RENTALS • HP RENTALS • HP RENTALS





# PRODUCT showcase

**RECERTIFIED H-P EQUIPMENT**



**BUY TRADE  
RENT SELL**

Server	Disk Drive	Monitor
Workstation	CD-ROM	PC's
Printer	Tape Device	X-Terminator
Language	Memory	Upgrade's

---

**800-VIA-TECH**



**800-842-8324**

Ask for a Certified HP Sales Professional for assistance. 112. VIA Technology is a Hewlett-Packard Channel Partner.

VIA Technology  
1467 Stevens Suite 300  
San Antonio, TX 78205

210-227-7726 voice  
210-227-6222 fax  
2024.1.2008@viatech.com

CIRCLE 492 ON READER CARD

**ADAGER**

**The Adapter/Manager for  
IMAGE/SQL Databases**  
obsoleted the need for database  
reloads back in 1978 and became  
the de facto standard for  
HP3000 systems worldwide.



Channel  
Partner



Sun Valley, Idaho 83353-3000 U.S.A.  
Toll-free from Canada and the USA:  
Tel 800 533-7346 Fax 800 247-7346  
From other parts of the world:  
Tel 208 726-9100 Fax 208 726-8191

CIRCLE 121 ON READER CARD

Remanufactured HP 9000 Servers, Workstations

**Workstations  
INTERNATIONAL**

**Serious HP Solutions**

**HP 9000**

**QUALITY REMANUFACTURED SYSTEMS**

**SCIENTIFIC WORKSTATIONS**

**BUSINESS SERVERS**

**FULL 90 DAY WARRANTY**

**QUICK TURNAROUND**

Large HP Inventory **IN STOCK**  
**1-800/842-4781**  
Call for ALL your HP needs!

601 Lakeshore Parkway, Suite 1160, Minnetonka, MN, USA: 55305  
612 / 449 - 9000 PH 612 / 449 - 3198 FAX  
e-mail: info@workstations.com

Printers / Plotters / Network Hardware

CIRCLE 458 ON READER CARD

**Introducing the First and  
ONLY Source of OpenView  
Information Available!**

**Focus on OpenView:**  
*A Guide to Hewlett-Packard's Network  
and Systems Management Platform*

**Book Highlights:**

- The OpenView Framework
- Systems Management
- OperationsCenter
- Managing the Physical Network
- Managing the Multivendor Enterprise Network



**\$10**

**Place your order now! Call Toll Free**  
**1-800-285-1755**  
**Or FAX 215-643-8099**

ST. PAUL SOFTWARE'S

**EDI Solutions**

for Unix, Midrange, Mainframe, PC

- Powerful EDI Translation
- GUI Visual Mapping
- Flexible Scheduling
- Application Integration to Oracle  
SAP, CA-MANMAN and others



Channel  
Partner

**for HP 3000 and HP 9000**



**ST. PAUL SOFTWARE**  
1450 ENERGY PARK DR, ST. PAUL, MN 55108  
TEL 612/603-4400 FAX 612/603-4403  
SALES 800/998-4EDI (4334)

WWW <http://www.spedi.com> Email [info@spedi.com](mailto:info@spedi.com)

CIRCLE 465 ON READER CARD

**S**urety  
systems, Inc.

**Hewlett Packard Equipment  
And Maintenance Services**

- HP 9000
- HP 3000
- HP 700 Series Workstations
- HP Peripherals

**(713) 466-9455**

A World Apart. A Phone Call Away.



Channel  
Partner



CA-Unicenter



Advanced  
Matrix  
Technology

Houston, TX. FAX (713)466-9454

CIRCLE 226 ON READER CARD

<http://www.iodatasy.com>

- ★ Internet On HP
- ★ Faxing From HP
- ★ DataComm Consolidation
- ★ High Availability



**I/O Data Systems, Inc.**

HP 3000 HARDWARE  
HP 9000 HARDWARE  
HP CERTIFIED



Channel  
Partner

**I/O Data Systems, Inc.**  
Ph. 216-835-2211 • Fax 216-835-0220  
Email: [iodata@interramp.com](mailto:iodata@interramp.com)  
"An Inc. 500 Company"

CIRCLE 272 ON READER CARD

**HEWLETT PACKARD**

*Depot Repair*

- Expert Depot Repair
- 5 Day Turnaround
- Emergency Exchange Program



**BLACK RIVER  
COMPUTERS**

**1-800-837-0061**  
216-365-9950 Ohio  
216-365-3916 FAX

CIRCLE 158 ON READER CARD

<http://home.navisoft.com/csi6000>



Channel  
Partner



Reflection  
AUTHORIZED VAR

- Expert Pre-Sale Consultation
- New HP Business Systems
- Integration of PC Networks
- Systems Integration
- Rentals And Outsourcing
- Disaster Recovery Services

**Computer Solutions, Inc.**  
**201-672-6000**

CIRCLE 209 ON READER CARD

# CAREER opportunities

## Data Agents, Inc.

### Attention Brokers:

Small eight person family owned company, 5 years old, seeks to expand into HP/DEC pre-owned market.

Currently in Wang/Sun/Mac, we offer serious stock options for the right person to launch this new division based in beautiful colonial Williamsburg.

120-B Tewing Road  
Williamsburg, VA 23185  
voice: 757/220-5896  
fax: 757-220-8181

## HP CAREERS NATIONWIDE

The employment market is HOT! Skills needed:

- HP3000, HP9000, Client Server
- Application Development, System Management
- COBOL, Powerhouse, Speedware
- Progress, Oracle, Powerbuilder, C++
- Any RDMS
- MPE-iX, HP-UX, HP Openview

CALL, FAX, OR E-MAIL



Diane Amos, CPC

### Amos & Associates

633-B Chapel Hill Road  
Burlington, NC 27215  
Phone: (910)-222-0231  
FAX: (910)-222-1214

E-Mail: fansamos@netpath.net  
Home Page: <http://resourcecenter.com/amos>  
"Celebrating 20 years as Professional Recruiter"

CIRCLE 204 ON READER CARD

## CONSULTANT showcase



### Immediate Job Openings

SW Consulting, Inc. has immediate openings for candidates with the following HP3000 experience:

Speedware Cobol Turbo Image Omnidx/Imsam

Salaries for professionals with one or more of these skills range from \$55k - \$85k/yr. If you have any of these skills and are not earning top dollars for your knowledge and would like to pursue a career as an Information Systems Consultant, then mail or fax your resume to:

SW Consulting, Inc.  
13180 N Cleveland Avenue Phone: (800) 494-4977  
Suite 112 (941) 656-1011  
N. Ft. Myers, Florida 33903 Fax: (941) 997-0456

We offer relocation packages and signing bonuses to consultants who qualify.

CIRCLE 255 ON READER CARD

## new products

### Data Express ODBCLink Optimized For Axiant 4GL

Cognos and M.B. Foster Associates announced that DataExpress' ODBCLink, M.B. Foster Associates' ODBC interface for HP 3000 users, is now optimized to work with Axiant 4GL, Cognos' client-server development tool. DataExpress' ODBCLink provides Axiant 4GL users with robust multiuser, multitransaction read and write capabilities to file systems residing on MPE/iX. Supported file systems include TurboIMAGE, KSAM, MPE files, OMNIDEX and Oracle, as well as PDL dictionaries and PowerHouse subfiles.

Contact Cognos, One Burlington Business Center, 67 S. Bedford St., Ste. 200W, Burlington, MA 01803; (800) 426-4667; [www.cognos.com](http://www.cognos.com).

Circle 388 on reader card

### Silvon Software Adds Interfaces To Helpline

Silvon Software enhanced its Helpline incident management system with the addition of a Macintosh client interface and Internet access through the Web. Helpline currently runs on HP-UX, SunOS, Solaris, OpenVMS, Digital UNIX and Windows NT, with Windows and Macintosh client interfaces.

The system features a common GUI across system platforms, character cell interfaces, along with interfaces to e-mail and the Internet.

Contact Silvon Software Inc., 420 Bedford St., Lexington, MA 02173; (800) 262-8296; [helpinfo@silvon.com](mailto:helpinfo@silvon.com);

Circle 387 on reader card

### Integration Alliance Corp. Introduces Business Builder

Integration Alliance Corp. launched Business Builder, a process for developing resellers' business plans to set long- and short-term direction. Business Builder's training and strategic planning are designed to help resellers handle the high level of growth in the HP channel.

It evaluates opportunities and matches them with resources. And, the process helps resellers audit their company's core competencies and develop a clear mission statement, as well as analyze market segments where resellers are likely to succeed.

Contact Integration Alliance Corp., 5445 DTC Pkwy., P4, Englewood, CO 80111; (303) 770-5980; [info@icorp.com](mailto:info@icorp.com).

Circle 385 on reader card

## HARDWARE

### Lexmark Releases Color Jetprinter 2050

Lexmark International Inc. announced the Color Jetprinter 2050, which combines superior performance, 600 x 600 dpi four-color print quality and Lexmark's third-generation Windows printing system.

The announcement also marks the debut of the Lexmark Workshop, a CD-ROM that provides the user with an array of full-function applications that will be packed with each 2050 printer at no additional charge.

It is compatible with Windows 3.x, Windows 95, Windows for Workgroups 3.11 and DOS applications running under Windows. Price is \$299

Contact Lexmark International, 740 New Circle Rd., NW, Lexington, KY 40511; (800) 358-5835; [www.lexmark.com](http://www.lexmark.com).

Circle 384 on reader card

### Accton Rolls Out Ethernet/FAX Modems

Accton Technology Corp. shipped a new family of Ethernet/FAX Modem multi-function PC adapters.

The EN2218-3 combines Accton's MPX Ethernet adapter with a 28.8 Kbps FAX modem. The Ethernet Y-cable has RJ-45 and RJ-11 connectors making it easy to connect to a 10BaseT network and a telephone outlet simultaneously; no extra cabling or additional accessories are required. The EN2218-4 uses Accton's Combo Module which allows users to connect to a 10BaseT or 10Base2 network, as well as a telephone line at 28.8 Kbps. The EN2218-1 combines Accton's MPX Ethernet adapter with a 14.4 Kbps fax modem and Y-cable cable.

The EN2218-1 14.4 Kbps modem/Ethernet adapter with Y-cable is \$379. The EN2218-2 14.4 Kbps modem/Ethernet adapter with Combo Module is \$399. The EN2218-3 28.8 Kbps modem/Ethernet adapter with Y cable is \$529. The EN2218-4 28.8 Kbps modem/Ethernet adapter with Combo Module is \$579.

Contact Accton Technology Corp., 1962 Zanker Rd., San Jose, CA 95112; (408) 452-8900; [support@accton.com.tw](mailto:support@accton.com.tw); [www.accton.com](http://www.accton.com).

Circle 383 on reader card

### ADIC, Access Graphics Offer Automated Tape Libraries

ADIC and Access Graphics announced an agreement which offers ADIC's complete line of high-performance automated tape



libraries and standalone subsystems to the Access network of VARs.

Products in the offering include ADIC's family of DLT tape storage products, including the multiple-drive, midrange Scalar DLT libraries, the seven-cartridge VLS DLT tape libraries and single-drive subsystems. Also available will be ADIC's line of 4mm (DAT) and 8mm desktop tape storage products, including single- and dual-drive compact libraries and standalone subsystems.

Contact ADIC, 10201 Willows Rd. NE, P.O. Box 97057, Redmond, WA 98073; (800) 336-1233; support@adic.com; www.adic.com.

Circle 382 on reader card

### 4824 Adapter Broadens Interphase Performance

Interphase Corp. announced the 4824 EISA 100BaseT Adapter for HP 9000 servers and workstations. The 4824 offers a 32-bit bus mastering architecture, full-duplex operation, auto-negotiation and adaptive FIFOs.

Price for the 4824 EISA 100BaseT Adapter is \$750.

Contact Interphase Corp., 13800 Senlac, Dallas, TX 75234; (214) 654-5000; fastnet@iphase.com; www.ipphase.com.

Circle 380 on reader card

### Model 3100 Stacker Available For HP 5Si Laser Printers

Stands & Stackers Inc. (SASI) announced the Model 3100 stacker for the HP 5Si printers. It is capable of stacking up to 3,100 sheets of 8.5- x 11-inch paper face down when used with the 2,000 sheet feeder. The unit comes fully assembled, just insert the casters. Price is \$389.

Contact SASI, 14 W. Front St., Monroe, MI 48161; (313) 242-0826; patil@annis.com; www.stacker.com.

Circle 379 on reader card

### Hybrid Networks Introduces Wireless Cable Modem System

Hybrid Networks Inc. introduced a new cable modem/router and a Point of Presence (PoP) server tailored to the wireless cable technology market, which uses microwave transmission to deliver data at very high speeds from the Internet directly to a subscriber site.

The HAS wireless PoP server is centrally located in a computer room or networking hub connected to the Internet backbone.

The Client Cable Modem 161 Wireless is an external modem/router that connects to a LAN or directly to a PC via a standard

10BaseT Ethernet connection. When it is connected to a LAN, a single Hybrid Networks modem/router can support up to 20 PCs.

System configurations start under \$50,000. The Client Cable Modem 161 Wireless supporting a LAN is \$995.

Contact Hybrid Networks Inc., 10161 Bubb Rd., Cupertino, CA 95014; (408) 725-3250; info@hybrid.com; www.hybrid.com.

Circle 378 on reader card

### U.S. Robotics Ships Courier I-Modem

U.S. Robotics shipped the Courier I-Modem with ISDN/V.34, which combines the features of an ISDN terminal adapter and U.S. Robotics' V.Everything analog modem in a single device.

The I-Modem includes an integrated NT-1, providing a direct connection to an ISDN wall jack and an analog device port to connect telephone, fax or answering machine. The Universal Connect feature automatically detects ISDN or analog calls

and connects at the highest possible speed supported by the device on the other end. Price ranges from \$495 to \$695, depending on configuration and form factor.

Contact U.S. Robotics, 6600 Sillicca Way, Gilroy, CA 95020; (800) 881-7256; sales@usr.com; www.usr.com.

Circle 381 on reader card

### DILOG Produces Ultra Windjammer

DILOG/Diverse Logistics Inc. introduced a new RAID controller that furnishes throughput rates of 40 MBps and supports concurrent RAID 0, 1 and JBOD configurations without the need for on-board cache memory. The Ultra Windjammer RAID controller provides a single-ended ULTRA SCSI host channel and two single-ended SCSI-2 Fast/Wide disk channels. An optional differential ULTRA SCSI host channel also is available. Price is \$2,185. Contact Diverse Logistics, 2862 McGaw Ave., Irvine, CA 92714; (800) 345-6432; www.dilog.com.

Circle 377 on reader card

# WEB SITE

## PLATINUM technology, inc.

Read PLATINUM Edge Magazine Online, featuring technical articles on today's hottest IT issues.

Stay up-to-date on PLATINUM technology, one of the most dynamic forces in open enterprise systems management software. Access information on PLATINUM's solutions for application development, business intelligence, data warehousing, database administration, and systems management, from one of the Web's best-designed sites.



<http://www.platinum.com>

RATES: 1x \$700    6x \$600  
3x \$650    12x \$550

CONTACT:

Lisa Merck

(630) 655-0100 • (630) 655-0755 fax



# Spam, Spam, Wonderful Spam. Not!

**N**ot long ago, the Internet was governed by an Acceptable Use Policy, which included strict

provisions about what could be sent across the Internet. Commercial traffic was nearly taboo and a culture emerged that effectively censured anyone attempting to market goods or services. When the NSFnet, the federally-sponsored backbone for the Internet, was shut down in favor of a privately provisioned network, the Acceptable Use Policy no longer applied. The Internet was, as they say, "open for business."

## GREEN EGGS AND SPAM

While many businesses leveraged the advantages of the Internet with respect for its traditions, a new brand of entrepreneurs emerged that found the Internet (especially the vast number of electronic mail and Usenet newsgroup readers) an irresistible place for scams. The combination of huge electronic mail address lists and human greed has made junk e-mail a serious problem.

"Spamming," the practice of sending unwanted, unsolicited commercial messages on the Internet, is at an all-time high. Once considered simply an annoyance, spamming is now a danger to many network managers. Many unsolicited advertisements are returned to their sender via a reply feature in electronic mail software. The backlash against spamming has caused some overzealous Internet users to return not one, but tens of thousands of messages to the spammer. This attempt to overload the source of the junk mail, some-

times called a mailbomb, often has the consequence of shutting down the spammer's Internet Service Provider's mail server. But it can have unintended consequences as well.

## THE LAW OF UNINTENED CONSEQUENCES

One particularly ruthless marketer on the Internet found that nearly every message he received in response to his marketing survey was a antagonistic message questioning his practice. After receiving thousands of these messages, he retaliated by returning a mailbomb to those who dared complain about the junk mail. The resulting chaos left several networks incapacitated until mail servers could be restarted and mail feeds flushed.

Anyone on your network who has subscribed to mailing lists or has responded to Usenet messages is likely to receive unsolicited commercial electronic mail. Electronic mail addresses are not private or unlisted to the outside world. Several companies have emerged that harvest lists of electronic mail addresses from Usenet newsgroups and shared interest mailing lists for the purpose of mass electronic mailings. Several of the companies that maintain these lists are reputable and have reasonable practices, but there are always those looking to make a quick dollar on unsuspecting networked users. With the unintended consequences that are possible, what's a network manager to do?

A basic approach is to respond to the sender of the message. Many legitimate mass mailing operations honor requests to be removed from mailing lists. The sender's reply address should be listed in the mail message header. Look for "From:" or "Reply-to:" fields in the header that can be used for requests to stop commercial messages. Unfortunately, these headers can be "forged" to make it impossible to trace the source of the message. Replies to forged messages are simply returned to the sender with an error message.

If you are the victim of a network full of unwanted messages from a single, forged source, you can also attempt to contact the mail manager at the originating site for relief. If you can figure out the sender's site, sending a request for help to the POSTMASTER at that site may help. Look for a field in the message headers marked "Message-Id: and note the host and domain name to the right of the @ symbol. A short message with a copy of the offending message to the POSTMASTER of that site often brings quick results. Remember, the system manager at the source site is often unaware that one of their own customers is creating the problems.

Electronic mail spams are likely to continue, but an active approach to limiting the scope of the problem will limit the accumulated effect on you and your users. Check out the Internet Abuse Frequently Asked Questions page at [www.cybernothing.org/faqs/net-abuse-faq.html](http://www.cybernothing.org/faqs/net-abuse-faq.html) for further information.

— *Have you been spammed? Tell Mark about it at [73740.1101@compuserve.com](mailto:73740.1101@compuserve.com).*

Would you like to continue to see articles on this topic?  
Circle on reader card yes 304 • no 303



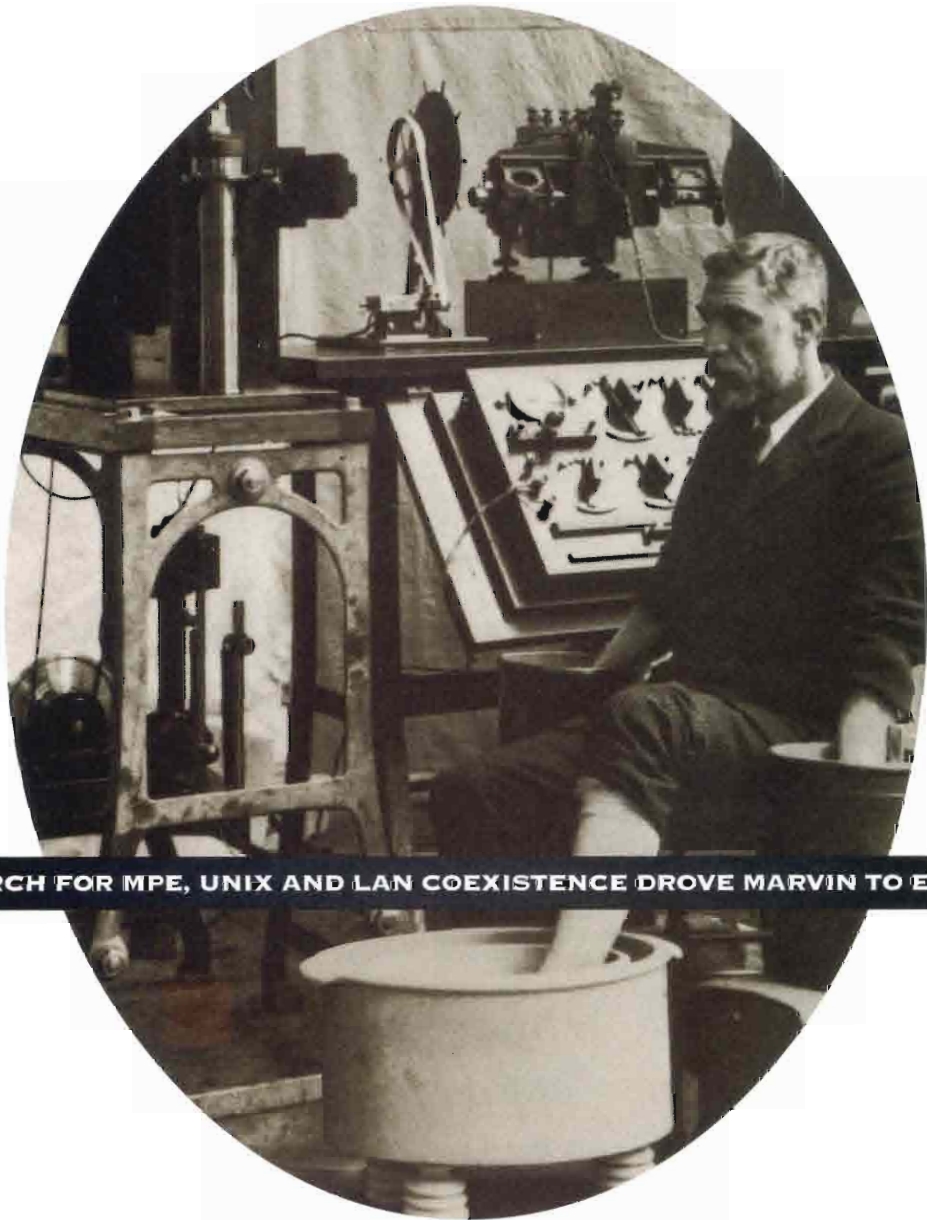

t

HE SEARCH FOR MPE, UNIX AND LAN COEXISTENCE DROVE MARVIN TO EXTREMES.

THANKFULLY HE FOUND *Quest*, THE PERFECT COEXISTENCE PARTNER.



Marvin discovered that *Quest* offers a complete suite of coexistence solutions. *SharePlex Bridge*, the newest addition to the *Quest* family, provides shadowing from MPE to UNIX, NT and PCs. *NFS/iX* offers transparent file access between MPE and virtually every other platform. *NetBase Client* provides socket-based access to *TurboIMAGE* from UNIX and PC applications. And *NBSpool* offers transparent print management across MPE, UNIX, mainframes, LANs and WANs. To see what Marvin discovered, call us at 800 306.9329. The end of your quest for true interoperability is just a phone call away.

610 Newport Center Drive, Suite 1400, Newport Beach, CA 92660. Phone: 714-720-1434. Fax: 714-720-0426  
UK: +44(0)1905-797935 · www.quest.com · info@quest.com · All names are trademarks of their respective owners.

 **QUEST  
SOFTWARE**  
*Expect a solution.*

CIRCLE 269 ON READER CARD

MONDAYS,  
AS DESIGNED BY  
NETWORK PROFESSIONALS.

PCWEEKLAB  
**ANALYST'S  
CHOICE**  
OCT. 9, 1998  
Reflection Suite for X

ENTERPRISE-WIDE  
CONNECTIVITY, AS DESIGNED  
BY NETWORK PROFESSIONALS.

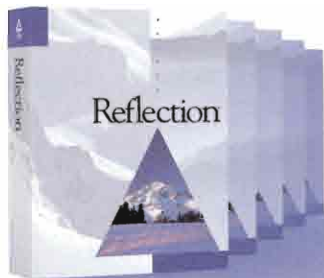

If it were up to you, your hard work would finally pay off. Mainframes, PCs, minicomputers and servers would all fit together seamlessly, and Monday would be just another day at the beach.

Impossible? Not with Reflection<sup>®</sup> from WRQ. Reflection offers complete, integrated PC connectivity software for your entire enterprise—including transport protocols, PC X server software, and terminal emulation. All with the management features, open standards, and service and support you need.



#### REFLECTION<sup>®</sup> SOLUTIONS

##### REFLECTION PC-TO-HOST CONNECTIVITY SOFTWARE

- ▲ UNIX, X, HP, DIGITAL, AS/400 AND 3270 CONNECTIVITY
- ▲ WINDOWS, DOS, AND MACINTOSH PLATFORMS
- ▲ INTUITIVE OPERATIONS, FAST FILE TRANSFER, ADVANCED TEXT AND GRAPHICS EMULATION, AND POWERFUL PROGRAMMING TOOLS

##### REFLECTION NETWORKING SOFTWARE

- ▲ COMMUNICATIONS: TCP/IP, UDP, LAT, NS/VT, IPX/SPX, SLIP, CSLIP
- ▲ ARCHITECTURE: VxD/DLL DESIGN; 100% WINDOWS SOCKETS COMPLIANT
- ▲ FULL-FEATURED APPLICATIONS (FTP, LPR/LPD, INTERNET ACCESS)
- ▲ EASY CONFIGURATION AND MANAGEMENT
- ▲ OPTIMIZED FOR MOBILE/WIRELESS COMPUTING

AVAILABLE AS SUITES AND INDIVIDUAL PRODUCTS, TAILORED FOR ANY ENTERPRISE CONFIGURATION.

To try connectivity designed from your point of view, call today for a free evaluation copy. We'll make sure that from here on out, your Mondays go swimmingly.

For a FREE evaluation copy,  
of any Reflection<sup>®</sup> product, call  
**800.926.3896**

**WRQ Reflection**  
CONNECTIVITY FOR A CHANGING WORLD

CALL 800.926.3896 IN EUROPE, CALL +31.70.375.11.00  
OUTSIDE EUROPE, CALL 206.217.7100  
INTERNET: sales@wrq.com WEB: http://www.wrq.com

WALSER RICHTER & QUINN, INC., 11500 DEXTER AVENUE, NORTH BERRY, WASHINGTON, MS 39208  
▲ WILHELM-MARK-HAUS, HEINRICH-HEINE-ALLEE 53, 40213 DÜSSELDORF, GERMANY / FAX: +49 211 83407 246  
▲ WILHELM-STRASSE 10, 10117 BERLIN, GERMANY / FAX: +49 30 253 24 24  
▲ ALL OTHER TRADEMARKS ARE THE PROPERTY OF THEIR RESPECTIVE HOLDERS.