

JUNE 1996

Professional

Opening
Windows
at **HP** PAGE 30

INSITES:
New
Dimensions
For **RKS
Design** PAGE 16

Kindred Systems

An **HP 9000** Family Reunion
Is Only A Chip Away



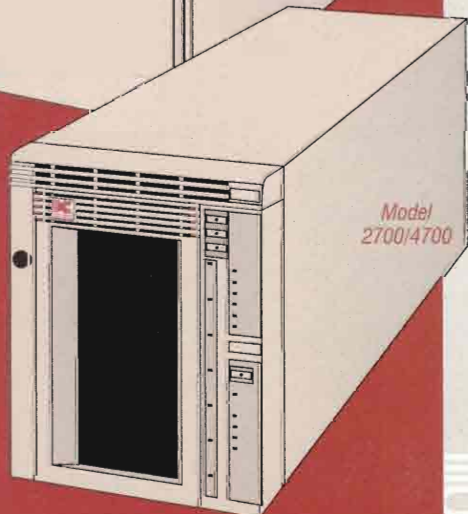
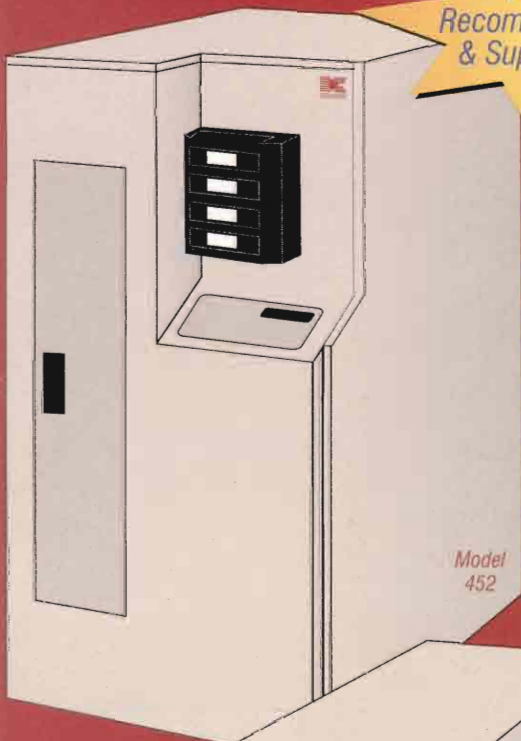
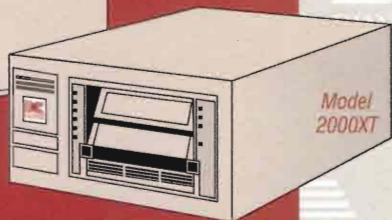
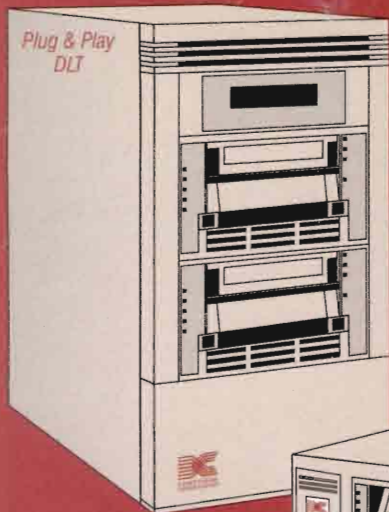

DLT Tape Solutions for Your HP 9000

Capacity, Performance & Reliability

These are all advantages inherent to Digital Linear Tape (DLT) technology. Your data-intensive applications require an "industrial strength" solution. DLT Tape offers exceptional durability and data integrity along with the ability to grow easily with your emerging needs.

Concorde Technologies, Inc. provides a full line of DLT tape solutions.

DLT Drives

- 20-40 GB Capacity/Tape*
- SCSI-2 Interface
- 2 Year Warranty
- 1040 GB Library Capacity*
- 1.5-3.0 MB/Sec. Drive Transfer Rate*
- 80,000 Drive MTBF
- 10,000 Hour Head Life

DLT Libraries

- 1-9 Drives/Library
- 3-of-9 Bar Code Reader
- Up to 264 DLT Cartridges
- Capacities to 10 TB/Library*
- Operator Load Port
- Hewlett-Packard Support
- Throughput to 1.3 TB/Hour*
- Cost-Effective Upgrades

DLT Software

- Backup/Restore Software
- "Hot" Database Backup
- Bar Code Support
- Client/Server Support
- HSM Software
- OmniBack II Support
- Lights Out Automated Operation
- Heterogeneous Network Support

Concorde specializes in high-performance network backup/restore solutions for HP 9000 Servers and Workstations. Backed by HP experience and a commitment to support, Concorde is an established leader among Hewlett-Packard Channel Partners.

To discuss your specific application or for a free backup/restore solutions catalog, contact a Concorde Sales Engineer.



800-359-0282



Concorde Technologies, Inc.
9770 Carroll Center Road, Suite F, San Diego, CA 92126-6504 USA
(619) 536-5500, (800) 359-0282, Fax: (619) 566-4396
E-mail: info@concordetech.com
<http://www.concordetech.com>

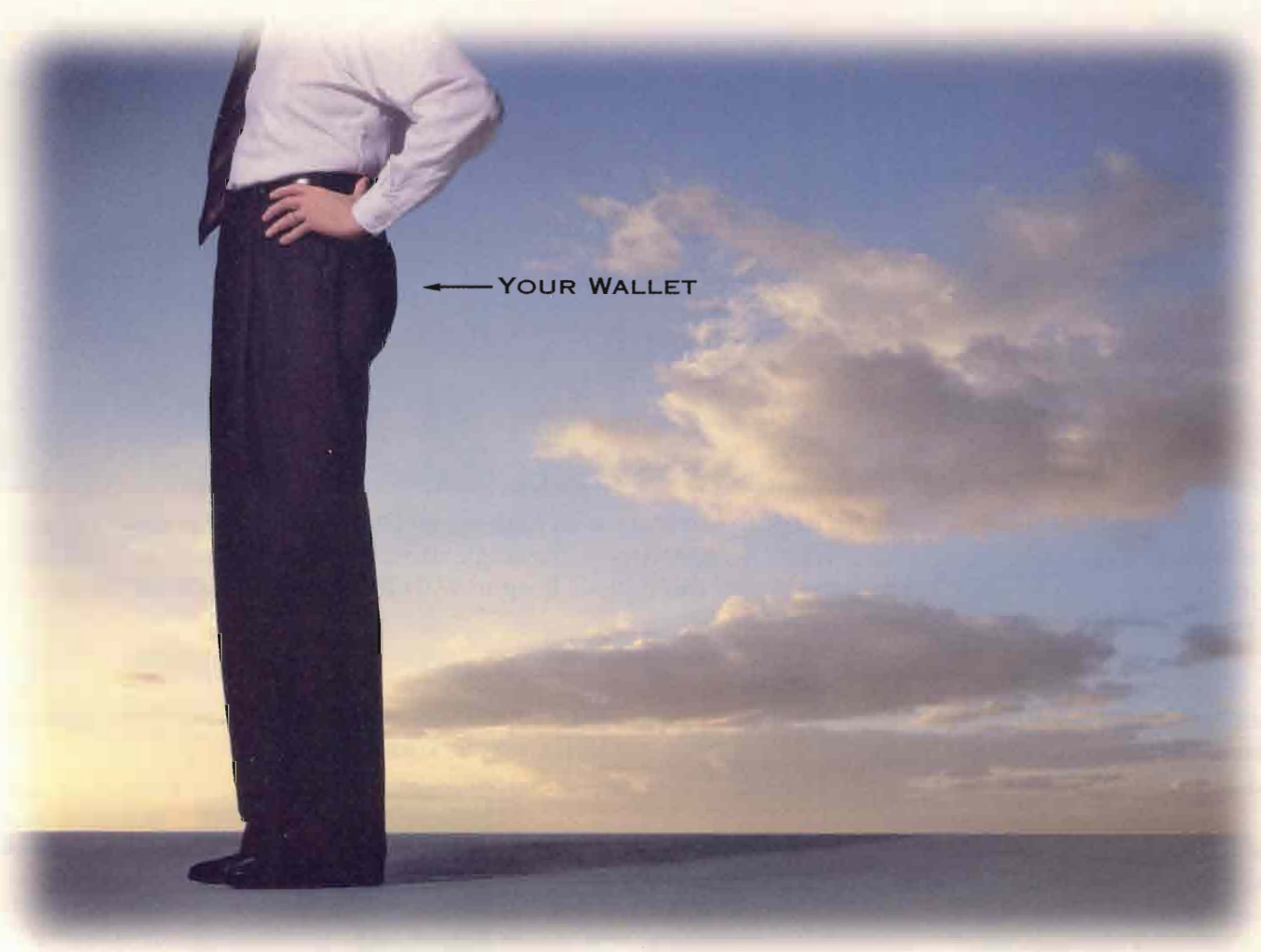

← YOUR WALLET

THERE'S ONLY ONE PLACE YOU'LL NOTICE A DIFFERENCE BETWEEN OUR MEMORY AND THE SYSTEM MANUFACTURER'S.



It's a little-known fact. Kingston® memory has exactly the same components, technology, and specifications as the leading workstation manufacturer's memory. Yet it costs up to 50% less. Maybe that's why more and more computing professionals are choosing Kingston, the memory specialists. After all, Kingston is the world's leading manufacturer of memory. Our engineers customize the design of each module according to the specifications set by workstation



manufacturers. In fact, Kingston has licensing agreements with Sun Microsystems® and Silicon Graphics®, plus service agreements with DEC™ and IBM®. And just to prove how confident we are in our memory, we give it a lifetime warranty.

To get the memory that's just right for your workstation, call our toll-free number: (800)435-0669. You'll find that our memory is

identical to your workstation manufacturer's in every way, except one: the price.

Kingston
TECHNOLOGY CORPORATION

For more information call us at (800) 435-0669



Visit our Web site: <http://www.kingston.com/kp.htm>

*Kingston has licensing agreements with Sun Microsystems to manufacture 100% compatible memory for SPARCServer 20, SPARCStation 20, SPARCServer 10, SPARCStation 10, UltraSPARC 1, and UltraSPARC 2; and with Silicon Graphics to manufacture 100% compatible memory for ONYX workstation, Challenge server, and Poseidon Challenge computer systems. Kingston Technology Corporation, 17620 Siskiyew Street, Fountain Valley, CA 92708 USA. (714) 435-2600. Fax (714) 435-2699.
© 1996 Kingston Technology Corporation. All rights reserved. Kingston Technology is a registered trademark of Kingston Technology Corporation. All other products or services are the trademarks or registered trademarks of their respective holders.

Alex meets DLT...



and they back up at full speed

Now IEM offers Alexandria Network Backup Librarian with high-speed DLT libraries, so you can relax while your network backs up FAST! With DLT4000 drives, the single drive transfer rate is up to 3 MB/sec. with 2:1 compression; with 9 drives, the library throughput is up to 97.2 GB/hour! DLT4000 cartridge capacity is 40 GBytes with 2:1 compression.

Alex backs up to DLT libraries with 2 to 9 DLT4000 drives and 28 to 264 cartridges.

These libraries are so reliable that they include a full one-year on-site warranty with next business day response.

Alex also backs up to IEM's 4mm and 8mm carousels and autofeeders, as well as 3480 tape libraries and HP's optical libraries.



Alex supervises every facet of your heterogeneous UNIX network backup:

- Organizes and automates your system backups
- Manages all of your backup media
- Performs cold database backups of Oracle, Sybase and Informix databases
- Performs hot backups of Oracle databases with an additional module

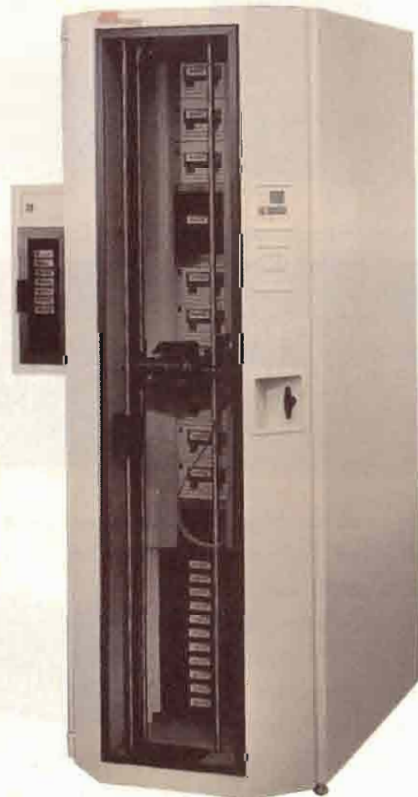

IEM: Providing Solutions for a Lights-out Environment

CIRCLE 122 ON READER CARD

In the U.S. and Canada:
IEM, Inc., P.O. Box 1889
Fort Collins, CO 80522 USA
Phone: (970) 221-3005
(800) 321-4671
Fax: (970) 221-1909

In the United Kingdom:
IEM, Inc., Unit 6, Salisbury House,
Wheatfield Way, Hinckley Fields,
Hinckley, Leicester LE10 1YG
Phone: +44 (0)1455 239000
Fax: +44 (0)1455 239668

All others:
IEM International Sales
1629 Blue Spruce Drive
Fort Collins, CO 80524 USA
Phone: +[1] 970-221-3005
Fax: +[1] 970-221-1909



Contents

June 1996

Vol. 10, No. 6

All Worked Up

By Marty Poniatowski

Add a new workstation here. Add some new servers there. Then for fun, add some parallel processing servers. Keeping up with HP's 9000 product line is a full-time challenge. But don't get worked up, we've done the job for you.

20

OPEN SYSTEMS FOCUS

Windows NT In The HP Enterprise

By George A. Thompson

In an exclusive HP Professional interview, Jonathan Goulden, director of HP's multivendor service and support program in HP's Worldwide Computer Support Organization, discusses the role and relationship of Windows NT in HP-UX environments.

30

COLUMNS

Industry Watch

By George A. Thompson

New HP PA-8000-Based C-Class Workstations; Visualizing New HP Graphic Subsystems; Integrating Windows NT; HP Restructures The Computer System Organization; HP Internet Update. 8

UNIX At Large: Making Peace With Pax

By Fred Mallett

Some backup functions are difficult with **tar** or **cpio**. All we are saying is give **pax** a chance. 32

Inner Networking: We Come Not To Bury NT

By Jill Huntington-Lee

Friends, programmers and IS managers, this month HP praises Windows NT with the introduction of the HP "IT Collaboration" program. 34

& Another Thing...: Get Control, Defeat Chaos

By Mandeep Khara

Covering your assets not only makes you look good, it can save your company a heap o' money. 48



| | |
|---|----|
| Editorial | 7 |
| New Products | 38 |
| Reader Information/ Advertiser Index | 41 |
| Product Showcase | 46 |

STRATEGIC DIRECTIONS:

| | |
|-----------------------------------|----|
| Kingston Technology Corp. | 12 |
|-----------------------------------|----|

PRODUCT WATCH:

| | |
|--|----|
| Forté Software's Forté Express | 14 |
|--|----|

INSITES:

| | |
|--|----|
| RKS Design Uses HP's ME30 Solid Modeling And HP's Precision Engineering (PE)/SolidDesigner Software To Build Products That Look Good And Work Well | 16 |
|--|----|

HP Professional

Cover image courtesy of Hewlett-Packard Co.

I.S. MANAGERS:

Read it, be prepared.

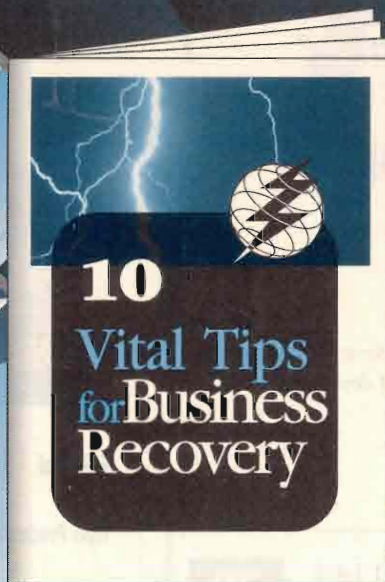

Yours Free.

Whoever said "what you don't know can't hurt you," clearly didn't have any critical data to protect. If you do – if being off-line for even a few hours means being out of business – you'll want to get your hands on *10 Vital Tips for Business Recovery*. This concise, clear and informative booklet is an indispensable guide to anyone who must formulate a winning recovery strategy in the information age.

Written by some of the country's foremost experts in recovering

distributed systems and client-server

applications in demanding environments, it's packed with answers to questions about everything from planning, to testing methodology, to the expectations you should have about your recovery service providers.

Best of all, *10 Vital Tips for Business Recovery* is **FREE**.

The more important your data, the more you'll want to read it.

Call 1-800-654-1689 today, for your free copy.



DATA ASSURANCE CORPORATION

We're ready when you aren't.

12503 East Euclid Drive, Suite 250, Englewood, Colorado 80111 303-792-5544

CIRCLE 466 ON READER CARD

HP PROFESSIONAL EDITORIAL ADVISORY BOARD

Patrick A. Adamiak

Marketing Manager for HP's Channel Partners (North America)

Nigel Ball

Marketing Director For HP's General Systems Division

Robert Bruen

Computing and Networking Manager at the MIT Lab for Nuclear Science

Frank Humphries

Director of Marketing at HP Asia Pacific Ltd.

Thomas Kucharvy

President of Summit Strategies

John R. Logan

Vice President of Aberdeen Group Inc.

Michael J. Meinz

Principal Technical Consultant at General Mills Inc.

Glenn Osaka

General Manager of HP's Commercial Systems Business Unit

Bard F. White

CIO and Worldwide Director of MIS for Spalding Sports Worldwide

UNIX is a registered trademark of AT&T in the U.S.A. and in other countries. MS-DOS is a trademark of Microsoft Corp. Macintosh is a trademark of Apple Computer Inc. X Window System is a trademark of MIT. Windows is a registered trademark of Microsoft Corp. Windows NT is a registered trademark of Microsoft Corp. NetWare is a registered trademark of Novell Inc.

HP Professional

EDITOR-IN-CHIEF Charlie Simpson
simpsoncm@box101.cardinal.com
SENIOR EDITOR George A. Thompson
thompsonga@box101.cardinal.com
ASSOCIATE EDITOR Deborah Schwartz
schwartzdr@box101.cardinal.com

INTERNATIONAL EDITIONS EDITOR Karine Simpson

COLUMNISTS

NETWORK MANAGEMENT Jill Huntington-Lee
PC NETWORKING Jim Carr
PC Miles B. Kehoe
UNIX Fred Mallett

CONTRIBUTING AUTHORS Mandeep Khara, Marty Poniatowski, Barry Slawter, Jon Toigo, Andrea Zavod

DESIGN & PRODUCTION

EXECUTIVE DESIGN DIRECTOR Leslie A. Caruso
ART DIRECTOR Al Feuerstein
ASSOCIATE ART DIRECTOR Jennifer Barlow

PRODUCTION MANAGER Carla Loughlin
PRODUCTION ASSISTANT Linda Hall

CIRCULATION

CIRCULATION DIRECTOR Carrie Eisenhandler
DIRECTOR OF FULFILLMENT Margie Pitrone

MARKETING

PROMOTIONS DIRECTOR Timothy M. Kraft
MARKETING MANAGER Veronica L. Sutsko
SENIOR GRAPHIC DESIGNER Christine Piatkowski
GRAPHIC DESIGNERS Mark Broomell, Patty Wall

PUBLISHER Leslie Ringe

CARDINAL BUSINESS MEDIA, INC.

PRESIDENT AND CHIEF EXECUTIVE OFFICER
Robert N. Boucher

CHIEF FINANCIAL OFFICER
Thomas C. Breslin

VICE PRESIDENT, PUBLISHING
R. Patricia Hernon

VICE PRESIDENT, HUMAN RESOURCES
Dorothy J. Flynn

VICE PRESIDENT, SPORTS & MUSIC DIVISION
Thomas J. Morgan

VICE PRESIDENT, RETAIL DIVISION
Marianne Houston

For more information on how to contact your sales representative, see page 41. For address changes and other subscription information, please call (708) 291-5212 or FAX (708) 564-9062. In the U.S., missed issues must be claimed within 45 days of publication date; outside the U.S., missed issues must be claimed within 90 days. Editorial, advertising sales and executive offices at 1300 Virginia Dr., Ste. 400, Fort Washington, PA 19034 • (215) 643-8000, Corporate FAX (215) 643-8099.

HP PROFESSIONAL ISSN 0896-145X is published monthly by Cardinal Business Media Inc., 1300 Virginia Dr., Ste. 400, Fort Washington, PA 19034. Subscriptions are complimentary for qualified U.S. and Canadian sites. For reprints, contact Reprint Management Services, 505 E. Airport Rd., Lancaster, PA 17601; (717) 566-2601, FAX (717) 566-2063. Periodicals postage paid at Fort Washington, PA 19034, and additional mailing offices. POSTMASTER: Send all correspondence and address changes to HP PROFESSIONAL, P.O. Box 3052, Northbrook, IL 60062. COPYRIGHT © 1996 by Cardinal Business Media Inc. CANADIAN POSTMASTER: Send all correspondence and address changes to Cardinal Business Media, C/O N.L., P.O. Box 44, RPO Rockwood Mall, Mississauga, ON L4Z 9Z9. All rights reserved. No part of this publication may be reproduced in any form without written permission from the publisher. All submitted manuscripts, photographs and/or artwork are sent to Cardinal Business Media, Inc. at the sole risk of the sender. Neither Cardinal Business Media, Inc. nor HP PROFESSIONAL magazine is responsible for any loss or damage. HP PROFESSIONAL is an independent journal not affiliated with Hewlett-Packard Company, HP and Hewlett-Packard are registered trademarks and HP PROFESSIONAL is a trademark of Hewlett-Packard Company.

Canada Post International Publication Mail Canadian Distribution Sales Agreement #IPM0264431

Printed in U.S.A.

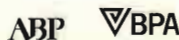



Now with ODBC Link

The Power of Integration

Unlock your HP3000 with DataExpress

If your end users can't reach the data they need, reach for DataExpress, the link you've been looking for between your HP3000 and Mac/PC desktops.

With DataExpress, users can pull information off your HP3000 without rekeying and without tying up your MIS people.

Best of all, they can bring data into PC and Mac applications that they already know and count on: Lotus, dBase, Excel, WordPerfect and more. With thirty output format options, DataExpress opens your data to more applications than any other integration package.

In addition to PC and Mac file formats, DataExpress can generate reports, and with the Report Designer option you get WYSIWYG capability, so you can see design improvements as you make them.

DataExpress is the #1 End-User Computing Environment available for the HP3000 today.

**For powerful solutions,
call 1-800-ANSWERS**

Your Integration Software Supplier[®]

M. B. Foster Associates Limited
50 Water Street
P.O. Box 580
Chesterville, Ontario
Canada K0C 1H0

Tel (613) 448-2333
Fax (613) 448-2588



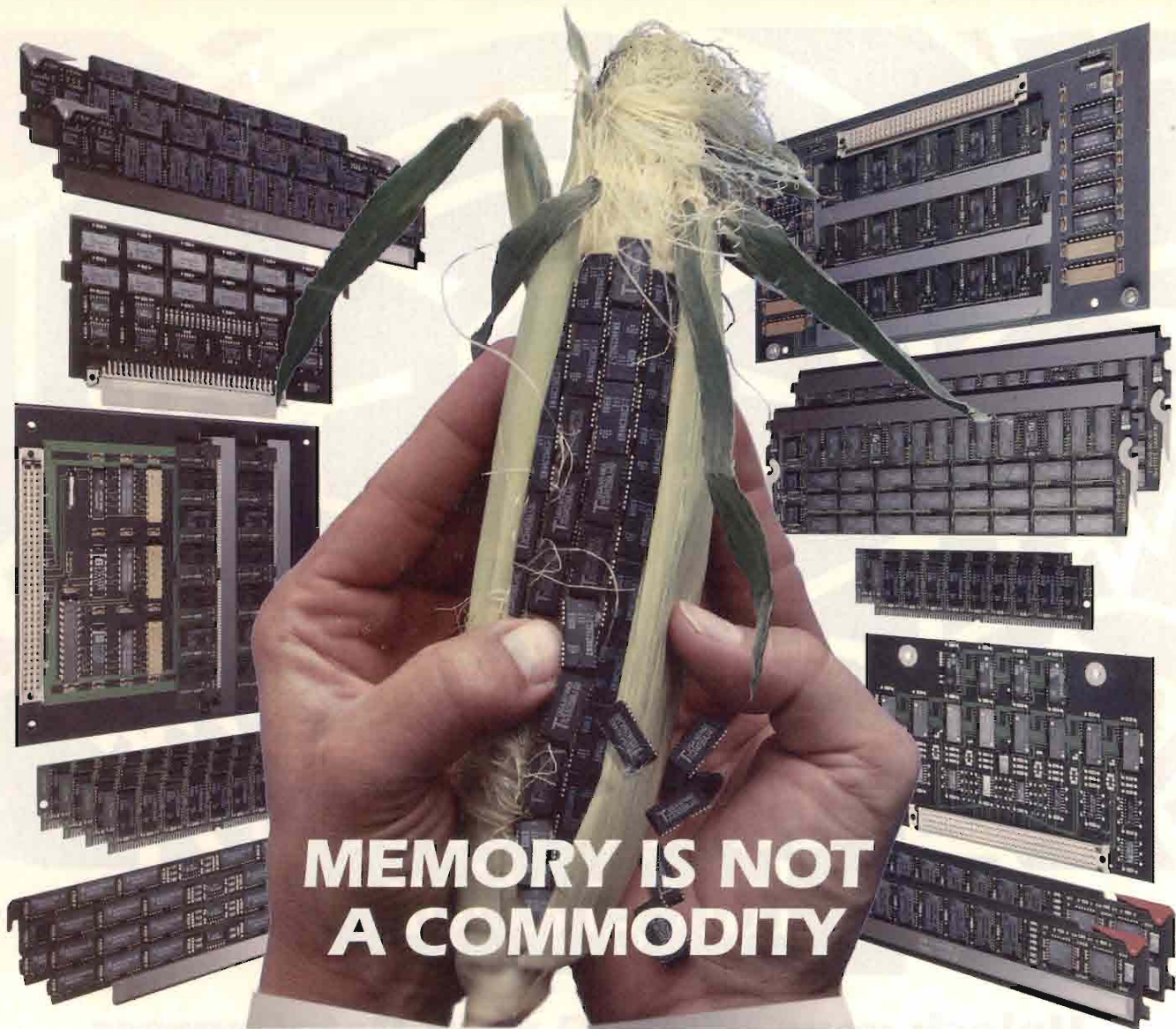

MEMORY IS NOT A COMMODITY

DRAMs are traded like soybeans, pork bellies and crude oil. The market is volatile. Prices change daily.

Well designed, properly configured and thoroughly tested memory products are as rare as spotted owls.

It's your workstation. Your work. When you need memory, call Newport Digital.

You'll get the quality and service you expect from the leader in HP workstation enhancements. Superior products. Outstanding technical support. Very competitive prices.

| HP Series | MB | 1 | 2 | 4 | 8 | 12 | 16 | 32 | 64 | 128 | 256 |
|-------------------|----|---|---|---|---|----|----|----|----|-----|-----|
| HP-200/310/320 | | • | • | • | • | | | | | | |
| HP-319 | | | | | • | • | | | | | |
| HP-330/350/370 | | | | | | • | | | | | |
| HP-332 | | | | | • | | | | | | |
| HP-340 | | | | | • | | | | | | |
| HP-345/375/380 | | | | | • | | | • | | | |
| HP-360 | | | | | • | • | • | | | | |
| HP-362 | | | | | • | • | | | | | |
| HP-382 | | | | | | | • | • | | | |
| HP-400/425/433 | | | | | | | • | • | | | |
| HP-425E | | | | | | | • | • | | | |
| HP-700RX | | • | • | • | • | | | | | | |
| HP-705/710 | | | | | • | • | | | | | |
| HP-715/725 | | | | | • | • | | | | | |
| HP-720/730/735 | | | | | | | • | • | • | | |
| HP-742/745/747 | | | | | | | • | • | • | | |
| HP-750/755 | | | | | | | • | • | • | • | |
| HP-8X/7/9X/7 | | | | | | | • | • | • | • | |
| HP-FXX/GXX/HXX/XX | | | | | | | • | • | • | • | |

Call today. Speak with an expert on Hewlett-Packard computers. See why memory worth having is not a commodity.

NEWPORT DIGITAL
1-800-383-3642

CIRCLE 246 ON READER CARD

“You Have To Be Nuts To Buy A Mainframe”

Not quite ready to commit to saying the mainframe is dead, Rich Sevcik, vice president and general manager of the Systems Technology Group, offered the title of this article as an official quote for the members of the press, last month in Palo Alto. Gathered with a couple hundred HP employees under a tent on HP's HQ picnic grounds, amid rock and roll music, burgers and brews, about 50 members of the international press witnessed HP CEO Lew Platt “unplug” HP's last mainframe. Or as Platt and Sevcik said, to watch HP “walk the walk.”

After a group sing-along of “The Day The Mainframe Died” to the tune of Don McLean's “American Pie,” Sevcik and Platt congratulated and thanked the Hewlett-Packard IS staff for moving all HP mission-critical business from the mainframe onto “open-system” platforms distributed over the world's largest “intranet” including HP 9000 and HP 3000 systems. Representing the IS staff instrumental to the migration, Bob Walker, vice president and CIO for HP, reiterated that HP trusts its future to its people and to open client-server computing. He then apologized for the damp weather. It seems the water spilled out of the mainframe when the plug was pulled.

In addition to yanking the cord, Platt celebrated HP's reported 25 percent increase in net earnings for fiscal 1996. Net earnings for the quarter were \$723 million, or \$1.37 per share. Then Platt threw in a last minute zinger announcing that HP's stock just made a two-for-one split moments before. The crowd went wild.

The “monolith” unplugging was part of a three-day HP media blitz including an International Editorial Symposium hosted at HP's Cupertino site. Members of the fourth estate from around the world, including Australia, Europe, India, Japan and the United States, were able to meet with key HP staff and management — from program managers to the President, CEO and Chairman Platt himself.

During an interview with *HP Professional*, Platt explained that in its efforts to provide leading edge solutions, sometimes HP winds up on the bleeding edge. “But that is the cost of being in the business.” Platt explained that it's HP's job to get “bashed in the nose sometimes” for its customers. However, he added that the “unplugging” would be viewed as anything but bloody. Platt says the ability to reinvent itself and re-approach strategies is the secret of HP's success; however, its challenge is to find new ways to grow while maintaining the culture that has led to the growth.

The HP unplugging was about 10 years in the making. According to Sevcik, there are about 20,000 mainframes still out there and this was only HP's last one. They now have to convert the other 19,999. The move to distributed computing will save HP over \$8 million a year, with no staff lost. All mainframe personnel were reassigned to other positions, not to mention a few promotions. And according to Robert Wayman, HP executive vice president and CFO, there will be a \$25 million to \$30 million in additional annual savings from implementing HP's internal PC Common Operating Environment over HP's own intranet.

HP's private network, which serves over 90,000 employees at 400 locations, consists of 84,000 PCs, 23,000 UNIX system desktops, 6,000 servers, 1,600 Web servers and Netscape on 60,000 desktops. Check out the July issue for an inside look at HP's intranet. The 30 applications, which were migrated from the mainframes in fewer than 28 months during the final phase of transition, included HP's order processing, purchase agreements and the ever critical payroll. The final phase was led by Jim Murphy, manager of the Mainframe Alternative program. Murphy said the biggest challenge was maintaining the status quo of a growing company that placed increased demands on its IS resources during the transition. In addition, there were some people who “needed to be coaxed along” to the new way of thinking. Seems like a typical IS shop. Of course, this one is responsible for a \$32 billion company.

When asked if he thought he'd be attending a UNIX unplugging in 10 years, Platt says he believes that in the end there will be two operating systems — UNIX and Windows NT. And that if there ever is a UNIX unplugging, he'll “be dead or won't care.” Sounds like a good attitude to me. Maybe this distributed computing stuff really works after all?



Charlie Simpson

simpsoncm@cardinal.com

INDUSTRY WATCH

George A. Thompson

HP'S NEW WORKSTATIONS ARE PACKIN' 64-BITS

Yes, it's true. Introduced and orderable this month, HP's newest workstations — the Model C160 and the Model C180 use 160 MHz and 180 MHz versions (respectively) of HP's 64-bit PA-

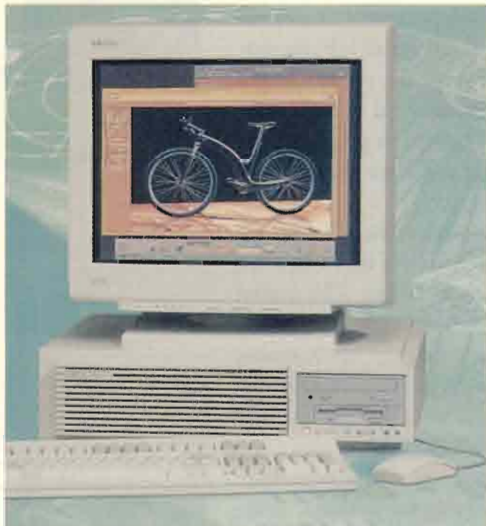

8000 CPU. The first C-class models (using HP's PA-7200 CPU), which were just introduced in November 1995, are upgradable to the PA-8000. And for a limited time, the C110 can be upgraded to a C160 for \$7,000. Not surprisingly, there is already an overwhelming demand for that upgrade. HP's J-class and K-class systems are also upgradable to the PA-8000.

The new HP PA-8000-based C-class workstations include two new PCI expansion slots, in addition to four GSC and three EISA slots. ●

YOU OUGHTA BE IN 3D PIXELS

But new PA-8000 boxes are not the only BIG announcement this month. In fact, during the introduction of the new PA-8000 C-class workstations, HP executives were more interested in talking up three new additions to HP's Visualize graphics subsystem series: the

Visualize EG, the Visualize IVX and the Visualize 48XP. With a growth rate of about 70 percent in 3D workstation sales (since 1991), who can blame them.

The Visualize EG is a 2D subsystem designed for 2D EDA and MDA applications. The Visualize IVX is a 2D subsystem for medical imaging, seismic processing, satellite interpretation and acoustical-data interpretation applications, whereas the Visualize 48XP is designed for sophisticated 3D CAE and CAD applications. Besides those products, the K260-EG and K460-EG (which includes the Visualize EG subsystem) and K460-XP (which includes the Visualize XP subsystem) also were introduced. Based on HP's four-way SMP K-class deskside systems, the K260-EG (\$62,245) and K460-EG (\$84,145) are expected to be useful in EDA simulations, and for GIS and other 2D applications.

The K460-XP (\$108,150) is expected to be useful in fluid dynamics, finite-element analysis, crash testing and other 3D applications. ●

A WINDOW OF OPPORTUNITY?

Add the Advanced Server/9000 (AS/9000) to HP's efforts to integrate Microsoft NT within HP-UX environments. In April, HP began shipping the AS/9000, an HP PA-RISC version of AT&T's Advanced Server for UNIX (AS/U). As a legal port of Windows NT 3.51 to UNIX, "it's the same thing as NT on top of HP-UX," says Sara Jacobsen, AS/9000 product manager. Essentially running as a UNIX application, the AS/9000 provides *file and print management* for small or enterprise networks.

Overall performance is as high as NT, claims Jacobsen, with about 85 percent of NT's performance for the file and print services. As for keeping

up with native NT upgrades, Jacobsen says "our goal is to keep it within a six month window." Because the AS/9000 provides NT domain controller and server support, as well as enhanced NT client and administration support (see below), users with HP's LAN Manager for UNIX, a similar product developed several years ago, should view the AS/9000 as the next upgrade path (migration tools are included). The AS/9000 can support up to 256 printers and queues, 700 print jobs, 1,024 users connected to a server, 1,900 files per AS/9000 directory to be replicated and 15,000 users per AS/9000 domain. Prices range from \$1,020 for an eight-user license to \$29,900 for a 1,024-user license. ●

DOING MORE WINDOWS

In yet another move toward integrating not only Windows NT but other PC environments like Novell NetWare servers and PC desktops with HP-UX, HP has introduced the IT Collaboration Program. Focusing on six areas — management, security/services, NOS/directory services, enterprise networking, messaging/groupware and distributed application access — the IT Collaboration Program "addresses customers' need to integrate mixed environments," according to Dick Watts, HP vice president and general manager of the Computer Systems Organization.

One major new product in the area of management is HP's OpenView IT/Administration (ITA) for Workgroups, a downsized and lower priced version of HP's OpenView IT/Administration, HP's enterprise system management software. "Our customers don't like the notion of having a separate management tool that's specific to one platform," says David Birnbaum, HP product manager. Intended for use by *part-time system administrators*, ITA

Don't play games with your memory.

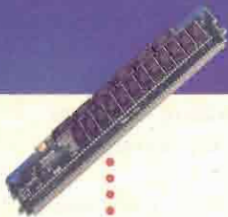
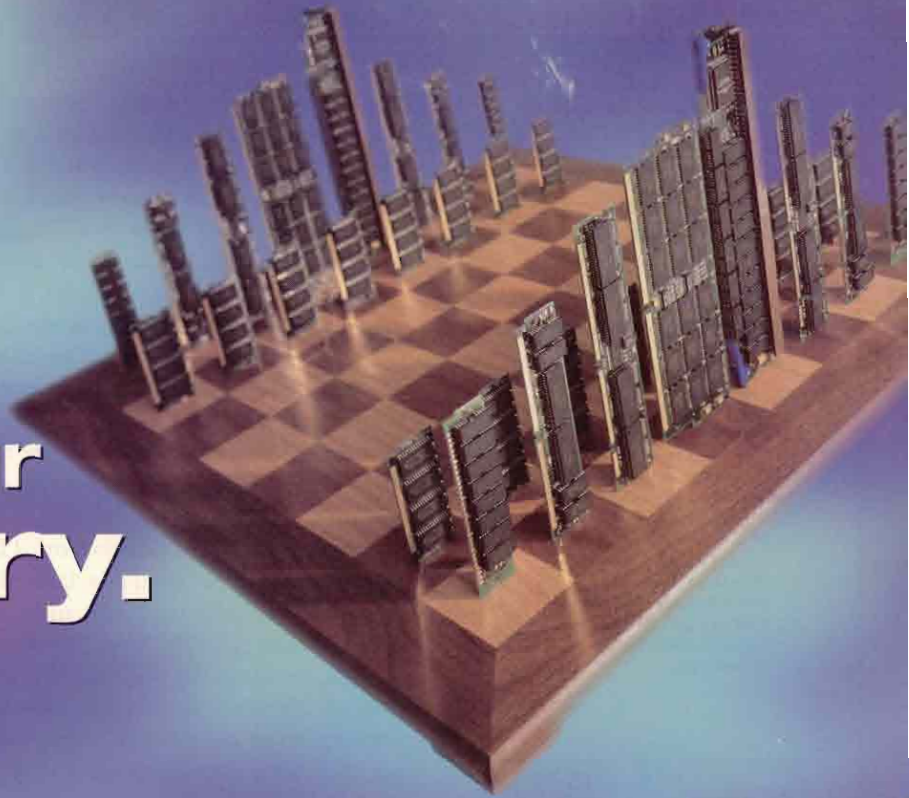

Simple Technology is a leading designer and manufacturer of memory upgrades, Flash and SRAM, and small form-factor memory cards. OEM sourcing and custom manufacturing is available.

Before you make a move for more memory, consider this.

Simple Technology uses the same components and technology that the leading workstation manufacturers use in their memory.

But at prices significantly lower than the manufacturers.

In addition, we don't use third-party subcontractors. This gives us the ability to monitor, test, and control every step of the assembly process in-house.

Every memory module is individually tested for durability and operation.

And every workstation module is tested in the actual workstation it was designed for, ensuring absolute 100% compatibility with your system.

So when you install Simple Technology memory you know it'll work the first time, and for a lifetime thereafter.

That's why so many leading computer

manufacturers and Fortune 500 companies have tested and endorsed our memory products for use in their systems.

We offer a complete line of workstation memory upgrades in standard configurations of up to 256MB.

And we keep your system on the leading edge with new advances in chip design. Like our revolutionary IC Tower® DRAM chip stacking technology which can pack 1GB of RAM on a single board.

To learn more about the memory that's right for you, call 1-800-474-6753.

And make your winning move with a Simple upgrade.

| | 16 | 32 | 64 | 128 | 256 |
|--------------------|----|----|----|-----|-----|
| HP 720, 730, 735 | ● | ● | ● | ● | ● |
| HP 705, 710 | ● | ● | | | |
| HP 712, E Class | ● | | | | |
| HP 715, 725 | ● | ● | ● | ● | ● |
| HP 750, 800 Series | ● | ● | ● | ● | ● |
| HP C, J, K Class | ● | ● | | | |

Call for our complete line of HP, Sun, IBM, Digital and Silicon Graphics workstation memory upgrades.

1-800-4-SIMPLE
7 4 6 7 5 3

<http://www.simpletech.com>

CIRCLE 261 ON READER CARD

simple
TECHNOLOGY

For instant information contact our fax-on-demand at 1-800-429-5626 x500

©1996 Simple Technology, Inc. All product names are trademarks of their respective companies. Simple Technology and the Simple Technology logo are trademarks of Simple Technology, Inc. International calls: (714) 474-1160. In Canada: 1-800-205-7866

THE
TOTAL
SOLUTION

sales, service, support

On-time service, on-line equipment. Black River takes the risk and worry out of ordering, implementation and maintenance.

You're assured:

- Full line of new and previously owned, refurbished 9000, 3000 and 1000.
 - Technically trained maintenance team.
 - Free installation
 - Nationwide service.
- Call 216-365-9950 or fax 216-365-3916 for more information.

BLACK RIVER
COMPUTERS
THE TOTAL SOLUTION
sales, service, support

7630 RACE ROAD • NORTH RIDGEVILLE, OHIO 44039
216-365-9950

CIRCLE 171 ON READER CARD

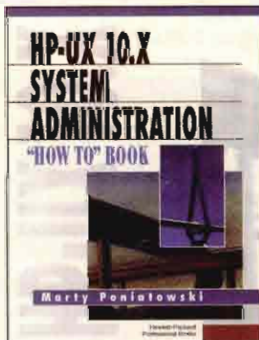

Learning
HP-UX
10.x is
now
Easy!

HP-UX 10.x SYSTEM ADMINISTRATION HOW-TO BOOK is the only HP-UX 10.x system administration book available. Author Marty Poniatowski—who wrote THE definitive source on HP-UX 9.0—applies the same successful “How-To” formula in this edition.

Contents include...

- HP-UX System Set-Up
- Networking
- System Administration Manager (SAM)
- Where Are Your HP-UX Resources Going?
- HP VUE and CDE
- Shell Programming for System Administrators

Don't miss this opportunity to learn HP-UX 10.x from THE expert.

call 1-800-285-1755 to order

CIRCLE 133 ON READER CARD

for Workgroups provides support for up to 250 nodes (desktop clients or servers) in a departmental workgroup. A part-time administrator “may not necessarily be part of the IS/IT organization, but might be one of 50 people who is tapped on the shoulder to be the administrator, especially in the case of regional offices,” explains Birnbaum. “There’s no network management capability included in ITA for Workgroups,” he stresses, “because we feel that is a more appropriate [task] for the IT organization.”

Besides software distribution, ITA for Workgroups (available later this summer) include: hardware and software inventory of PC Intel/Windows-based desktops as well as NT and Novell NetWare Servers, user/account management capabilities, change and configuration management of objects, file and print management, and a copy of HP OpenView OmniBack II for server backup and management. Supported servers include HP-UX (\$2,600), Novell NetWare 3.12 and 4.1 (\$2,600) and Novell NetWare for UNIX 3.12 (\$2,600). PC desktop agents (Windows, Windows 95 and Windows NT) cost \$95, with each one able to work with the ITA Workgroup product and the enterprise product.

However, while software distribution and hardware and software inventory are available for Microsoft NT Advanced Server 3.51, file and print management and user management *will not be available* until mid-1997 (see this month’s *Inner Networking* column). Likewise for HP’s newly announced Advanced Server/9000, none of ITA for Workgroups capabilities will be available until mid-1997. ●

HP RESTRUCTURES YET AGAIN

Early last month, proving that it can constantly reinvent itself with the best of them, HP has gone through another major corporate restructuring resulting in several organizational and management changes. The Computer Systems Organization (CSO), formed only last year under Rick Belluzzo, now has one new group, two new business units and one renamed business unit:

the Solutions Delivery Group (SDG) will handle customer interactions, channel management and solutions delivery for CSO products and services; the Commercial Systems Business Unit (CSBU) will focus on enterprise client-server and Internet/intranet computing solutions to support commercial applications; the Technical Computing Business Unit (TCBU) will focus on workstations, graphics, massively parallel computers, X terminals and system peripherals for the technical marketplace; and the Enterprise Middleware Business Unit (EMBU), formerly known as the Software Business Unit, will work with HP partners to develop a critical set of enterprise middleware.

The Systems Technology Group (STG) under Rich Sevcik, HP vice president and general manager, and the Order Fulfillment Group (OFG), under Richard S. Love, HP vice president and general manager, both of which are also a part of the CSO, remain unchanged.

Persons appointed to lead the new groups include Manuel F. Diaz (the SDG), formerly general manager of CSO’s Worldwide Sales and Marketing Organization; Glenn R. Osaka (the CSBU), formerly general manager of the Professional Services Organization; William V. Russell (the TCBU), former general manager of CSO Europe; Tilman Schad (the EMBU) formerly general manager of the Software Business Unit, will remain as such with the newly renamed unit. ●

CAN YOU SAY INTERNET?

HP sure can. Since the introduction of its Internet strategy this past December, Internet announcements from HP have come at a fast and furious pace — from services to products to new Web sites. Too fast, in fact, to report and analyze them all in this space. But while we digest it all — here’s a brief sampling to keep you up-to-date:

Internet Consulting Services.

HP’s Internet Consulting Service is now available from HP’s Professional Services Organization (PSO). Formed in July of last year for early adopters and Internet trailblazers, the service is

now being offered for anyone working "inside or outside the firewall," according to Paul Klouda, HP's Americas Internet Consulting Practice manager. HP's Internet Consulting Practice currently offers a portfolio of services that enable customers to implement entire solutions or to integrate new Internet solutions into existing networks. Klouda claims to be able to get 80 percent functionality of an application (on an agreed upon prototype) up and running in three weeks. The practice is predicated on HP's own experience with building its own internal intranet /Internet network.

New HP Web Site. A new HP Web site (www.software.hp.com) provides free-of-charge access to popular applications for HP-UX and to the latest software drivers, patches and utilities for all HP equipment, as well as problem-solving databases and support news. Links to non-HP Internet sites also are available.

Internet Collaboration Services.

An extension of HP OpenMail's messaging and infrastructure and interfaces to the Internet, HP's Internet Collaboration Services will provide any OpenMail user with a Web browser to communicate over the Internet using e-mail, calendaring/scheduling, conferencing and shared folders.

Internet Security. The first in a line of HP Internet security products, the Praesidium Authorization Server (\$30,000 to \$50,000 per server) makes it possible to assign specific access privileges to each and every user within an intranet, private network or any distributed computing environments. Clients accessing the Praesidium server can run HP-UX 10.01, Windows NT 3.5 or Windows 3.11. Application servers authorized by Praesidium can run HP-UX 10.01 or Windows NT 3.51.

OpenWarehouse Web Initiative. The HP OpenWarehouse Web Initiative is a program that provides secure Web browser access to data warehouses via a new Web-enabled version of

HP's Intelligent Warehouse management software (available in May). It now includes a B1 security Web server platform and an initial set of nine Web-based applications. In addition, the program includes consulting services from HP's PSO.

Broadband Internet Delivery System. Announced during the National Cable Television Association Convention (Las Vegas, Nev.) in April, HP's Broadband Internet Delivery System is an end-to-end system using cable modems which have 1,000 times the capacity of standard dial-up telephone lines and Netscape Server software to deliver data to PCs. Because the end-to-end system works with existing residential cable and telecommunications infrastructures, cable companies, telcos and utility providers can use it to bring Internet access and interactive services to their subscribers. ●

Before It Hits, Call WTW.

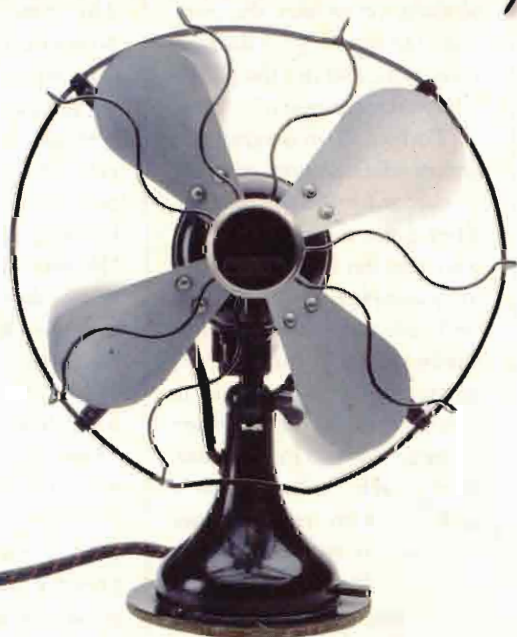

We've all been there. And before it hits, let WTW help. We're an internationally recognized information technology consulting and systems integration firm specializing in staff extension and custom project development. Our proven track record has helped forward-looking companies stay one step ahead. As your technology partner, we'll deliver customized solutions *before*...well, you know.



WESSON, TAYLOR, WELLS
& ASSOCIATES, INC.

800.833.2894

STAFF EXTENSION SERVICES • SYSTEMS INTEGRATION • COMPUTER TELEPHONY • APPLICATION DEVELOPMENT

Atlanta

Charlotte

KTP, NC

Philadelphia

Phoenix

CIRCLE 201 ON READER CARD

With The Fondest Of Memories

People Power Has Given Kingston Technology The Culture To Make Memories Happen



"Anyone can do what we do. Now that we have grown, our challenge is to preserve the culture that has made us who we are."

David Sun
Vice President of
Engineering
Kingston
Technology Corp.

Kingston Technology Corp. (Fountain Valley, Calif.) is to computer memory what Intel is to the processor. It dominates the memory market like no other vendor, and continued growth for Kingston seems inevitable.

Co-owners John Tu and David Sun launched Kingston in 1987, when the memory market was ready to explode. At that time, the computer industry faced a supply shortage of memory modules for PCs. Kingston's solution to the shortage was to design an industry-standard Single In-line Memory Module (SIMM) using an alternative chip that was more readily available. Soon thereafter, Kingston began developing memory products for a variety of PCs, including those from IBM and Compaq that employed proprietary memory module designs. In their first full year, Kingston earned sales of nearly \$13 million.

"We built Kingston on mutual respect," explains Sun, Kingston co-founder and vice president of engineering. "John and I think alike and have the same values. We always put ourselves in the other guy's shoes before we act."

Just one year after its auspicious beginning, chips became readily available in the indus-

try and memory products grew plentiful as other computer vendors such as Viking Components (Laguna Hills, Calif.) and Simple Technology (Santa Ana, Calif.) followed Kingston into the memory components arena. Still, Kingston maintained its market lead, thanks to a loyal customer base and a reputation for reliable products.

Tu and Sun stressed an ideology that employees should be regarded as valued family members and take priority over vendors and suppliers, and even customers. "Without your employees and your vendors, you have no customer," says Sun. "It's so obvious, yet so often the company focus is only on financial statements, and not the people who make it happen."

Today, IS managers and system administrators continue to clamor for lots of memory. They point to computer software that has become increasingly complex, keeping in step with advances in computer hardware technology. Programs have grown not just in terms of the functions they perform, but also in sheer size. And each new version of PC software requires more memory to make it run. A year ago, for example, users were using operating systems with a standard memory of between 16 MB and 64 MB,

with an average of 48 MB. With the release of Windows NT and HP-UX 10, and the subsequent increases in demand from applications and systems, standard memory requirements have risen to well over 64 MB.

Soon after the introduction of Kingston's first memory product, the company began shipping storage subsystems, a line of products that has grown to include Data Express removable disk systems, and Data Silo, a family of SCSI interface storage subsystems.

Today Kingston maintains a portfolio of 1,600 products — memory and non-memory. The company earned the Number 1 position on *Inc.* magazine's list of fastest-growing private companies in 1992, with sales of \$251 million. Last year, sales were \$1.3 billion and projections for 1996 are hovering around \$2.1 billion. "Business should be based on relationships, not just the bottom line. We have long-term relationships with our vendors and we can do business on a handshake," remarks Sun. "Anyone can do what we do, it's our people that make the difference. Now that we have grown, our challenge is to preserve the culture that has made us who we are."

Kingston Technology

17600 Newhope St.
Fountain Valley, CA 92708
Tel: (800) 337-8410
fax: (714) 435-2899
www.kingston.com

CIRCLE 356 ON READER CARD

Highest performance PC X Server.
Fully X11R6.1 compliant and the
fastest on the market today.

New! IRC Client. Allows you to participate in real time on-line discussions across the Internet with multiple participants.

Xtrace Protocol Tracer. Captures X network protocol for greatly simplified troubleshooting and application debugging.

Hummingbird Basic Scripting Language. For customizing applications and automating repetitive tasks.

New! Improved Telnet. Support for up to VT320 and Wyse 50, Wyse 60, ANSI, SCO ANSI emulations. DDE server / OLE automation.

Unique Launch Pad and Virtual Desktop. User-programmable menuing facility with graphical interface simplifies window management and application launching.

Enhanced Xpress Serial Line Access. Takes advantage of modem compression capabilities.

Unique full-featured X Development Kit. Lets you port, design and run X clients right on the PC.

Graphical Keyboard Configurator. Enables simple remapping of keys and key sequences.

Reconfig and Sconfig. Even more powerful centralized network administration, configuration and installation facilities.

New! Columbus Lite. Integrated Internet Access Tools including Web Browser, E-Mail, NetBook, News, FTP and Gopher.

Xsession Drag-and-Drop Multiple Program Starter. For concurrent startup of X, non-X, and Windows applications.

NFS client. For seamless sharing of network resources.

New! Open GL for X Windows System for 3D Graphics. (Available as an option for Windows NT.)

PPP and SLIP support. Provides IP over serial line connectivity.

New! MiniViewer. For viewing portable electronic documents in DigitalPaper format.

Hummingbird VxD TCP/IP stack, plus Microsoft's TCP/IP stack. Both support NFS and associated utilities.

New! TN5250 & TN3270. Provides IBM terminal emulation.

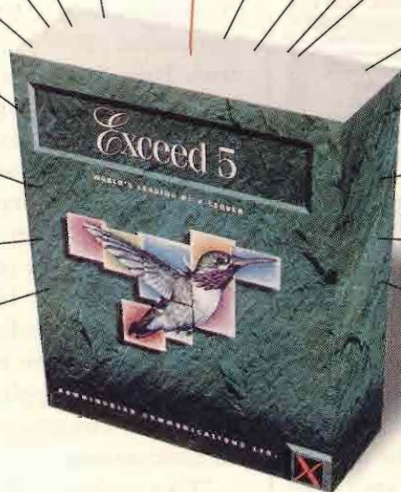

We Just Exceeded Exceed. Again.

Announcing Exceed 5.1 from Hummingbird.

X Great News - Exceed users worldwide will soon be upgraded to Exceed 5.1. Which means the world's best PC X server will serve them better.

Exceed 5.1 still features everything you need for robust PC-to-UNIX integration, including the fastest, most stable PC X server on the market. Along with powerful administration and installation tools that make every network administrator's job easier. Plus our extensive set of internetworking tools,

like NFS and TCP/IP. And now, the upgraded Exceed 5.1 gives you the best Telnet available, an IRC client, TAR and even Columbus Lite, Hummingbird's integrated Internet access system.

Now you can count yourself among the hundreds of thousands of satisfied Exceed users worldwide. Get Exceed 5.1. For more information or the name of the reseller serving you, call (416) 496-2200.

Available for Windows, Windows NT & Windows 95.



HUMMINGBIRD
COMMUNICATIONS LTD.

www.hummingbird.com

CIRCLE 156 ON READER CARD

Forte's Express Development Route

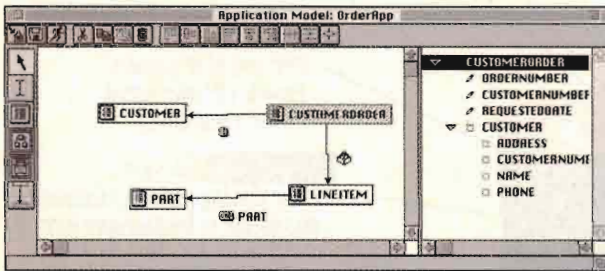

FORTE EXPRESS

- Generates default user interface window definitions
- Creates interfaces to Oracle, Sybase, Informix Online, Microsoft SQL Server, Rdb, IBM DB2/6000 and Microsoft's ODBC
- \$20,000 for a 10-user site license

Forte Software Inc.

1800 Harrison St.
Oakland, CA 94614
tel: (510) 869-3400
fax: (510) 869-3480
info@forte.com
www.forte.com

CIRCLE 355 ON READER CARD

Amisys Managed Care Systems (Rockville, Md.) develops software covering all the aspects of managed healthcare companies — membership management, providers, benefits, fee scheduling and claims processing. The software currently runs only on HP 3000 systems. But because Amisys feels that client-server technology is now capable enough for enterprisewide applications, they've decided to port the software to most major UNIX platforms (including HP-UX), according to Mike Shaffer, director of technology/development at Amisys. The underlying architecture will be on HP-UX, as well as some on IBM AIX, but the product will also support the other UNIX platforms.

Because Shaffer has lots of legacy COBOL code to migrate, he was looking for a development product that

wouldn't require any initial re-engineering. So, in September 1995, Shaffer chose Forte Software's (Oakland, Calif.) Forte Application Environment, an integrated set of object-oriented tools for building, deploying and managing client-server applications, as his primary development tool. He also implemented Forte Express, an optional software module that is a visual application generator, complementing the environment.

"Our primary concern was that the product we choose supported a three-tier or multi-tier architecture, because for enterprise applications, that is the way to go," says Shaffer. Forte Express generates the user interface and database access components of well-architected, object-oriented multi-tier applications for hundreds to thousands of users.

Forte Express generates default user interface window definitions that include window layouts, menus and buttons. "Forte Express enforces a solid architectural structure and a modeling concept," explains Shaffer. "You just have to worry about customization." It supports different interaction styles — master-detail, window-per-second and tab-style windows

— that use native Windows, Macintosh and Motif interfaces when the application is deployed.

Building a Forte Express application requires importing the database schema, defining basic objects that constitute the business model, defining the application model and generating the application. The generation process creates standard Forte class libraries, which may be customized.

Forte Express creates database interfaces to Oracle, Sybase, Informix Online, Microsoft SQL Server, Rdb and IBM DB2/6000, as well as Microsoft's ODBC.

Supported client platforms include: Microsoft Windows and Windows 95, Apple MacOS and OSF Motif. Supported servers include: HP-UX, Digital OpenVMS (VAX and Alpha), Digital UNIX, Data General AViiON DGUX, IBM AIX, Microsoft Windows NT (on Intel and Alpha), Sequent Dynix and Sun Solaris.

Price is \$20,000 for a 10-user site license.

—Deborah Schwartz,
Associate Editor

PNY LOADS HP WORKSTATION MEMORY WITH THE WORKS:

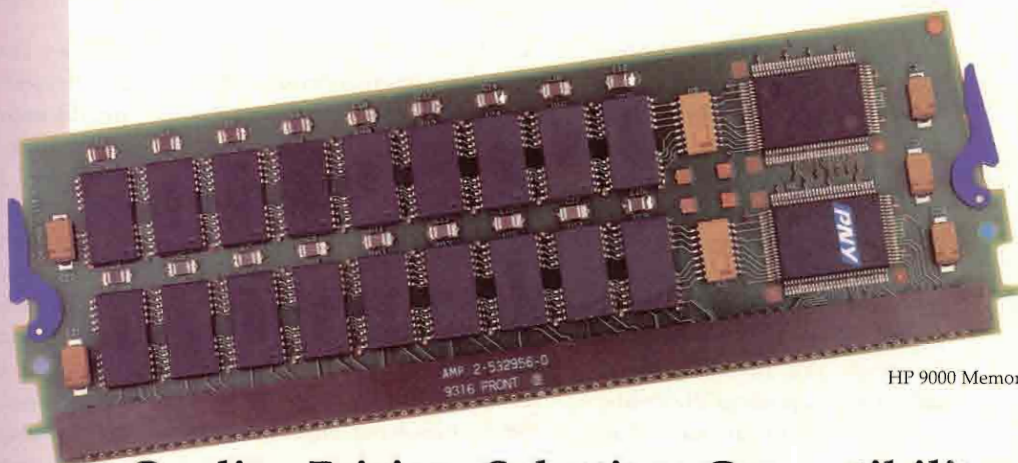

HP 9000 Memory

Quality, Pricing, Selection, Compatibility, Support and Service

PNY manufactures every memory module in-house to ISO9001 standards. When it comes to your bottom line, PNY prices are among the lowest in the industry. Searching for selection? PNY's product availability is second to none. That's because PNY is the world's largest producer of standard memory modules. PNY also creates flawless customized configurations. Simply dial 1-800-234-4597 to speak to a trained PNY tech support rep to access the PNY Fax-Back Service for instant product information. Add to this a full lifetime warranty, 24 hour delivery and you'll see why PNY wrote the book on service. So, if you're going to buy more memory for your HP workstation, shouldn't you get it with the **works?**



SUN X132M

HEWLETT PACKARD WORKSTATIONS

| Workstation Model | Upgrade | | | | |
|---|---------|-------|------|-------|-------|
| HP 9000 700/RX stations, ENVIZEX, ENTRIA | 2MB | 4M | 8MB | 16MB | 32MB |
| HP 9000 700 Series | 8MB | 16MB | 32MB | 64MB | 128MB |
| HP 9000 8X7, E, G, H, L, Series | 16MB | 32MB | 64MB | 128MB | |
| HP 9000 J, K, Series | 32MB | 128MB | | | |
| HP 3000 9X7 Series | 16MB | 32MB | 64MB | 128MB | |
| And many more.... | | | | | |

To find out more about PNY workstation products, call 1-800-769-0142

Corporate Headquarters:
PNY Electronics, Inc, 200 Anderson
Avenue, Moonachie, NJ 07074
Tel:201-438-6300 Fax: 201-438-9097

Midwest Regional Headquarters:
1162 Penarth Court, Commerce, MI
48382 Tel: 810-360-2750

Southern Regional Headquarters:
5616 Belle Chasse Frisco, TX 75034
Tel: 214-335-9010

Western Regional Headquarters:
1 Venture, Suite 240, Irvine, CA
92718 Tel: 714-727-3610

European Headquarters:
Rue J. Cugnot, Zac du Phare-bp 181,
33708 Merignac Cedex, France
Tel: 011 3356-13-75-75

Munich Sales Office:
Dianastr. 20, 85540 Haar, Germany
Tel: 011 4989-460-5914



PNY
"The Memory Leader...Worldwide."

From Art To Part, RKS Design Has Got The Look That Works For You

We all know that first impressions can sometimes make or break relationships. On a more subtle basis, it's the same for the products we purchase. "Visual positioning plays a critical role in consumer purchasing," explains Ravi K. Sawhney, president and founder of RKS Design (Canoga Park, Calif.). "People look at products and instantly make judgments regarding durability, reliability and functionality. Part of a good design is creating a positive first impression."

You're probably not familiar with RKS Design, but their influence goes a long way. Sawhney and RKS have mastered the art of first impressions and have impressed clients and consumers with their product design work. If you've seen the Teddy Ruxpin animated talking bear, or used an Ascii Entertainment Sega-compatible video game controller, a hand-held oxygen sensor or a notebook computer, you're familiar with their work.

RKS is able to pull it all together — looks and functionality — by performing 3D solid modeling with HP's ME30 solid modeling software and HP's Precision Engineering (PE)/SolidDesigner software. "Clients don't come to us because they want something that looks good," says Sawhney, who began the company in his parent's garage. "You can design something that looks outstanding, but it may be impossible to manufacture or cost-prohibitive to produce. So when we speak of providing

'marketing and manufacturing advantages through design,' we're emphasizing that throughout the design process, manufacturing costs and the product's marketability are at the forefront of everything we do.

DETAILS, DETAILS, DETAILS

The 14-year-old RKS pools the abilities of 14 full-time designers, one mechanical engineer and three consulting engineers, to combine technology, ergonomics, marketing, manufacturing and design with an understanding of a client's requirements. "When you're developing an entirely new product, no detail is too small, no function unimportant,"

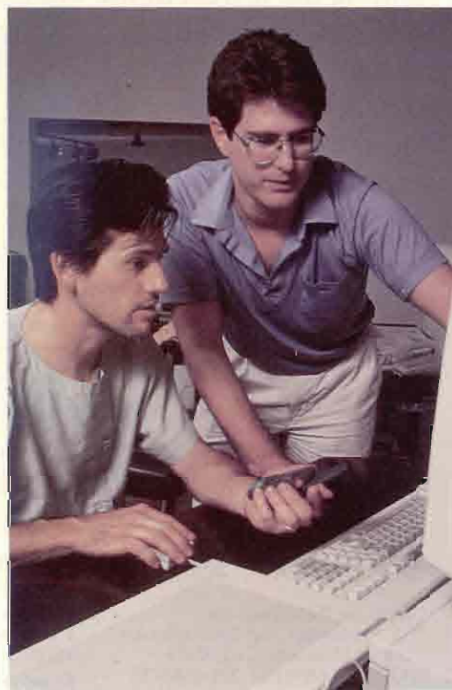

Designers Lance Hussey and Kurt Botsai review a prototype of a new electronic game on an HP 9000 workstation.

Sawhney continues. "'Working' goes beyond meeting a technical specification. To us, working means 'I can play for a couple of hours, and it feels right in my hands.' Those kinds of intangibles you can't write into the specification. But when you incorporate them, it gives your client a marketing advantage."

Product design is a series of compromises affected by market forces, competition and changing consumer tastes, all of which determine how fast a product goes from concept to point-of-purchase. It's a delicate balance. Push the process too quickly and you risk manufacturing an incomplete or poorly designed

product. Move too slowly and you risk losing your market share. The ability to compress the design process is one of the reasons RKS moved full-force into 3D solid modeling. According to Sawhney, the HP software allows RKS to develop mechanical models of all the internal components and constraints prior to design studies.

MODELING MADE EASY

The company also uses HP's ME10 for 2D design and the output of full-production drawings. Running on four 735s, two 730s and one X terminal, the solid modeling tools improve

The benefits of rightsizing

are nothing short of miraculous.

But if you forgot about

production printing, you're going to need

a miracle

just to print statements or invoices.



Thankfully, miracles do happen. Xerox, the leader in production laser printing, and Hewlett-Packard, the leader in UNIX business servers, have joined forces to give HP 9000 users direct access to Xerox' family of 50+ ppm laser printers for enterprise-wide distributed production print solutions. So relax. Because now you can print your mission-critical documents where you need them, when you need them. With quality, speeds and reliability to meet your most demanding print applications. All backed by both companies' outstanding service and support. To learn more, call us at 1-800-ASK XEROX (ext.250). It's everything you've been wishing for.

THE DOCUMENT COMPANY
XEROX

 **HEWLETT®
PACKARD**
CIRCLE 183 ON READER CARD

Do You Have One UPS, A Bunch Of UNIX Servers, And A Burning Desire For Advanced Power Management?

Looking to Avoid Buying Multiple UPS's for Multiple Servers?

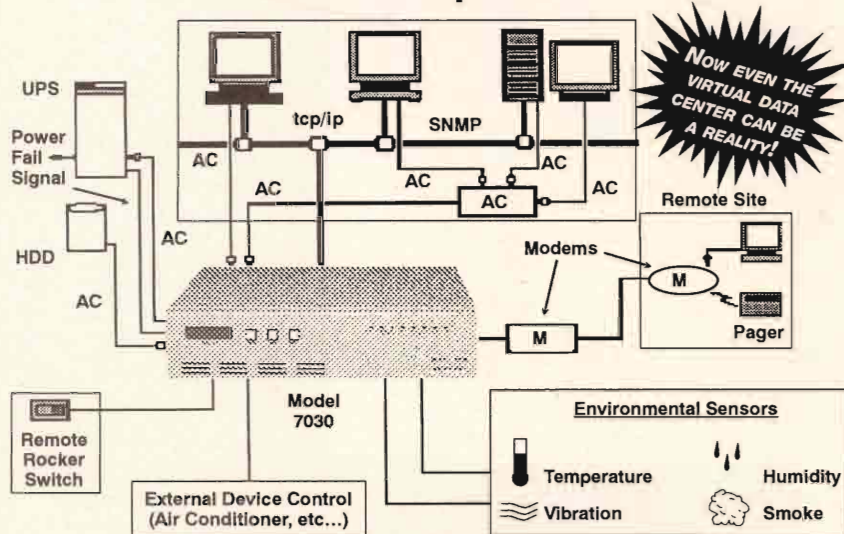

Save Money With Texas ISA's Ultimate UNIX Power Management Solution!

FEATURES

- ◆ Automatically applies and removes AC power to networked computers and peripherals using one UPS
- ◆ Gracefully shuts down and starts up computers using:
 - ◆ Attached Rocker Switch
 - ◆ Programmable Timers
 - ◆ Environmental Sensors
 - ◆ UPS Power Fail Signal
 - ◆ Local or Remote Console
- ◆ Connects through serial or LAN port
- ◆ Notifies remote system or pager of abnormal conditions
- ◆ Digital inputs and outputs to monitor external devices
- ◆ Supports TCP/IP and SNMP

BENEFITS

- ★ Protects the OS and data from being corrupted
- ★ Increases computer and peripheral life expectancy
- ★ Helps UNIX managers conform to the EPA Energy Star program
- ★ Secures the startup/shutdown procedure against unauthorized access
- ★ Eases local and remote systems management
- ★ Eliminates unnecessary travel time to reboot remote systems
- ★ Facilitates large scale distributed computing power-downs and power-ups
- ★ Makes the virtual data center a reality

Call Texas ISA today for your FREE 30 day trial. It's simple to install.

800-361-2258 • 713-493-9925

info@texasisa.com • Website: <http://www.texasisa.com>

CIRCLE 127 ON READER CARD



RKS' ability to respond to tight time constraints no matter what the project's complexity or sophistication. Projects that would have taken eight to 10 weeks, can now be completed in less than three — including producing prototype parts. "We're able to do parallel design for manufacturing. We can bounce between concept and 3D modeling," says Sawhney.

HP's Precision Engineering (PE) ME10 is a 2D design, drafting and documentation system. Based on the original ME10, it features a user guidance system for fast accurate specifications of geometry, the capability to capture inherent geometric relationships, and the ability to ensure automatic and precise updates of all relevant aspects of a drawing when geometry is modified. The HP ME30 is an integrated modeling, design and drafting system. It provides a smooth progression from 2D to 3D modeling. ME30 software can be used for: visual evaluation of overall design and of individual part relationships; reduction of lengthy physical prototyping cycles; geometric and physical analysis of solid parts and assemblies; and generation of complete two-dimensional documentation, including section view.

The ME30 user interface consists of major commands on tablet menu fields, sub-menus on the screen, self-explanatory prompts, on-screen HELP on the use of any command and an UNDO command to return the geometry to its original state. "Solid modeling allows for a higher level of visualization," Sawhney says. "It increases interaction between companies working on different components of the same product. Because it's three-dimensional and can be rotated, it virtually ends questions of interpretation."

RKS, formerly users of AutoCAD and MicroCADAM, started using HP's ME10 and ME30 software about 4 years ago. "The marketplace demands higher quality products that look softer and smoother — more user-friendly," says Frank Zinni, design director. "You can do that three-dimensionally on a computer screen with PE/SolidDesigner. You can get the soft,

"Cardinal Business Media Sets Its 'Sites' On The Future!"

Cardinal Business Media, Inc., a leader in high-tech publishing, can now be seen on the World Wide Web! Visit all of Cardinal's high-tech publications with just one click...

<http://www.btb.com/cardinal>

Cardinal's Web Site Features...

- CBM Books
- Digital Age
- ENT
- Enterprise Systems Journal
- HP Professional
- Imaging World
- INTERNETWORK
- MIDRANGE Systems
- Unisphere Magazine

well-refined surfaces consumers now seek. You can check designs for fit and function — things you previously could only do by actually building a model. Before we had this technology,

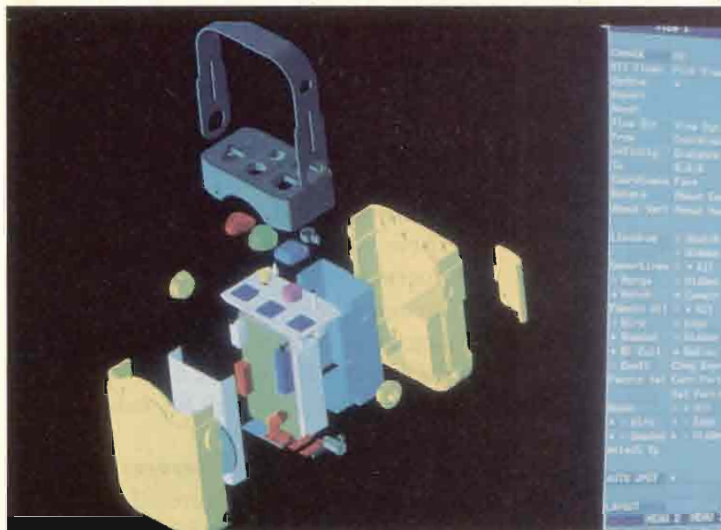

An exploded view of a portable safety monitor for hazardous environments that was created using HP's ME30 solid modeling software.

we spent time and energy interpreting the information and projecting views. Now that's all incidental."

THE PROOF IS IN THE PROJECTS

About 3 years ago, L.A. Gear assigned RKS to design an LED (light-emitting diode) keychain casing to be given away as part of L.A. Gear's promotion of its new "footwear technology." Drafting a complex part used to take several weeks. With PE/SolidDesigner, however, the process can take days. "We had a super accelerated time to market," Sawhney says. With the L.A. Gear project it was only four weeks from the initial concept until the production product was coming off the assembly line. Another project, last year, involved designing high-end stereo speakers for JVL (Van Nuys, Calif.). According to Sawhney, once again the ME30 software provided the functionality to bring about a quick turn around. "It only took 12 weeks from art to part."

Most RKS clients are companies that have developed new technologies and now need help packaging that technology into a product. Once RKS

accepts a project, the company's designers get together and review the requirements. The group brainstorms to get the maximum perspective and viewpoints on a particular problem.

Then Sawhney and Zinni, who between them have more than 45 years of design experience, designate two or three people as the responsible design team — which can call on any other designers in the office at a moment's notice to focus on a par-



A Sega-compatible video game controller designed by RKS for Ascii Entertainment.

ticular problem.

"Because we're a small company, Frank and I work directly on projects. And I think our clients appreciate that direct involvement," Sawhney says. In a larger firm, he notes that "we would be involved strictly in management." Besides, Sawhney is happy to do what he loves — to design. But now, he stresses, "just because RKS has become successful, it doesn't mean I have to give that up."

—Deborah Schwartz,
Associate Editor

*For client/server
computing,
hire a staff of 50,
spend \$1 million,
and rewrite all
your legacy
applications.*



Or not.

NetBase® Client

NetBase Client is a simple, straightforward client/server solution that:

~ Provides access to HP 3000 MPE or KSAM files and TurboIMAGE from UNIX, DOS and Windows.

~ Makes existing legacy data accessible from PC and UNIX applications without remote logons, expensive HP user licenses or unnecessary application changes.

~ Can be quickly and inexpensively implemented in a tightly-integrated HP 3000 environment.

Phone: 714-720-1434, e-mail: info@quests.com.
All names are registered trademarks or trademarks of their owners.

**QUEST
SOFTWARE**
Expect a solution.

All

Worked

A Snapshot Of The HP

Computer System Product Line

UP

THE HP COMPUTER SYSTEM product line changes so fast that every so often it is helpful to get a snapshot of what is current. Every issue of *HP Professional* has several announcements. Positioning these announcements within an existing line of products and trying to see the big picture is sometimes difficult. Because I have the advantage of discussing the HP computer product line on a regular basis with HP customers, I keep up-to-date on most HP products. The following sections of this article provide a quick and easy overview of some of the most important parts of the HP computer product line. I will caution you, however, that between the time I write this in early April and you read it in June there have probably been several additional announcements made.

Editor's Note: It has happened already. Check out this month's Industry Watch for two new HP workstations.

PARALLEL PROCESSING SERVERS

WHAT IS GOING on with parallel processors? Does HP have parallel processors? Which parallel processor is good for which job? These are some of the questions I am asked on a regular basis. Let me take just one minute and talk about parallel processing, the most misunderstood part of the computer industry.

Before you consider which parallel processor is best, consider which of the two types of jobs you have:

- 1) Single Task Job — This is one big job. As the job gets bigger, all computing resources are focused on getting this job to run faster.
- 2) Multi-Task Jobs — Many tasks need to be completed that can be done in parallel. As additional tasks are added, you need more performance to complete these additional tasks.

Now let's look at the four parallel computing solutions HP offers.

Symmetric Multi-Processing (SMP)

These are systems in which several processors share memory and I/O. One instance of the operating system is running on an SMP system. The HP 9000 T-Class and K-Class are SMP systems. SMP systems scale well for most types of jobs.

Enterprise Parallel Servers (EPS)

The parallel architecture of the HP 9000 EPS (EPS20, EPS21 and EPS30) uses high-performance SMP technology as scalable building blocks. The EPS is designed to scale at near linear performance for most applications. This is achieved by using the inherent high-performance SMP bus architecture of the EPS nodes, and then grouping them via a high-speed interconnect into a single computational resource. *Figure 1* shows the EPS architecture.

Clusters

These are multiple independent systems. Each system has its own CPU, memory and I/O. Each system in the cluster has its own copy of the operating system. The systems within the cluster can be SMP systems. The systems typically communicate over a high-speed LAN. The HP MPS10 is a cluster.

Clusters work well for general purpose transaction processing and other applications.

Massively Parallel Processing (MPP)

This can consist of hundreds of processing units. Each consists of a CPU and memory, and sometimes I/O. The interconnection between MPP is web-like and ultra-high speed. The HP Convex SPP1000 is MPP and supports 128 PA-RISC processors. *Figure 2* shows a simplified diagram of the SPP1000.

M a r t y P o n i a t o w s k i

MPP works well for compute-intensive, highly-parallel applications.

HP 9000 SERVERS AND WORKSTATIONS

WHEN WRITING articles like these in the past, I would always break out servers and workstations into two different groups. Is there a reason to do this? The answer is no. Both the servers and workstations are based on PA-RISC. With the release of HP-UX 10.x, the operating system running on both is nearly identical. Because the servers and workstations are binary compatible, there is no reason to make these into two different groupings. There are still some differences between the two, such as high-end graphics supported on the workstations and high availability features supported on the servers; however, this is one line of products. Figure 3 shows the HP 9000 product line.

A term that I think was overused for some time is "scalability." Any computer line that had one system that was faster than another was termed "scalable." The systems shown in Figure 3, however, represent true scalability. I

have first-hand experience working with installations that perform software development on entry-level workstations for target systems that are T-Class.

A POPULAR FOUNDATION

THE ARCHITECTURE on which a computer is based is certainly at a low level in the grand scheme of things. Yet, it is amazing how much attention it receives. Very few low-level technologies are important to computer system buyers, but the architecture certainly does manage to be the source of many a headline.

HP's success over the last several years is based part on the performance and scalability (there's that word again) of PA-RISC. But the most interesting part of PA-RISC is the future. Two significant developments are taking place:

- 1) The continued improvement of PA-RISC in products such as the upcoming PA-8000 (see sidebar).
- 2) The joint development of an architecture between HP and Intel.

Even with the substantial performance increases of the PA-8000 right around the corner, you can't help but

FIGURE 1

HP 9000 ENTERPRISE PARALLEL SERVER HIGHLY PARALLEL PROCESSING

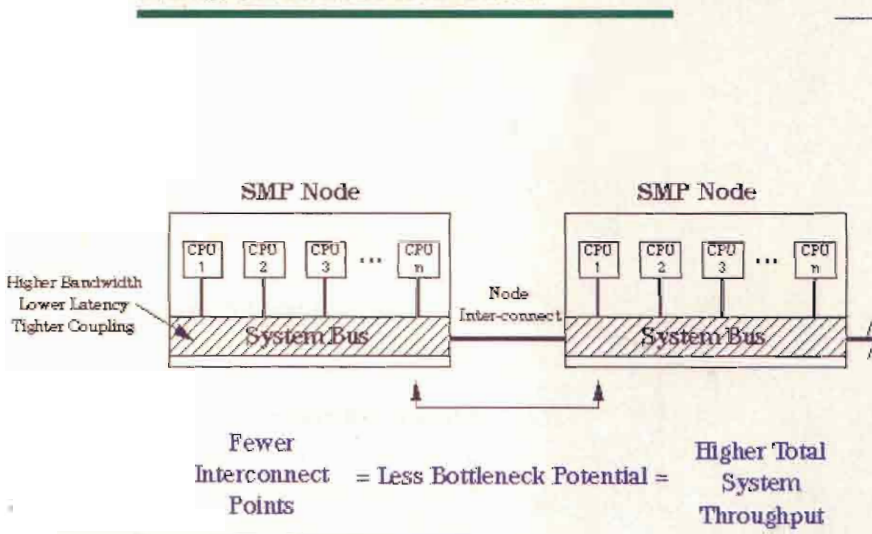

The Enterprise Parallel Server architecture.

To protect your
data, you
could back-up
hourly, buy a
fire-proof safe,
and a \$5 million
insurance policy.



Or not.

NetBase

NetBase is a comprehensive disaster recovery and clustering solution that:

- ~ Creates a fault-tolerant network integrating MPE, UNIX and desktop systems.
- ~ Improves performance and maximizes system availability.
- ~ Optimizes workloads by distributing processes and data on the network.
- ~ Provides industrial strength disaster tolerance without the need to change applications.
- ~ Improves system management through file and user statistics for any node.
- ~ Protects investments by allowing modular growth.

Phone: 714-720-1434, e-mail: info@quests.com.

All names are registered trademarks or trademarks of their owners.

**QUEST
SOFTWARE**
Expect a solution.

CIRCLE 483 ON READER CARD

With
Unison RoadRunner
your UNIX backups won't encounter any
speed bumps

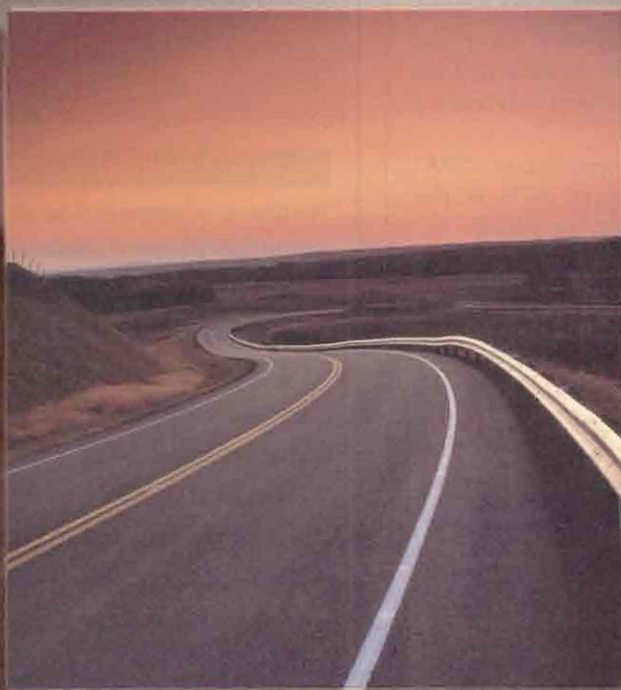

That's because Unison RoadRunner is the fastest and most reliable backup product you can buy for your UNIX systems. It provides high-speed, high-compression store and restore, with speeds of more than 60 gigabytes per hour on parallel drives.

That makes RoadRunner the ideal solution for environments that include large servers with large amounts of data to be backed up. And companies have peace of mind because they know that in a disaster situation their mission-critical data will be restored quickly and reliably.

But RoadRunner gives you much more than high speed. Support for multiple platforms means RoadRunner can handle all backup and recovery requirements across the network. And RoadRunner gives you the option of using a point-and-click GUI or a feature-rich command-line interface.

There's a lot more. A state-of-the-art catalog management system. Extensive device support. On-line backup of Oracle and Sybase databases. Integration with HP's Operations-Center. You can even custom-tune certain backup parameters to achieve optimal performance.

Whichever way you run it, RoadRunner gives you the record-setting performance that sets it apart from all competitors. See for yourself. Call us today at **1-800/298-4149** for more information.

Unison Software

5101 Patrick Henry Dr., Santa Clara, CA 95054
Phone 1-800/298-4149, Fax 408/988-2236
Web Site <http://www.unison.com>

CIRCLE 499 ON READER CARD

All Worked Up

be intrigued by the prospect of binary compatibility with both PA-RISC and Intel's X86 architectures.

STORAGE SURPRISES

I HAVE NOT BEEN known to write about disks a lot in the past. I'm mostly interested in processors and operating systems. Recently, however, with some advancements on the storage

front, this has become an area of increasing interest to the HP community and one that provides some interesting technical options. The high availability (HA) storage solutions from HP include high reliability disk drives, HA storage systems with hot-plug disks and software mirroring, an HA disk array with optimal fault resilience and performance, and Symmetrix 3000 with mainframe-class availability,

(continued on page 26)

FIGURE 2

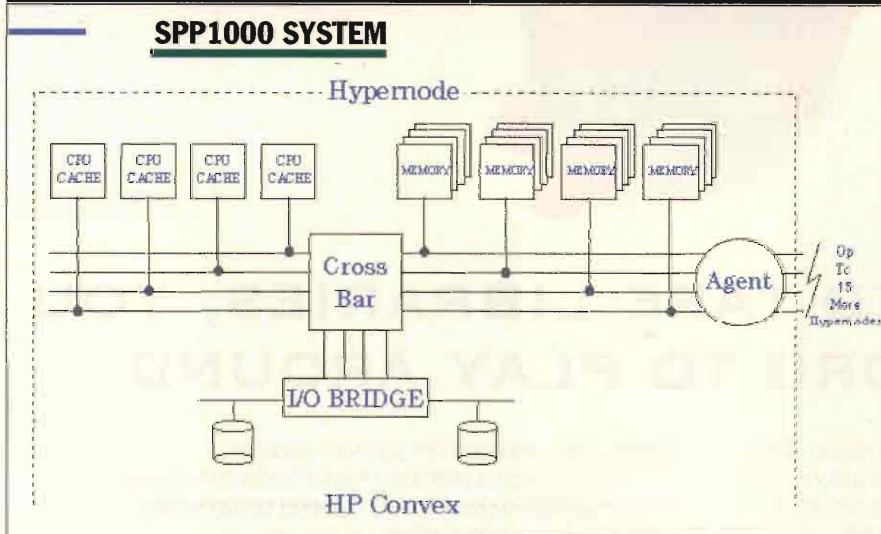

The SPP1000 System

FIGURE 3

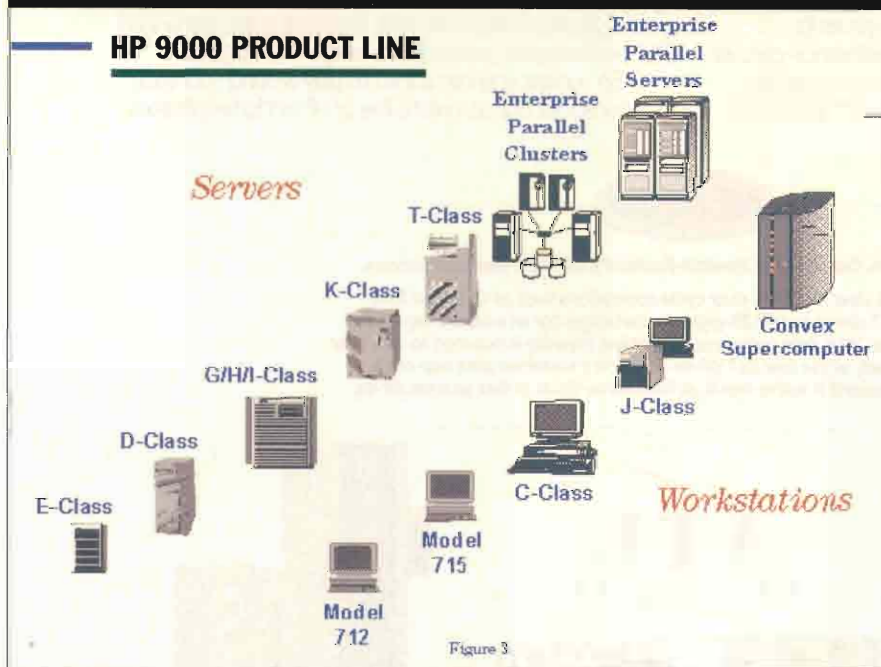

HP 9000 Product Line

21 users need data.
That means
printing 93,109
pages of reports,
assembling and
delivering them by
2 o'clock.



Or not.

VISTA Plus

VISTA Plus is the easy electronic report management solution that:

- ~ Provides common access to MPE and UNIX reports without application changes.
- ~ Users are up and running in no time.
- ~ Full Windows functionality.
- ~ Page content based security.
- ~ Allows timely decision making with fast, efficient data access.
- ~ Saves paper, resources and time.
- ~ Integrates with spreadsheets, word processors and other PC applications.

Phone: 714-728-1434, e-mail: info@quests.com.

All names are registered trademarks or trademarks of their owners.

QUEST SOFTWARE
Expect a solution.



IN AUTOMATED TAPE LIBRARIES, YOU CAN'T AFFORD TO PLAY AROUND.

Especially since your company's business critical data requires serious, fail safe storage solutions. NOW, HP certified and recommended DLT™ automated solutions are available from ATL Products™.

These robust libraries combine industry leading DLT tape technology from Quantum Corp. with ATL's field proven automation technology to bring you the high performance solution you've been waiting for.

That's why HP selected ATL Products as its exclusive DLT automated tape library reference partner for their HP9000 Servers. And to assure you success, we're fully compatible with HP's Omniback™ and other

leading data management software packages.

With capacities and performance perfectly matched for the HP9000 system, there's no need to play around with your future needs either.

For years ATL™ has been defining the industry's technology standards, providing unparalleled field proven reliability and support. And by building our libraries to last for many years, ATL will support your future needs when your application become more demanding and enhanced DLT performance products are ready for integration.

So - unless you can afford to play around - contact us now about our complete line of HP endorsed libraries.



ATL's ACL4/52 Is Certified For Hewlett-Packard's HP9000 Business Servers.

The ACL4/52 is ideal for heavy duty cycle applications such as OLTP and DSS. It features four DLT drives and 52 20-gigabyte cartridges for an available capacity of more than 1 terabyte. With data compression enabled, capacity is boosted to well over 2 terabytes. Each of the four DLT drives supports a sustained data rate of 1.5 megabytes per second in native mode, at least three times as fast as 8mm drives.

ATL
PRODUCTS
AN ODETICS COMPANY



Quantum

1515 S. Manchester Avenue, Anaheim, California 92802 USA
800-677-6268 714-780 7790 <http://www.atlp.com/>

CIRCLE 241 ON READER CARD



THE STORY CONTINUES: HP PA-8000-BASED SYSTEMS

The continuing story of HP PA-RISC-based computers is opening another chapter: systems based on the PA-8000 processor, the first full 64-bit implementation of HP's PA-RISC processors. The PA-8000 offers the following functions and features:

- ◆ Binary compatibility with its predecessors such as the PA-7200.
- ◆ A four-way scheduler, allowing the processor to deliver four-way superscalar performance. Up to four instructions can be issued simultaneously.
- ◆ 10 functional units. The large number of functional units (five individual units, each implemented

twice) ensures constant instruction-level parallelism, rather than just sporadic.

- ◆ The concept of "Intelligent Execution." The most important aspects of this concept are out-of-order execution, branch prediction and speculative execution. All of these have been implemented to enable the processor to deliver a consistent performance level. Out-of-order execution is a method to resolve situations that commonly prevent a processor from executing instructions in parallel. For example, if instruction number 2 needs the result of instruction number 1, these instructions cannot be executed simultaneously. While most processors will just execute

instruction number 1 the PA-8000 uses a 56-entry reorder-buffer to execute instructions other than instruction number 2 in parallel with instruction 1. This procedure effectively allows more instruction-level parallelism.

Today, the PA-8000 is available for products of the C-, J- and K-Class. It is offered at two different clock speeds — 160 MHz and 180 MHz. In addition, there also are new graphics cards: the HP Visualize-48XP for 3D performance, and the HP Visualize-EG for 2D performance.

SPEEDS AND FEEDS

At the top of HP's new offering is the HP Visual K460-XP. Suited for 3D applications, it is based on the PA-8000 at 180 MHz and includes the new HP Visualize-48XP graphics card. It delivers 11.8 SPECint95 and 20.0 SPECfp95 of computer power. This compares to 8.9 SPECint95 and 12.56 SPECfp95 of a Silicon Graphics (SGI) Power Challenge GR, for example. The graphics capabilities of the K460-XP deliver 10 million 3D vectors per second as compared to SGI's 1.3 million, 3.8 million Triangles per second versus SGI's .47 million, or 1.9 million LSQs comparing to SGI's .185 million.

Next, consider the HP Visualize C180-XP with HP Visualize-48XP graphics. Also using the PA-8000 at 180 MHz, it delivers 11.8 SPECint95 and 18.7 SPECfp95. The graphics characteristics reach 365 PLBwire and 424 PLBsurf.

The PA-8000 targets 2D systems as well. The HP Visualize C160-EG, using the PA-8000 at 160 MHz and the HP Visualize-EG Graphics, is priced for 2D systems as well as delivering 10.4 SPECint95 and 16.3 SPECfp95. The Sun Ultra 170E Creator is at the same price level as the HP C160-EG, but doesn't exceed 5.6 SPECint95 and 9.1 SPECfp95. The HP C160-EG offers graphics performance of 29.8 Xmark93 compared to Sun's 16.4 and 4.8 million X11 vectors against Sun's 1.8 million. Finally, systems like the C100/C110 or the J200/J210/J210XC may be upgraded with PA-8000 processors.

— Klaus Armbruster, Technology Program Manager at HP Germany.



*You could shop
around endlessly
to solve all your
networking
and output
management
needs.*



Or not.

Quest Product Family

Our complete family of HP networking and output management solutions means one-stop shopping:

- ~ VISTA Plus, the easy-to-use electronic report management solution.
- ~ NBSpool, the high-performance spool management solution.
- ~ NFS/iX (Client and Server), the only NFS for MPE XL and POSIX.
- ~ NetBase, the comprehensive clustering and disaster recovery solution.
- ~ NetBase Client, straightforward access to MPE data from UNIX and LANs.
- ~ EnterPrint™, a robust and scaleable server for Xerox production printers on TCP/IP networks.
- ~ QUARK Plus, the multi-platform compression solution.



Phone: 714-720-1434, e-mail: info@quests.com.

All names are registered trademarks or trademarks of their owners.

**QUEST
SOFTWARE**
Expect a solution.

All Worked Up

(continued from page 23)

capacity and performance.

If you have been off working on other projects for the last year, you may be surprised at some of the storage items listed. Both the HA storage systems and Symmetrix 3000 are relatively new solutions. Let's take a closer look at these.

The HP High Availability Storage System provides a large amount of redundancy, including the following:

- Redundant power supplies — If you buy an optional second power supply, then the load is shared among the two power supplies. If one power supply fails, the other handles the entire load. You can replace the power supplies from the front of the cabinet with no tools.
- Redundant cooling fans — Two cooling fans come standard with the unit. If a fan fails, you can replace it while the system is running.
- Dual SCSI Interfaces — You can mix Fast Wide Differential disks with

Single Ended DDS-2 devices, or use the two buses to support mirroring.

- Storage Modules — Storage Modules are hot pluggable like the power supplies and cooling fans. The 2 GB low-profile disk modules and 4 GB half-height modules are supported. DDS-2 and CD-ROM drives also can be used.

Symmetrix 3000 targets a data center environment that needs hundreds of gigabytes of disk space. The Symmetrix unit supports RAID and other levels of redundancy. The most interesting aspect of this unit, however, is the ability to connect it to multiple hosts.

IN THE WORKS

THERE ARE TOO many new products and topics to cover in a single article. But look for continued coverage of HP's UNIX hardware and HP-UX throughout the year, including Fred

Mallet's UNIX At Large and Jill Huntington-Lee's Inner Networking columns.

—Marty Poniatowski is a Technical Consultant with Hewlett-Packard in the New York area working on server and workstation installations. He has written over 50 technical articles in computer industry trade publications. He also has written three books published by Prentice Hall: Learning the HP-UX Operating System (1996); HP-UX 10.x System Administration (1995); and The HP-UX System Administrator's "How To" Book (1993). All can be ordered from Cardinal Business Media via CBM Books, care of Whitehurst and Clark, 100 Newfield Ave., Edison, NJ 08837; or call (800)-285-1755 or (908) 225-2727.

Would you like to continue to see articles on this topic?
Circle on reader card
yes 350 no 349

BIG on Power.

ERICOM SOFTWARE'S

PowerTerm

INTER-CONNECT SERIES

The most powerful PC terminal emulator
At the lowest price.

- Lots of terminal types for UNIX, VMS, AS/400 & IBM Mainframes.
- VT420, WYSE 60, DG, SCO, 3270, 5250 and more.
- File transfer, scripting, API and more.
- 32-bit NT & 95 versions – DOS too!
- Includes Newt TCP/IP stack.
- FREE copy on the Web at:
http://www.unipress.com/free_evals

800-222-0550 • 908-287-2100
2025 Lincoln Highway • Edison, NJ 08817
<http://www.unipress.com> • info@unipress.com

All trademarks acknowledged.

CIRCLE 138 ON READER CARD

OUR 15th YEAR

QUALITY HP WORKSTATIONS - WITHOUT THE HP PRICE

RENT • LEASE • BUY

Immediate Delivery On Most Items

QUALITY MAINTENANCE FOR HP WORKSTATIONS

Ask About Our RAPID REPLACEMENT Low Cost Maintenance Programs Which Include On-Site Spares

- 700 SERIES: All Models
- X-STATIONS: ENVIZEX, C270X
- All 300, 400T and 400E Series
- Memory, Features & Disc Upgrades for all Workstations
- CPU Upgrades: All Models

More Than 1500 Satisfied Customers
Throughout The USA and Worldwide

For technical info, specs or pricing
call Mordy or Carol



C.S.U. Industries, Inc.
395 Pearsall Avenue, Cedarhurst, NY 11516
(516) 239-4310 FAX (516) 239-8374

CIRCLE 213 ON READER CARD

Macs. PCs. UNIX.
You don't need an operating system.
You need a referee.

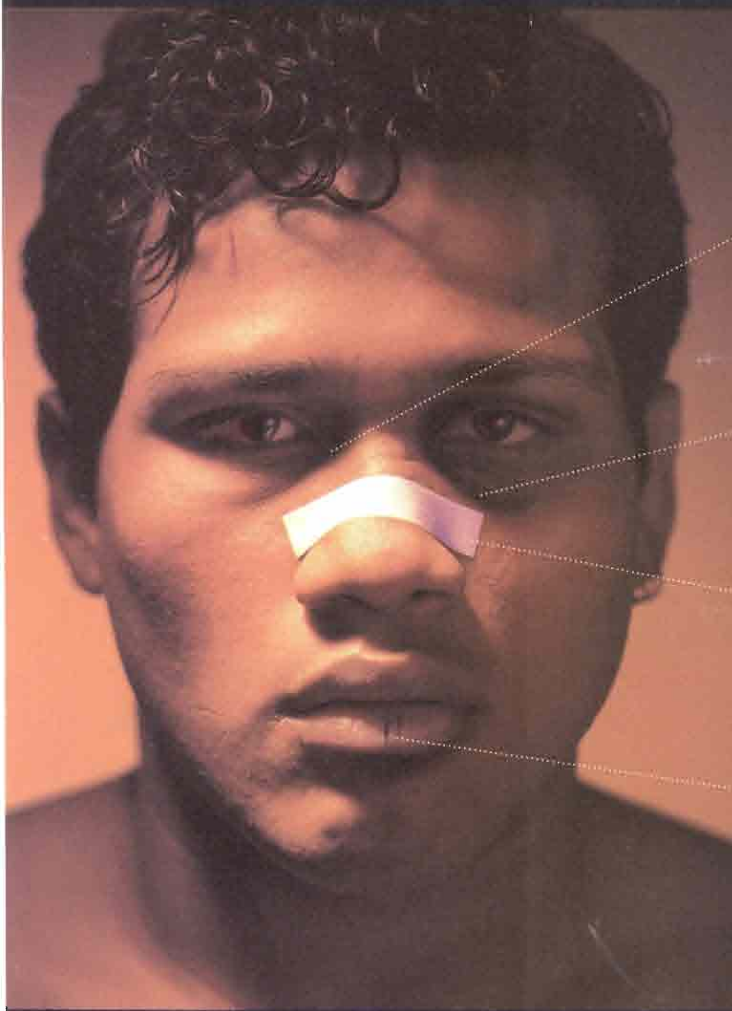

ROUND 1: Enraged by the growing number of apps they can't run, the office Mac™ pack accuses you of being sweet on Microsoft. Yow!

ROUND 2: A couple of heavies from the UNIX® gang corner you in the mail room, demanding PCs so they can run Windows-based email. Ooph!

ROUND 3: There's money in the budget for a new operating system, but proposals for new hardware get thrown back in your face. Ouch!

ROUND 4: Too beat up to answer the bell, you throw in the towel. Too bad. With the right software, you coulda been a contender.

How'd you like to meet the software equivalent of the guy in the striped shirt? We're Insignia Solutions, and we keep the peace between you and your different operating systems. Our SoftWindows™ lets you run Windows® on Macs, as well as on UNIX. And with NTRIGUE™, you can run Windows on any hardware. (So pull all those 386s, Mac Classics and X terminals out of the dumpster.) Give us a **INSIGNIA SOLUTIONS** call today at 1-800-848-7677 to learn more. We'll be happy to help you up off the mat.

Insignia Solutions is a registered trademark and NTRIGUE is a trademark of Insignia Solutions Inc. SoftWindows is a trademark used under license. Microsoft and Windows are registered trademarks of Microsoft Corporation. Mac is a trademark of Apple Computer, Inc. UNIX is a registered trademark licensed exclusively through X/Open company, Ltd. ©1996 Insignia Solutions Inc.

CIRCLE 218 ON READER CARD

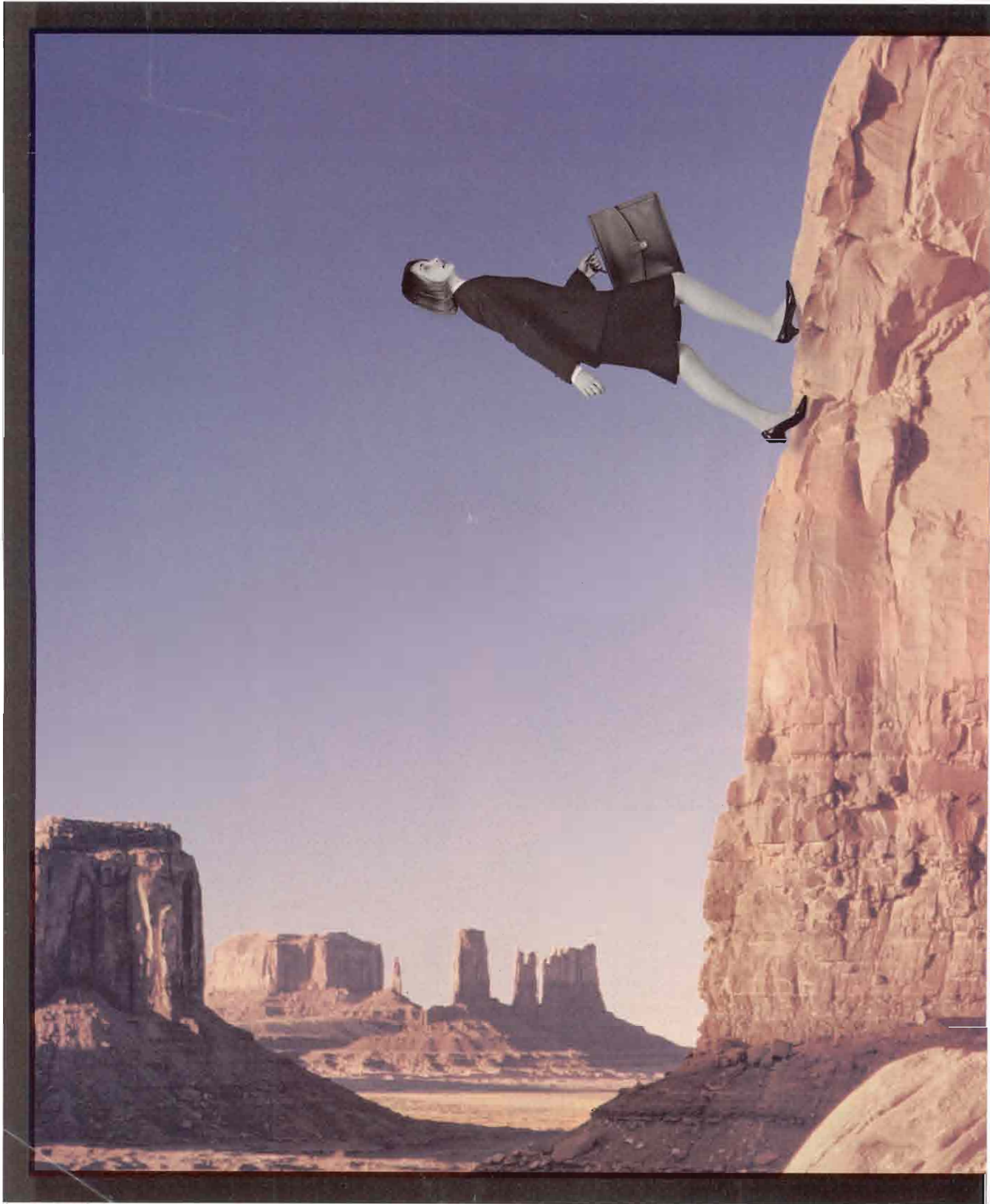

You want open systems computing.
You don't want to move mountains of
critical data to a new platform.

What computer system do you have?

If you're running an IMAGE/SQL or ALLBASE/SQL
database on our HP 3000, you can gain the flexibility and
improved data access of client/server computing
without the steep learning curve, high development costs,
and risk of moving your data to a new platform.

If the business decisions are yours,
the computer system should be ours.

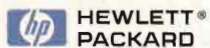

Computer Systems

In The HP Enter

George A. Thompson

By most accounts, Microsoft Windows NT (with a little performance boost from Intel's Pentium CPUs) is now coming on strong in the enterprise as a server platform. But billions of R&D dollars later, most UNIX vendors, HP in particular, are hardly ready to cower in NT's shadow. But they do need to be prepared. That means a reasonably coherent UNIX-NT integration strategy must be ready for presentation to IS/IT managers who have been noodling with NT for the past two years and are now poised to take NT into prime time enterprise production.

Until recently, HP has played the NT card close to its UNIX vest. But this year, after a reorganization in late 1995 that finally blended HP's separate UNIX and PC divisions under Rick Belluzzo, HP has at least demonstrated a willingness to accept and integrate NT within its UNIX accounts. HP, in fact, wants to be your "trusted advisor" on the issue of UNIX/NT integration. But just how well do UNIX and NT fit together in HP's corporate mind? In an exclusive interview with *HP Professional* Senior Editor George A. Thompson, Jonathan Goulden, director of HP's multivendor service and support program, in HP's Worldwide Computer Support Organization's (WCSO) Software Services and Technology Group, talks frankly about the UNIX/NT relationship as he sees it within the enterprise.

Goulden ought to know. He has been monitoring support needs associated with the Intel platform at the corporate level for three years. Because his mission is to determine what services are going to be offered to assist HP customers, he hears about it when things break. He's also there to otherwise help, advise and consult with HP customers when the gulf between UNIX and NT seems too difficult to bridge. For instance, he claims that by the end of 1996, HP will have 500 support engineers with Windows NT and network OS training.

HP Professional: From your perspective, has the reorganization [this past October] changed anything?

Goulden: Not at all. I was already supporting both of those [PC and UNIX] divisions. It didn't make much difference.

HP Professional: What does it mean generally?

Goulden: Making sure that HP takes advantage of its core competencies with both its Intel-based Vectras or NetServers, as well as with our HP 9000 [UNIX-based] systems.

HP Professional: How does that differ from Digital's or IBM's strategy?

Goulden: Neither has much of a presence in UNIX. People are not going to Digital for Digital UNIX. Nor are they going to IBM to get a UNIX replacement for their mainframe. The only other real player out there for UNIX is Sun.

HP Professional: But Sun doesn't have the Windows NT component.

Goulden: Exactly.

HP Professional: What about Digital's Alpha/NT combination?

Goulden: Digital makes good boxes, but we are on the Intel platform with our NetServers and Windows NT. We're jointly developing the next version of those Intel processors with Intel. We think that leaves us with an incredible marketing position.

HP Professional: Have you heard much about the day when Windows NT lands on PA-RISC?

Goulden: Not anymore. I used to hear that. But I haven't heard it recently.

prise

HP Professional: How would you characterize the growth rates of Windows NT in HP accounts?

Goulden: Most of the growth rate is being driven at the departmental server level, especially as a replacement for [Novell's] NetWare. Virtually all of our top accounts are looking at it in one way or another.

HP Professional: So, the growth of NT is coming at NetWare's expense?

Goulden: Yes. From Microsoft's perspective, that's where most of the growth has come from.

HP Professional: What about HP's perspective?

Goulden: From HP's perspective, things are looking pretty rosy. Although the market as a whole has not grown as quickly, we have continued to grow our UNIX business.

HP Professional: What does that say about the future of NetWare?

Goulden: They have a massive installed base. And technically, with respect to their NetWare Directory Services (NDS), NetWare has some advantages. But that's something they don't push to the end-user marketplace, it's a matter of convincing developers to take advantage of it and exploit it. But people are not necessarily buying NT to replace NetWare. They are buying applications that work on NT (which handles many of the network functions that NetWare already handles) and then they ask, "Why do I need NetWare?"

HP Professional: What kinds of questions are your customers grappling with?

Goulden: From a software perspective,

the questions are: How do I compare Windows NT and UNIX? And when is it appropriate to use one or the other? At the hardware level, they are thinking about some kind of Intel platform — whether it's from HP, Compaq or IBM. Digital's Alpha [for example] is not at the top the list.

HP Professional: What are the top three NT versus UNIX concerns that you hear the most?

Goulden: 1. Are the applications there? Do they meet my needs? Although most of the big application vendors are porting to NT, those ports are still in progress or are early in the life cycle.

2. How high can NT go? When we talk about high availability, Intel servers and Windows NT cannot go anywhere near as high as UNIX — yet. You can't, for example, put a terrabyte of data on an Intel server.

3. And how is this NT thing going to do [on Intel-based servers]? What does great performance really mean? Not just in terms of raw CPU power, but total throughput.

HP Professional: How are they making that performance determination?

Goulden: They are usually piloting. First in IT labs. Now there are pilots with 200 to 300 clients involved and they are working their way through that.

HP Professional: I'm surprised you didn't mention systems and network management as an issue.

Goulden: It's there. But for now, there's not enough widespread deployment for it to be in the top three. But it will be there when we get to a major roll out.

HP Professional: How is UNIX and NT integration evolving?

Goulden: There are two key areas where we are seeing UNIX and NT systems working together: The most advanced is a three-tier implementation in — say something like an SAP R/3 environment, with a database server, an application server and a presentation server. The database server is definitively running on HP-UX. The application server *might be a UNIX [box] or it might be NT*. We are seeing, however, [in

advanced implementations] that NT is the preferred solution. And the presentation piece is a PC of some kind, most likely running Windows 95. Or the presentation can be laptop — as mobile computing seems to be kicking in.

The second area — where the next application going in happens to be running on NT Server — is not as tightly integrated. It's a parallel implementation. The NT server is already accessing corporate databases or warehouses that happen to be running on UNIX. Because it doesn't require many [drastic] changes, we are actually seeing more of the parallel implementations.

HP Professional: Would you say that we're still in an early adoption phase?

Goulden: Absolutely. The high-end roll out is yet to come.

HP Professional: When do you expect to see the next phase?

Goulden: For large corporations, I would expect that to occur over the next year as the initial pilots close out. By 1997, we will move out of the early adoption phase.

HP Professional: Do you see HP going from a consulting role to an integrator role?

Goulden: You got it. Then it rolls into maintenance mode.

HP Professional: What about small- and medium-sized businesses?

Goulden: We provide support services to them. It's a relatively untapped market from an NT perspective. As for HP, we just completed a small business small office alliance with Microsoft. We think there's a huge growth potential. In general, you don't get into consulting engagements with them. They look toward their application provider.

HP Professional: What are your future goals?

Goulden: To make sure I stay attached to whatever growth rate does occur with NT in the corporate marketplace. I don't want to be left behind. And, to exploit the channel growth in the small- and medium-sized marketplace.

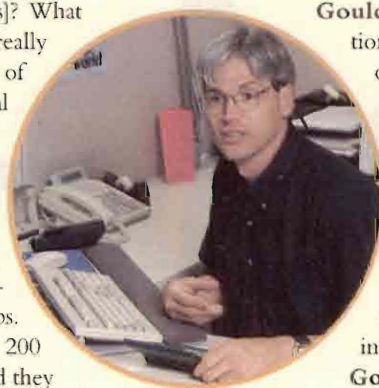

Jonathan Goulden
Director of HP's multivendor
service and support program in
HP's WSCO.

64-bits.

No houts.

AS/400 Advanced Series While several computer systems offer 64-bit technology, AS/400[®] gives you something that none of the others can match: over 25,000 applications that can actually run on it.

Right now.

The difference is in the architecture. Powered by PowerPC™ RISC technology, AS/400 is every bit 64-bit – from hardware to operating system to software. Applications are already optimized for 64-bit speed and performance without the need for lengthy rewrites or time-consuming recompiles. (A claim that no other company can make.)

In fact, over eight years and five major upgrades,

AS/400 has never once obsoleted a piece of software. And we're not about to start now. Which means the software you ran yesterday will still run tomorrow. Only faster.

It also makes AS/400 the perfect platform for today's power-hungry applications like data warehousing, multimedia and the Internet. And an even better way to protect your hardware and software investment.

Now, and down the road.

To put your business on the fast track to 64-bit computing, drop by www.as400.ibm.com or call us at 1 800 IBM-4YOU, Priority Code GAS647 and ask about our 3.9% financing*.



Solutions for a small planet™

CIRCLE 149 ON READER CARD

*Total Solution Financing available from IBM Credit Corporation to qualified commercial, state and local government customers for AS/400 Advanced Series together with selected software and services. 3.9% applies to best credit customers on 24- to 36-month terms. Other rates and terms available. Rates vary based on credit rating, financing terms and options, and are subject to change without notice. Offer subject to credit approval and other restrictions may apply. Systems must be installed on or before December 31, 1996. IBM and AS/400 are registered trademarks and PowerPC and Solutions for a small planet are trademarks of International Business Machines Corporation. All other company and/or product names are trademarks or registered trademarks of their respective companies. © 1996 IBM Corporation.



We Come Not To Bury NT

In May, HP announced a program it's calling "IT Collaboration," a broad strategic plan targeted at

supporting the coexistence of mixed platforms including UNIX, NetWare, Windows NT and other various Microsoft flavors of Windows. In other words, HP is officially acknowledging that Windows NT is here to stay. But there's also a clear subliminal message: UNIX is not going away, either. And because Windows NT and UNIX will be around for a while, HP will be happy to sell you the tools for dealing with both.

But back to the announcement. IT Collaboration is "solutions-focused," which is probably supposed to mean that these are not just assorted point products, but interoperable, well-integrated modules that just, by the way, happen to have been developed by different HP divisions. As such, "solutions-focused" also probably means that sorting out the relevant product-order codes and explaining your total order to the sales rep will be a collaborative experience in and of itself. On the positive side, IT Collaboration products are available at "workgroup-friendly prices," meaning profit margins will be lower, so the channels will be greased to sell in volume. Finally, all IT Collaboration products will feature greater flexibility and manageability.

I happen to like that last word a lot, because most system software announcements tend to ignore manageability, or at best, mention it as an afterthought. HP deserves bonus points for

mentioning the word. But remember this: manageability requires lots of planning and lots of configuration effort. But, it appears that HP has a plan. And it's called IT/Administration for Workgroups — an adaptation of the IT/Administration (formerly HP/AdminCenter) product I've discussed in this column in the past. According to the announcement, IT/Administration will support fill-in-the-blank screens making it "an ideal solution for part-time system administrators." According to HP, the task of distributing system software updates will be reduced from "hours to minutes."

REDUCTIO AD ABSURDUM

Hours to minutes? Most system software updates take days, not hours. Rolling out new applications, whether pre-packaged or developed in-house, takes even longer. Yes, most software updates can be accomplished in less time when automated software distribution systems are implemented. But as any well-seasoned systems administrator knows, deploying a software distribution system requires *months of planning* — even when the environment is homogeneous. Setting up an automated software distrib-

ution system is hardly a task for a part-time systems administrator.

The existing "Enterprise-Level" IT/Administration offering — upon which the "Workgroups" product is based — is a complex product requiring an understanding of object-oriented concepts and more than a passing familiarity with a UNIX-oriented approach to systems administration. These are not the talents commonly possessed by the usual part-time systems administrator. There's only a slim chance that the average part-time administrator will have the skills and the time to effectively deploy an object-oriented UNIX-like tool. But, HP has promised pre-defined queries and tables to simplify the job of rolling out IT/Administration for Workgroups. That will help. But I'm doubtful whether the templates will be all it takes to turn a complex, esoteric product into a turnkey solution. And turnkey is the operative word, or resellers won't be able to push it through the channel.

(continued on page 37)



Will drag-and-drop icons and common fill-in-the-blank forms make IT/Administration for Workgroups easy to use?

Why does Adager check your databases every time?

Why do *you* check your tires, your oil, and all the other vital signs of your car *before* you start racing?

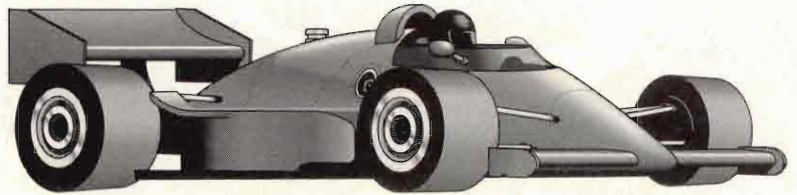

Because your life depends on your carefulness.

By design, Adager does a lot of work under the hood for you. Every time it accesses an IMAGE database (whether IMAGE/3000, TurboIMAGE, or IMAGE/SQL), Adager does a thorough analysis of the internal—privileged—structures that support your organization's vital information.

IMAGE is an unusually robust DBMS that stands out in this era of sloppy computing practices. As a result, your HP3000 IMAGE databases may seem to function perfectly well even though they may have subtle internal inconsistencies (usually caused by operator errors or rare hardware problems).

Even though it is *possible*, it is *unwise* to continue operating with *any* inconsistencies. You would not want to race with an under-inflated tire, would you?

This is why Adager is so strict. At every opportunity, it automatically looks for the tiniest variation from the IMAGE rules of the road (according to your particular version of IMAGE, whether IMAGE/3000, TurboIMAGE, or IMAGE/SQL).

Old Adager users are amazed at how Adager detects and fixes their database problems before anyone else has even issued a warning.

New Adager users are intrigued by the discovery that some of their databases were not as healthy as they thought they were (before Adager came along to catch and correct them).

A system manager who recently received a demonstration Adager kit asked us (thus motivating this ad): *Why is Adager complaining about this particular database? Nobody else does.*

Our answer: Adager is always on the leading edge and has incorporated, before anyone else, full support for the latest IMAGE enhancements (and their corresponding rules), such as Jumbo datasets (datasets larger than 4 gigabytes), automatic replication of your database changes under NetBase and SharePlex, dynamic dataset expansion, SQL DBEnvironments, and so on.

Adager knows—and enforces—the rules, so you can enjoy a safe race.



The Adapter/Manager for IMAGE/SQL databases

Adager Corporation • Sun Valley, Idaho 83353-3000 • U.S.A. • (208) 726-9100
Fax (208) 726-8191 • support@adager.com • http://www.adager.com
Toll-free from North America: Telephone (800) 533-7346 • Fax (800) 247-7346



Channel
Partner

Interex Presents

HP WORLD '96

See hundreds
of exhibitors!

The Conference & Expo
for Hewlett-Packard
Computing Solutions

Keeping You
A Step Ahead

Conference

- Hands-on solutions
- Peer-to-peer interaction
- Expert optimization techniques
- Real-world migration tips

Expo

- Create high availability solutions
- Improve high-end performance and scalability
- Develop migration strategies
- Learn about new technologies
- Make the right purchasing decisions

Sponsored and managed by the
Association of Hewlett-Packard
Computing Professionals (Interex).

CIRCLE 150 ON READER CARD

Get HP WORLD '96 registration
and "Free Expo Pass" information!

See us on the WWW at <http://www.interex.org/>

Call an HP WORLD '96 Conference Representative at 1.800.990.EXPO
or e-mail us at conference@interex.org.

INNER NETWORKING (continued from page 34)

IT/Administration for Workgroups supports more than just software distribution. But the additional tasks — file, printer, user management for Windows NT systems — must be accomplished from HP's new Advanced Server/9000 platform (an application that's an implementation of AT&T's Advanced Server running on top of HP-UX), not from a native Windows NT system, at least not until the product's next release, sched-

**IT/Administration
for Workgroups is really
a UNIX-centric solution,
although you can use it
to manage your
Windows NT systems.**

uled for mid-1997. Until then, IT/Administration for Workgroups is really a UNIX-centric solution. Although you can use it to manage Windows NT systems, you've got to understand UNIX to configure and operate the management tool.

FULL OF GOOD INTENTIONS

Yet in all fairness, IT Collaboration represents much more than just management. The other five technology areas of IT Collaboration are NOS/Directory Services, Messaging/Groupware, Security Services, Distributed Application Access and Enterprise Networking. Pulling all this together into one product family is impressive, and promising. And as far as the management component goes, the price is right.

The idea is good one, but it's the execution that will make or break this product. If it's truly easy to use, it will sell in volume. If it's not, users will look for easier management solutions — most likely Windows NT-based ones — to manage their workgroup environments.

Does it get any better than this? If so, tell Jill at huntingja@mcgraw-hill.com.

Would you like to continue to see articles on this topic?
Circle on reader card
yes 306 no 305

SITES

IN OUR

Do you need access to your work systems from home? Or maybe you just want a personal e-mail account? You don't have to be afraid of the big bad Web. Just read *HP Professional's* exclusive online column for tips on establishing your own Web away from work at www.cardinal.com/hppro. Also look online for additional new hardware and software products from HP and third-party vendors.

**Reliable,
loyal,
and he'll
always
be there
for you
long after
you take
him home**

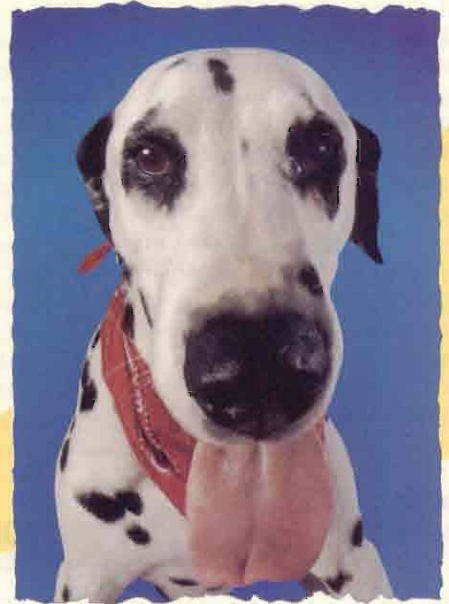

Much like Workstation Solutions

After the sale is made and the product installed is when you start to measure the true performance of your backup solution. Which is why choosing the right company is just as critical as choosing the right product. At Workstation Solutions, we pride ourselves on having one of the best customer support organizations in the industry. When you call us for assistance, you'll receive prompt and personalized service by one of our experienced support professionals. We not only provide you with our highly reliable Quick Restore V2 backup software, but a company you can rely on to keep your valuable data intact, and your system up and running. Call us today at **800.487.0080** and we'll send you a FREE CD-ROM product demo.

QUICK RESTORE V2

FEATURES

- Control backup & recovery on a heterogeneous network without using NFS
- On-line indexing, automatic volume location & direct-to-block positioning
- Full support for popular robots and bar code readers
- Easy-to-use and highly reliable or your money back!



workstation solutions, inc. • one overlook drive • amherst nh 03031 • 603.880.0080 fax 603.880.0696
e-mail info@worksta.com • <http://www.worksta.com>

All company and product names are trademarks or registered trademarks of their respective owners.

CIRCLE 253 ON READER CARD

new Products

DataExpress ODBCLink Available In 32-Bit

M.B. Foster released Version 5.40 of DataExpress' ODBCLink option that now provides a 32-bit version for use with Windows 95 and Windows NT. The ODBCLink option of DataExpress allows HP 3000 customers to reach TurboIMAGE data directly or via Cognos PDL dictionaries to TurboIMAGE, KSAM and MPE (flat) files. Relational databases supported include ALLBASE/SQL, IMAGE/SQL and Oracle. The initial release of the 32-bit version connects using WinSock only. Contact M.B. Foster Associates, 82 Main St. S., Chesterville, ON K0C 1H0; (800) 267-9377.

Circle 400 on reader card

RoboMon UNIX Supports HP-UX

Heroix Corp. announced that RoboMon supports HP-UX 10. RoboMon users can modify problem sensors on a remote node from their local machine or can supplement RoboMon's supplied problem sensors with their own, and manage them via the same GUI. Finally, additional browsable documentation is available online.

In addition, RoboMon UNIX operates seamlessly with and can be managed by NetView and OpenView, to provide rules-based event management on an enterprise-wide basis.

RoboMon runs on HP-UX, AIX, Digital UNIX, Solaris, SunOS, Windows NT and OpenVMS. Prices range from \$300 to \$2,500.

Contact Heroix Corp., 120 Wells Ave., Newton, MA 02159; (800) 229-6500; info@heroix.com; www.heroix.com.

Circle 399 on reader card

Information Advantage Announces WebOLAP

Information Advantage Inc. announced WebOLAP, an enhancement to the company's DecisionSuite Server, that gives users the ability to perform OLAP of structured

database content, such as financial, sales and customer information, over the Web.

WebOLAP provides an intermediate computation layer for analysis of structured content, combining dynamic OLAP analysis with intelligent agents and multi-level security. Data is sent through the Web-standard CGI. Users can conduct their own ad-hoc analysis of the most current data available instead of being limited to static, out-of-date reports.

The new version of DecisionSuite Server with Web support starts at \$29,995. Contact Information Advantage, 7401 Metro Blvd., Ste. 5000, Edina, MN 55439; (800) 959-7015; karen.drost@infoadvan.com; www.infoadvan.com.

Circle 398 on reader card

ORBiT, SolutionSoft Release CSM

ORBiT Software and SolutionSoft Systems released Compression Storage Manager (CSM), an online archiving solution for the HP 3000.

CSM reduces costs and increases system uptime by more efficiently using available system disk space. It does this by keeping certain inactive and seldom-used files in a compressed state and automatically decompressing them when a user or program accesses them.

Contact ORBiT Software, 315 Diablo Rd., Ste. 210, Danville, CA 94526; (510) 837-4143; sales@orbitsw.com.

Circle 397 on reader card

Empress Software Introduces DataWEB

Empress Software Inc. released Empress DataWEB, an application development environment designed for HYPERMEDIA Web Data Management (HWDM). It allows users to build Web-based applications using the secure data storage and management capabilities of the Empress RDBMS. At the core of the product is Empress HYPERMEDIA, the Empress Web HTML

toolkit. Empress DataWEB will be available on CD-ROM for HP-UX, IBM AIX, SGI Irix, Sun Solaris, SCO Open Server 5, Solaris x86 and Linux. Contact Empress Software Inc., 6401 Golden Triangle Dr., Ste. 220, Greenbelt, MD 20770; (301) 220-1919; www.empress.com.

Circle 396 on reader card

Qualix Systems Group Launches QualixHA

Qualix Systems Group announced the QualixHA Solutions product line, a suite that provides comprehensive and integrated monitoring, restart, failover and recovery capabilities. Components include: VERITAS FirstWatch, the base HA failover engine; Qualix HA-Environment, a software that simplifies the installation of the base HA monitoring engine and expands the HA support volume managers, file systems and RAID products from multiple vendors; and QualixHA-Modules, optional software components which provide high availability support for specific applications or software subsystems.

The QualixHA Solutions are available on HP-UX, SunOS, Solaris and RS/6000 AIX platforms. Prices for the complete HA solutions range from \$8,000 to \$95,000 depending on configuration and options. Contact Qualix Group Inc., 1900 S. Norfolk St., #224, San Mateo, CA 94403; (415) 572-0200; info@qualix.com; www.qualix.com.

Circle 395 on reader card

UniPress Produces PowerTerm

UniPress Software Inc. announced PowerTerm, a terminal emulator for Microsoft Windows, Windows 95 and Windows NT PCs developed by Ericom Software Ltd. PowerTerm links those PC desktops to resources such as UNIX running on HP, IBM, Digital, Sun and DG, OpenVMS, and IBM AS/400 and mainframes in order to run current and legacy applications. The 3270 and 5250 versions include PowerGUI.

PowerTerm emulates the following: VT420, 320, 220, 100 and 52, SCO-ANSI, Wyse 50/60, AT386, AIXterm, DG/MV, D-412, IBM 3270 and IBM 5250, and communicates via TCP/IP, WinSock, direct via COM port, modem, Pathworks DECnet (Cterm), Pathworks LAT, INT 14, BAPI, and TN3270 and TN5250 over TCP/IP. For PowerTerm 3270, Novell Gateway/NetWare for SAA

(continued on page 42)

New

for the HP Market

Bus-Tech[®]
announces **Datablaster II,**
the fastest and least
expensive way to
move data. Period!

The screenshot shows a window titled "BUS-TECH". On the left, there are two menu boxes: "Mainframe Options" with items IBM, AMDAHL, AS/400, HITACHI, UNISYS, and UNIX; and "Transport Options" with items ESCON CHANNELS, PARALLEL CHANNELS, and SCSI II. A red arrow labeled "DATABLASTER II" points from the transport options to a box on the right that says "Designed Specifically for Bulk Transfers". Below the menus is a list of features: High speed mainframe to server file transfer, High speed server to server file transfer, No protocol overhead (SNA and TCP/IP), No host or server modifications, ESCON option available, and Growing library of third party data-migration tools. At the bottom of the window, it says "Now supports SCSI to SCSI". To the right of the window, there is a box labeled "To any server" with items DDS, HEWLETT PACKARD, UNIX, WINDOWS NT, and OTHERS.

CALL 800-284-3172

<http://www.bustech.com>

BUS-TECH

INC.

"Connecting Today to Tomorrow"

129 Middlesex Turnpike, Burlington, MA 01803

Product and company names mentioned in this publication may be trademarks or registered trademarks of their respective companies and are hereby acknowledged.

CIRCLE 196 ON READER CARD

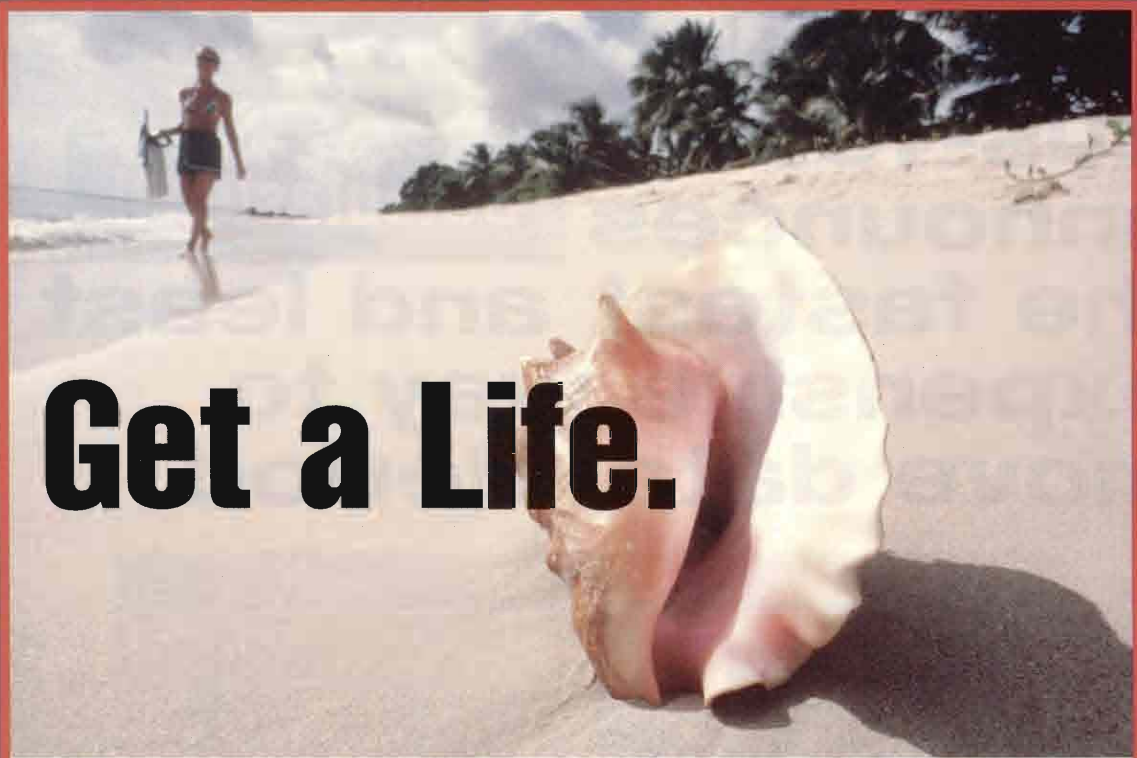

Get a Life.

Do You Ever Feel Your Life Doesn't Exist Outside of Work?

Does poor response time turn your weekends into workdays? Would a Saturday or Sunday without reloading your disk drives be a miracle? Too bad. Life doesn't have to be that way.

Getting control over your operating environment is no easy task. But with the help of **Disk Space Manager**, the job gets a whole lot easier. With this powerful tool at your fingertips, you'll soon be spending more time juggling your social calendar and less time juggling your disk space.

Disk Space Manager is a multi-purpose tool that allows you to manage

your disk environment easily and efficiently, gaining substantial new space without the expense of additional hardware. It runs online, without operator intervention, and uses HP's Transaction Manager (XM) to protect data integrity.

Using features like truncation, defragmentation, spreading and combining of files, populate set and manage set, you'll soon be managing your disk environment effortlessly—and you'll be assured of top I/O performance. It's that simple... No juggling. No worries. No weekend interruptions.

**Get Your Life Back.
Get Disk Space Manager.**

**For Free Demo,
Call 1/800/294-1190**



Disk Space Manager is a copyright of SolutionSoft Systems. All rights reserved, 1996.

DISKSPACE MANAGER

A Bradmark Solution

CIRCLE 108 ON READER CARD

READER INFORMATION

ADVERTISER INDEX

| Reader Service Number | | Page |
|-----------------------|--|-------|
| 104 | Adager | 35 |
| 241 | ATL Products | 24 |
| 171 | Black River Computers | 10 |
| 108 | Bradmark Technologies Inc. | 40 |
| 196 | Bus-Tech Inc. | 39 |
| 232 | Concorde Technologies | C2 |
| 213 | CSU Industries | 26 |
| 466 | Data Assurance Corp. | 4 |
| 190 | FutureSoft Engineering Inc. | C3 |
| 166 | G.E. Capital | 42 |
| | Hewlett Packard - CA | 28-29 |
| 156 | Hummingbird Communications Ltd. | 13 |
| 149 | IBM Corp. | 32-33 |
| 122 | IEM Inc. | 2 |
| 218 | Insignia Solutions Inc. | 27 |
| 150 | Interex | 36 |
| 107 | ITAC Systems Inc. | 44 |
| 281 | Kingston Technology Corp. | 1 |
| 155 | M.B. Foster Associates | 5 |
| 246 | Newport Digital Corp. | 6 |
| 258 | O'PIN Systems | 43 |
| | PNY Electronics Inc. | 15 |
| 298 | Professional Protocol Corp. | 42 |
| 269 | Quest Software | 19 |
| 483 | Quest Software | 21 |
| 462 | Quest Software | 23 |
| 268 | Quest Software | 25 |
| 261 | Simple Technology | 9 |
| 266 | Technical & Scientific Application (TSA) | 45 |
| 127 | Texas ISA | 18 |
| 138 | Unipress Software | 26 |
| 499 | Unison Software | 22 |
| 201 | Wesson, Taylor, Wells & Assoc. | 11 |
| 253 | Workstation Solutions | 37 |
| | WRQ | C4 |
| 183 | Xerox Corp. | 17 |
| 227 | Xpoint Corp. | 44 |

CONCORDE TECHNOLOGIES CIRCLE 232

Concorde Technologies, Inc., "The Hewlett-Packard Experts" is an HP Channel Partner and Value Added Reseller of HP and third-party products for the HP 9000. Concorde's line of products includes HP 9000 systems, application software, CD-ROM solutions, RAM memory, mass storage peripherals and accessories. For the best prices, availability, warranty and support, **Concorde Technologies.**
Call (800) 359-0282.

IEM CO. CIRCLE 122

IEM offers affordable solutions for the HP environment, including 4mm and 8mm tape drives, autoteaders and carousels, QIC tape drives, optical drives, fixed winchester drives, floppy disk drives and combination drives. IEM's new Building Block product line is a modular storage solution into which you can slide a number of different disk, tape and optical units. IEM offers an automated backup and archival software solution. Most IEM products are available with an HP-IB or SCSI interface for HP 1000, 3000 and 9000 computers.
Call (970) 221-3005 or (800) 321-4671,
or send E-mail to info@iem.com.

KINGSTON TECHNOLOGY CORP. CIRCLE 281

Kingston Technology designs and manufactures memory upgrades for PCs, laptops, workstations and laser printers. The Kingston product line also features mass storage subsystems and processor upgrades.
Call (800) 835-2545,
FAX (714) 435-2699.

M.B. FOSTER ASSOCIATES LTD. CIRCLE 155

DataExpress, the #1 End-User Computing Environment and report writer. EDI Windows, translation software. Reflection and the Network Series.
Call (800) ANSWERS,
FAX (613) 448-2588.

NEWPORT DIGITAL CORP. CIRCLE 246

Accelerator cards for HP 9000 Series 200 plus HP 310 and HP 320. Ten-fold performance improvement.
Call (714) 730-3644.

QUEST SOFTWARE CIRCLE 268, 269, 462 or 483

The only complete HP 3000 solution for:
1) High speed network file and database access.
2) IMAGE, KSAM and MPE file shadowing.
3) Low overhead and network spooling.
Call (714) 720-1434.

SOFTWARE LICENSING CORP. CIRCLE 123

Located at 930 Tahoe Blvd., Unit 802, Incline Village, NV 89454-9436.
Call (800) 831-0882 or (702) 832-0861.
<http://www.slcorp.com>

TEXAS ISA INC. CIRCLE 127

HP-IB and SCSI Tape and Disk Storage • Data Buffers • Power Management Solutions for UNIX and non-UNIX Platforms. Manufacturers of storage solutions for HP environment for 15 years. With our unique new line of Intelligent Automatic Startup and Shutdown devices, companies can now control the AC power ON/OFF schedules of local and remote UNIX systems. The ISA 7030, for instance, can warn of abnormal environmental conditions (temperature, vibration, humidity and smoke), and perform graceful shutdowns and startups. These new devices can significantly enhance system and data security, save time, energy and equipment costs. They also tremendously increase the convenience of managing local and remote systems.

For more information visit us on the World Wide Web:
<http://www.texasisa.com>,
E-mail: info@texasisa.com, or
call (713) 493-5746/ (800) 361-2258.

UNISON SOFTWARE INC. CIRCLE 499

Unison-Tynlabs is a supplier of networked systems management solutions for both UNIX and MPE. Product areas include workload management, storage management, print automation and desktop integration.
Call (408) 245-3000.

WRQ CIRCLE 263

Makers of Reflection Series Software. HP terminal emulation for PCs and Macintoshes.
Call (800) 872-2829.

*The publisher does not assume any liability for errors and omissions.

UNIX is a registered trademark of AT&T in the U.S.A. and in other countries.
MS-DOS is a trademark of Microsoft Corp.
Macintosh is a trademark of Apple Computer Inc.
X Window System is a trademark of MIT.
Windows is a registered trademark of Microsoft Corp.
Windows NT is a registered trademark of Microsoft Corp.
NetWare is a registered trademark of Novell Inc.

HP Professional

1300 Virginia Dr., Ste. 400
Fort Washington, PA 19034
(215) 643-8000 FAX (215) 643-8099

and Microsoft Gateway/SNA Server are supported. File transfer is handled via Zmodem, Kermit and ASCII. Contact UniPress Software, 2025 Lincoln Hwy., Edison, NJ 08817; (908) 287-2100; info@unipress.com; www.unipress.com.

Circle 394 on reader card

ACUCOBOL-GT Available For Windows

Acucobol Inc. announced the availability of ACUCOBOL-GT for Microsoft Windows 3.1, Windows NT and Windows 95 environments. It enables programmers to implement and deliver full-featured GUI COBOL applications. Programmers can create graphical applications including native floating windows and graphical controls (such as text entry fields, list boxes, push buttons, toolbars and labels) using COBOL extensions that are consistent with traditional COBOL syntax and methodologies.

Contact Acucobol Inc., 7950 Silverton Ave., Ste. 201, San Diego, CA 92126; (619) 689-7220; info@acucobol.com; www.acucobol.com.

Circle 384 on reader card

Lund Provides Toolbox For System Managers

Lund Performance Solutions released System Manager's Toolbox, software that manages tasks such as: finding text strings in files; copying MPE, KSAM and Turbo-IMAGE files; analyzing memory contents; and eliminating idle users. It also includes a terminal-based windowed, interactive file manager, simple MPE/iX interactive time and date altering without rebooting, extensive memory analysis capabilities, and comprehensive and flexible process monitoring. The System Manager's Toolbox runs under MPE/iX and costs \$2,995.

Contact Lund Performance Solutions, 428 Second Ave. SE, Albany, OR 97321; (541) 926-3800; info@lund.com; www.lund.com.

Circle 379 on reader card

HARDWARE

Shark Multimedia Offers Tiger-288R, Baby Tiger-288R

Shark Multimedia shipped the Tiger-288R and Baby Tiger-288R. These cards implement Digital Simultaneous Voice and Data

technology, letting users share applications and data files while speaking on the same telephone line.

The Baby Tiger-288R includes a 28.8 Kbps modem for access to the Internet or any online service, as well as a 14.4 Kbps fax and full duplex speaker phone with voicemail features.

The Tiger-288R also features radio audio capabilities that are SoundBlaster-compatible. Users get CD-quality 8- and 16-bit record and playback. It has joystick, microphone and speaker line out ports, and an IDE CD-ROM interface.

Price is \$239 for Baby Tiger-288R and \$289 for Tiger-288R. When bundled with optional Media Ring Plus software, the Baby Tiger costs \$279 and the Tiger costs \$339. Contact Shark Multimedia, 3040 Oakmead Village Dr., Santa Clara, CA 95051; (408) 987-5420; www.sharkmm.com.

Circle 373 on reader card

Mannesmann Tally Offers T9012 Printer

Mannesmann Tally introduced the T9012, a 12 ppm laser printer capable of outputting 600 dpi text, graphics and gray-



GE Capital Computer Rental Services

Our Business Is Helping Yours®

UNIX Workstation Rentals

Now's the Time to Rent the Newest UNIX Workstations!

- Cost-effective rental of the latest HP, Silicon Graphics, Sun, and Tadpole workstations:
 - HP C Class
 - HP Model 715
 - HP Model 735
 - Silicon Graphics Indy™
 - Silicon Graphics Indigo2™
 - Sun SPARCstation 5
 - Sun SPARCstation 10
 - Sun SPARCstation 20
 - Sun Ultra 1 Systems
 - Tadpole SPARCbook

Plus new products available as released by manufacturers!

- Large inventory - Fast delivery
- Flexible rental & leasing options-Rent-to-Own
- Major credit cards accepted

Call 1-800-GE-RENTS!

Authorized Rental Company For:

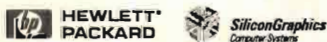

TADPOLE TECHNOLOGY



CIRCLE 166 ON READER CARD

What Do These Clients/Servers Have In Common ?

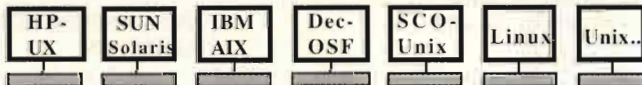

Downtime

WatchDog-HA. The Reliable, Affordable Route To High Availability. WatchDog-HA helps eliminate costly downtime by notifying administrators of potential application, system, and network problems and automatically recovers your system from failures. WatchDog-HA's flexible API enables administrators to write scripts or programs and interface with its server for corrective actions. WatchDog-HA high availability and failure management software maximizes application and system availability for disaster-recovery.

Relax, WatchDog-HA is "On Duty".

www.protocols.com

800-797-2PPC

T:415-433-2763/201-279-5495

F:415-433-5527/201-279-5497

E-Mail: sales@protocols.com

Professional Protocol, Corp.



Channel Partner

All trademarks are trademarks of their respective owners.

CIRCLE 298 ON READER CARD

New From HP

HP JetDirect EX Plus3-100VG — HP introduced a print server that supports high-speed 100VG AnyLAN networks. The HP JetDirect EX Plus3-100VG external print server completes HP's 100VG workgroup product line, which includes hubs, switches, routers, LAN adapter cards and network management software.

Features include: support for 100VG AnyLAN or 10 Mbps Ethernet LANs; high data throughput (220 KBps); three high-speed Bi-Tronics Parallel ports; support for leading network operating systems, including NetWare Directory Services (NDS) support for Novell NetWare 4.1 and Windows NT; true multiprotocol support; 1 MB Flash memory; HP JetAdmin software; and automatic reset after network failure. Price is \$649.

HP Vectra XM Series 4 PC — HP announced a network-ready PC, the HP Vectra XM Series 4 PC. This Pentium-based PC can be turned on remotely from anywhere on an Ethernet LAN (a feature HP calls LAN Remote Power). It includes performance enhancements, such as EDO RAM, 256 KB synchronous pipeline burst cache and HP's power-on-from-the-keyboard design. Processors range from the 166 MHz to the 75 MHz Pentium processors.

The HP Vectra XM Series 4 has a built-in Ethernet PCI interface and standard multiprotocol boot-ROM. It also includes industry-standard DMI agents for Windows 95, Windows for Workgroups and OS/2 clients, as well as management support for HP OpenView, Microsoft SMS and Intel LANDesk consoles.

Prices vary depending on configuration.

For more information, contact your local sales office or call (800) 533-1333.

shades. The print quality is further refined with Edge Enhancement Technology (EET) for smoother edges and elimination of "stair stepping." It has a duty cycle of 30,000 page per month. The T9012's 2 MB memory is expandable up to 32 MB using 1, 2, 4 and 8 MB plug-in SIMM modules. Price is \$1,590.

Contact Mannesmann Tally Corp., 8301 S. 180th St., Kent, WA 98064; (206) 251-5500; www.tally.com.

Circle 361 on reader card

Procom Provides LDLT280G

Procom Technology Inc. introduced a DLT library subsystem that provides up to 280 GB of storage. The LDLT280G can back up data unattended at a sustained transfer rate of 3 MBps. After connecting the unit to the network with a single SCSI cable, network administrators load up to seven 40 GB (assuming 2:1 data compression) Compact-Tape IV media into a magazine and insert the magazine into the unit. The LDLT280G loads and unloads each cartridge in about 29 seconds, either randomly or sequentially, into the single drive. Price is \$12,995.

WE DON'T MAKE REPORTS. WE MAKE THEM APPEAR WHEN AND WHERE THEY ARE NEEDED . . . FAST! ON USERS' PCs OR NETWORK PRINTERS.

 **REVEAL/CS™ DELIVERS THE REPORTS USERS NEED, WHEN AND WHERE THEY NEED THEM.** ACCORDING TO FORTUNE 500 FINANCIAL CORPORATION, "REVEAL/CS PROVIDES A MORE FUNCTIONAL WAY FOR USERS TO VIEW REPORTS." NOT ONLY DOES REVEAL/CS ALLOW ON-LINE VIEWING; BUT IT ALSO PROVIDES AUTOMATIC REPORT DISTRIBUTION TO NETWORK PRINTERS.

 **WITH THE POWERFUL WINDOWS® INTERFACE OF REVEAL/CS, USERS CAN INSTANTLY AND SIMULTANEOUSLY ACCESS SEVERAL CORPORATE REPORTS LOCATED ON DIFFERENT SERVERS. NO MORE PAPER CUTTING, BURSTING, SHIPPING, PILING AND DISPOSING. CUT PAPER COST. CUT DISTRIBUTION TIME. CUT SUPPORT COSTS.**

 **THE UNIQUE PINPOINT DISTRIBUTION™ AND SECURITY ENGINE OF REVEAL/CS AUTOMATICALLY TARGETS THE DELIVERY OF REPORTS TO THE RELEVANT USERS OR DIRECTLY TO NETWORK PRINTERS.**

PAGE-LEVEL SECURITY ENSURES THAT QUALIFIED STAFF WILL REVIEW ONLY APPROPRIATE INFORMATION.

 **USERS CAN GRAPHICALLY EXTRACT THE DATA THEY NEED FROM LARGE REPORTS AND CREATE SUB-REPORTS SPECIFIC TO THEIR NEEDS. REPORTS AND SUB-REPORTS CAN THEN BE EXPORTED PROMPTLY TO SPREADSHEETS.**

 **ACT NOW TO MAKE REPORTS APPEAR ON YOUR USERS' DESKS . . . FAST! CALL THE COMPANY THAT INVENTED ON-LINE VIEWING IN THE HEWLETT-PACKARD WORLD AND SEE FOR YOURSELF HOW EFFICIENT REVEAL/CS IS ON THE HP9000, THE HP3000 AND THE RS/6000.**

 **FOR A FREE 90-DAY REVEAL ROADMAP TO SUCCESS DEMO, PLEASE CALL O'PIN SYSTEMS NOW AT (612) 883-2888 AND ASK FOR ONE OF OUR REPORT DISTRIBUTION CONSULTANTS.**

 **O'PIN SYSTEMS**

INTERNATIONAL PLAZA, SUITE 635 • 7900 INTERNATIONAL DRIVE
BLOOMINGTON, MN 55425-1510

[HTTP://WWW.OPIN.COM](http://www.opin.com)

CIRCLE 258 ON READER CARD

Why store, collate & distribute pre-printed forms, when there's FormsXpress?

Save 80% by Designing Forms, Merging Data & Distributing Documents Electronically!

Xpoint's FormsXpress is the top electronic forms, barcode label and laser check printing software. It saves you time and money by handling all your form and label requirements including:

- Merging customer data from your primary application software without application reprogramming
- Printing forms in order, eliminating manual collating
- Creating industry standard barcodes, including UCC, UPC and PostNet Plus 4
- Electronically distributing forms using laser or thermal printing and automated faxing technologies

For more information: 770-446-2764
Reseller Inquiries Welcome!

xpoint corporation
3100 Medlock Bridge Rd.
Suite 370
Norcross, GA 30071

FormsXpress
The Professional's Trackball
Phone: 770-446-2764 Fax: 770-446-6129
email: info@xptcorp.com

CIRCLE 227 ON READER CARD

ADVERTISING SALES OFFICES

Leslie Ringe, Publisher
(215) 643-8070

EAST COAST (215) 643-8070

Leslie Ringe,
Regional Sales Manager
1300 Virginia Drive, Suite 400
Fort Washington, PA 19034
FAX (215) 643-8099

MIDWEST/SOUTHCENTRAL (215) 643-8063

Gloria Goodwin,
Regional Sales Manager
1300 Virginia Drive, Suite 400
Fort Washington, PA 19034
FAX (215) 643-2143

NORTHWEST/SOUTHWEST (510) 595-2140

Luisa Perticucci,
Regional Sales Manager
6400 Hollis Street
#4
Emeryville, CA 94608
FAX (510) 595-2148

EUROPE 33 42 93 27 63

Fran Grega,
European Sales Manager
Villa Bourguet
Chemin de la Fourane
13090 Aix-en-Provence France
FAX 33 42 27 21 17

Cheryl DeMaioribus,
Marketing Services Manager
Lisa Merck, Card Deck Manager
Cathy Dodies, List Rental Manager
Lisa Merck,
Product Showcase Sales Manager



Professional
1300 Virginia Dr., Ste. 400
Fort Washington, PA 19034

(215) 643-8000
FAX (215) 643-8099

Four of the top trading houses on Wall Street use MOUSE-TRAK.

Productivity and reliability persuaded these businesses to replace hundreds of free mice that came with their workstations with \$199 MOUSE-TRAK™ trackballs.

Productivity: Laboratory testing has shown that only 4 hours of continuous mouse usage can result in as much as 60% loss of hand strength. A trader in that condition is simply not going to make as many trades per hour in the second half of the day as in the first. The same tests show no signs of physical fatigue when using a MOUSE-TRAK.

Reliability: MOUSE-TRAK's rugged construction results in *much* higher reliability than mice or consumer trackballs. MOUSE-TRAK doesn't take traders out of play or make support people pull their hair out!

Call today to order or receive a copy of our analysis of the benefits of a MOUSE-TRAK versus a free mouse.

1-800-533-4822
sales @ moustrak.com

mouse-trak

The Professional's Trackball!



ORDER TOLL FREE 1-800-533-4822

ITAC Systems, Inc. 214 494-3073 Fax 214 494-4159
www.moustrak.com

MOUSE-TRAK is manufactured in the U.S.A. by ITAC Systems, Inc.,
3113 Benton Street, Garland, Texas 75042 Patented by ITAC Systems, Inc.
MOUSE-TRAK is a registered trademark of ITAC Systems, Inc. Other brand and product names are trademarks of their respective holders.

CIRCLE 107 ON READER CARD

Contact Procom Technology, 2181 Dupont Dr., Irvine, CA 92715; (714) 852-1000; info@procom.com; www.procom.com.

Circle 359 on reader card

Multi-Tech Systems Supports 33.6 Kbps Modems

Multi-Tech Systems Inc. announced support for the ITU Study Group 14 modem standard, which provides a top speed of 33.6 Kbps, and implements technical enhancements that allow for higher connect rates over a broad range of possible phone line conditions.

Multi-Tech also announced the addition of a new model to its MultiModemZDX product line — Model Number MT2834ZDXb. Price is \$399. In addition, Multi-Tech will enable existing V.34 MultiModemZDXs to be upgraded for \$24.95. The following will ship with the enhanced speed capability: MT2834BA, MT2834BL, MT2834BR, MT2834BLR and MT2834MR.

Contact Multi-Tech Systems, 2205 Wooddale Dr., Mounds View, MN 55112; (612)785-3500; www.multitech.com.

Circle 371 on reader card

Bit 3 Releases PCI Expansion Unit

Bit 3 Computer Corp. announced the Model 2101-00-2 PCI 19-inch Rackmount Expansion Unit to transparently add seven 32-bit PCI slots to a PCI slot-limited host computer. Throughput to 132 MBps and zero wait state burst operations are supported. It consists of a Bit 3 host PCI card and a 19-inch rackmount cabinet. The expansion cabinet includes: a backplane controller card, an eight-slot PCI baby AT size backplane, a 250 watt power supply and the EMI-shielded chassis itself. A two- or four-foot cable connects together the host PCI card and the cabinet. Short or long +5V PCI cards can be used. Each slot in the cabinet can be a master or slave. Price is \$995. Contact Bit 3, 8120 Penn Ave. S, Minneapolis, MN 55431; (612) 881-6955; sales@bit3.com; www.bit3.com.

Circle 367 on reader card

Verbatim Features MC-3020-EX

Verbatim Corp. shipped MC-3020-EX, the second of its QIC-EXtra products which feature immediate increased capacity for existing QIC drives and cross-platform compatibility with new drives including Travan style drives. The MC-3020-EX minicartridge offers 3.2 GB of compressed storage capacity.

Contact Verbatim Corp., 1200 W.T. Harris Blvd., Charlotte, NC 28262; (704) 547-6500; lhealy@verbatimcorp.com; www.verbatimcorp.com.

Circle 362 on reader card

Micom Supports ITU Standard

Micom Communications Corp. announced that its Marathon Integration Multiplexer and NetRunner Integration Router product lines support the International

Telecommunication Union's (ITU) G.729 8 Kbps voice compression standard. The ITU standard forms the core of Micom's ClearVoice technology suite which includes voice switching, fax demodulation, echo cancellation, silence suppression and dynamic bit rate adaption technologies.

Contact Micom, 4100 Los Angeles Ave., Simi Valley, CA 93063; (805) 583-8600; www.micom.com.

Circle 368 on reader card

HP RENTALS

| WORKSTATIONS | | | | | | | | | | |
|--------------|-----|-------------|-----|-----|---------|---------|------|-----|-----|-----|
| 807 | E55 | NEW! | 755 | 750 | CRX | 433 S | CRX | 382 | 360 | 332 |
| 827 | F20 | C110 | 735 | 730 | CRX-24 | 425 T | VRX | 362 | 350 | 330 |
| 847 | G30 | J210 | 725 | 720 | CRX-24Z | 425 S | GRX | 380 | 345 | 320 |
| E25 | H40 | D310 | 715 | 710 | CRX-48Z | 425 E | PVRX | 375 | 340 | 310 |
| E35 | I70 | D350 | 712 | 705 | GRX | 400 S/T | EVRX | 370 | | |
| | | K220 | | | | | | | | |

AND MORE . . .

| | | | | |
|----------------------|---------------------------------|----------------|-------------------------|--------------------------------|
| Printers Plotters | X Terminals APOLLO DN Series | PC's Memory | Discs Test Equipment | 800 Series Data Acquisition |
|----------------------|---------------------------------|----------------|-------------------------|--------------------------------|

TSA is THE place for daily, weekly, monthly or long term rentals of Hewlett-Packard equipment. Ask about our 6-12 month purchase plans. Equipment available for same day shipment.

1-800-422-4872

713/935-1500 • Fax 713/935-1555 • Email: info@tsa.com

Authorized Rental Company

THE RIGHT EQUIPMENT. RIGHT NOW.

2040 West Sam Houston Parkway N. • Houston, Texas 77043

HP RENTALS

CIRCLE 266 ON READER CARD

PRODUCT showcase

HEWLETT
9000 / 3000
•BUY•
•SELL•
•LEASE•
•TRAINING•
•(800)553-0592•

PH: (612) 404-5205
FAX: (612) 404-5243

PACKARD

WORLD DATA PRODUCTS

CIRCLE 486 ON READER CARD

HEWLETT-PACKARD
BUY SELL
RENT REPAIR
9000 1000 3000 TEST
MEMORY - PLOTTERS - PRINTERS
DISC DRIVES - WORKSTATIONS - DATA ACQUISITION

TSA
THE RIGHT EQUIPMENT. RIGHT NOW.
2040 West Sam Houston Parkway N. • Houston, Texas 77043

1-800-422-4872
713/935-1500 FAX 713/935-1555

CIRCLE 228 ON READER CARD

Remanufactured HP 9000 Servers, Workstations

Workstations
INTERNATIONAL
Serious HP Solutions
HP 9000

QUALITY REMANUFACTURED SYSTEMS
SCIENTIFIC WORKSTATIONS
BUSINESS SERVERS
FULL 90 DAY WARRANTY
QUICK TURNAROUND

Large HP inventory IN STOCK
1-800/842-4781
Call for ALL your HP needs!

601 Lakeshore Parkway, Suite 1160, Minnetonka, MN, USA, 55305
612 / 449 - 9000 PH 612 / 449 - 3198 FAX
e-mail: info@workstations.com

Printers / Plotters, Network Hardware

CIRCLE 458 ON READER CARD

HEWLETT-PACKARD

1000 • 3000 • 9000

BUY • SELL • RENT • LEASE
MAINTENANCE
PROCESSORS • PERIPHERALS • SYSTEMS

EURODATA INC.
(613) 745-0921
Fax: (613) 745-1172
2574 Sheffield Road, Ottawa, Canada K1B 3V7

CIRCLE 283 ON READER CARD

Wanted: Authors

Publisher seeks computing experts to write books. Topics of interest include:

- Migrating from MPE/HP 3000 to HP-UX/9000
- Encino/9000 Transaction Monitors
- HP's OpenMail, OpenWarehouse, or SoftBench Programming
- Document Imaging with HP 3000 and HP 9000
- System/Network Management
- UNIX and PCs
- DCE Applications

Call Laura Derr for information at
(215) 643-8104 or
derrll@box101.cardinal.com

CBM BOOKS 1300 Virginia Drive, Suite 400
Fort Washington, PA 19034

<http://home.navisoft.com/csi6000>

HP HEWLETT PACKARD
Channel Partner

Reflection
VRQ AUTHORIZED VAR

- Expert Pre-Sale Consultation
- New HP Business Systems
- Integration of PC Networks
- Systems Integration
- Rentals And Outsourcing
- Disaster Recovery Services

Computer Solutions, Inc.
201-672-6000

CIRCLE 209 ON READER CARD

MONTEREY BAY COMMUNICATIONS
The HP 1000/9000 Specialists

Huge Inventory

MBC
MONTEREY BAY COMMUNICATIONS

TEL: 408/429-6144
FAX: 408/429-1918
1010 Fair Avenue
Santa Cruz, CA 95060

CIRCLE 229 ON READER CARD

ST. PAUL SOFTWARE'S
EDI Solutions
for Unix, Midrange, Mainframe, PC

- Powerful EDI Translation
- GUI Visual Mapping
- Flexible Scheduling
- Application Integration to Oracle, SAP, C.A-MANMAN and others

for HP 3000 and HP 9000

ST. PAUL SOFTWARE
3450 EMBURY PARK DR. ST. PAUL, MN 55108
TEL: 612/465-4400 FAX: 612/463-4403
SALES: 800/998-4EDI (4374)

WWW <http://www.spedi.com> Email info@spedi.com

CIRCLE 465 ON READER CARD

HEWLETT PACKARD

Depot Repair

- Expert Depot Repair
- 5 Day Turnaround
- Emergency Exchange Program

BLACK RIVER
COMPUTERS

1-800-837-0061
216-365-9950 Ohio
216-365-3916 FAX

CIRCLE 158 ON READER CARD

PRODUCT showcase



I/O Data Systems, Inc.

Buy - Sell - Lease - Trade
HEWLETT-PACKARD
 Systems, Workstations
 Peripherals, Solutions

(216) 835-2211
 27378 W. Oviatt
 Bay Village, OH 44140
 FAX: (216) 835-0220

HP Channel Partner

CIRCLE 272 ON READER CARD

NORCO COMPUTER SYSTEMS, INC.
*Hewlett-Packard Quality
 at a NorCo Price*

1000 • 3000 • 9000 • 700

**BUY—SELL
 TRADE—LEASE**
 Processors, Peripherals
 and Systems

21337 Drake Road
 Cleveland, OH 44136-6620
 FAX: 216-572-0636
216-572-4040 1-800-892-1920
 (Outside Ohio)

CIRCLE 221 ON READER CARD

Surety systems, Inc.

**Hewlett Packard Equipment
 And Maintenance Services**

- HP 9000
- HP 3000
- HP 700 Series Workstations
- HP Peripherals

(713) 466-9455
 A World Apart. A Phone Call Away.

HP Channel Partner COMPUTER ASSOCIATES Software specialist by design CA-Uniscanter Advanced Matrix Technology

Houston, TX. FAX (713)466-9454

SURETY SYSTEMS, INC. 1. services, certainty, 2. security, against loss or damage, 3. one who makes himself responsible for another's syn. assurance, commitment, bond, earnest, guarantee, pledge, security.

CIRCLE 226 ON READER CARD

OUR 10th YEAR

QUALITY HP EQUIPMENT WITHOUT THE HP PRICE

DON'T UPGRADE YOUR HP SYSTEM UNTIL YOU GET A SECOND OPINION FROM THE SECOND SOURCE FOR HEWLETT-PACKARD 1000-3000-9000 EQUIPMENT

Consult with us about cost-saving alternatives

- Complete Configurations
- Individual CPUs-Peripherals
- Memory Upgrades and Feature Enhancements
- Classic and Spectrum Equipment

WE BUY
 Highest Prices Paid

WE SELL
 *All Items Sold Are Guaranteed for HP Maintenance
 *Short and Long Term Leases Available

WE TRADE
 Over 1000 satisfied Hewlett-Packard users are our customer references throughout the United States, Canada, Europe, and the Far East.

C.S.U. Industries, Inc.
 395 Pearsall Avenue, Cedarhurst, NY 11516
 Ask for Mord: **(516) 239-4310**
FAX (516) 239-8374



CIRCLE 205 ON READER CARD

TED DASHER & ASSOCIATES

HEWLETT-PACKARD 9000 SPECIALIST

We Remarket HP

| | | |
|--------------------------|---------------------|-----------------|
| PLOTTERS | WORKSTATIONS | PRINTERS |
| DesignJet 200 Series | LaserJet | |
| Desktop 300 Series | DeskJet | |
| DraftPro 400 Series | Rugged Writer | |
| DraftMaster 700 Series | ThinkJet | |
| Electrostatic 800 Series | PaintJet | |

VECTRA PERSONAL COMPUTERS - NETSERVERS - SCANNERS
 FAX MACHINES - DISPLAYS - MAC PRINTERS - LAPTOPS
 ALL EQUIPMENT IS REFURBISHED AND CARRIES A 90 DAY WARRANTY

4117 2ND AVENUE SOUTH BIRMINGHAM, AL 35222
800-638-4833
PHONE 205-591-4747
FAX 205-591-1108
EMAIL sales@dasher.com

HP Channel Partner

CIRCLE 233 ON READER CARD

H · I · C · M · P
A M E R I C A I N C .

The Premier Network Backup Engine

HIBACK/UX HIBACK/NT
HIBACK/iX HIBACK/Win95
HIBACK/SUN HIBACK/UNIX

Supports: M/O disc, tape, QIC, DLT, DDS, autoloaders, stackers, StorageTek, Exabyte

The only SAP Complementary Software Partner with a Certified Interface for UNIX and NT SAP R/3 backup

<http://www.hicomp.com/hicomp>
 P.O. Box 2959, Spring TX 77383
(800) 323-8863 Intl: (713) 288-7438
 Europe: +49 (40) 638 09 0

CIRCLE 217 ON READER CARD

WE MANUFACTURE HP Accessories

Trackballs

Bar Code Readers

Data Collection Terminals

BKS electronique

20 rue A. Berges/ZI des lles
 F-38800 Le Pont de Claix
FRANCE
 Tel: +33 76 98 30 99
 Fax: +33 76 98 57 79

... AND MORE !

CIRCLE 493 ON READER CARD

CONSULTANT showcase

SWC Consulting, Inc. **SPEEDWARE**
Business Partner

Immediate Job Openings

SW Consulting, Inc. has immediate openings for candidates with the following HP3000 experience:

Speedware Cobol Turbo Image Omnidex/Imsum

Salaries for professionals with one or more of these skills range from **\$55k - \$85k/yr** If you have any of these skills and are not earning top dollars for your knowledge and would like to pursue a career as an Information Systems Consultant, then mail or fax your resume to:

SW Consulting, Inc.
 13180 N Cleveland Avenue Phone: (800) 494-4977
 Suite 112 (941) 656-1011
 N. Ft. Myers, Florida 33903 Fax: (941) 997-0456

We offer relocation packages and signing bonuses to consultants who qualify.

CIRCLE 255 ON READER CARD

CAREER opportunities

HP PROGRAMMING CAREERS!

The Golden Gate Bridge, Highway & Transportation District seeks professionals to direct all systems design & programming projects in an HP1000 & HP3000/Novell Netware environment.

Supervising Programmer Analyst
 (\$55,984 - \$67,645/yr. + benefits)

Systems Programmer
 (\$50,914 - \$61,542/yr. + benefits)

To request an application & detailed job description, call **(415)257-4526**.

Resumes are NOT accepted in lieu of a completed application, EOE

Get Smart, Defeat Chaos



Mandeep Khera
Worldwide
Operations
Manager,
HP's Asset
Management
Operation

Around the globe, there are 400 million to 500 million PCs, printers and other computing peripherals just sitting out there on the desktop. And it's not slowing down. For example, the installed base of PCs in the United States is expected to grow by 25 million this year. In the glass house days, keeping track of these technology assets wasn't difficult — you knew they were right there in the data center. But thanks (if that is the right word) to the decentralizing effects of client-server technology, corporate desktops are now teeming with technology assets.

WHERE, OH WHERE CAN THEY BE?

Experience has shown that most companies underestimate their technology assets by 50 percent to 75 percent. One U.S. bank was supposed to have 800 PCs in one department. An audit found nearly 1,200. Another U.S. bank was operating under the assumption that there were 1,200 desktops and 40 servers in two office buildings. A recent audit revealed 1,850 desktop assets and 143 servers. Although common, these inaccuracies are costly.

Asset management can help. Asset management is a *business discipline* that tracks an organization's technology resources to ensure that they are being properly used and that the organization is getting an optimal return on expenditures. Asset management, which companies can do themselves with asset management software or outsource to another company, helps with technology standardization and internal charge-backs, as well as service and support.

In a desktop environment, an asset management solution provides information on the following: all assets, including their location, use and users; software licensing and hardware configurations; linkages to other management applications; acquisition costs; maintenance requirements, support costs, service history and support contract renewal; movement of, and changes to, the asset base; and lease contracts, such as term, expiration date, renewal date, return date and residual values. With accurate, easily accessible information, companies can control costs, improve planning, avoid software license penalties and optimize asset use. Asset management

can help in the following ways:

- **Easier migration to new technologies.** Asset management can help companies negotiate volume discounts on new technologies and services.
- **Lower maintenance costs.** Companies can lower their maintenance costs 25 percent to 50 percent by avoiding maintenance contracts on idle assets or on assets still under warranty.
- **Tighter management of software licenses.** Asset management helps companies avoid buying too many licenses and the penalties (which can range up to \$100,000) for having pirated software.
- **Optimized asset use.** Based on usage information, customers can determine whether a given user has too little or too much desktop processing power and can adjust accordingly.
- **Better allocated costs.** Tracking utilization of assets allows IT to charge back costs to departments or groups using the assets.
- **Lower taxes.** With more accurate information about their assets, companies can reduce their property taxes and depreciation on unused assets.
- **Improved cash flow.** Companies can improve their cash flow by disposing of excess equipment.
- **Better sales force automation.** Companies can better track and upgrade the sales force equipment.

THE RIGHT STUFF

An asset management solution lets you see what you have, who is using it, how it is configured, what you paid for it and more. When you can see exactly what technology assets you have and the total cost of ownership, you can streamline your assets, make them work together, and plan for future investments and upgrades. An asset management solution will provide the basis for significant savings, will boost productivity and will improve overall return. Asset management is not a panacea, but it helps you regain control of your technology. —Mandeep Khera is the worldwide operations manager for HP's Asset Management Operation, based in Mountain View, Calif. A former part-time editor, he still likes to try his hand at the writing trade.

The DynaComm Connectivity Series

Enterprise-Wide Computing

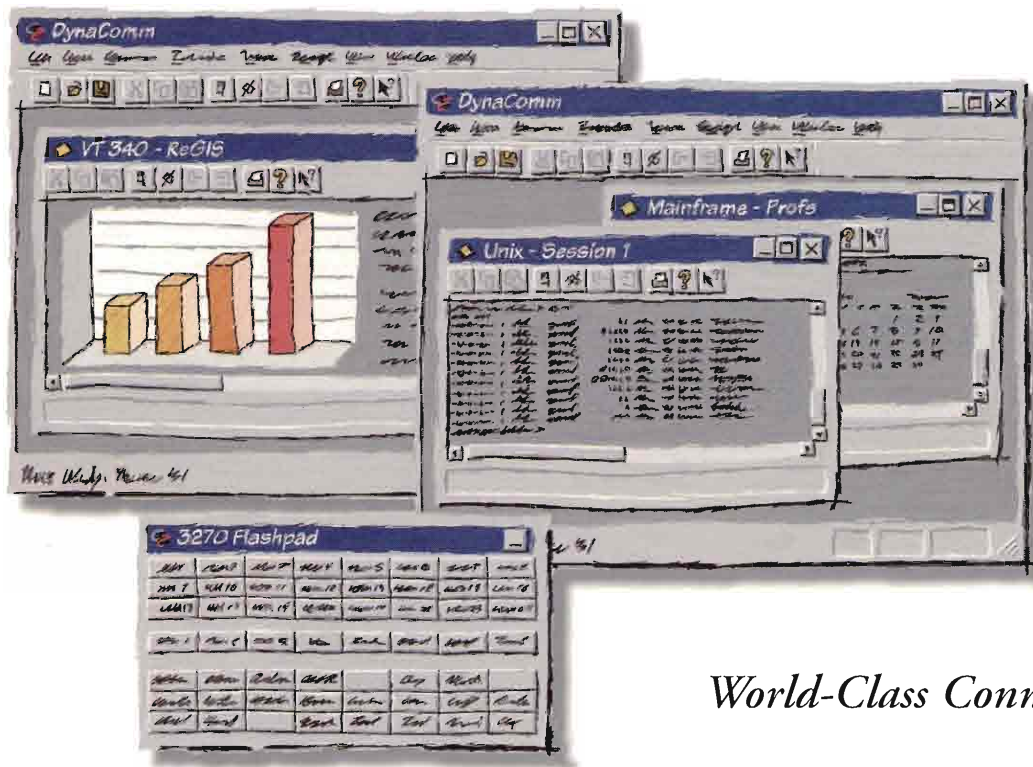

World-Class Connectivity

The DynaComm® Connectivity Series provides comprehensive terminal emulation and complete network connectivity for accessing the most popular host systems.

With the all new modular design, the DynaComm Connectivity Series allows you to create a host access emulation system that will fit your particular need. The DynaComm Connectivity Series starts with the core module which contains numerous standard emulations, full network connectivity and a world-renowned scripting development environment.

Added to the core module are DynaComm client options for almost any type of host including advanced DEC, DG, HP, IBM and Tandem. Simply by adding the DynaComm client option(s) that you need, you will have a customized connectivity solution at your fingertips. A single executable instance of the product supports multiple sessions (both asynchronous and synchronous).

Multi-platform support is also available. With versions for both 16- and 32-bit platforms, the DynaComm Connectivity Series will be equally at home on Windows® 95, Windows® NT™ and Windows® 3.x. The consistent user interface and functionality across all operating systems facilitates easy migration and reduced training and support costs.

Major New Features Include:

- A single executable instance for multiple emulation sessions (asynchronous and synchronous)
- OLE compliance
- Windows 95 and Office 4.x "look and feel"
- Add-on emulation client options that provide "plug-and-play" capability to fit virtually any host environment requirements
- Consistent scripting language compatible across all emulations

DynaComm
by **FutureSoft**

12012 Wickchester Lane, Suite 600 • Houston, TX 77079
(713) 496-9400 • Fax (713) 496-1090
Nijverheidsstraat 12 • 2288 BB Rijswijk • The Netherlands
31-70-390-7727 • Fax 31-70-390-7005
Internet: info@fse.com or <http://www.fse.com>

For More Information Call: 1-800-989-8908

© 1986-1996 Future Soft Engineering, Inc. DynaComm, FutureSoft and Future Soft Engineering are registered trademarks of Future Soft Engineering, Inc. Microsoft and Windows are either registered trademarks or trademarks of Microsoft Corp. in the United States and/or other countries. All other trademarks are the properties of their respective owners or licensors.

CIRCLE 190 ON READER CARD

Q3/96-4Q4/93

MONDAYS,
AS DESIGNED BY
NETWORK PROFESSIONALS.

ENTERPRISE-WIDE
CONNECTIVITY, AS DESIGNED
BY NETWORK PROFESSIONALS.

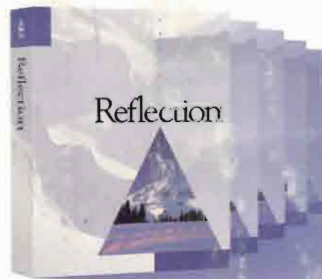

If it were up to you, your hard work would finally pay off. Mainframes, PCs, minicomputers and servers would all fit together seamlessly, and Monday would be just another day at the beach.

Impossible? Not with Reflection® from WRQ. Reflection offers complete, integrated PC connectivity software for your entire enterprise—including transport protocols, PC X server software, and terminal emulation. All with the management features, open standards, and service and support you need.

To try connectivity designed from your point of view, call today for a free evaluation copy. We'll make sure that from here on out, your Mondays go swimmingly.

For a **FREE** evaluation copy,
of any Reflection® product, call
800.926.3896

WRQ Reflection
CONNECTIVITY FOR A CHANGING WORLD

REFLECTION® SOLUTIONS

REFLECTION PC-TO-HOST CONNECTIVITY SOFTWARE

- ▲ UNIX, X, HP, DIGITAL, AS/400 AND 3270 CONNECTIVITY
- ▲ WINDOWS, DOS, AND MACINTOSH PLATFORMS
- ▲ INTUITIVE OPERATIONS, FAST FILE TRANSFER, ADVANCED TEXT AND GRAPHICS EMULATION, AND POWERFUL PROGRAMMING TOOLS

REFLECTION NETWORKING SOFTWARE

- ▲ COMMUNICATIONS: TCP/IP, UDP, LAT, NS, VT, IPX/SPX, SLIP, CSLIP
- ▲ ARCHITECTURE: VxD/DLL DESIGN; 100% WINDOWS SOCKETS COMPLIANT
- ▲ FULL-FEATURED APPLICATIONS (FTP, LPR/LPD, INTERNET ACCESS)
- ▲ EASY CONFIGURATION AND MANAGEMENT
- ▲ OPTIMIZED FOR MOBILE/WIRELESS COMPUTING

AVAILABLE AS SUITES AND INDIVIDUAL PRODUCTS, TAILORED FOR ANY ENTERPRISE CONFIGURATION.

CALL 800.926.3896 IN EUROPE, CALL +31.70.375.11.00
OUTSIDE EUROPE, CALL 206.217.7100
INTERNET: sales@wrq.com WEB: http://www.wrq.com

