

HP Professional

AN INDEPENDENT PUBLICATION FOR USERS OF HP COMPUTERS ■ VOL.3 ■ NO.10 ■ \$4.00

OCTOBER 1989

- Workstation
Market Overview

- Cooperative
Computing
HP/Apollo Style

- Real-Time
User Control



INDUSTRY
WATCH

K
T

FOCUS WORKSTATIONS

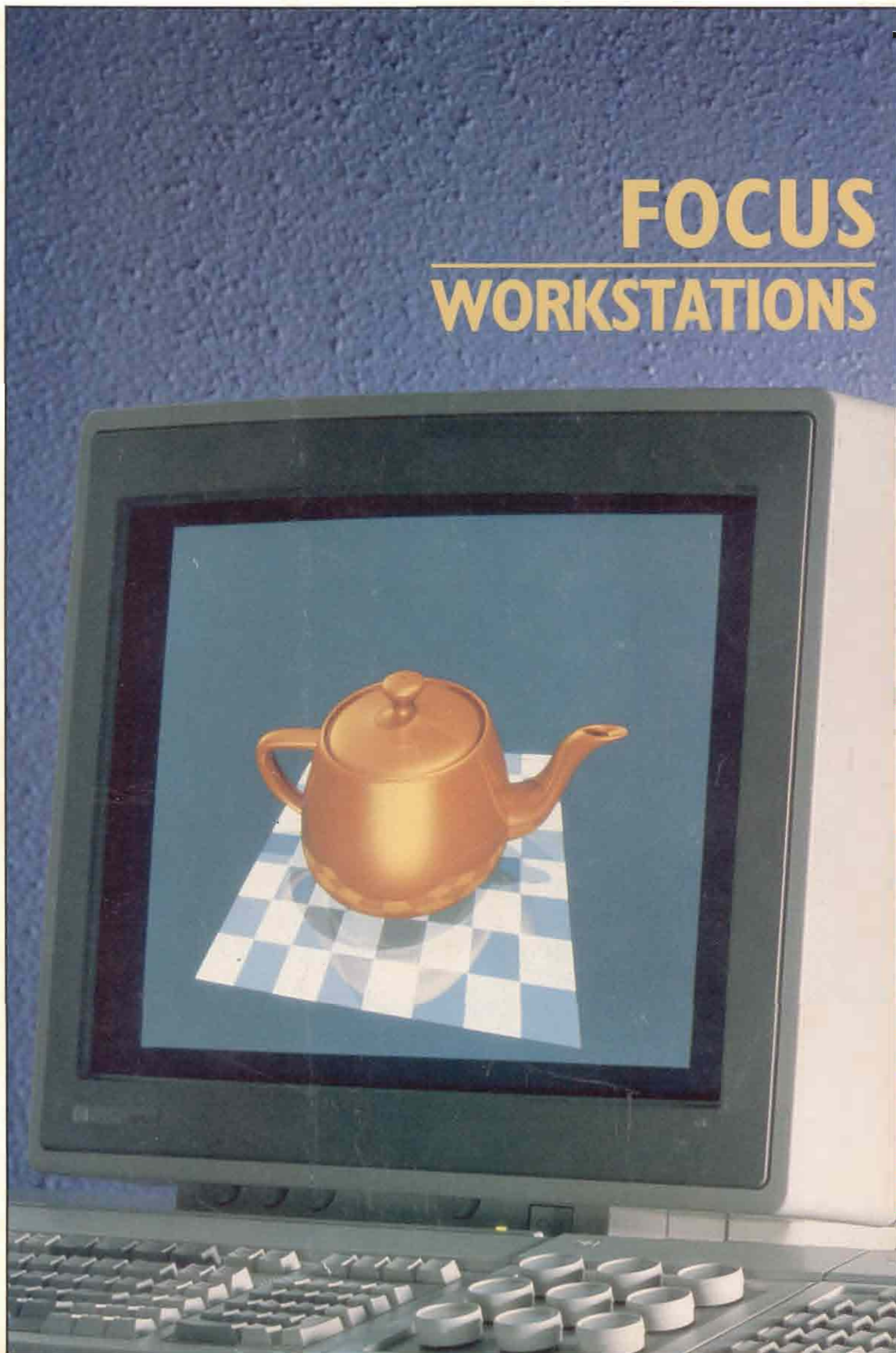

READ A LITTLE HOOPLA. SAVE A LOT OF MOOLA.



Access advanced HP 3000 office information systems.



Precise HP2392 emulation with function key labeling.



Window-based setup allows multiple system configurations.



Keyboard remapping and smart softkeys make it easy-to-use.



Four different text modes: HP, ANSI, EM52, and TTY.



With appropriate PC video card, view full 132-column displays.



Full PC-to-the-rest-of-the-World communications features.



On-line help screens are always just a keystroke away.



Technical support that's unlimited and free.

After reading a list of magnificent features that can reap the enormous benefits of precise PC-to-host connectivity, you might expect SmartTerm® 2392 to carry a whopping price tag. Not true.

At \$99 for a single copy and \$750 for a 10-pack, our 2392 emulation software delivers the best performance-per-dollar ratio in the business. For large sites, our unlimited license at \$9,500 is enough to provoke palpitations.

That's why we've added extra people to take phone orders. So call us today at 1-800-EMULATE.

persoft®

ACCESS THE POWER YOU NEED.



Also easy-to-order.

© 1989 Persoft, Inc. All Rights Reserved. Persoft and SmartTerm are registered trademarks of Persoft, Inc., 465 Science Drive, Madison, WI 53711. Specifications subject to change without notice.

CIRCLE 176 ON READER CARD

DATABASE CAPTIVITY

CONNECTABILITY

COMPATIBILITY

PORTABILITY

HP USERS WON'T TAKE THIS BAIT!

Others may promise Compatibility, Portability and Connectability. But to what? Not to: MPE V, IMAGE, TurboIMAGE, HP SQL, KSAM, MPE, SPL, HP Editors, Utilities, Dictionary/V, System Dictionary, advanced terminal support, not to mention hundreds of 3rd party and HP application packages. In fact, **not** to most of the HP world!

PowerHouse® – number one on HP – doesn't trap you into a "captive" database environment.

PowerHouse works across the most popular HP commercial databases and file systems, allowing you to maximize development performance, while preserving and enhancing your investment in existing HP software.

PowerHouse 4GL doesn't need to call in 3GLs to finish the job.

PowerHouse StarBase™ which integrates with, not attempts to replace HP data sources – will be the most advanced SQL RDBMS on HP.

PowerHouse is the development environment of choice for 8500 HP sites worldwide – including 250 HP VARs, and over 300 licenses within HP itself.

PowerHouse and StarBase – proven application development performance, where it really counts – on HP.

1-800-426-4667*

Performance so powerful that over 300 HP vertical applications have been developed by PowerHouse Partners.

I don't want to be locked out of the HP world!

Please send me information on:

- PowerHouse & StarBase, the HP solution (including a catalogue of over 300 existing commercial applications)
- PowerHouse Partners Program – the best in the business!

Attach business card and mail to: *Cognos Corporation, 2 Corporate Place, I-95 Peabody, MA 01960 or photocopy and FAX to: (508) 535-1328

More than the leading 4GL – the most successful development environment on HP

COGNOS®

*Cognos Incorporated, P.O. Box 9707, 3755 Riverside Drive, Ottawa, Ontario, Canada K1G 3Z4, 1-800-267-2777. In Europe, Cognos Limited, Westerly Point, Market St., Bracknell, Berkshire, RG12 1QB, +44 344 486668. Cognos, PowerHouse and PowerHouse StarBase are registered trademarks of Cognos Incorporated. Other trademarks are the property of their respective trademark holders.

Order From Chaos

Let IEM solve your "mess storage" problems with the ultimate mass storage solution.

Our high capacity intelligent tape system for HP 1000, 3000, and 9000 computers offers up to 2.3 GBytes of storage on a single compact 8mm video cartridge tape. Use it off-line for unattended multiple disk backup (up to 11 MBytes per minute) and restore operations, or on-line as a directly connected tape drive (HP 7974 emulation).

The model ET8200-HP will help you make the most of your limited time and space. Best of all, it is **AVAILABLE NOW!**
From IEM, of course.
CIRCLE 117 ON READER CARD

1-800-321-4671



P.O. Box 8915
Fort Collins, CO 80525
(303) 223-6071 • (800) 321-4671 • FAX (303) 223-4246

Expand Your Horizons

C CONTENTS

OCTOBER 1989

VOL. 3, NO. 10

30 **FOCUS: 3-D Workstations** *by Peggy King*

High-end graphics workstations are intended for use with applications that are more computer-intensive and/or more graphics-intensive than those that run on less expensive workstations. Which one is best for you?

42 **FOCUS: Low-End Workstation Market** *by Bill Sharp*

This marketplace isn't as flashy as the 3-D graphics systems or as beefy as the RISC-based systems, but the fact is that the systems in the low end of the market account for a large percentage of sales.

48 **Real-Time User Control** *by Ted Lupien*

Application Control Library Utilities.

54 **Cooperative Computing** *by Mike Carl*

HP & Apollo Look At A New Way Of Using Computer Resources.

C O L U M N S

FROM THE LAB:

VISIMAGE

by Joel Martin 60

CallBack

by Miles B. Kehoe 66

RDBMS: Error Proneness And

Database Integrity

by Fabian Pascal

Central Inforcement Of Integrity

By The DBMS Is A Must. 70

PC TIPS: MS-DOS Utilities

by Miles B. Kehoe

More Batch File

Programming Techniques. 76

HP-UX: Create Formatted Documents

by Andy Feibus

Defining, Executing And

Utilizing Macros. 80

D E P A R T M E N T S

Editorial 8

ARISTALK 10

Industry Watch 12

News & Trends 16

New Products 24

Product Showcase 92

Consultants Directory 95

Software Directory 95

Advertisers Index 96

Calendar 96



Call For Papers:
Ted Lupien of Du Pont
Co. (Wilmington, Del.)
won second place
in the Call For Papers
Contest for his
article "Real-Time
User Control" (p.48).

On The Cover:
Cover photo courtesy
of Hewlett-Packard.

What is Systems Integration?

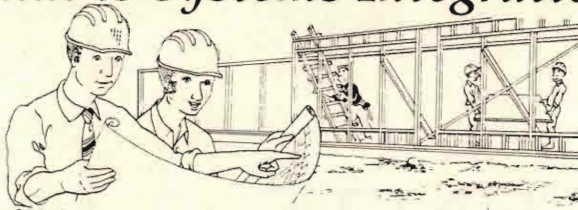

From design to construction...

IISI knows the answer.

Integrating:

- information flow
- software applications
- business demands
- hardware platforms

Working closely with management and end-users, IISI designs and builds a solid systems foundation, provides the needed resources, and constructs integrated systems for your business.



63 Nahatan Street, Norwood, MA 02062
 (617) 769-7511 FAX (617) 762-5164
 Boston, Philadelphia, Washington D.C.

For free project management worksheet, return reader service card.

CIRCLE 188 ON READER CARD



You've fought your last battle with pre-printed forms when you purchase

LASERSOFT™/3000

The electronic forms application for your laser printer
that eliminates pre-printed forms.

For additional information, or to order a demonstration tape,

call or write:

BUSINESS SYSTEMS INTERNATIONAL
 20942 Osborne Street Canoga Park, CA 91304
 (818) 998-7227



CIRCLE 107 ON READER CARD

HP Professional

Publisher: Carl B. Marbach
 Editorial Director: R.D. Mallery

Editorial

MANAGING EDITOR Thomas M. Halligan
COPY EDITOR Andrea J. Zavod
SENIOR TECHNICAL EDITOR David B. Miller
WEST COAST EDITOR Peggy King
CONTRIBUTING EDITOR Bill Sharp
FIELD SERVICE EDITOR Ron Levine
EDITORIAL SYSTEMS COORD. Anne Schrauger
CONTRIBUTORS Mike Carl, Andy Feibus, Miles B. Kehoe, Ted Lupien, Fabian Pascal

DP Laboratory and Testing Center

DIRECTOR R.D. Mallery
MANAGER David B. Miller
TECHNICAL EDITOR George Frueh
REVIEW EDITORS (DEC) Barry Sobel; (HP) Sheldon Green, Miles B. Kehoe, Del Lukens, Joel Martin; (IBM) Bill Davis, Tom Davis
MIS SOFTWARE MANAGER Bonnie Auclair
MIS SYSTEMS MANAGER Kevin J. Kennelly

Design & Production

DESIGN/PRODUCTION MANAGER Ruth Ann Leiby
DESIGN/PRODUCTION ASSOCIATE Pat Messina
ADVERTISING BOOKING COORD. Lori Goodson
ADVERTISING PROD. COORD Suzanne Garr
TRAFFIC/PRODUCTION ASST. Kim Macheski
PROMOTIONS MANAGER Tim Kraft
GRAPHIC DESIGNERS Richard Kortz, Thomas Owen, Sue Ann Rainey
PRODUCTION ARTIST Patricia Kraekel
TYPESETTER MaryEllen Coccimiglio

Circulation

CIRCULATION DIRECTOR Carrie Eisenhandler
CIRCULATION MANAGER Betsy Ellis
FULFILLMENT MANAGER Margie Pitrone
CIRCULATION DBA Rebecca Schaeffer

PROFESSIONAL PRESS, INC.

PRESIDENT Carl B. Marbach
VICE PRESIDENT R.D. Mallery
VICE PRESIDENT Peg Leiby
VICE PRESIDENT Helen B. Marbach
EXECUTIVE EDITOR Linda DiBiasio
EXECUTIVE DESIGN DIRECTOR Leslie A. Canaso
DIRECTOR OF MARKETING Mary Wardlaw
CONTROLLER Andrea Bencke
ASSISTANT TO THE PUBLISHER Jan Knisen

For more information on how to contact your sales representative, see page 96. Editorial, advertising sales and executive offices at 101 Witmer Rd., Horsham, PA 19044 ■ (215) 957-1500
 TWX 910 333 9522 ■ Easylink 62805174
 FAX (215) 957-1050

HP PROFESSIONAL ISSN 0986145X is published monthly by Professional Press, Inc., 101 Witmer Rd., Horsham, PA 19044. Subscriptions are complimentary for qualified U.S. and Canadian sites. Single copy price, including postage \$4. One year subscription rate \$30 U.S. and Canada; \$60 foreign. All orders must be prepaid. Second Class postage paid at North Wales, PA, and additional mailing offices. POSTMASTER: Send all correspondence and address changes to HP PROFESSIONAL, P.O. 616, 101 Witmer Rd., Horsham, PA 19044. COPYRIGHT © 1989 by Professional Press, Inc. All rights reserved. No part of this publication may be reproduced in any form without written permission from the publisher. All submitted manuscripts, photographs and/or artwork are sent to Professional Press, Inc. at the sole risk of the sender. Neither Professional Press, Inc. nor HP PROFESSIONAL magazine are responsible for any loss or damage. HP PROFESSIONAL is an independent journal not affiliated with Hewlett-Packard Company. HP and Hewlett-Packard are registered trademarks and HP PROFESSIONAL is a trademark of Hewlett-Packard Company.



Better HP Workstation Memory

DTACK Systems introduces RAM expansion boards for the HP9000 Model 360, 340 workstations. The unique advantages of MEM360 and MEM340 make them the right choices for you!



Our MEM360 is the most powerful and economical RAM expansion board for all HP 9000 Model 360 workstations. Our MEM360 memory board is unique with its upgrade capability and its 16MByte capacity. The densest RAM board available from Hewlett Packard is only 12MB. Our idea for an upgradable RAM board results from the HP360 having only one connector for add-on memory. If you purchase another style RAM board, you may end up scraping that board and purchasing an entirely new replacement board for future needs. With the DTACK solution, you simply purchase more memory chips for your MEM360 to increase system memory! One MEM360 can expand system memory from 8MB to 20MB.

There are only three things to remember about HP9000 Model 340 system memory: Price; Quality; DTACK Systems. The MEM340 add-on board is built with 4MBytes of RAM. You can cost-effectively add up to 16MB of system memory to your HP340 workstation with MEM340 boards.

Don't wait on other HP RAM board vendors . . . call DTACK Systems, the HP workstation experts, at (714) 998-2244 for more information and factory-direct orders.

"Beyond price and performance advantages of our products is DTACK Systems' uncompromising dedication to the quality and reliability of our products. Our commitment is totally consistent with the product excellence embodied in your HP computer."

Jon Young, President



DTACK
SYSTEMS INC.

Powerful Products Made Simple

120 Chaparral Court, Suite 150, Anaheim Hills, CA 92808 Phone:(714)998-2244 FAX:(714)998-3929

CIRCLE 178 ON READER CARD

At last . . .

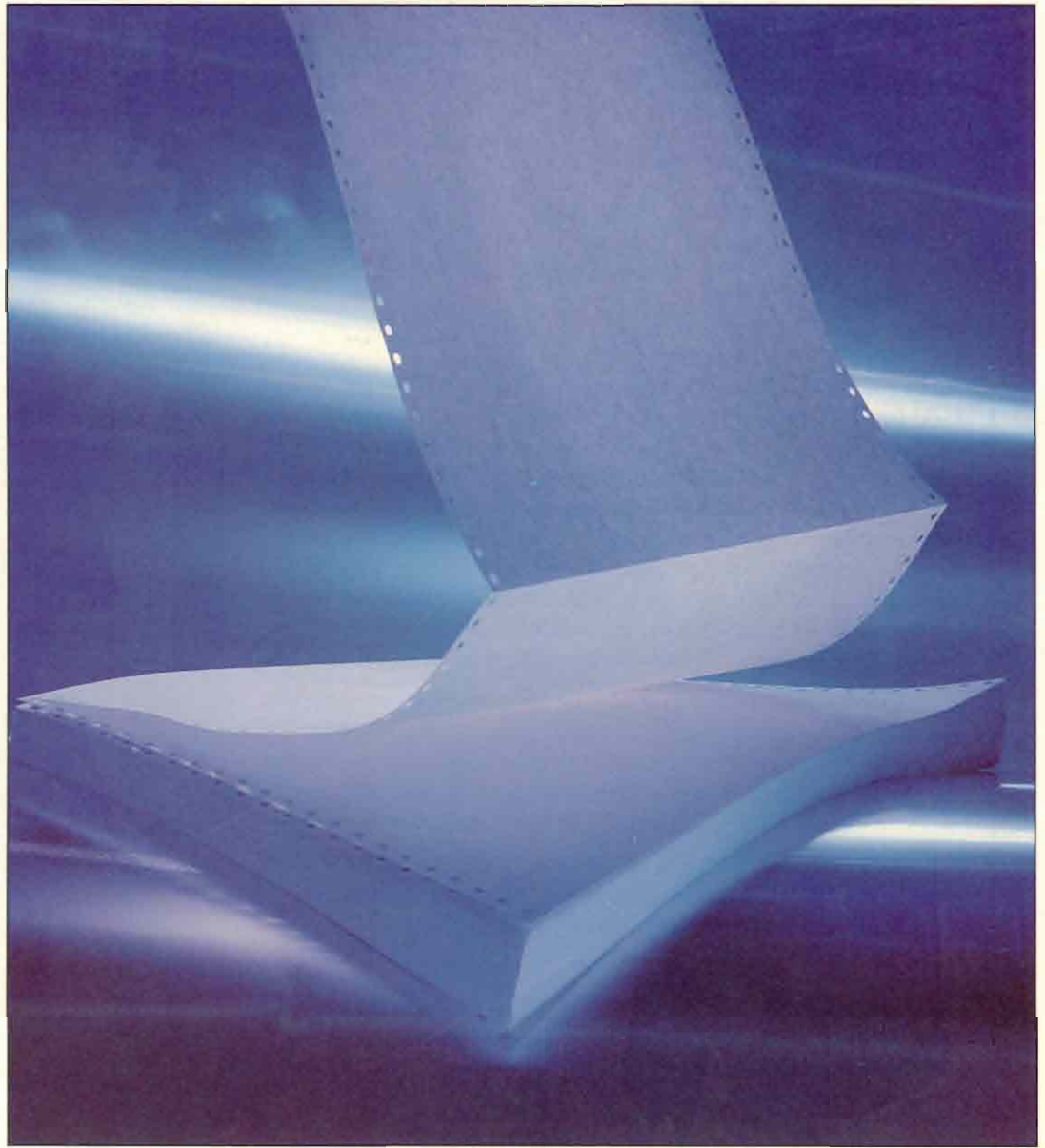

With PDQ for QUIZ from Tynlabs, you get the best of both worlds: Use QUIZ for efficient prototyping and development, then turbocharge your applications with PDQ for maximum performance.

QUIZ runs fast.

PDQ[®] for QUIZ[™] dramatically improves the run-time performance of reports written in QUIZ, Cognos Corporation's fourth generation programming language. PDQ compiles QUIZ reports into machine language instructions which can be executed directly by the HP 3000. While time savings vary, sites around the world report CPU time and elapsed time reductions averaging 50%, and greatly improved system response when reports are run during the day.

Compiling reports with PDQ is a simple one-time process. No changes to your existing QUIZ code are required, and the compiler is operated by simple commands just like those used with other HP 3000 compilers. Unlike the QUIZ COMPILE command, which only saves a few internal tables, compilation with PDQ produces a permanent program file which you can :RUN at any time to produce your report.

If you use QUIZ, you know there is no more efficient way to get applications up and running and out the door. But once you go into production, you need all the performance you can get. Now you can have the development advantage of QUIZ plus the execution speed of a true compiled language.

The PDQ compiler is available for all HP 3000 CPU models, and presently runs in compatibility mode on Series 900 systems. Call us to order your demo copy today.

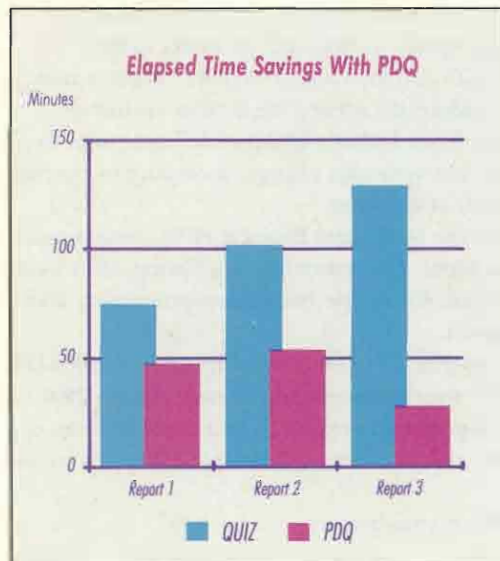

Report 1: 36% time savings.

Two-pass report with simple calculations, extensive printed output.

Report 2: 47% time savings.

Multi-pass report with moderate calculations, output in last pass only.

Report 3: 78% time savings.

Multi-pass report with extensive totals, multiple defines, and output limited to one-page summary per pass.

Tymlabs Corporation

8111 Barton Sigs, Austin, TX 78704 USA
(512) 478-0611
Fax (512) 479-0735

Tymlabs (UK) Ltd.

196 Whittington Rd, London N22 4YL, UK
01-881-6644
Fax 01-888-4087

Tymlabs-APPIC

Epinay sur Orge, France
64-54-87-37
Fax 69-34-03-23

Wick Hill Associates

Egham, Surrey, UK
0784-438441
Fax 0784-433316

Megatec Pty., Ltd.

Mitcham, Victoria, Australia
(03) 874-3633
Fax (03) 873-5667

Infosistemas Financieros

Mexico, D.F.
254-3274
Fax 254-7140

Procesaseg S.A.

Caracas, Venezuela
(582) 781-08-80
Fax (582) 781-26-10

Mandata

Krefeld, West Germany
02151-590014
Fax 02151-590073

Quant Systems

Hoofddorp, The Netherlands
2503-40334
Fax 2503-39700

Singapore Computer Systems

Singapore
775-2477
Fax 778-2747

Dark Horse Of The '90s?

Every time you turn around these days, HP is in the news. Whether the company is cutting a deal with a Japanese chipmaker, signing licensing agreements with a major player like Data General (NewWave), maneuvering its newly-acquired Apollo Division into the HP fold, or pushing industry standards, once laid-back HP is gaining the news media's attention.

An industry analyst, recently quoted in the San Francisco Examiner, said, "All of a sudden Hewlett-Packard has figured out that marketing sells products ... all the moves appear to be well thought out..." The Wall Street Journal, in an article on HP's alliance with Samsung said, HP could be a "formidable competitor" in the low-end of the RISC computer market. And, a report issued by The Sierra Group, an independent marketing research firm, concluded, Hewlett-Packard may well be the "dark horse of the 1990s" and a supplier that could emerge as a "powerhouse in distributed systems."

At INTEREX last month, HP added fuel to the fire by rolling out some 20 new products — including an eyebrow-raising Apollo workstation for under \$4,000.

Said Dean Morton, HP CEO and first vice president, "We're a new, more aggressive HP that will reduce cycle times and address the service needs of its customers."

In fact, HP's "This Is Not Your Father's Oldsmobile" campaign to alter computer users' perceptions about the company is a welcome change, according to the wide majority of attendees *HP Professional* staff spoke with at the show.

And, what is sure to keep the 3000 camp happy is HP's commitment to MPE XL. According to Wim Roclandts, vice president, Computer Systems Group, HP's long-term strategy is to "enhance" MPE XL as *the* platform for online transaction processing, and position HP-UX for the "general purpose" environment.

Welcome news to the 3,000-plus user group members who attended HP's 50th Anniversary celebration. Coupled with HP's announcement of the new Apollo 2500 workstation and HP 3000 Series 960 (another upgrade is promised next year), you could sense an optimistic beat, a rekindled enthusiasm from both users and vendors—a beat that HP plans to sound well into the next decade.

Dark horse of the '90s? Place your bets.



HOW TO GET EVERYTHING OUT OF A SPECTRUM THAT HP PUTS IN.

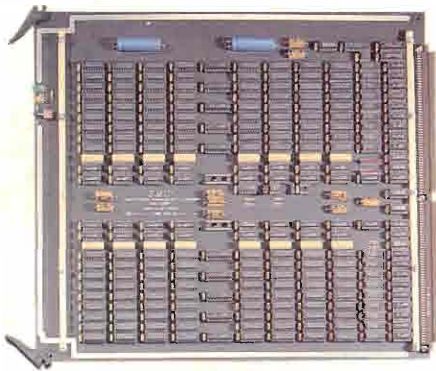
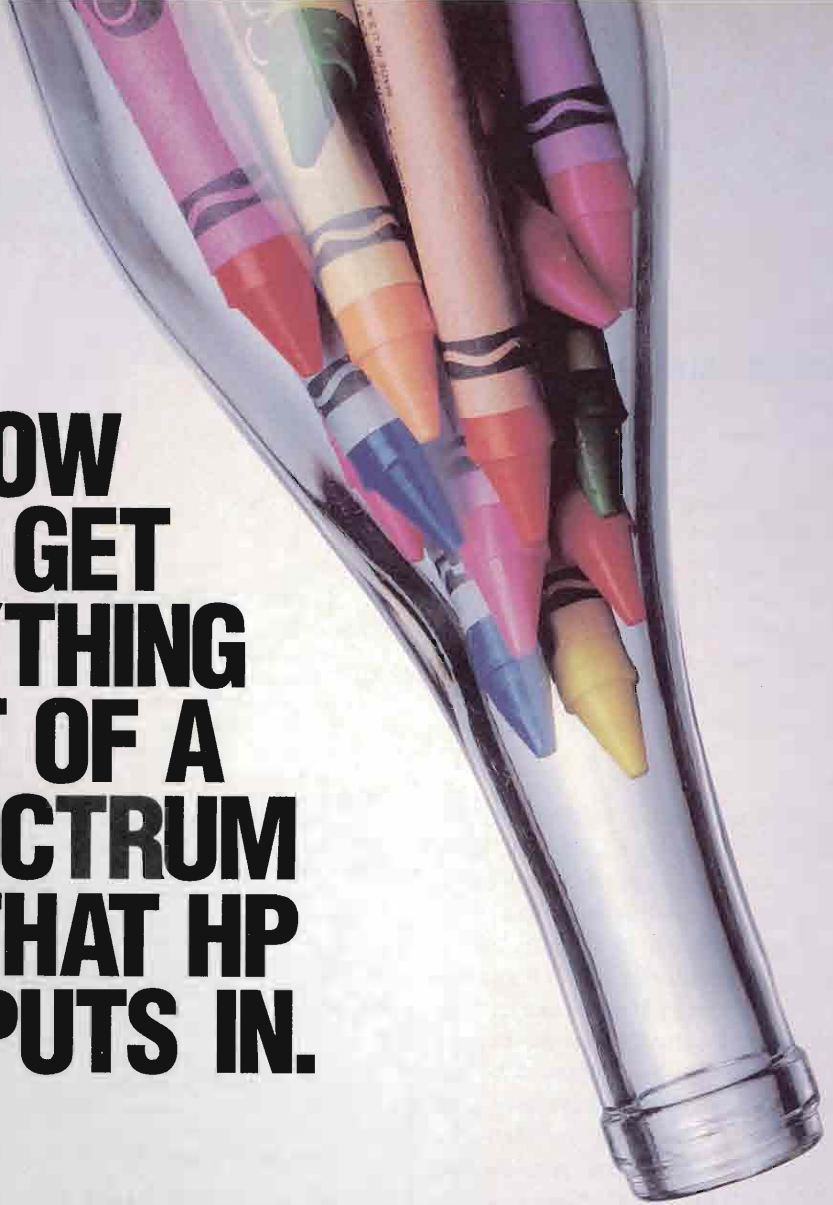

EMC's 95X Spectrum Memory for
HP 3000 950/955 Systems.

You saw terrific potential in your Spectrum system when you bought it. The trouble is, to turn that potential into productivity, you need more memory — and the cost of that can add up in a hurry. But today more and more companies are finding out that it doesn't have to.

WHAT'S GOTTEN INTO THE WORLD'S MOST SOPHISTICATED SPECTRUM USERS?

EMC's 95X memory for HP Precision Architecture systems. As the established leader in the HP 3000 marketplace, our commitment to bringing users cost-effective alternatives for memory and disc needs is unsurpassed. We continue this tradition with 95X memory for Spectrum Series systems — available in 16 megabyte capacity boards and backed by EMC's stringent testing procedures and industry-first Lifetime Warranty.

EMC also offers you the depth of support you'd expect from a leader.

Our service centers worldwide keep full spares inventories and have trained Customer Engineers on-call. And, our new full service Response Center gives you the benefits of technical expertise and dial-in diagnostic capabilities 24 hours a day, 365 days a year.

Priced significantly less than any comparable offerings from Hewlett-Packard, 95X Spectrum memory from EMC gives you everything you're looking for. A full Spectrum of performance and value.

For more information, call

**1-800-222-EMC2
(MA residents call
1-508-435-1000)**

Ext. H938.

**In Canada, call
1-800-543-4782**

EMC²

**The System
Enhancement Company.**

*HP is a registered
trademark of
Hewlett-Packard.

PRINTER DRIVER WANTED**QUERY:**

Tom Jacomet (SIG 27/MESS 2): I need a printer driver for HP's LaserJet IID printer. HP doesn't have one for use as a remote printer on the 3000. I use HP's generic printer driver file TTPCL18, which doesn't use status check, i.e., if the printer encounters an error such as paper out, the system doesn't know it, and you lose the print job. Any assistance would be appreciated!

REPLY:

Doug Shelton (SIG 27/MESS 3): I've heard that HP has omitted the ESC status request sequence from the LaserJet IID's command set. If this is the case, you won't be able to have the HP 3000 do any software status checking. I know that the LaserJet Series II and LaserJet 2000 both respond correctly, but the LaserJet 2000 requires that the Robust XON feature be enabled. One alternative is to connect the printer to an ADCC or modem ATP port and configure the port as TYPE 32 SUBTYPE 15. This causes the system to monitor the RS232 status leads and stop the spooler if certain pins aren't held high. Although you don't get complete status checks, you keep your printouts from becoming a pile of bits on the floor if the printer is powered off or its cable disconnected. Another alternative is to get a copy of HP's Workstation Configurator program. This program, free from HP, allows you to customize your own termtype files.

SLAVE PRINTER PROBLEM**QUERY:**

Carole Cotter (SIG 41/MESS 7): I've been having a unique problem with our on-line pharmacy dispensing process. The application dispenses new and refilled prescriptions. Attached to the terminals

How To Use ARIS/BB

Subscribers to *HP PROFESSIONAL* can call up our online bulletin board and log into ARIS/BB, our Automated Reader Information Service. In ARIS/BB, you can download programs from this publication, communicate with our editors, request a change of address, find additional information about advertisers, order books and back issues, check the guidelines for submitting articles, take a peek at our editorial calendar for the year and communicate with other HP users.

To log in, you'll need your subscription number from your mailing label. Set your terminal to seven data bits, one stop bit and space parity, or eight data bits, one stop bit and no parity. Set your terminal emulation to VT100 and dial:

(215) 957-1000 - Pennsylvania
(818) 577-9100 - Southern California
(415) 873-2135 - Northern California
(617) 863-5010 - Massachusetts
Baud rates: 300, 1,200 or 2,400.

After the CONNECT hit return two or three times.

The ARIS/BB symbol appears at the beginning of each program that's downloadable. Use these recommendations at your own risk. Professional Press is not liable for any damages to your system that might be caused by the hardware, software, programs or procedures discussed here.

XMODEM and KERMIT are available.

SIG Identification

The SIG categories referenced in this month's ARISTALK are:

26 Communications/Networking
27 Laser Printers/Font Cartridges
41 Applications

is a slave printer that prints out the labels for the prescription bottles. Each line gets printed through a series of escape sequences that are sent to the printer by the program. Once the label is printed the screen displays a KB LOCK on the bottom of the screen. It stays this way until

the pharmacist does a terminal reset. I've read that in this instance the transfer of data is initiated by a handshake with the terminal. The terminal responds by sending a status code (e.g., s=successful, f=failure and u=data transfer was interrupted) after each line is printed, indicating transfer completion. To correct the problem, I added logic to check the status return code after each line is printed. using a COBOL Accept Statement (e.g., Accept status-code). Just acknowledging the presence of the status code has alleviated the problem a great deal. On occasion a KB LOCK still is encountered, followed by the message, "Terminal Status Request Failed." We use a Series 950 through a communications network and HP series 700/xx terminals. Any suggestions on why this is still happening?

REPLY:

Doug Shelton (SIG 41/MESS 9): I'm not exactly sure, but I suspect the terminal is waiting for the host program to read its status. Because you originally weren't checking for status at all, the requests were building up in the terminal without being transmitted. I'm assuming you're using the escape sequence that transfers data to the printer one line at a time. This requires a status request after each line. It's possible your terminal isn't receiving the last status request. Maybe your communications network is eating it. If it's an X.25 network, check the packet forwarding parameters at the host end of the link. As an alternative, try activating record mode checking status, and send the entire label. Then you can deactivate record mode, and check status again. The terminal keyboard locks at the beginning of record mode and unlocks at the end. I haven't had a great deal of experience with 950s, so take my suggestions with a grain of salt. ■

Transforming your HP 3000 data with speed is elementary.

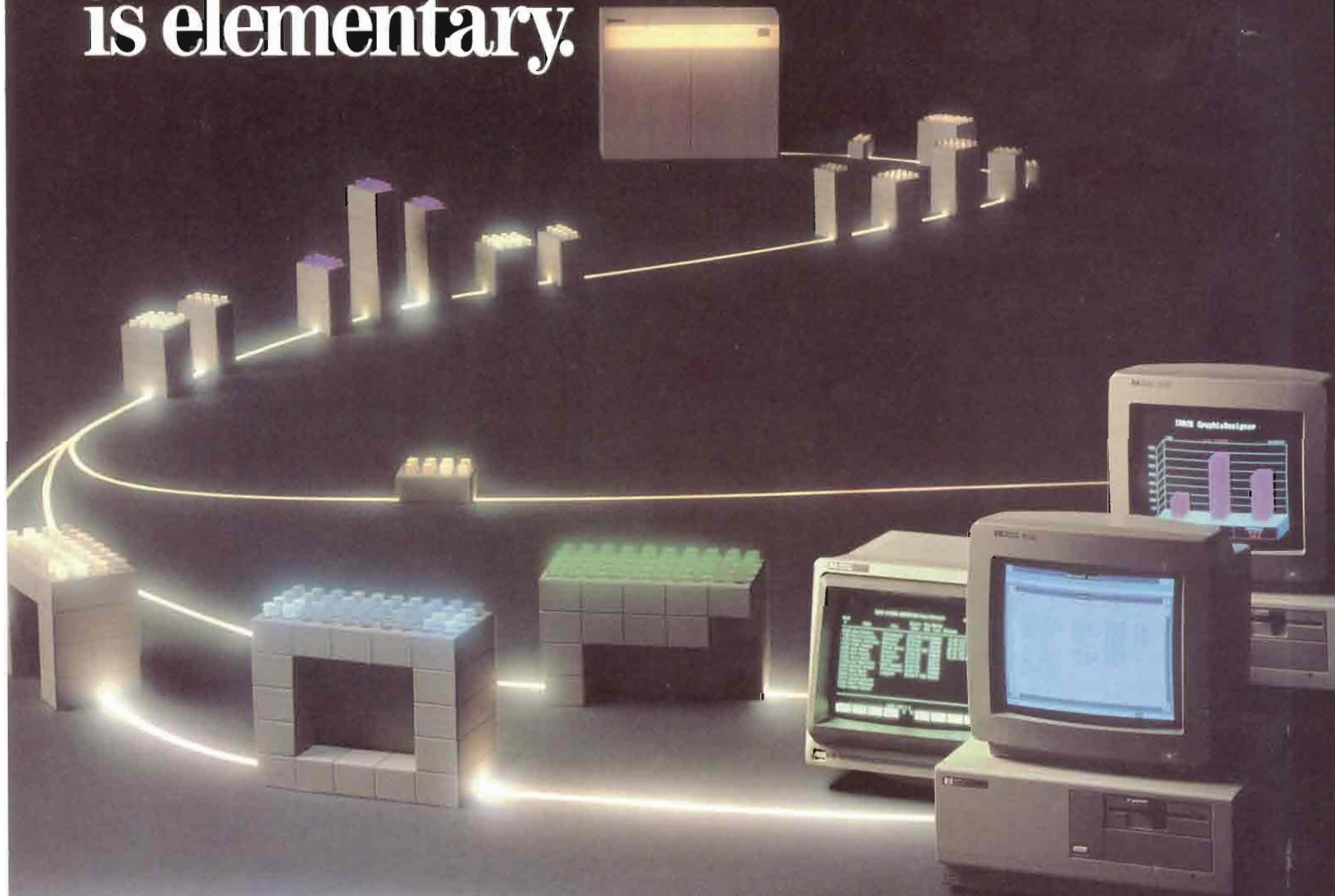

Allow your end user the speed and versatility of a complete information access tool. **DataExpressSeries™** provides MIS security and control, while extending to your end user new levels of self reliance and productivity. It's designed to ignite powerful solutions to all your HP 3000 data interchange needs. It's an easy system to learn. And it's easy to use.

As your link to HP 3000 data, **DataExpressSeries** accesses **IMAGE**, **KSAM**, **MPE** and **SD** files, downloading to PC applications such as spreadsheet, word processing and database. **DataExpressSeries** is designed to complement all major PC software, including Lotus 1-2-3, Excel, and Word Perfect to name a few. The **ReportDesigner** module has been engineered so that your end users can create sophisticated, customized reports. And your staff can generate full-color, two and three-dimensional graphics with the **GraphicDesigner** module.

With **DataExpressSeries** modules, you have a powerful information center that works with your environment. Our **Interfaces** allow you to take advantage of your investment in **PowerHouse**, **HP Dictionary**, **RELATE**, and **Omnidex**.

Call us today! Let's have a conversation for action, for service and for productivity. **800-87-IMACS**. We TAKE data seriously.

CIRCLE 118 ON READER CARD

IMACS®

IMACS SYSTEMS CORPORATION
2825 Eastlake Avenue East, Suite 107
Seattle, Washington 98102
(206) 322-7700

INTERNATIONAL DISTRIBUTION

LONDON: IMX INTERNATIONAL
London, England (01) 541-0242 Telex: 51-944017
ROTTERDAM: The Netherlands (010) 483-1126

CANADIAN DISTRIBUTION

1-800-267-9377



INDUSTRY WATCH

Peggy King

Why HP Is Choosing Partners

HP announced its alliance with Hitachi in July, revealed cooperative agreements with Samsung in August, and has hinted that we can expect more to come. What's going on?

My first reaction is to attribute the move to intensified competition with Sun and other RISC vendors. Fujitsu began making SPARC chips for Sun more than two years ago and recently became the foundry for Intergraph's Clipper. NEC became a semiconductor partner of MIPS Computer Systems in February, and in May, Toshiba and Sun announced an agreement that would allow Toshiba to manufacture SPARC chips for its own workstations. Do these partnerships mean HP is simply playing follow the leader by picking two Pacific Rim electronic giants for cooperative ventures?

According to Laura Cory, group marketing manager for the Computer Systems Group, HP considered teaming up with Hitachi more for its semiconductor process technologies than for market penetration. Unlike Sun or MIPS, HP didn't need to capture market share to get its RISC platform accepted. One important difference between HP and its competition is that HP also has a proprietary operating system that runs on RISC. The market share for MPE XL systems doesn't depend on HP's licensing agreements. Having had a proprietary operating system for nearly 15 years gives HP a solid core of customers who either have or will migrate to its HP 3000 RISC-based architecture. The HP 9000 series is also a mature product line, and many software vendors already have ported their applications to the RISC-based Series 800.

By contrast, gaining market share is a foremost consideration for Sun and MIPS. These companies stand to benefit from

having clonemakers use their chips, but HP has more to lose than to gain from the creation of clones. If it allows other companies to manufacture and sell HP-PA-based systems, these partners must be carefully chosen. HP's reputation for well-engineered, reliable products is at stake.

According to Carolyn Layne, marketing program manager for HP's Computer Products Group, HP's move to license HP-PA is a move that sets a performance standard rather than one that presents the industry with yet another contender for the industry-standard RISC chip.

Aside from gaining market share, there are other good reasons for HP to select

technology partners these days.

- Learn new semiconductor processes.
- Gain suppliers.
- Penetrate strategic geographic markets.
- Bring competitive low-end and high-end systems to the market quickly and inexpensively.

New Semiconductor Processes

To date, HP has made all of its own System Processing Unit chip sets for HP-PA systems. In addition to production facilities at its labs, HP has foundries in five U.S. cities and a packaging facility in Singapore. At these fabrication facilities,

Continued on page 84.

FIGURE				
Chip Vendor	Systems Vendor	Types (s) Of Process Technology	Location of Foundry	Shipping?
Bipolar Integrated Technologies	Sun	ECL	US US	yes
Cypress	Sun	CMOS	US	yes
Fujitsu	Sun	CMOS, (new process)	Japan	yes
Hitachi	HP	BICMOS	Japan	projected 1992
Integrated Device Technologies	MIPS	CMOS	US	yes
LSI Logic	MIPS Sun	CMOS	For MIPS, Japan and US; for Sun, US	yes (MIPS and Sun)
NEC	MIPS	CMOS, ECL (Future)	Japan and Europe	projected fall '89
Performance Semiconductor	MIPS	CMOS	US	yes
Philips	Sun	CMOS, BICMOS	Europe	no
Samsung	HP	CMOS	Korea	no
Siemens	MIPS	CMOS	Europe	projected fall '89
Texas Instruments	Sun	CMOS	US	yes

When you think of memory, think of



MEGAMEMORIES™

Pile up your savings!

Nobody stacks up to HP when it comes to computers, and nobody stacks up to MARTINSOUND when it comes to memory for HP.

Buy your HP with the minimum memory complement, and buy your memory cards from us. Whether it's your first HP, your one-hundredth, or a system up-grade, the best buy in computers is HP and the best and most affordable memory is from MARTINSOUND. No one has more memory products and nobody can beat our prices.

SERIES 9000 (216, 217, 220, 226, 236, 237, 310 and 320)

- MS-310 1 Mb — The affordable alternative to the HP 1Mb board.
- MS-320 2 Mb — Twice the memory for less than the cost of a HP 1 Mb board!
- MS-340 4 Mb — The industry's best Mb-per-dollar value.
- MS-380 8 Mb — The ultimate slot-saver!

Model 350/370

- MS-3700-8 8 Mb — 98258C MEMORY UP-GRADE

LANGUAGE CO-PROCESSOR (VIPER) PRODUCTS

- MS-83205-1 — 1 Mb stuffed
- MS-83205-2 — 2 Mb stuffed
- MS-83205-3 — 3 Mb stuffed
- MS-83205-5 — 5 Mb stuffed
- MS-83205-7 — 7 Mb stuffed
- MS-83203 — RAM expander kit, ½ Mb memory chips
- MS-TCSI — 1.0 Serial Card

HP 330, 340 and 360 Memory Boards

- MS-360-4
 - MS-360-8
 - MS-360-12
 - MS-344-4
 - MS-332-1
 - MS-332-4
- Configure your HP360 with 8, 12 or 16 Mb of RAM memory!
 "Daughter" Cards configure your HP340 with 8, 12 or 16 Mb!
 1 and 4 Mb cards for your HP332.

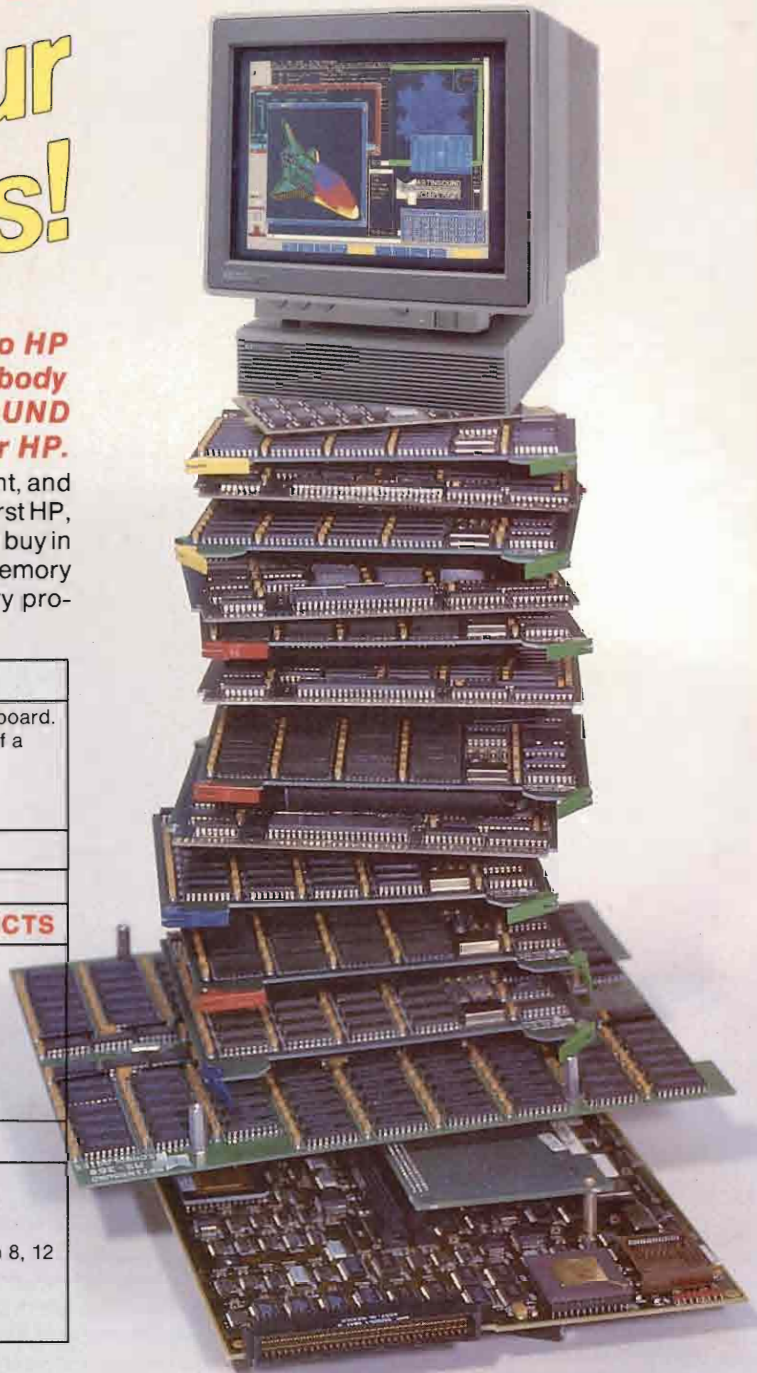

QUALITY YOU CAN TRUST!

Each board is inspected, and dynamically tested during burn-in (200 hours). MARTINSOUND backs what it builds with a full two-year warranty, 90-day money-back guarantee, and 24-hour service, if ever needed.

See your **MARTINSOUND TECHNOLOGIES** dealer, or —
CALL US TODAY (818) 281-3555

"American Built Quality and Service Since 1971"



MARTINSOUND TECHNOLOGIES • 1151 W. Valley Blvd., Alhambra, CA 91803-2493 • Phone: (818) 281-3555 • Fax: (818) 284-3092

CIRCLE 126 ON READER CARD

© 1989 MARTINSOUND INC. HP, Hewlett Packard, and Series 9000 are trademarks of Hewlett Packard, Inc.

Compete.

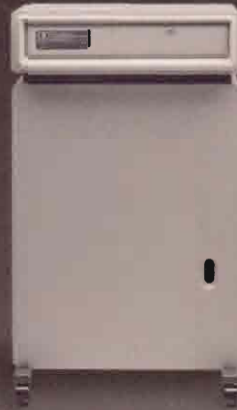

Your HP 3000 system has helped you achieve success for your company. With it, you've survived in a competitive marketplace. But now you need to meet the challenges of the future. And with an upgrade to an HP 3000 Precision Architecture system you can do just that.

From aerospace to electronics, education to healthcare, Hewlett-Packard has helped many organizations build for tomorrow. Here are just two success stories.

"With the new system from Hewlett-Packard, we're able to develop new products faster. And that's an important part of our marketing requirement. To come out with new products sooner than your competition gives you the leading edge."

— Don Sewcalk, Corporate Controller, Spalding Sports Worldwide

Sporting goods manufacturer Spalding had been using both a Series 70 system and a Series 58 system from HP. But as the company

experienced double-digit annual growth, large-scale data processing began to take longer and longer. The result? A bottleneck that kept end-users from accessing the system.

Spalding responded by upgrading to an HP 3000 Precision Architecture system. The migration was achieved with minimal retraining and disruption. Today, monthly batch-processing time has been reduced by more than two-thirds.

Dominate.

 HEWLETT
PACKARD 3000
PRECISION ARCHITECTURE

"Our products were rapidly getting more complex. We needed another performance boost. The new HP-Precision Architecture system provided us with a new foundation for growth."

-Terry Reffner, Information Systems Specialist,
General Electric Drives Department

At General Electric's Drives Department in Erie, PA, business was good. So good that computing capabilities couldn't keep up with computing demands. The solution was a Hewlett-Packard 3000 Series 950.

The conversion was fast and the migration smooth. Since then, productivity has increased steadily. And batch-processing time has been cut in half. General Electric is confident that these results can be sustained well into the future.

HP 3000 Precision Architecture systems help businesses meet critical goals better than ever. Based on Hewlett-Packard's enhanced version of RISC, they provide timely information, increase productivity, cut computing costs, and lay the foundation for future growth.

If you want to insure your leadership position, upgrade to an HP 3000 Precision Architecture system. Call us today at **1-800-752-0900, Ext. 234D**. And we'll send you a free HP 3000 Upgrade Advantage Kit.

There is a better way.



**HEWLETT
PACKARD**

CIRCLE 190 ON READER CARD

CAD Framework Initiative Forms Committees And Adds Membership

HP Is An Active Participant In Committees

When the CAD Framework Initiative (CFI) was formed from a coalition of Electronic Design Automation (EDA) software vendors, computer vendors and EDA customers at the 1988 Design Automation Conference, HP fit all three of the membership categories.

Sam Lee, of HP's Colorado Springs Division, has been a representative on the board from the onset. Currently the board of directors also includes representatives from EDA vendors Cadence, Mentor and Valid; platform vendors Honeywell and Sun, and EDA customers Motorola, Siemens and MCC. IBM joined the other major U.S. and European computer vendors when it joined CFI this August. Notably missing from CFI's membership rolls are some of the large Japanese electronics companies, only Sony, Fujitsu and Toshiba have joined.

Currently CFI has seven technical committees includ-

ing the Systems Environments committee, chaired by an HP representative. Other committees include Design Methodology Management, Data Management, Design Representation, User Interface, Intertool Communication and Architecture. HP is an active

participant on all of these committees except for Intertool Communication and User Interface.

CFI was formed to promote the development of standards for design automation software and to provide a working environment for the Computer Assisted Engineering (CAE) industry. It addresses the issues of tool integration, portability of software products to new platforms and the management of data between CAE tools.

HP And Hitachi Will Develop High-Speed RISC Chip Set

HP-PA Licensed By HP For First Time

Hewlett-Packard and Hitachi Ltd. announced that they will jointly develop a new, higher-speed chip set based on HP's RISC (reduced-instruction-set-computing) technology and Hitachi's advanced semiconductor and circuit-design technology.

As part of the agreement, Hitachi will adopt HP's RISC-based Precision Architecture (HP-PA). This is the first time since HP entered the RISC market in 1986 that it has licensed its HP-PA technology to another company.

Both companies plan to manufacture the new chip set for use in high-performance RISC-based computer systems, which they will market independently under their own brand names. The companies also plan to equip the new systems with software meeting Open Software Foundation (OSF) specifications.

Vendors who sell "point tools software," products for specific steps in the design process, need standards so that porting their product to various workstation platforms can be accomplished without major commitments of time and money. Adherence to standards is also a way that point tool vendors can be assured that their products can be integrated within design frameworks under development from the major EDA vendors.

Customers need standards so they can integrate tools from various vendors and be able to operate in multivendor environments. A "turnkey" solution from any one vendor no longer fit the needs of semiconductor manufacturers who are producing customized VLSI (very large scale integration) chips.

According to Bob Carver who represents Cadence Design on the CFI's board of directors, the eventual goal of CFI is to evolve the framework standards to the point where an EDA framework becomes an extension of the operating system the way that file management systems have during the past decade. — *Peggy King, West Coast Editor.*

TRAX/COBOL Debugger

The Source Level Debugger from CCS

Now you can debug COBOL on your HP3000 at the source level instead of at the machine language level. TRAX provides single-step operation, data display and modification, three kinds of breakpoints, simultaneous source display, and multiple windows. It enables you to debug VPLUS applications using only one terminal, and...

native mode TRAX is now available on MPE XL!

CIRCLE 241 ON READER CARD

YES! I want to know more about TRAX, and how to get a FREE 30-day copy for my: MPE V MPE XL

Name _____

Company _____

Address _____

City/State _____

Country/Zip _____

Phone: _____ Fax: _____

Clip and
mail to:



CORPORATE COMPUTER SYSTEMS, INC.
33 West Main Street, Holmdel, NJ 07733 USA
•Phone: (201) 946-3800 • Fax: (201) 946-7167•

Wavefront Enhances And Renames High-End Animation Package

Features Menu-Driven User Interface That Works With Windowing Environment

When Wavefront Technologies (Santa Barbara, CA) announced a low-end Personal Visualizer product, currently available only with Silicon Graphics workstations, the animation software company also announced enhancements and a new name for its high-end product that runs on HP's workstations with TurboSRX graphics subsystems. Dynamic Imaging System/MPIM software now is called The Advanced Visualizer, Release 2.9.

The product has four modules: Model, PreView, Image and Medit. A feature of the release is a menu-driven user interface that works within a windowing environment. The user interface is interactive and allows you to choose to work recursively among the modules of the Visualizer software, whereas the previous interface required a linear progression through

modules.

Another new feature is the addition of soft-bodied animation. This capability, also known as object metamorphosis, allows you to create animations that show stretched, bent and distorted objects. It allows object re-entering to be done on the fly without writing custom programs.

The ability to change objects on the fly is especially useful to mechanical analysts and designers if they are able to import data directly to the computer-aided design (CAD) database they are using. For that reason, Wavefront also has provided translators for several popular CAD packages.

Advanced Visualizer 2.9 is available this fall for between \$29,000 and \$55,000 depending on the hardware platform. — Peggy King, West Coast Editor

DEC And Apollo Extend Remote Procedure Call Specification

RPC Offers Enhanced Interoperability And Distributed Applications Capabilities

Digital Equipment Corp. (DEC) and Hewlett-Packard's Apollo Division released further details regarding the status of their joint development effort to extend the remote procedure call (RPC) component of Apollo's Network Computing System

(NCS) to support a broader array of applications and services.

In February 1989, the companies announced they were working together to extend the RPC and said they would integrate the resulting remote procedure call capability into their products and

offer an open remote procedure call specification to appropriate standard bodies to promote standardization in the design and implementation of distributed applications.

Currently, the NCS remote procedure call technology allows pieces of software applications to run simultaneously in a LAN environment on a variety of processors and hardware platforms. This allows the applications to take optimum advantage of the

network's specialized resources and complete tasks more quickly and efficiently.

The Joint specification will extend the RPC's capability in the areas of wide area networking, large data processing applications, international languages and additional network platforms and protocols. It will be made public coincident with the Open Software Foundation's (OSF) request for remote procedure call technology submissions.



The HP 700/32 display terminal is for system users who require ANSI and DEC VT320 compatibility.

HP Expands Display-Terminal Family

Suits UNIX System Environment And General-Purpose Applications

Hewlett-Packard introduced a display terminal for system users who require ANSI and DEC VT320 compatibility. The new terminal has four times the display memory and user-definable keys offered by the competing terminal from DEC.

Ideal for UNIX system environments and general-purpose applications, the new HP 700/32 complements HP's terminal line by providing compatibility with the ANSI standard, as well as enhanced functionality and ergonomics. It's U.S. list price is at \$575.

The HP 700/32 display terminal is plug compatible with the DEC VT320, and works with applications that are designed for the DEC VT220, VT100 and VT52 terminals and other applications that follow the ANSI X3.64 protocol.



MAESTRO Squeezes Every Drop of Throughput From Your Batch Job Processing

Getting the most out of your batch processing while continuing to do it manually can be like squeezing water from a stone. But with MAESTRO's automated approach you'll increase your batch job throughput by an average of 35-50%.

MAESTRO allows you to realize your full production potential because it reacts instantly to a job completion, reply to a prompt, job termination, or any other significant event. This split-second response is impossible for even the most diligent operators, because they're often busy with other things like loading paper. MAESTRO's attention to detail also minimizes costly errors.

MAESTRO automatically manages a variety of tasks which are usually performed manually, such as integrating user job requests, scheduling production, preparing job streams, and documenting job status. In fact, MAESTRO is

so efficient it gives you the potential to run production completely unattended. Even if you have multiple CPU's.

We could go on and on. About saving computer time. Ease of use. Cutting personnel costs. And much more.

But all it takes is one look at MAESTRO in action. Call us today at (415) 968-7511 for a 30-day demonstration or to find out more.

"For a permanent solution, it's Unison."

Unison
The data center management company
SOFTWARE

415 Clyde Avenue
Mountain View, CA 94043
(415) 968-7511

In the UK:
01-879-3797
Telex: 928536

CIRCLE 141 ON READER CARD

More Support For HP NewWave Systems Interface, Glockenspiel And Tymlabs Support Software Application Environment

Hewlett-Packard announced Systems Interface Inc. (Canada), Glockenspiel Ltd. (Ireland) and Tymlabs (Austin, TX) are developing products to use the HP NewWave environment.

HP NewWave is a software applications environment that makes it easier for users to move smoothly among several application programs and create documents made from different types of data. It also includes "agents" that automate routine or complex tasks, and an object-management facility that automatically updates related files from different applications.

Systems Interface will implement its Microsoft Windows/UNIX-system communications product, TransActor, under the HP NewWave environment and HP-UX.

TransActor provides soft-

ware technology for PC and UNIX system integration. Available this fall, the program provides user access to the UNIX operating system through HP NewWave.

Glockenspiel's CommonView, published by Image Soft Inc., is a C++ compiler and class library that simplifies the programmer's tasks of developing for the HP NewWave environment. It currently supports MS Windows and OS/2 Presentation Manager.

Tymlabs offers a Microsoft Windows-based terminal-emulation and file-transfer program for the HP NewWave environment. Business Session for Windows provides HP 2392 block-mode terminal emulation in the Microsoft Windows 2.0, Windows/286 and Windows/386 environments on HP Vectra PCs and other industry-standard PCs.

Small Firms Buying Big

Over Half Now Have Personal Computers

Over half of all small businesses in the U.S. now use personal computers, according to the results of a recent study conducted by BIS CAP International.

The national survey targeted firms with under 100 employees and found that 52.8 percent had personal computers. A year ago, PC penetration of small businesses was 46.8 percent.

The six percent increase in ownership means that 300,000 small firms obtained a PC for the first time last year.

According to BIS CAP, small businesses and home offices obtained 2.3 million of the 7.1 million personal computers sold in the U.S. last year. This share of the market will increase as more first time buyers take the plunge and as more experienced users look for additional machines.

PC Penetration In Home Offices/Small Businesses

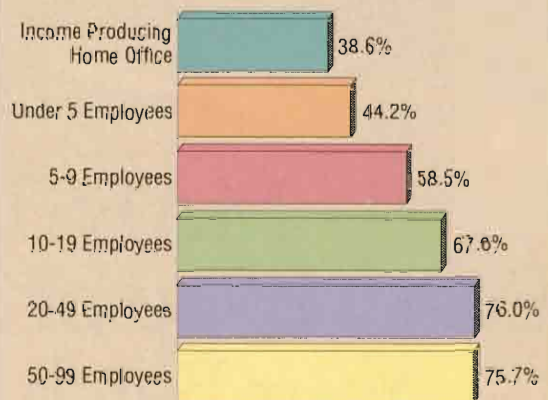

Courtesy of BIS CAP International

HP BASIC Language Processor Allows PCs To Emulate HP 9000 Series 300 Workstations

*BLP-II Offers Faster Boot Operation
And Graphics Performance*

Hewlett-Packard introduced the HP BASIC Language Processor II (BLP-II) for the HP Vectra PC, the IBM PC/AT and other MS-DOS personal computers.

The processor allows these PCs to function like HP 9000 Series 300 workstations, providing the benefits of a

superior instrument controller while giving you access to the library of PC-DOS application software.

BLP-II offers graphics performance up to 3.7 times faster than the original BLP-I product, and provides much

faster boot operation (less than 10 seconds).

BLP-II also features bidirectional communication between HP BASIC, running in the background mode and DOS applications such as Lotus 1-2-3 and HP MemoMaker, as well as DOS data files on internal hard discs.

BLP-II's bidirectional capability enables a window to appear on the screen above an application, allowing the user to issue a command to

BLP-II in the background. Through this pop-up window, you can communicate with HP BASIC without disturbing a PC application that's running simultaneously. As data is acquired by HP BASIC, it can be transferred immediately to the active DOS application, or from a DOS application to background HP BASIC programs.

HP Deskmanager users . . .

Are You Still Chiseling Your Text in HP Slate?

Workarea > list

Item	Subject	Type	Created
1	Memo to Accounting	Package	01/27/89
2	Letter to Sales Reps	HPSlate	05/02/89

Workarea > CREATE HPSLATE
Subject: New text editor Desk

To: Mr. MIS Director

From: Secretary to the President

Ref: A better way of editing text in HP Deskmanager

The president would like to know why we have this fancy computer system and have this archaic text editor. Cave men had it easier with hammers and rocks to carve their messages. My little PC can edit better than your big main frame. We need to be able to insert words and sentences in the middle of paragraphs, move phrases around and justify right margins.

Our productivity is really suffering from all the re-typing and fussing around to get a memo into a format. It would be of great benefit to be able to take an existing file sent to me, make changes, and send it back without having to re-type it. Think of the productivity gain!

DBS presents DeskEdit™

DeskEdit is a powerful text editor for HP Deskmanager users. Imagine what auto word wrap, cut & paste and text enhancements would be like. DeskEdit is not a add on application, DeskEdit is truly integrated into Deskmanager. DeskEdit can be used at the "Workarea >", "PACKAGE >", "MESSAGE >", and "< foldername > >" prompts. You can Create, Edit, Read, and Print text.

Features include:

- Auto Word Wrap
- Bold, Underline, Italic
- Portrait and Landscape Printing
- Use at any Terminal or PC
- Low System Overhead
- Any Printer or Font Cartridge
- Function & Control Key Editing
- Up to 10 Fonts per Page
- Decimal Tabs
- MPE & Native Mode MPE / XL

If you want to dramatically increase your productivity, call us today for a full function demo. Install DeskEdit, and in minutes enjoy the power of a PC like word processor on your HP3000.



31 Highway 12
Flemington, NJ 08822
201/782-8811

HP Deskmanager & HP Slate are Trademarks of Hewlett Packard

SALES & SUPPORT
1-800-DBS-ASSIST
ORDERS
FAX: 201-782-0247

ENTER 111 ON READER CARD

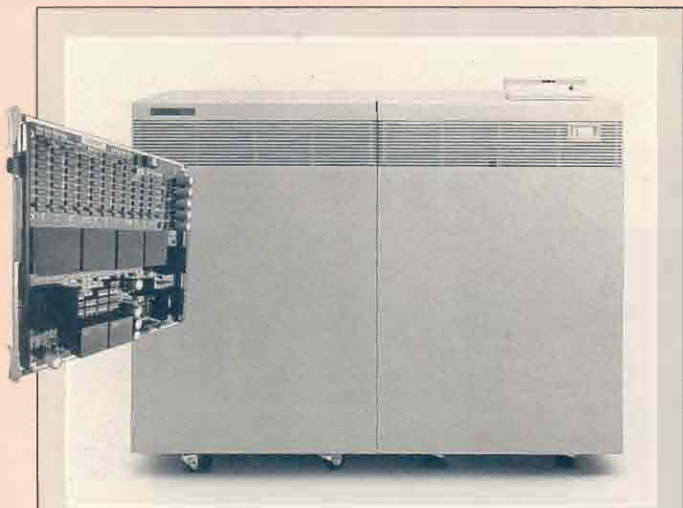

Hewlett-Packard Introduces New 3000 Model

HP Series 3000, Model 960 Improves Performance By 40 Percent

HP has introduced a new top-of-the line HP 3000 RISC-based minicomputer that accelerates HP's drive to become a leader in the online transaction-processing (OLTP) marketplace.

The HP 3000 Series 960 is tuned for high-throughput. It features an enhanced release of the HP MPE/XL operating system (V2.0) and offers performance increase of up to 40 percent over the Series 955. It's based on RISC-based HP-PA architecture.

Relative to competitive products, the Series 960's throughput rival the performance of low-end IBM mainframes. In transaction-processing applications, the Series 960 delivers more than twice the performance of an IBM AS/400 Model B70 and offers a 20 percent price/reduction advantage over the DEC VAX 6000 Model 430.

The Series 960 is \$485,000.

HP Extends Printer Family

LaserJet IIP Offers Several New Features

The newest member of the HP printer family is the four-page-per-minute HP LaserJet IIP printer. Compatible with the HP LaserJet Series II and IID printers, it employs HP's PCL printer lan-

guage, which ensures a broad base of software support. U.S. list price is \$1,495.

The printer comes with 512 KB of memory, 300 dpi printer resolution, two slots for memory upgrade boards, 14 internal fonts, one font/per-

sonality cartridge slot and a 50-sheet multipurpose input paper tray that adjusts for letter, legal, A4 and executive paper sizes as well as four sizes of envelopes.

A 20-sheet face-up output tray for labels, transparencies and envelopes and a single-

component toner cartridge, good for 3,500 pages, are shipped with each printer.

Standard memory on the printer can be expanded to 4.5 MB by adding a combination of 1- and 2-MB memory boards into the two memory-board slots.

Apollo Introduces Desktop Graphics Workstations

Hewlett-Packard Strengthens Position In Workstation Marketplace

Through its Apollo division, HP introduced a family of desktop graphics workstations and what it believes is the first full-function, high-performance workstation priced at less than \$4,000.

The Apollo Series 2500, personal workstation with an entry-level U.S. list price of \$3,990 combines high-resolution integrated graphics with 20MHz Motorola 68030

microprocessor and a 20MHz 68882 floating point coprocessor to provide 4 mips performance.

The Apollo Series 3500 and Series 4500 desktop visualization systems deliver up to 20,000 3-D smooth-shaded polygons and 300,000 3-D vectors per second. They are based on the faster 25MHz and 33MHz versions of the Motorola 68030, delivering 5 mips and 8 mips performance respectively.

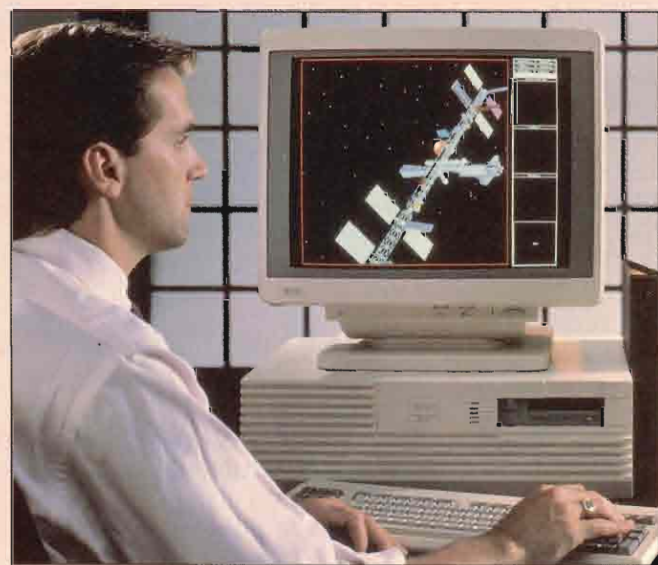

Apollo Series 4500 Desktop Visualization System



World Class Series™. Improves efficiency and productivity in your company from top to bottom.



It's a sight for sore eyes. World Class Series accounting and human resource software means your people will be able to see more of the information they need to make decisions.

Borderless Integration and Express Navigation let you move from one system to another with the stroke of a key.

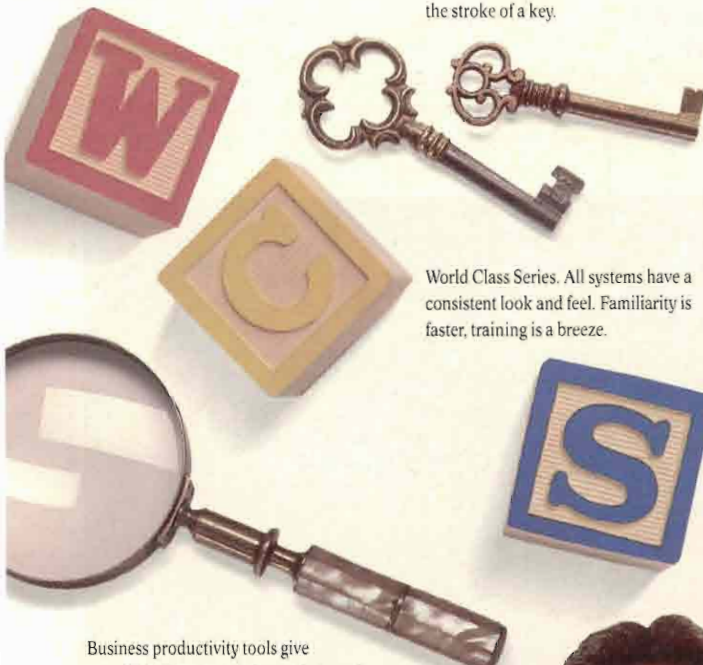

World Class Series. All systems have a consistent look and feel. Familiarity is faster, training is a breeze.

Business productivity tools give your executives a more focused view of information, without losing sight of the big picture.

Thanks to our highly trained personnel, systems can be implemented with minimal support from your MIS staff.

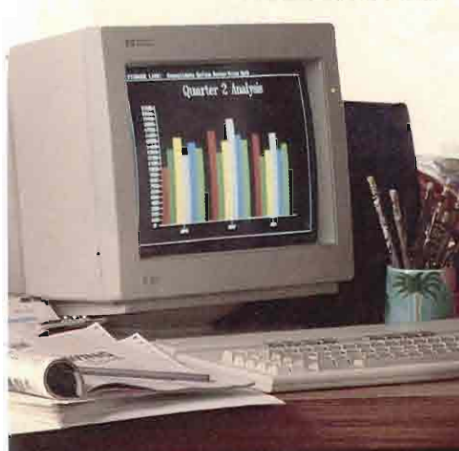

Finally, business management software designed to improve your vision.

What do you get when you marry the industry's hottest general ledger system with some of the most popular accounting and human resource software ever written for HP's Classic and Precision Architecture?

World Class Series™ from Collier-Jackson

It's a sight for sore eyes. We've clearly taken advantage of native mode and Precision Architecture. The results? Borderless integration and express navigation for all our accounting and human resource software. This gives you and your people greater accuracy and increased flexibility. Quickly.

And with such business productivity tools as the award-winning 20/20™ spreadsheet from Access Technology, executives can now get a more focused view of the information they need, without losing sight of the big picture.

Our World Class Series software is easier to use than ever. All systems have a consistent look and feel. Familiarity is faster. And training is a breeze for even the most novice user.

Best of all, Collier-Jackson's World Class Series affords you a total business solution integrating financial, accounting and human resource software. And each system is fully featured to maximize your performance.

Thanks to our highly trained application and technical specialists, the systems can be implemented by each department with minimal hand-holding from your in-house MIS staff.

If your company's management could benefit from improved vision, take a long, hard look at World Class Series software from Collier-Jackson. The differences are plain to see. Call us now at 813-872-9990.

CompuServe®
Collier-Jackson

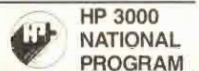

CIRCLE 164 ON READER CARD

Apollo Division Announces Agreement With Oracle

Hewlett-Packard through its Apollo Division announced a marketing agreement with Oracle Corp. and the availability of the latest release of Oracle Version 6.0 on all Apollo workstations.

Both companies will promote and market the Oracle relational database management system (RBDMS) software products.

ORACLE Version 6.0 with a transaction-processing option now is available for the first time on the Apollo Series 10000 personal supercomputers, along with the entire line of Oracle's application-development tools. Created for a wide range of demanding applications, which traditionally have required supercomputer-class performance, the Series 10000 is designed to meet the customer data-server requirements of the ORACLE database.

Simulation Software Available On HP Workstations

McDonnell Douglas and Hewlett-Packard announced that the manufacturing simulation application software, PLACE, produced by McDonnell Douglas will be ported to the HP 9000 Series 300 graphics workstations.

The manufacturing simulation application software has been used successfully over the past six years by aerospace, automotive and other manufacturing companies to design, simulate and perform offline programming of robotic manufacturing work cells in North America and Europe.

With the availability of high performance, integrated graphics workstations, the PLACE simulation software now can be made available at lower overall cost, and on a common hardware platform (the HP Series 300 workstation) with the McDonnell Douglas UNIGRAPHICS CAE/CAD/CAM applications software. The HP Series 300 SRX and TurboSRX graphics workstation provide

the performance and visual quality needed for the extensive requirements of the PLACE software.

Contact McDonnell Douglas, 325 McDonnell Blvd., Hazelwood, MO 63042; (314) 232-5287.

Circle 378 on reader card

WRQ Releases Version 3.4 Of Reflection Software

Walker Richer & Quinn has announced the new version of its Reflection terminal emulation software. The new release, designated

version 3.4, includes feature enhancements to the current Reflection.

Specifically, release 3.4 includes Application Program Interface (API) in all versions of Reflection. Reflection API is a tool that allows programmers to write DOS applications that access existing host programs. Libraries for C, Turbo PASCAL and Microsoft Quick BASIC are included in a programmer's toolkit in the PLUS versions of the products.

Through embedded API functions, DOS applications can access a full range of

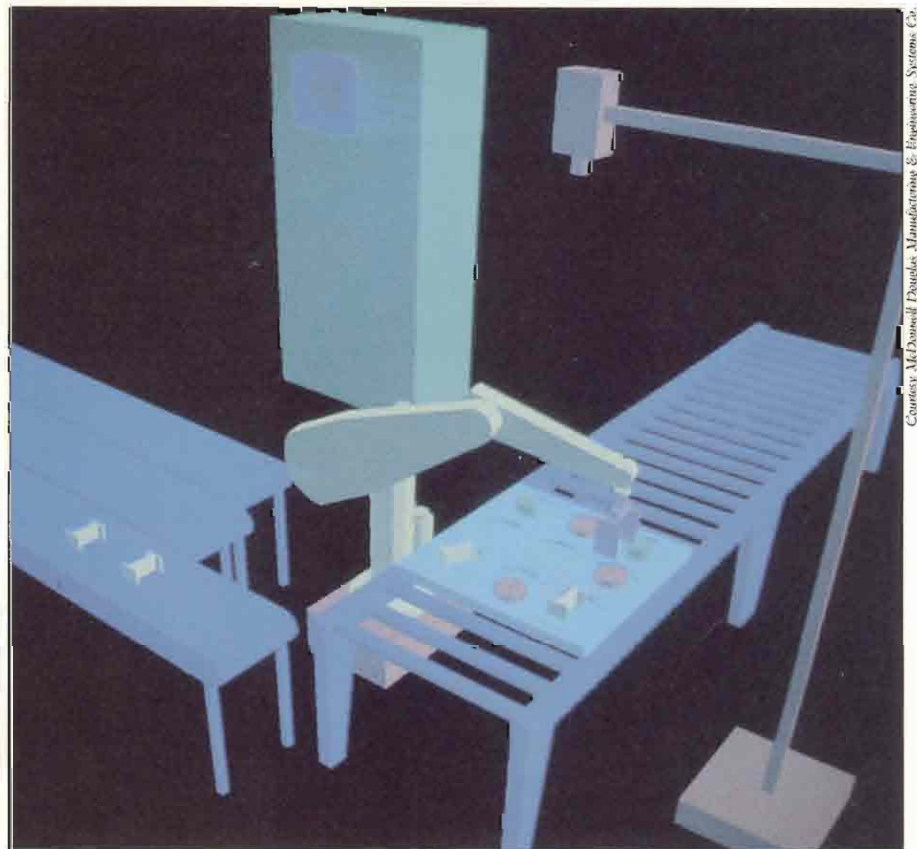

McDonnell Douglas' Simulation Software helps visualize manufacturing processes.

Courtesy: McDonnell Douglas Manufacturing & Engineering Systems Co.

Reflection features including command language and file transfer. As a result, anything that you can do manually on the terminal emulator now can be simulated through API commands such as typing on a keyboard, issuing host commands or filling in data entry screens.

Version 3.4 also provides print-to-disc capabilities within the printer set-up screen enabling users to open a PC file to accept DOS print-screens or any Reflection or host print commands. The print-screens or commands can then be held within the PC file until it's closed or printed.

Contact Walker Richer & Quinn Inc., 2825 Eastlake Ave. East, Seattle, WA 98102; (206) 324-0350.

Circle 395 on reader card

HP Extends LaserRX/MPE To RISC-Based Computer Line

Hewlett-Packard announced that HP LaserRX/MPE, a CD ROM-based performance-management tool, now runs on HP 3000 Precision Architecture (HP-PA), with the HP MPE/XL operating system.

The addition of HP MPE/XL functionality to HP LaserRX/MPE follows the August 1988 introduction of HP LaserRX for HP 3000 systems based on the HP MPE V operating system.

Through HP LaserRX/MPE, you can gather data regarding HP 3000 (HP MPE/XL and V) systems' CPU performance, memory and disc utilization, response time and transaction throughput. The tool enables the user to conduct performance-management tasks, such as identifying and isolating system bottlenecks, evaluating corrective actions and balancing system components for maximum efficiency.

Fixed Assets System Works With Bar Code Reader

Collier-Jackson, a CompuServe Software Products Division company, has developed bar code inventory compatibility for its HP 3000 fixed assets system.

This new capability quickens the process of inventory and tracking an unlimited number of fixed assets. Date and time of scanning and the tag number are stored automatically in a hand-held bar code reader. Common data entry errors such as trans-

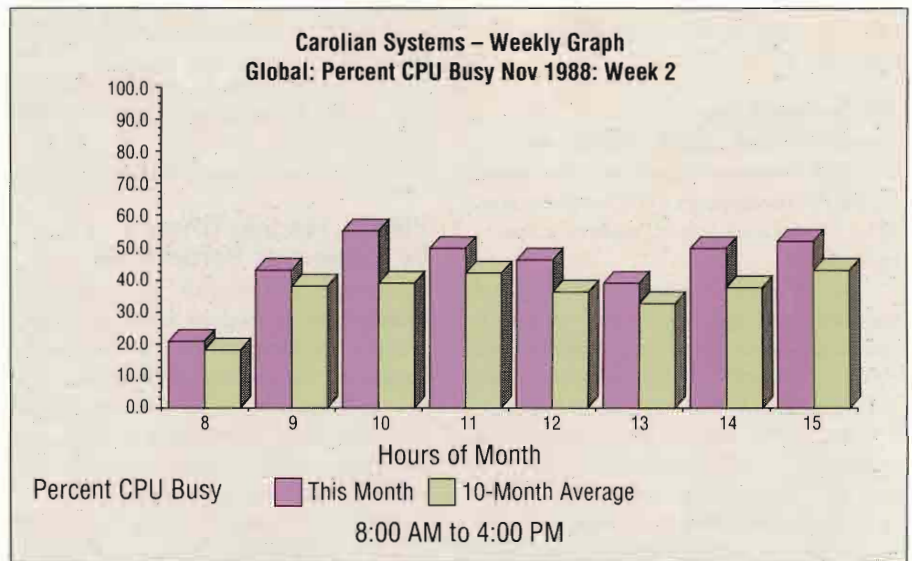

Carolian's SYSPLAN/XL provides graphic and/or written reports on global and process level CPU busy and global disc I/O.

position and duplication are eliminated. Data is transferred from the hand-held bar code reader to a PC where extensive editing and reporting are handled prior to uploading into the Collier-Jackson fixed assets system. Additional validation procedures ensure the accuracy of information within the application, and, if necessary, further editing can take place online. System reports indicate missing assets and alert users to any changes relating to existing assets, such as transfers. Company, division and department locations as well as actual physical locations (within each area) are maintained for all fixed assets along with their most recent inventory date. Contact Collier-Jackson Inc., 3707 West Cherry St., Tampa, FL 33607; (813) 872-9990.

Circle 396 on reader card

Carolian Systems Offers Performance Analysis Tool

Carolian Systems International Inc. announced the release of SYSPLAN/XL version A.01.00. With SYSPLAN/XL you can manage current system resources and forecast future needs, maximizing the productivity of your operations and enabling a greater return on your computer investment.

SYSPLAN/XL, a long-term performance analysis tool on the XL, provides both graphic

and/or written reports and gives accurate, up-to-date information on global and process level CPU busy and global disc I/O. These reports help to identify performance bottlenecks and resource usage trends so you can make informed decisions about future hardware requirements and fine-tune your system for maximum efficiency.

Special features of SYSPLAN/XL include a Collector User Interface and softkey execution ability.

Contact Carolian Systems International Inc., 3397 American Dr., #5, Mississauga, Ontario L4V 1T8; (800) 263-8787.

Circle 387 on reader card

HP Adds Entry Level Computer UNIX System

Hewlett-Packard expanded its family of HP Precision Architecture (HP-PA) systems with an entry-level, multiuser computer based on the UNIX operating system and RISC (reduced-instruction-set computing) architecture.

With a U.S. list price of \$14,900, the new HP 9000 Model 815S minicomputer provides 85 percent of the performance of the current Model 825S computer at 60 percent of the price.

A fully bundled system for 16 users is U.S. list priced at \$29,500. This includes a

300-MB disc drive, a tape-cartridge system, 18 serial ports and a 16-user license for the HP-UX operating system, which comes pre-loaded on the disc.

TK Solver Plus Available On UNIX Platforms

Universal Technical Systems Inc. (Rockford, IL) has started shipping UNIX system versions of its TK (toolkit) Solver Family of software products.

The TK Solver Plus equation solving and knowledge management software, as well as various TK applications, are now available on a number of UNIX system workstations such as IBM AIX/RT, Sun, HP-UX and Apollo.

The UNIX versions of TK Solver Plus amplify the unique features of TK. Users now will be able to take advantage of the multiuser, multitasking environment and to stretch the size and complexity of TK models beyond the constraints of PC versions of the program.

TK Solver Plus is a rule-based, declarative

language. It provides an object-oriented method of formulating and solving problems in engineering, scientific, financial and other fields.

Contact Universal Technical Systems Inc., 1220 Rock St., Rockford, IL 61101; (815) 963-2220.

Circle 393 on reader card

ViVa24 Modem Offered By Computer Peripherals

Computer Peripherals Inc. (CPI) a manufacturer of modems and enhancement products for IBM and compatible personal computers, has announced the release of its new 2400 bps external modem, the ViVa24 Modem. CPI offers two models, the ViVa24m with MNP 5 data compression and a less expensive ViVa24 without MNP 5.

This Hayes compatible modem operates in 2,400, 1,200 and 300 bps and includes auto-dial/auto answer, auto fall-back to 1,200 bps, adaptive equalization, non-volatile memory and built-in self diagnostics. The

ViVa24 supports V.21, V.22 and V.212 bis and the Bell 103 and 212 standards of the Consultative Committee on International Telephone and Telegraph (CCITT) and is compatible with IBM personal computers, IBM compatibles and Apple computers. Contact Computer Peripherals Inc., 667 Rancho Conejo Blvd., Newbury Park, CA 91320; (805) 499-5751.

Circle 394 on reader card

HP 3000 CASE Tool Supports SQL

Quality Consultants Inc. (QCI) has announced release 3.1 of ARTESSA, the integrated CASE toolset for the HP 3000 software and application development.

Application design and prototyping capabilities are extended with full SQL support using ALLBASE, HP's relational database management system on its Spectrum-class machines.

Continued on page 86.

USS Unified Software Systems

a Division of Unified Industries Incorporated

Have you made your System Secure?



Experience the new standard in

MPE SECURITY!

And Now
XL
Compatible!

Security PLUS

Call for a *free* demo tape today

Unified Software Systems
6551 Loisdale Court, Suite 400
Springfield, Virginia 22150-1854
(703) 922-9800

USS Marketing, Inc.
6555 La Jolla Boulevard, Suite 8
La Jolla, California
(619) 454-8441

CIRCLE 139 ON READER CARD

WE'RE THE WINDOWS SPECIALISTS.

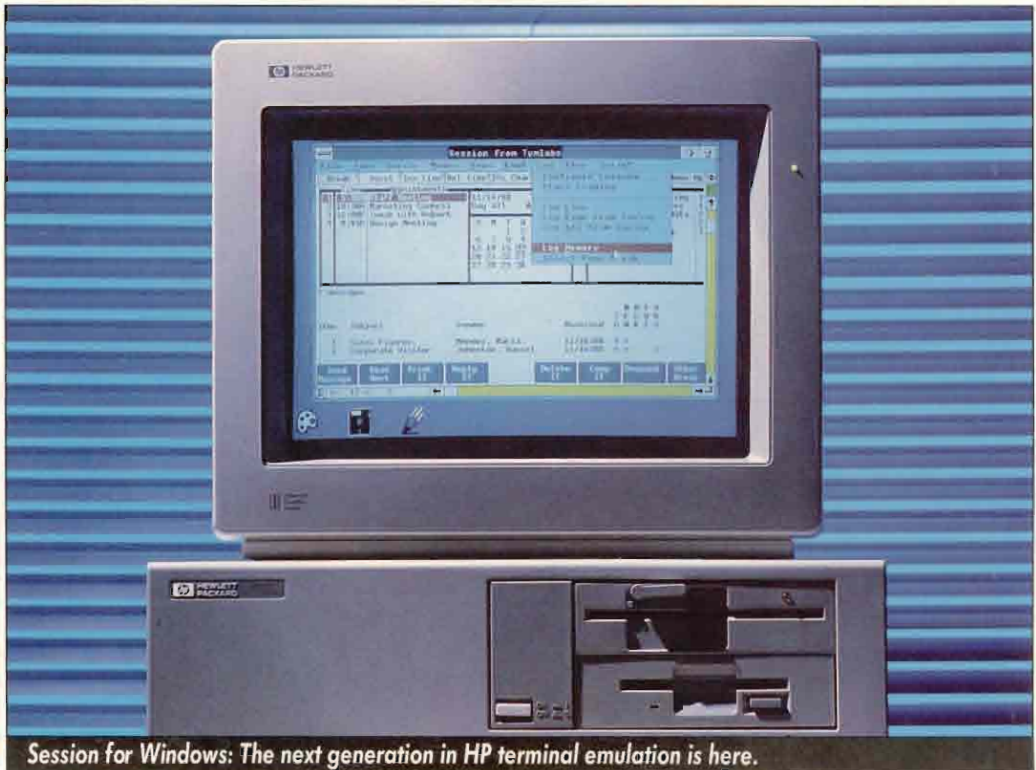

Session for Windows: The next generation in HP terminal emulation is here.

Four years ago, Tymlabs pioneered the development of Session™ for Macintosh, an HP terminal emulator for the see-and-point desktop environment. Packing a sophisticated feature set into an intuitive, enjoyable and productive user interface, our Mac products have won acclaim from users and critics alike.

Building on the foundation of Microsoft® Windows for the PC, Vectra, and compatibles, we have been able to bring the power and ingenuity of our Mac-based emulators to Windows users as well. On both Mac and PC platforms, Session makes terminal emulation a full partner with today's desktop applications. For example, you can extract data from a database on your HP host and display it on your "terminal screen" (your Session window). Using the mouse or keyboard commands, you can copy the information into your PC or Mac-based spreadsheet, perform a few calculations, then paste

the results into a memo which you send out via HPDESK. You can even run multiple concurrent sessions on the host, leaving HPDESK or a lengthy compile running in one window, while you go on to other HP-based activities in another.

If this sounds like the solution you've been waiting for, don't wait any longer. Whether your organization has PCs, Macs, or both, you can standardize on Session for all your emulation needs. And because Windows is the stepping stone to HP NewWave and OS/2 Presentation Manager, Session protects your investment in software and training as you move to these powerful new environments.

CIRCLE 165 ON READER CARD

Tymlabs Corporation • Austin, Texas USA • (512) 478-0611 • Fax (512) 479-0735
Tymlabs-APPC • Epinay sur Orge, France • 64-54-87-37 • Fax 69-34-03-23
Megatec Pty., Ltd. • Mitcham, Victoria, Australia • (03) 874-3633 • Fax (03) 873-5667
Processeg S.A. • Caracas, Venezuela • (582) 781-08-80 • Fax (582) 781-26-10
Quant Systems • Hoofddorp, The Netherlands • 2503-40334 • Fax 2503-39700

Tymlabs (UK) Ltd. • London, UK • 01-881-6644 • Fax 01-888-4087
Wick Hill Associates Ltd. • Egham, Surrey, UK • 0784-438441 • Fax 0784-433316
Infosistemas Financieros S.A. de C.V. • Mexico, D.F. • 254-3274 • Fax 254-7140
Positronika GmbH • Essen, West Germany • 0201-237116 • Fax 0201-332707
Singapore Computer Systems Pte. Ltd. • Singapore • 775-2477 • Fax 778-2747

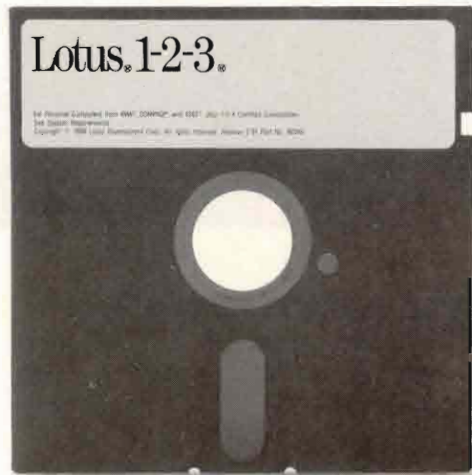

Good.



Better.

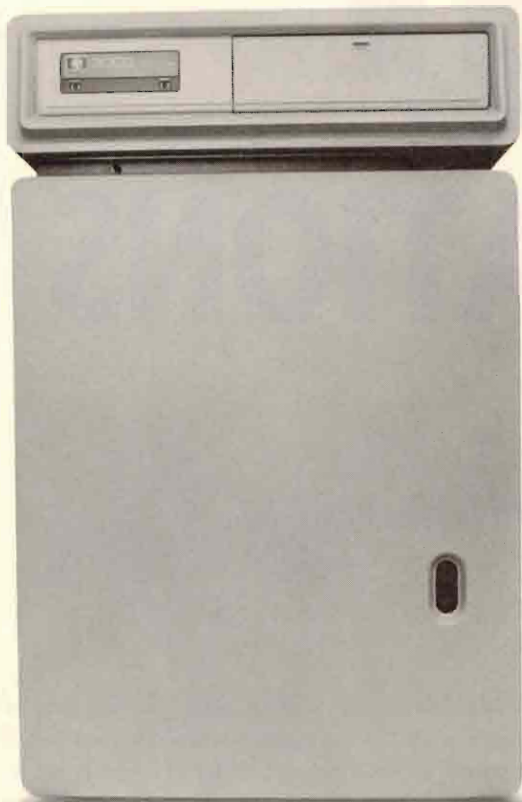

Why.

We'll be the first to admit that Lotus 1-2-3[®] is a fine piece of software.

But 1-2-3 only runs on personal computers. Whereas 20/20[™] runs on Hewlett-Packard *minicomputers*, among other platforms. (It's the *leading* spreadsheet for multi-user systems.)

The differences are significant.

Run 20/20 on your HP system, and everyone with access to the system has access to 20/20. So sharing models is simplified. And since 20/20 also runs on other minis, mainframes, even PC's, your whole organization can standardize its spreadsheet operations.

There's even more to recommend 20/20. For example, its advanced graphics are integrated with the spreadsheet itself, allowing you to display both simultaneously. Its consolidation capability enables you to consolidate multiple models. And its flexible ASCII import capabilities let you populate your spreadsheets with data from any number of sources.

One other plus: since 20/20 is 1-2-3-like in its basic command structure, people familiar with 1-2-3 will find it easy to use.

You can demonstrate the value of 20/20 to yourself simply by taking advantage of our Evaluation Kit offer. Just return the coupon below. Or phone us at (508) 655-9191.

Access
Technology
A CompuServe Company
20/20[™]

- I'd like to receive a 20/20 Evaluation Kit. Please have a sales rep contact me.
- I'm not quite ready to do an evaluation, but I'd like more information about 20/20.

I've attached my business card or letterhead to this coupon.

Send to Access Technology, Two Natick Executive Park, Natick, MA 01760-2030.
Or phone (508) 655-9191.

3-D WORKSTATIONS

Which RISC-Based Workstation Is Best For You?

Who needs a workstation that's more than a "UNIX box" with a 16-inch monitor, a mouse and eight color planes (256 colors)? If you use applications that require solids modeling, volume rendering, scientific visualization, finite element analysis, animation, or image processing, you now can buy a single-processor 3-D workstation with accelerated graphics and a mips rating of over 14 for between \$75,000 and slightly over \$100,000. (Multiprocessing systems such as Apollo's DN10000 or the multiprocessing models of the Silicon Graphics Power series begin at around \$100,000 and are classified as personal supercomputers rather than workstations.)

If you work on compute-intensive problems, create photorealistic images or visualize both the interior and exterior surfaces of complex structures, you may need accelerated graphics, fast floating point calculations and 16 or 24 color planes to do your work effectively. These are the type of applications that used to require a minicomputer, a parallel processing supercomputer or an expensive proprietary graphics workstation.

High-end 3-D graphics workstations are intended for use with applications that are

[P E G G Y K I N G]

more compute-intensive and/or more graphics-intensive than those that run on the less expensive workstations (see *Figure 1*). An engineer involved in modeling and designing complex mechanical parts needs CAD applications that go beyond wire-frame capabilities. Engineering analysts who calculate stresses and study the fluid dynamics of a large aircraft need to do floating point calculations that would overload a less powerful workstation.

A circuit designer creating a VLSI chip needs the color palette, the better resolution and the larger screen that a high-end workstation can offer. An animator in the broadcast industry needs animation capabilities. An architect designing the lighting for a landscaped office needs ray tracing to simulate the reflections and shading from various light sources. A meteorologist converting satellite data to do weather predictions needs image processing capabilities to convert digital signal data.

For a chemical researcher creating new molecular structures from proteins and amino acids, the ability to synthesize these new structures at a workstation can save many hours of laboratory experimentation. A physician or medical researcher evaluating the CAT scan of

a patient's heart can use volume rendering to cut through the surface of the CAT scan data and see the inside tissue without performing surgery.

Now that applications such as these can be done on machines that sell for five-figures instead of six or seven-figures, new applications become available all the time.

Workstation War

WHEN HP INTRODUCED the Model 835 in May 1987, it was the first RISC-based graphics workstation on the market with prices starting at \$59,500 for a 2-D workstation. That was a very competitive price because the price/performance surpassed the competing workstations that had proprietary operating systems and complex instruction sets. Just two months later, Sun introduced its first SPARC-based product, the Sun 4/260 rated at 10 mips.

If 1988 was the beginning of the RISC chip war, 1989 has been the year that the workstation war has moved to higher ground, as the new RISC chips have found their way into graphics workstations. On April 10, Tektronix (Portland, OR) announced its workstations based on the Motorola 88000 chip. Two days later, Sun announced three new SPARC-based workstations including two 16-mips models, the SPARCstation 330 and 370. Three months later, Silicon Graphics (Mountain View, CA) announced new workstations at the low and high ends based on the R3000 chip from MIPS Computer Systems (Sunnyvale, CA). In February, Intergraph (Huntsville, AL) announced a line of workstations based on the Clipper processor, and this fall they plan to introduce two 14-mips machines, the Model 3280 and Model 3285.

Although Sun and Tektronix both sell workstations priced lower than the 835, they include a hard disk in the price of the system. Sun also throws in a 150-MB quarter-inch tape drive. Tektronix includes the DOS emulation program SoftPC in the base configuration for both the 2-D and the 3-D models while HP

users pay \$1,275 for one copy of the same program.

Silicon Graphics and Intergraph have higher base prices on their high-end RISC workstations than HP has on its high-end RISC workstations, but both offer more extras. The Silicon Graphics 4D/210 is the one-processor version of the scalable Power Series that can have up to eight processors. At a base price of \$94,900 for a 20-mips workstation, SGI offers 48 color planes (compared to the eight without a Z buffer that HP offers for its base price) and a 170-MB hard disk drive. When the Intergraph Model 3285 begins shipping, it will have a 27-inch monitor, a 1.2-MB floppy disk drive, and a 670-MB hard disk.

As of mid-August 1989, HP hadn't lowered the price for the 835 TurboSRX or offered a base configuration that includes a disk drive. However, announcements of price cuts and configuration changes were expected by September. Because HP was slow to react to changes in the 3-D graphics marketplace, the pricing and basic configuration of the 835 for more than half of 1989 still reflected the 1987 market conditions when the Model 835 was the only 3-D RISC workstation available. Because HP doesn't bundle a disk drive with its workstation, the peripherals are shipped separately (and in some cases sold separately), and often they don't arrive at the same time the system does. That means there are more boxes and more ways for the customer to get confused.

HP is the only RISC workstation vendor that doesn't offer a SCSI interface or the higher speed SMD. No SCSI for the Series 800 means that HP's offering is less attractive to some customers

who are new to HP workstations because they already may own some SCSI peripherals. HP Series 800 customers wishing to buy third-party peripherals will have a narrower selection because fewer of these vendors still offer the HP-IB interface.

For more information on other vendors' pricing and configurations, see the pricing chart (Figure 2).

At press time, none of the workstations described in this article except the 835 TurboSRX has shipped in volume quantities. The Intergraph 3285 has a

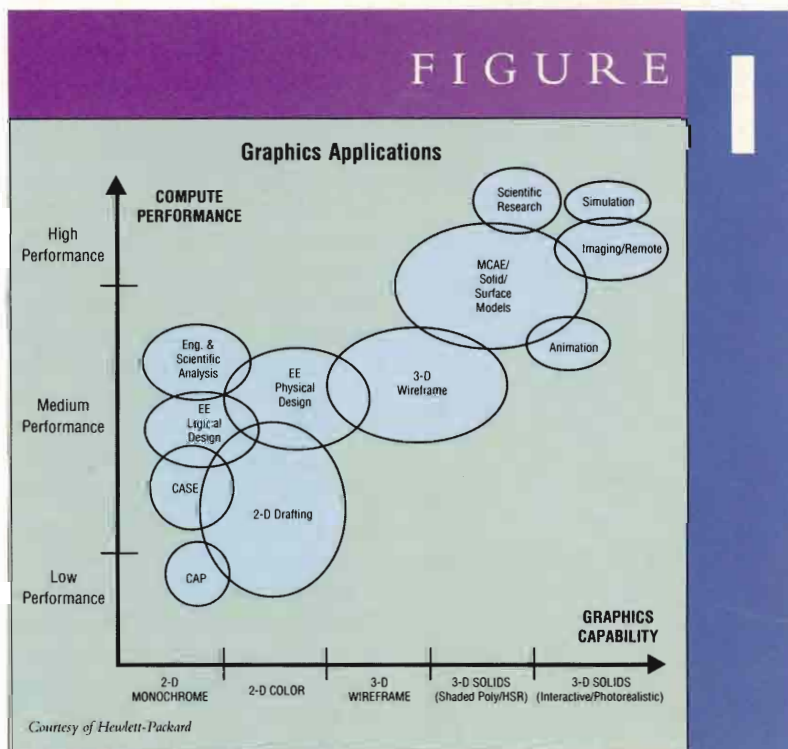

Graphics Applications—Low, Medium and High Performance Systems.

FIGURE 2.

This chart gives the current (August 1989) list price you would pay for a comparably configured accelerated 3-D graphics workstation in each of the model types discussed in this article. Although each vendor configures and prices its workstations differently, we have chosen the following configuration for price comparisons: 19" Color Monitor, 8-MB Memory, 16-bit Z buffer, hard disk drive (approximately 325 MB), 24 plane frame buffer memory (includes 4 overlay planes), PC emulation software. Note: See the "Extras included" category to note where vendors have a standard configuration that exceeds these minimums and see a list of other features included at no extra cost.

Hewlett-Packard

\$63,500 Model 835 TurboSRX Solid Rendering Workstation Standard configuration includes eight frame buffers, no disk drive.	Extras included in base price: Starbase Graphics Library, X Window System
\$15,500 307-MB Disk Drive	\$8,000 Price for additional 8 MB of memory
\$25,000 two frame buffer cards, 16-bit Z buffer, three accelerators	
\$1,275 SoftPC	
\$105,275 Total for sample configuration	

Intergraph

\$71,000 Model 3285 Standard configuration includes 27-inch screen, 16MB 32 frame buffers, 670-MB hard disk drive.	Extras included in base price: large, higher resolution screen, eight extra MBs of memory, a 1.2-MB floppy drive for 5 1/4-inch diskettes, 670-MB disk drive (double size).
\$1,000 Soft PC	\$4,000 Price for additional 8 MB of memory.
\$72,000 Total for sample configuration	The 3285 will become available in late 1989. In the meantime, customers can buy a 3075 workstation and exchange that model for the 3285 at a guaranteed price.

Sun Microsystems

\$40,900 SPARCstation 370 Standard configuration includes 327-MB disk drive, monochrome 19-inch monitor	Extras include Sun graphics libraries, X/NeWS, 156-MB tape drive.
\$8,000 Upgrade to Trinitron color monitor	Price for additional memory: 24 MB for \$15,000, 48 MB for \$20,000 (8 MB memory upgrade is not sold).
\$29,500 TAAC-1 accelerator	
\$495 DOS Windows for PC emulation	
\$78,895 Total for sample configuration	

Silicon Graphics

\$94,900 4D/210 GTX Graphics Supercomputing Workstation Standard configuration includes 72-bit planes, a 24-bit Z-buffer, a 170-MB hard disk	Extras included in base price: Graphics Libraries, Wavefront Personal Visualizer, Voxell Lab for volume rendering
\$3,000 Upgrade from 170-MB to 370MB hard disk	\$8,000 Price for additional 8 MB of memory: (decreasing prices for larger quantities)
\$600 SoftPC Dos emulation	
\$98,500 Total for sample configuration	

Tektronix

\$34,950 XD88/30 3-D workstation Price includes a 16-inch monitor, eight color planes, a 156-MB hard disk,	Extras included: SoftPC for AT emulation
\$16,000 24-bit planes and a Z buffer	\$8,000 Price for additional 8 MB of memory
\$4,000 upgrade from 156MN to 300-MB hard disk	
\$1,500 upgrade to 19-inch display	
\$6,000 4G Graphics Pipeline accelerator	
\$62,450 Total for sample configuration	

Pricing for 3-D Graphics Workstations: Comparisons of Sample Configuration and cost of an additional 8 MB of memory.

graphics subsystem that's still being developed. The integer and floating point performance ratings (see Figure 3) and graphics performance measurements (see Figure 4) use figures that the vendors provided. The degree of precision ranges from HP's exacting 14.8 mips to Tektronix' more ambiguous 14 to 17 mips.

It's very difficult to benchmark graphics workstations because the system's performance depends on how well the CPU and the graphics subsystem work together. Within the graphics subsystem, another problem with existing methods of measuring performance by vector and polygon draw rates is that different vendors have different definitions of vector and polygon. Even if vendors agree to define vectors and polygons the same way, draw rates can't be compared accurately unless the systems have identical screen resolutions. (See "Computer Graphics" in the July issue for more information on the difficulties of evaluating graphics performance.)

Instead of attempting to interpret performance ratings, I'll summarize the way the vendors describe the subsystems responsible for the accelerated graphics in their workstations. I defined accelerated graphics systems as those that have a minimum of 24 color planes and a Z buffer for hidden surface removal. HP, Sun and Tektronix graphics workstations have accelerator units that offer performance enhancements over the basic unit and are purchased separately. Silicon Graphics 4D/210 and the Intergraph 3285 have accelerated graphics as part of the basic configuration.

HP's TurboSRX accelerator was introduced at the National Computer Graphics Association (NCGA) show in April 1988, about a year after the basic unit began shipping. This accelerator also works with the less expensive Models 350, 360 and 370 based on complex instruction set computing (CISC) chips from Motorola.

According to Don Stewart, product marketing manager at HP's workstation division, HP designed the TurboSRX to provide a broad band solution across applications. The graphics transform engine uses three 32-bit VLSI floating point ICs (an adder/subtractor, a divider and a multiplier) to maintain constant performance. For example, HP did extensive testing to ensure that the system can use multiple light sources without degrading system performance. Because the transform engines are general purpose rather than special purpose, they can run in parallel and share the workload of intensive applications.

Andy Barlow, graphics marketing engineer at HP's workstation division, points out that the firmware included with the display processor is designed to make applications run faster. For example, cursors are implemented in firmware so that application performance won't be degraded by dragging the cursor. There are also up to 16 light sources implemented in firmware. For applications where true color (24 bit, 16.7 million colors) isn't needed, hardware dithering provides 24-bit color quality using 8 bits.

Silicon Graphics also provides microcoded instructions in its graphics subsystem. According to Paul Koontz, product line

Looking for Better Access to Your Information? Look to VISIMAGE PC.

File	
New	
Open...	F3
Save	F2
Save As...	Shift+F2
Execute	F10
Key Offline	Shift+F10
Delete...	
Exit	Alt+X

Expressions	Attributes	Title	Output	Options																																			
<table border="1"> <thead> <tr> <th>Items</th> <th>Expressions</th> <th>Sort</th> <th>Break</th> <th>Total</th> </tr> </thead> <tbody> <tr> <td>1</td> <td>CUST-NO</td> <td>Asc</td> <td>Yes</td> <td></td> </tr> <tr> <td>2</td> <td>CUST-NAME</td> <td></td> <td></td> <td></td> </tr> <tr> <td>3</td> <td>PROD-DESC</td> <td></td> <td></td> <td></td> </tr> <tr> <td>4</td> <td>QUANTITY</td> <td></td> <td></td> <td>Total</td> </tr> <tr> <td>5</td> <td>SELL-PRICE</td> <td></td> <td></td> <td>Total</td> </tr> <tr> <td>6</td> <td>QUANTITY * SELL-PRICE</td> <td></td> <td></td> <td>Total</td> </tr> </tbody> </table>					Items	Expressions	Sort	Break	Total	1	CUST-NO	Asc	Yes		2	CUST-NAME				3	PROD-DESC				4	QUANTITY			Total	5	SELL-PRICE			Total	6	QUANTITY * SELL-PRICE			Total
Items	Expressions	Sort	Break	Total																																			
1	CUST-NO	Asc	Yes																																				
2	CUST-NAME																																						
3	PROD-DESC																																						
4	QUANTITY			Total																																			
5	SELL-PRICE			Total																																			
6	QUANTITY * SELL-PRICE			Total																																			
<table border="1"> <tr> <td>Title 1</td> <td>Customer</td> <td></td> <td></td> <td></td> </tr> <tr> <td>2</td> <td>Number</td> <td></td> <td></td> <td>Justify Title: Left</td> </tr> <tr> <td>Format</td> <td>zzz9</td> <td></td> <td></td> <td></td> </tr> <tr> <td>Print</td> <td>No</td> <td>Condition:</td> <td></td> <td></td> </tr> <tr> <td>Comment</td> <td colspan="4">Sort by CUST-NO, but don't print it.</td> </tr> </table>					Title 1	Customer				2	Number			Justify Title: Left	Format	zzz9				Print	No	Condition:			Comment	Sort by CUST-NO, but don't print it.													
Title 1	Customer																																						
2	Number			Justify Title: Left																																			
Format	zzz9																																						
Print	No	Condition:																																					
Comment	Sort by CUST-NO, but don't print it.																																						
Define items/expressions to list.																																							
Display	Remote Ready	10:01	List	17 ORDERS																																			

Items
CUST-ADDRESS
CUST-NAME
CUST-NO
CUST-TOT-ORDER
CUST-ZIPCODE
DAY
INV-DATE
MONTH
ORDER-DATE
ORDER-NO
PAYMENT-MODE
PROD-DESC
PROD-NO
QUANTITY
SELL-PRICE
STOCK-CURR
STOCK-MIN
884/824

Output	
(*) Display	
() Host printer	
() Local printer	
() Host file	
() Local file	

Your End User's Window to Report Writing and Downloading.



PC End User Solution

VISIMAGE PC creates a friendly, yet powerful, environment of pull-down menus and pop-up windows for your PC users connected to the HP 3000. Powerful calculation and conversion macros can be predesigned for end user automation and maximum ease of use.



Terminals, Mac's, and PC's

VISIMAGE 3000 runs on all HP terminals, Macintosh computers, and PC's running in terminal mode.



Custom Tailored Reports

Create simple lists or extensive reports from multiple databases with multiple datasets, focusing on specific ranges and series of items.



Automatic Downloading

Automatically retrieve and import data into almost all PC and Macintosh Applications.



Tailored to Many HP 3000 Applications

VISIMAGE has been customized for use with many popular HP 3000 applications, including manufacturing packages like AMAPS and ASK's MANMAN/OMAR systems.



Powerful Features

- Multiple Dictionary Capabilities (including HP, COGNOS and your own.)
- Automatic links between multiple datasets and databases.
- Runs on any network that supports Reflection
- Built-in Omnidex interface
- Access IMAGE databases, KSAM, MPE, and SD Files
- Easy multipass reporting.

All this and more!

Call us today for a FREE self guided PC demo diskette!

VITAL
Soft

A COGEOLOG COMPANY

Outside California Only, Call

1-800-VITALSOFT

1916 Old Middlefield Way, Suite E,
Mountain View, CA 94043 (415) 965-4494

HP and IMAGE are trademarks of Hewlett-Packard Co.
Macintosh is a trademark of Apple Computer
AMAPS is a trademark of MSA
MANMAN/OMAR is a trademark of ASK Computer Systems
Reflection is a trademark of Walker Richer & Quinn, Inc.
OMNIDEX is a trademark of DISC
VISIMAGE is a trademark of COGEOLOG

CIRCLE 186 ON READER CARD

manager for the Silicon Graphics' Power Series, the geometry engine of the 4D/210 has over 500 commands built into firmware to facilitate different shading methods, polygon drawing, hidden surface removal and other graphics functions. Unlike the TurboSRX, the Power Series is designed for interactive animation. (HP's animation solution comes in the form of the Nimbus interface, introduced in July 1988 for weather mapping and other applications that require real-time playback of pre-calculated images.)

Silicon Graphics takes the pipeline approach to its graphics subsystem which it calls a geometry engine. In contrast to the general-purpose nature of the TurboSRX's transform engine, Power Series' geometry engine uses five custom processors to perform specific tasks in parallel and independently of CPU activity. The POWERpath architecture includes a Motorola 68020-based utility manager that performs overhead processing tasks so that the graphics subsystem is devoted exclusively to graphics-related tasks.

Like the TurboSRX accelerator, Sun's TAAC-1 Application Accelerator can be used with workstations that have either

RISC-based or Motorola 68000 series processors. Brian Croll, a manager in Sun's Graphics Products Division, explains that TAAC-1 hardware was optimized for use in image processing rather than drawing functions. Another accelerator, the GXP, lists faster polygon and vector drawing numbers, but the GXP has only eight color frames rather than the 24 required for true color.

Sun allows its graphics customers the flexibility to do some of their own graphics programming. The TAAC-1 graphics accelerator is programmable in C and comes with a full C compiler. Included in the \$29,500 price of the unit are extensive software libraries for mathematical functions, hidden surface removal, volume rendering, image processing, panning and zooming.

At the SIGGRAPH show in August, Tektronix announced the 4G Pipeline graphics accelerator for its XD88 workstations. With this accelerator, Tektronix claims that XD88/30 is capable of processing over one million vectors per second and 65,000 polygons per second. The XD88 uses a pipelined architecture similar to Silicon Graphics' in that there are specialized engines

FIGURE 3.

	MIPS rating	RISC CPU CHIP	Floating Point Performance	Clock Speed	Floating Point	Main memory (chip type)	Standard memory configuration	Maximum memory	Cache Memory	# of Expansion Slots	DOS Emulation	Hard Disk drive included for base price	Disk Interface included for base price	Other Disk Interface Options (at additional cost)
HP 835 TurboSRX	14.8	HP-PA licensed by Hewlett-Packard	2 MFLOPS	30	HP-PA FPU	ECC RAM	8 MB	96 MB	128 KB	7	SoftPC \$1,275 license to use \$1,080 add'l. copies	not included in base config.	HP-IB	HP-FL (fiber)
Intergraph 3285	14	Clipper C300 Plus-licensed by Intergraph	9 MFLOPS	50	floating point integrated on CPU chip	ECC DRAMs	16 MB	112 MB	"intelligent cache" 4K-instruction 4K-data on chip	5	SoftPC-\$1,000 base unit includes 1.2-MB 5 1/4-inch floppy	670 MB	SCSI	none
Sun SPARCstation 370 with TAAC	16	SPARC IC-licensed by Sun Microsystems	2.6 MFLOPS	25	T1 8847	SIMMs	8 MB	56 MB	128 KB	12	DOS/Windows \$495	327 MB (up to three units can be added)	SCSI	SMD, ESDI
Silicon Graphics 4D/210	20	MIPS R3000 licensed by MIPS Computer Systems	3.3 MFLOPS	25	MIPS 3010	ECC RAM	8 MB	160 MB	64-KB data 64 KB instruction	4 VME	SoftPC \$600	170 MB (380-MB, 780-MB, & 1.2-GB also available)	SCSI	SMD, ESDI
Tektronix XD88/30 with 4G pipeline	14	Motorola 85100	2 MFLOPS	20	floating point integrated on CPU chip	Parity check RAM	8 MB	180 MB	64 KB (additional 64 KB can be added)	4 per cabinet (up to five cabinets)	SoftPC included in price	300 MB	SCSI	none

3-D RISC Workstations—Comparisons of Processing, Memory Specifications, PC Emulation, PC Emulation and Disk Interfaces.

FIGURE 4.

	Color Monitor Size	Display Size	Graphics Accelerator	ICs in Graphics Subsystem	Type and # of Planes	Z Buffer Size (in bits)	Graphics Standards	Graphics Libraries	3D Vector/second	Gourand-shaded polygon/sec.	Video Out	Digitizer	Display System
HP 835 TurboSRX	19"	1280 x 1024	TurboSRX	Proprietary VLSI	12 8-color 4-overlay (16 or 24 color planes at additional cost)	16	PHIGS, GKS PHIGS+, CGI CBM, X Window, Motif	Starbase Graphics Library	240,000	32,000	Video 300 (Folsom Research)\$5,900 uses HP card cage adapter \$280	HP-HIL Digitizers \$875 to \$1,695	CrystalEyes from StereoGraphics (\$3,990)
Intergraph 3280/3285	27"	1664 x 1248	none used	specs not yet available	32 24-color 4-overlay 4-scratch	24	PHIGS, GKS X Window, Motif	EnvironV	275,000	25,000	FrameGrabber \$8,000	Digitizers priced from \$800 to \$5,000	3D Display Systems available (prices not given)
Sun SPARCstation 370 w/TAAC-1	19"	1152 x 900	TAAC-1 images processing GXP for 3-D graphics	TAAC-1-video RAM, ASICs GXP-2 ASICs three VME boards	(TAAC-1) 32 24-color 8-overlay	16	PHIGS, PHIGS+ GKS, X/News	SunPHIGS, SunGKS plus TAAC application libraries	112,000	15,000	SunVideo \$12,900 (provides video-in too)	Digitizers available from CalComp and GTCO Corp.	3D Display Stereo 3-D from StereoGraphics
Silicon Graphics 4D/210	19"	1280 x 1024	none used	68020 utility manager, Geometry Pipeline has five custom graphics processors	72 48-color 16-alpha 4-window 4-overlay	24	PHIGS, PHIGS+	IRIS Graphics Library	400,000	100,000	Video interface not yet available	Live Video Digitizer from \$6,000 to \$8,500	StereoView \$4,000 (OEMed from StereoGraphics)
Tektronix XD88-30 with 4G pipeline	16"	1280 X 1024	4G Pipeline	62080 Control Parallel pipeline ASICs	12 8-color 4-overlay (16 or 24 color planes at additional cost)	16 or 24	PHIGS, GKS X Window, EGA	Plot 10, STI, OnRamp	340,000	20,000	Digital Video Interface \$8,000	interfaced only	Stereoscopic Viewing \$12,000

Graphics Subsystems and Display Options for 3-D RISC Workstations.

"WE'RE THERE WHEN YOU CALL."

Arthur J. King

Andrea DiBuro

Karen L. Moss

Robyne J. Lavoie

Bonnie L. MacLay

Michael J. Smith

David R. Waldron

Larry Rucker

Jim Shuffleton

ACCOUNTABLE SOLUTIONS

When you consider accounting systems for your HP 3000, you should think about more than just purchasing the software. You should think about what happens after the sale. Your software is only as good as the people supporting it.

SOTAS' experienced technical and application personnel are the best in the industry. They're the same people who introduced the first on-line accounting software for HP 3000 users. They continue to dominate the leading edge of application technology. They're so proud to be part of the SOTAS application team, they have signed their

names in recognition of their commitment to excellence!

Take it from over 600 existing users who say the best part of being a SOTAS HP 3000 user is being able to talk directly with any of these dedicated professionals. You won't be passed

through a "mythical" Customer Service department to someone who just "takes messages." When you call, SOTAS people respond. Quickly, knowledgeable and completely.

SOTAS Accountable Solutions include:

**General Ledger
Accounts Payable
Accounts Receivable
Fixed Assets Payroll
Human Resources.**



Your HP 3000 deserves SOTAS accounting software. You deserve to deal directly with SOTAS people. Because when you call, we're there.

Call SOTAS at (508) 521-1300.



SOTAS
International

192 Merrimack St., Haverhill, MA 01830 Tel: 508-521-1300
London • Sydney • Hong Kong • Paris • Netherlands
Scandinavia • Mexico

for clipping, bit slicing, tiling and hidden surface removal (Z buffer). The 4G graphics board replaces the existing bit slice and transform engines, increases the Z buffer and adds a clipping engine to the pipeline.

Graphics Input And Output Devices

HIGH-END MACHINES USUALLY have some kind of interfaces for input, output and display devices, and sometimes the platform vendors sell these devices. On the input side, a digitizer is a device that converts graphics data into digital form so it can be entered in the workstation. The most common use for digitizers is a means to enter a mechanical drawing into a CAD system.

Video out provides a means of displaying video images in a workstation window. The video images can come from cameras, video disk players or VCRs. Video out can be used for unedited video output and one-frame-at-a-time display. All of these workstations except the TurboSRX have a built-in interface for video out. However, HP 835 customers can use Folsom Research's (Folsom, CA) Video/300 (featured in the July issue) if they buy a \$280 card cage adapter from HP. Sun's recently introduced SunVideo offers full-motion video out. Because it also has real-time video in capabilities, the SunVideo also does the work of a digitizer.

Now that the cost of 3-D viewing systems is declining, these units are increasingly popular with people who use workstations for visualization applications such as molecular modeling or complex circuit layouts. Viewed stereoscopically, 2-D images appear to be 3-D, and 3-D ones appear real enough to reach out and touch. Recently, Stereographics (San Rafael, CA) bought out CrystalEyes, a stereographic unit enclosed in a pair of shuttered goggles. HP demonstrated CrystalEyes at its SIGGRAPH booth this year, and Silicon Graphics sells its version of the StereoGraphics product under the name StereoView. Tektronix's SGS625 viewing system uses a 19-inch color monitor equipped with a shutter. The viewing device is a pair of polarized sunglasses. With the Tektronix screen system, the

Silicon Graphics 2011 N. Shoreline Blvd. Mountain View, CA 94039 CIRCLE 300 ON READER CARD	StereoGraphics Corp. P.O. Box 2309 San Rafael, CA 94912 CIRCLE 294 ON READER CARD
Sun Microsystems Inc. 2550 Garcia Ave. Mountain View, CA 94943 CIRCLE 299 ON READER CARD	Wavefront Technologies 530 E. Montecito Santa Barbara, CA 93103 CIRCLE 293 ON READER CARD
Tektronix Inc. P.O. Box 14689 Portland, OR 97214 CIRCLE 298 ON READER CARD	Deneb Robotics Inc. 1120 E. Long Lake Rd., Suite 200 Troy, MI 48098 CIRCLE 292 ON READER CARD
Intergraph Corp. One Madison Industrial Park Huntsville, AL 35807 CIRCLE 297 ON READER CARD	Creative Visuals P.O. Box 20638 San Jose, CA 95160 CIRCLE 291 ON READER CARD
MIPS Computer Systems 930 Arques Ave. Sunnyvale, CA 94086 CIRCLE 296 ON READER CARD	Wolfram Research P.O. Box 6059 Champaign, IL 61826 CIRCLE 290 ON READER CARD
Folsom Research 526 E. Bidwell St. Folsom, CA 95530 CIRCLE 295 ON READER CARD	PDA Engineering 2975 Red Hill Ave. Costa Mesa, CA 92626 CIRCLE 289 ON READER CARD

cost of having another viewer use the system is \$60 for an additional pair of the sunglasses.

THESE FIVE WORKSTATIONS have similar MIPS ratings, but they vary widely in graphics performance, compute power and the type of applications they're targeted for. Here's a brief rundown of the market positioning of each of the systems described in this article.

HP Model 835 TurboSRX. Despite the widely publicized success of Sun's SPARCware program, HP still has more RISC-based applications running on the 835 than Sun has on the SPARCstations. When it comes to CAD applications, each of the other RISC workstation vendors has a subset of the applications that run on Series 800 workstations. (See Figure 5 for an overview of which CAD vendors have products running on

FIGURE 5.

	CADAM	CADSI	Creare.X Inc.	Deneb Robotics	Engineering Mechanics Research	Fluid Dynamics Int'l.	Hibbett, Karisson and Sorensen	Manufacturing & Consulting Services	ICAD	McDonnell Douglas	Mechanical Dynamics	PDA	SDRC	Swanson Analysis Systems
HP 835 TurboSRX	✓	✓	✓	✓	✓	✓	✓	✓	Port. in Progress	✓	✓	✓	✓	✓
Intergraph 3285					✓	✓							✓	
Sun SPARCstation 370	✓	✓	✓			✓		✓	✓	✓	✓	✓	✓	✓
Silicon Graphics 4D/210		✓			✓	✓	✓	✓				✓	✓	✓
Tektronix XD88/30		✓	✓	✓		✓		✓					✓	✓

CAD Applications Available on 3-D RISC Workstations.

The value of your data is only as good as your access to it.

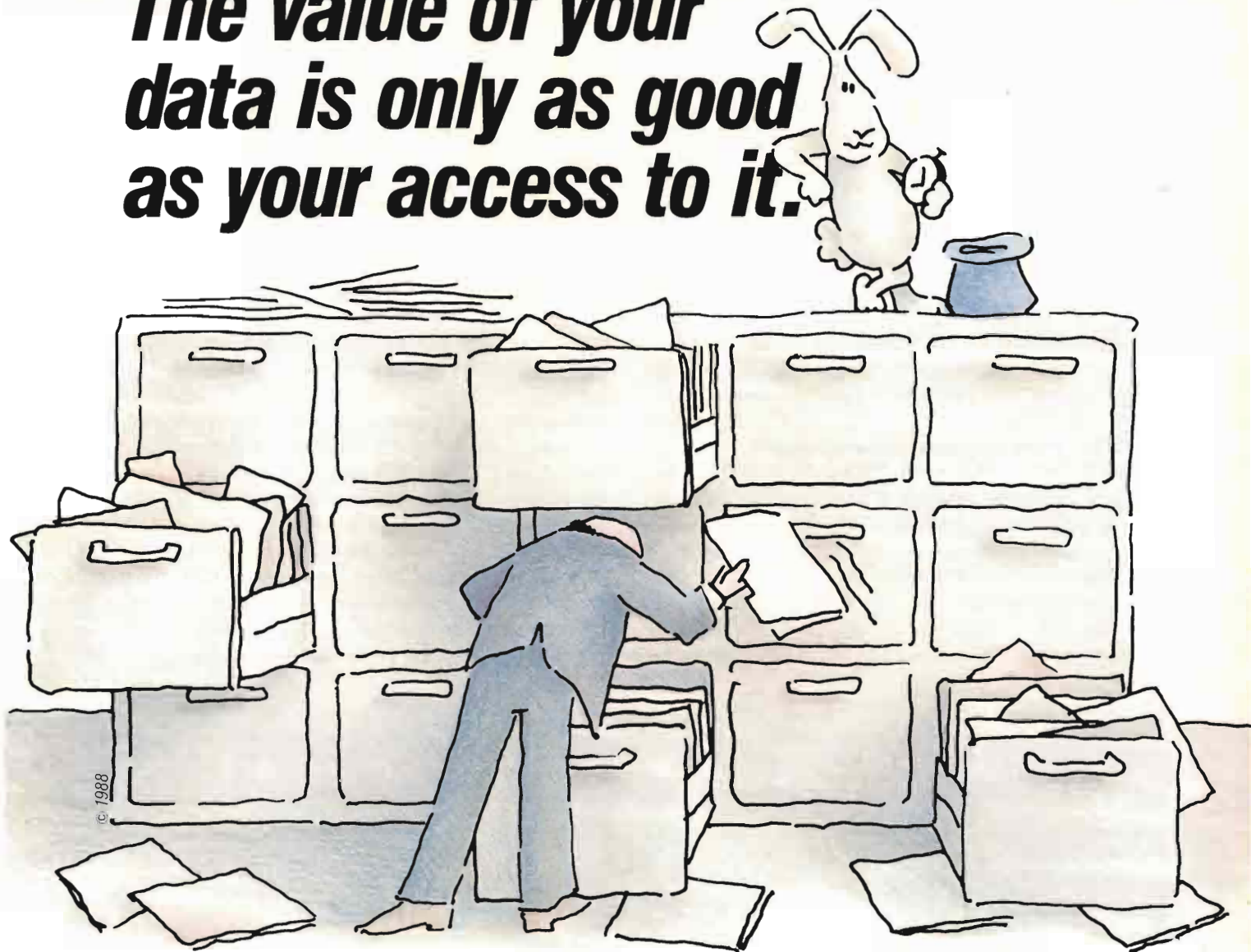

In a way, it's ironic. We invest millions of dollars to develop computerized systems to store information . . . data that is crucial to managing a successful business. Yet the sheer volume and variety of data that we have to store make it increasingly difficult to find the specific information we need to make decisions.

Executive Information Systems (EIS) are the latest approach intended to address the problem. In theory, an EIS should provide "easy access to individually specified mainframe information by non-technical end users."¹ In reality, it can't be done on the HP3000 without OMNIDEX.

OMNIDEX gives users the ability to instantly retrieve records based on multiple field and multiple set selection criteria, keywords and partial key values. Users can access information through all major report writers and with programs written in any 3rd or 4th GL, or use their PCs to retrieve summarized HP data directly into a Lotus 1-2-3™ spreadsheet using OMNIVIEW.

Reports that used to take hours to complete can be done in minutes. Critical information can be retrieved on-line in seconds. Never again will your users have to say, "I know that information is in here somewhere . . ."

DISC
Dynamic Information Systems Corp.

910 Fifteenth Street
Suite 640
Denver, Colorado 80202
(303) 893-0335

In Canada call:
1-800-267-9377

In Europe call:
(44)-372-386838

In Australia and New Zealand call:
(02) 484-3979

¹"The Three Pillars of EIS" by David Friend, August 1988

™ Lotus 1-2-3 is a registered trademark of Lotus Development Corporation

high-end RISC workstations.)

HP 9000s have been popular with geologists, surveyors, topographers, seismologists and meteorologists since the days of the Series 9800. Therefore, it's no surprise that HP customers have the best selection of Earth Resources and Geographic Information System (GIS) software. Animation is another strong market for HP workstations. Animation software from Wavefront (Santa Barbara, CA), Deneb Robotics (Troy, MI) and Creative Visuals (San Jose, CA) offer animation capabilities for a broad range of applications.

Emerging markets for HP workstations include molecular modeling, medical imaging and mathematical analysis packages like Mathematica from Wolfram Research (Champaign, IL). However, the TurboSRX isn't a popular choice for AEC (architecture, engineering and construction) applications.

SPARCstation 370 with TAAC-1. Although the SPARCware catalog lists hundreds of applications, if you bought a high-end SPARCstation with the TAAC-1 accelerator, chances are that you'll be using the extensive software libraries and C compiler in the TAAC-1 to do your own programming. Most likely you would use the TAAC board for compute-intensive applications such as image processing, scientific visualization, volume rendering or medical imaging. Because the SPARCsta-

tion 370 has binary compatibility with other SPARC systems, you also have a wide selection of commercial software packages should you wish to use your system as a general-purpose computer.

4D/210. The Silicon Graphics Power Series targets high-end users in a wide range of industries including broadcasting, defense and aerospace, chemical and pharmaceutical, medical research and construction-related trades. The Geometry Partners directory has listed hundreds of applications that run on the 4D/210. The longest listings are in the sections for AEC software, Earth Resources Management, Life Sciences (chemical and medical) and Mechanical Engineering (both design and analysis).

The Wavefront Personal Visualizer software that comes with the 4D/210 can be used to develop 3-D photorealistic images from existing geometrical data. If you use Patran from PDA (Costa Mesa, CA), you can get a translator from Wavefront that allows you to import data from your CAD database.

XD88/30. Because the new Tektronix 2-D and 3-D workstations are not compatible with the previous CISC-based models, any software vendor wishing to run on the RISC platform needs to port its application. As of August, there were less than two dozen completed ports, and most of these were CAD

[APOLLO OFFERS LOW COST ACCELERATED GRAPHICS PERFORMANCE]

If you want fast graphics processing but can't spend over \$60,000 for a system, and if you can make do with a 4 mip DN3500 or a 7 mip DN4500 instead of a RISC workstation that has at least 14 mips, the Apollo division of HP has a solution: a low-cost Desktop Visualization System (DVS) scheduled to ship late this year.

Apollo is offering two versions of a graphics accelerator, one with 8 color planes and the other with 40. This DVS works with either the DN3500 or the DN4500. The speed of the DVS isn't limited by the workstation's bus speed because Apollo has eliminated the bus by connecting the accelerator via a private 32-bit connector.

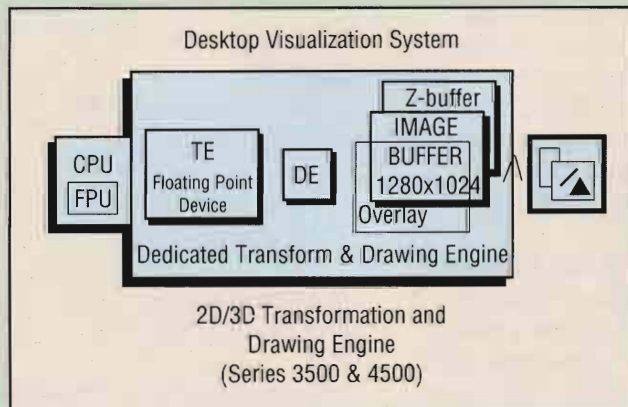

The DVS has a transform engine that uses a Weitek floating point chip, a drawing engine with custom chips, and an image buffer with video RAM chips.

The image buffer is available in an eight color plan version for 2-D applications. 3-D applications require the 40-plane DVS that provides 24 image planes, a 16-bit Z buffer and two overlay planes. Apollo rates the performance of the 3-D DVS at 290,000 3-D vectors per second on the DN35000 and 300,000 on the DN4500. With the DVS, the DN3500 can form 15,000 Gouraud-shaded polygons per second and the DN4500 can form 20,000.

As an introductory promotion, Apollo is bundling a system that includes a diskless workstation with 8 MB of memory, a 348-MB disk drive and a 19-inch, 1280 x 1024 monitor along with the 3-D accelerator for \$27,495 with a DN35000, or \$34,990 with a DN4500. During the promotion, customers who prefer a 700-MB disk drive can obtain the unit for half price. This system costs \$34,995 with the DN3500; \$42,990 with the DN4500.

If you want to do 3-D graphics on a DN4500 or DN3500 that you already own, Apollo sells the DVS as an upgrade option. If your systems already has the F option (a 2-D graphics accelerator with a drawing engine) and a high resolution monitor, you can get the 40-plane DVS for \$11,500. If you have Basic Graphics option with a lower resolution screen and the frame buffer on the bus, the upgrade to 3-D graphics will cost \$15,000 if you had a color monitor or \$15,500 if your original monitor was monochrome. — Peggy King

IN ORDER MANAGEMENT SOFTWARE:

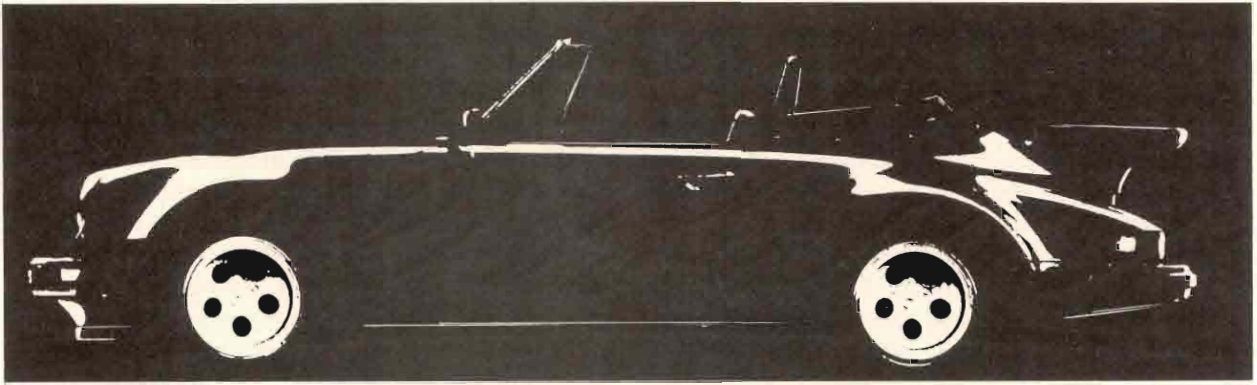

THERE'S CUSTOM.

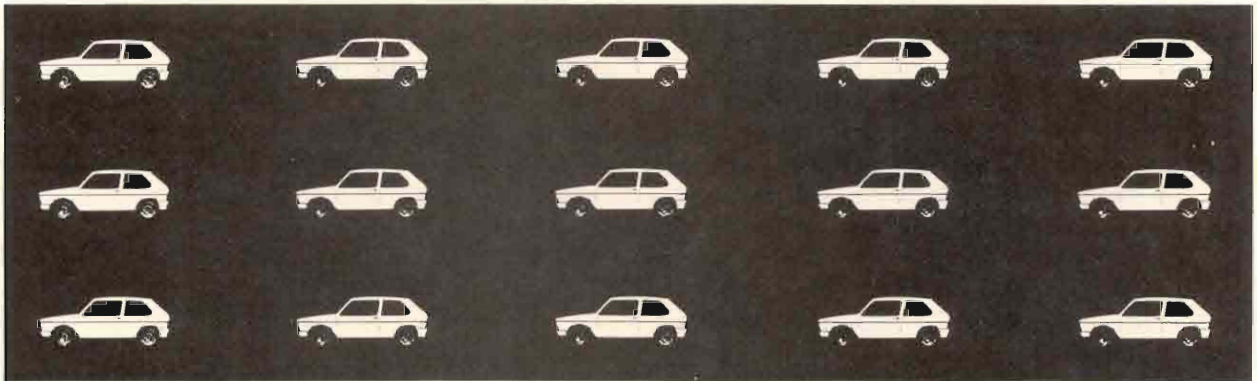

THERE'S CANNED.

If you think it costs a fortune to have software tailored to your company's exact sales and purchase order requirements, think again. Cardinal's unique approach to order management gives you the fit and functionality of a custom solution for about the price of a canned package. The secret: the Cardinal Configurator, an exclusive architec-

ture that lets you specify, in detail, an unlimited number of order types and how each is processed. If your needs change, your systems can change with them—with no reprogramming.

Why settle for a canned solution? Or spend a fortune on custom? Call Cardinal. And get the best of both worlds.

AND THERE'S CARDINAL.



Cardinal Data Corp., 75 Second Avenue, Needham, MA 02194 • (617) 449-0066

Distributors: Indianapolis (317) 781-1111 • Los Angeles (714) 554-1551

Toronto/Montreal (416) 844-9947 • Melbourne/Sydney (03) 874-3633



INTEGRATED SOFTWARE FOR: ORDER MANAGEMENT • PURCHASING • INVENTORY • RECEIVABLES • PAYABLES • GENERAL LEDGER

CIRCLE 108 ON READER CARD

applications. XD88 users also can run software packages available through 88open's software initiative. Although Tektronix intends for the XD8830 to be used for seismic databases, molecular modeling and scientific visualization, there are no completed ports in these application areas except for one earth resources application. Wavefront's Advanced Visualizer software is available for animation and rendering applications.

Intergraph 3285. Intergraph has a binary-compatible line of InterPro 3000 workstations based on the Clipper chip. Therefore, when the top-of-the line Model 3285 workstation becomes available, Intergraph customers will have a whole catalog of software available, most of it created in-house. Unlike the vendors who are hoping to capture market share in a wide range of application areas, Intergraph is more interested in providing turnkey solutions for mechanical and electronic designers who like the large screens for studying complex layouts. The company even sells a range of other vendors' digitizers and display devices. In addition to CAD and electronics software packages, Intergraph also targets the AEC market with a number of its own packages.

Mips and MFLOPS, vector and polygons, pixels per second and refresh rates are not always accurate guidelines for deciding which machine gives your company the most for its money. In many cases the decision may hinge on what optional features come standard on the machine. For example, which would be more useful to you: the 1.2 floppy drive on the Intergraph 3285, the Starbase graphics libraries from HP, the Wavefront Personal Visualizer software that SGI offers with the 4D/210,

PC emulation software available at no extra charge from Tektronix or the tape drive unit that Sun bundles with the SPARCstation 370?

If you already know what software package you intend to use, you may want to talk to people at the software company that sells the application you have chosen. They may be willing to give recommendations about which platform runs their software the fastest. If you sense a reluctance to reveal which platform is their best performer, you can try phrasing the question indirectly. Simply ask which platform is the easiest and most straightforward to port. That platform may be the one best suited to your application.

If you are determined to do thorough benchmarking before you buy a graphics workstation, wait six months before you make a decision. Benchmarking is soon to become easier. All five of the platform vendors offering RISC-based 3-D graphics workstations are participating in the Picture Level Benchmark (PLB) developed by the Graphics Performance Characterization (GPC) project. NCGA plans to put the PLB source code in the public domain in March 1990. You will be able to specify your own data and use it in the benchmark program. It's a long wait and a lot of work, but running a suite of GPC benchmarks may be the only way to determine which machine is best for your purposes, especially when the alternative method is to choose the vendor whose brochure has the best-looking pictures.

Would you like to continue to see articles on this topic?
Circle on reader card
yes 344 no 343

[GLOSSARY OF GRAPHICS TERMINOLOGY]

Below is a list of computer graphics terms used in this article. Some of these definitions have appeared in Hewlett-Packard training literature.

Digitizer — A device that converts graphics information into digital form so that it can be entered into a computer.

Dithering — The technique of placing different colored pixels next to each other so that the colors will appear blended, thereby increasing the number of colors that appear to be on the screen.

Frame buffer — Memory used to store pixel data (images).

Gouraud shading — A computationally intense technique used to render 3-D objects by interpolating the color and intensity of each pixel.

Hidden surface removal — The process of storing depth information from line segments that are obscured from view in the current rendering of an object.

Image processing — The process of taking real-world data, digitizing it, then rendering and displaying the processed data.

Photorealism — A technique of rendering images so that they appear like a photograph of the actual object.

Ray tracing — A method for approximating the way a scene is

lighted. Ray tracing is used to produce realistic highlights and reflections.

Solid modeling — A method that builds 3-D models by building the solid characteristics of an object into a database so that complex internal structures and external shapes can be realistically represented.

Transform engine — The part of a graphics subsystem that takes the 3-D information about an object and calculates what the user would see by rotating, scaling or translating the object.

Video in — The capability to take a video signal, digitize it and project it on a screen.

Video out — The capability to send a video signal to a VCR for copying, to a TV monitor or video projector for viewing, or to other equipment that can change or improve the signal.

Visualization — The use of computers for graphic depiction of masses of scientific data in ways that are easy to understand.

Volume rendering — A technique for graphical representation of the inner area of an object.

Z buffer — Memory that stores the depth information of a pixel that is used for hidden-surface removal.

If 37 people are waiting on you for a printout, tell them to

“Just Do It Yourself”

Does every one come to you for their reports and printouts?

And they always want them right away? Now you can tell them to “Just do it yourself” with StarJet/3000.

No more waiting for printouts. And no expensive forms to change for each type of report.

StarJet/3000 is the business form software designed for users of Laserjet printers connected to the HP3000.

With StarJet/3000, anyone can direct their report or form output from the HP3000, or PC terminal, to a Laserjet rather than to a central printer.

It's the *only* Laserjet solution which combines *PC-based form design* and *file equation technology* in one single product.

Plus our new PrintJet companion program gives your forms style. It lets you format flat files using all the possibilities of the Laserjet. You can easily change fonts, print logos, signatures, pictures, boxed and shaded areas and lines. You can print bar codes, format

labels and generate multi-form reports.

PrintJet is a great companion program for formatting fourth generation

language output. You

create instant forms without ever changing your existing HP3000 programs.

With StarJet/3000 you have immediate access to data from your programs, merged with the form of your choice.

Or download data directly from the HP3000 to your PC and design your report to your information, right on the screen.

And yes, for those of you who need help getting started, we have customer support standing by.

Send for more information today. Demo tapes also available.

Call now.
512/346-0962.



StarJet/3000 Software by APPIC



For a complete list of worldwide distributors call or write: APPIC USA, Inc., 7901 Haverwood Drive, Austin, Texas, 78759, 512/346-0962
APPIC-FRANCE, 123, rue de Petit-Vaux, 91360 Epinay sur Orge, 1-64 54 87 37
MANDATA, Hohenzollernstr. 56, 4150 Krefeld 1, W. GERMANY, (0 21 51) 59 00 14
SYDES, Brusselpoortstraat 8, B-2800 Mechelen, BELGIUM, (015) 42 22 72
OLE NORD AB, Strandvagen 39, 191.45 Sollentuna, SWEDEN, (46) 835 46 66

CIRCLE 161 ON READER CARD

Apollo Adds Punch To HP Line



LOW-END WORKSTATION MARKET

[BY BILL SHARP]

Shopping at the fancier workstation stores can be frustrating. You pile your shopping cart high with wondrous widgets boasting multitudinous mountains of mips (millions of instructions per second), awe-inspiring applications and glittering graphics, only to find that your terrific taste has broken the bank — so let's go bargain hunting. Forget the 120-user systems and the 3-D graphics. Tell me HP, what can you sell me for under \$10,000? What will it do, and when I'm ready to make my own comparison, what competing products should I consider?

HP has a broad family of products in this range, including too many PC products to list, in addition to its line of 68000-based workstations. With the addition of the Apollo line to HP, the family becomes an even more extensive one. HP and its Apollo division have enough selections to make your choice a difficult one even before you consider competing products. Here is a discussion of HP products in the workstation marketplace, some of the major topics that help make purchasing decisions, and a rundown of the current product lineup.

The decision on what product to use comes down to determining what software best meets your needs, and picking the hardware that supports that software at the level you require.

This may be general, but it makes the point that what you call the hardware will increasingly be irrelevant — buy what works for you and ignore the labels.

So, what is the rock bottom price from HP? The HP Vectra PCs actually set the lowest prices available from HP. But, they aren't workstations in terms of mips ratings, UNIX system availability, integrated graphics or distributed file sharing, and other areas of higher-level functionality that has made workstations so valuable in the marketplace.

This isn't a function of the processors used; in some cases, PCs and workstations use the same ones (Sun's 386i/150 is based on a 20MHz 80386). Workstations and PCs are generally structured differently around the processors. High-end PCs can become inefficient and costly, while low-end workstations may give up some of the functionality that makes them so desirable.

HP's current price list shows some 44 different models of PCs, including two portables. They begin at \$1,699 for an 8086-based Model 10 without hard disc, video adapter or monitor. The high end is \$14,399 for the Model 304e, with a 310-MB disc, based on a 25MHz 80386, but still excluding the video adapter and monitor. Pick any price point between these two, and there's a product sitting there. And let's face it, you can spend more if you want to.

Apollo Adds Punch To HP Line

APOLLO'S FIRST PRODUCT INTRODUCTION since joining HP makes a solid price contribution to the market with the DN2500, based on the Motorola MC68030 with a companion MC68882 floating point coprocessor, both running at 20MHz. With prices in the workstation market generally sneaking upward, Apollo has dropped the entry-level price for a diskless workstation to \$3,990. This is \$1,500 lower than the previous entry-level price for an HP diskless workstation (HP 9000 340M and Apollo DN3000, both at \$5,495). For comparison, Sun's entry-level price for a diskless 3/80 is \$5,995, while Digital's entry-level price for a diskless VAXstation 2000 is \$5,238.

The new Apollo DN2500 isn't a stripped-down version of a more expensive workstation. Apollo designed it specifically to "set a new low-priced standard for the market, while providing significant performance." The DN2500 runs at 3.5 mips, outperforming the low-end offerings from Digital and Sun, both rated at 3.0 mips.

Apollo's John Thompson,

senior product manager for personal workstations, cited the use of a single motherboard design as a significant factor in price reduction. Using ASICs to reduce the number of components made it possible to produce a single board and take advantage of more efficient, low-cost production methods.

Thompson also noted the use of new mechanical designs. "We designed an integrated injection-molded plastic case for the 2500. We also used thermal design simulation development techniques so that we could produce very efficient, very quiet and cool packaging. By doing this, we eliminated a number of components." The new case opens when you depress two tabs — no screws.

Small Prices, Big Sales

THE LOW-END OF THE WORKSTATION marketplace isn't as flashy as the 3-D graphics systems or the beefy RISC-based systems, but the fact is that systems in the lower-priced end of the market account for a disproportionately large percentage of sales. Bob Weinberger, Apollo's director of Systems Product Marketing, notes that systems selling for less than \$15,000 account for about half of workstation market sales. UNIX systems tend to be concentrated in this low-priced range, he adds.

Most customers are buying low-end workstation systems for their applications because these systems can meet the vast majority of their needs. The Apollo division's DN2500, even with the lowest workstation price available, was planned for use in a number of different markets, according to Apollo's Thompson.

"Our target markets are focused in computer-aided software engineering (CASE), artificial intelligence and database applications, where users are looking for computational power, large displays and disc capacities in the 100 to 200 MB range."

Thompson also lists electronic publishing, which is a price sensitive market that requires computational power for speed, and will use monochromatic systems. He also has targeted computer integrated manufacturing (CIM), where the small-

screen version will be used on the factory floor. In addition to these primary markets, Thompson also sees the DN2500 doing well in integrated office systems, electronic simulation and mechanical drafting.

Low-end systems are well suited for applications up through 2-D CAD, particularly with the larger internal memory now provided, and computational power above three mips. Bringing prices down well into the PC range should make possible increased

With prices in the workstation market generally sneaking upward, Apollo has dropped the entry-level price for a diskless workstation to \$3,990.

penetration into markets and distribution methods typically dominated by PCs.

Weinberger alluded to considerations of more innovative marketing in the future, but noted, "The real opportunity is

putting workstation functionality on more desktops. We're not necessarily creating new markets, but we are fundamentally altering existing ones. Individuals who really wanted a workstation but felt they had to go with a PC because of a perceived

FIGURE

	Mips	Processor speed	Coprocessor speed	RAM in MB	Interfaces	Graphics	Monitor	Diskless price	Price with disk
HP 340M Monochrome Workstation	4	MC 68030 16.67MHz	MC 68882 16.67MHz	4 MB, expandable to 16 MB	32-bit memory bus IEEE-488 (HP-IB) RS-232C Serial IEEE 802.3/Ethernet LAN HP-HIL	1024 x 768	17" high-resolution monochrome	\$5,495	\$9,070 (81 MB)
HP 340MH 2-D Monochrome Workstation	4	MC 68030 16.67MHz	MC 68882 16.67MHz	4 MB, expandable to 16 MB	32-bit memory bus IEEE-488 (HP-IB) RS-232C Serial IEEE 802.3/Ethernet LAN HP-HIL	1280 x 1024	19" high-resolution monochrome	\$7,995	\$11,570 (81MB)
HP 340C+ Color Workstation	4	MC 68030 16.67MHz	MC 68882 16.67MHz	4 MB expandable to 16 MB	32-bit memory bus IEEE-48 (HP-IB) RS-232C Serial IEEE 802.3/Ethernet LAN HP-HIL	1024 x 768 6-plane color with RGB cable	16" high-resolution color monitor	\$8,495	\$12,070 (81 MB)
Apollo DN 2500 (15" monitor)	3.5	MC 68030 20MHz	MC 68882 20MHz	4 MB expandable to 16	32-bit memory bus SCSI (up to 7 devices) SIO (3 lines) Apollo Token Ring, Ethernet, or IBM Token	1024 x 800 76Hz, non-interlaced	15" monochrome	\$3,990	\$5,490 (100 MB)
Apollo DN 2500 (19" monitor)	3.5	MC 68030 20MHz	MC 68882 20MHz	4 MB expandable to 16	32-bit memory bus SCSI (up to 7 devices) SIO (3 lines) Apollo Token Ring, Ethernet, or IBM Token	1280 x 1024 70Hz non-interlaced	19" monochrome	\$5,495	\$8,495 (200 MB)
Apollo DN 3500 (15" monitor)	3.0	MC 68030 25MHz	MC 68882 25MHz	4 MB expandable to 16	32-bit memory bus SCSI (up to 7 devices) SIO (3 lines) Apollo Token Ring, Ethernet, or IBM Token	1024 x 800	15" monochrome	\$8,490	\$12,990 (155 MB)
Apollo DN 3500 (15" color monitor)	3.0	MC 68030 25MHz	MC 68882 25MHz	4 MB expandable to 16	32-bit memory bus SCSI (up to 7 devices) SIO (3 lines) Apollo Token Ring, Ethernet, or IBM Token	1024 x 800	15" color	\$8,495	\$11,495 (155 MB)
HP Vectra CS PC Model 10	NA	8086 7.16 MHz	NA	640 KB	HP HIL, Serial, Parallel	640 x 480	14" monochrome	\$2,543	\$2,948 (20 MB)
HP Vectra QS PC Model 16S	NA	80386SX 16 MHz	NA	1 MB	HP HIL, Serial, Parallel	640 x 480	14" monochrome	\$4,139	\$4,744 (40 MB)
HP Vectra RS PC Model 25C	NA	80386 25MHz	NA	1 MB	HP HIL, Serial, Parallel	640 x 480	14" monochrome	\$8,193	\$10,393 (103 MB)
Sun 3/80	3	68030 20MHz	68882 20MHz	4 MB	Ethernet, Serial, Parallel, SCSI	1152 x 900	17" monochrome	\$5,995	\$7,995 (104 MB)
Sun 386i/150	3	80386 20MHz	80387 20MHz	4 MB	Ethernet, Serial, Parallel, SCSI	1024 x 768	15" monochrome	\$9,490 (8 MB RAM)	\$8,990 (91 MB)
SPARCstation 1	12.5	SPARC 20MHz	SPARC 20MHz	8 MB	Ethernet, Serial	1152 x 900	17" monochrome	\$8,995	\$10,999 (104 MB)
VAXstation 2000	1.2	MicroVAX II	FPU	4 MB	Ethernet	1024 x 864	15" monochrome	\$5,238	\$8,038 (71 MB)
VAXstation 2000	1.2	MicroVAX II	FPU	4 MB	Ethernet	1024 x 864	15" color	\$8,538	\$11,338 (71 MB)
VAXstation 3100	3	MicroVAX CMOS	FPU	8 MB	Ethernet, Serial	1024 x 864	19" monochrome	\$7,950	\$10,350 (104 MB)
DECstation 2100	10	R2000/12.5MHz (RISC-based)	R2010 12.5MHz	8 MB	Ethernet, SCSI Printer, modem	1024 x 864	15" 19"	\$7,950(15") \$8,550(19")	\$10,350(15") (104MB) \$10,950(19") (104MB)

The low-end workstation lineup.

Eliminate Data Bottlenecks with Intelligent Interfaces

*DON'T TOUCH!
Plot in Progress*

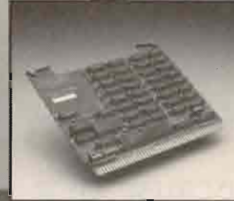

HPiB Buffers

MicroPlot 80 Series

free HP CAD/CAM/CAE work stations from time-consuming data output. Gain at least 5:1 improvement in computer utilization.

- Expandable 256K - 8 megabyte memory
- Multiple copy & plot queuing eliminate delays
- Full status monitoring
- Prices start at \$995

MicroPlot 70 Series

Ideal for large printing or small plotting applications.

- Expandable 256K - 1 megabyte memory
- Plot queuing, pause, copy and purge functions
- Prices start at \$845

RS-232 Buffers

MicroPlot 55 Series

free 286/386 PC workstations. Realize all the computer utilization efficiencies during printer/plotter operations as the MicroPlot 80/70 Series. Same features plus:

- Automatic learn mode for end-of-plot sequences
- Supports all popular hardware/software protocols including "HP-Mode"
- Baud rates > 100K baud
- Prices start at \$895

HP 200/300 Memory Expansion Board

MicroRAM - \$775

1 megabyte memory expansion board for HP Series 200/300 computers.

- Easy snap-in installation
- Fully compatible with HP boards
- Switch selectable addressing

GPiB-1000 - \$219

IEEE-488 interface card for PCs and compatibles.

HPiB ↔ Centronics Converters

MicroPrint 45 Series

Has become the industry standard to reliably interface Centronics printers with HP computers (45C), or HPiB peripherals to PCs (45H).

- No programming needed
- Transparent to operating system
- Switch selectable HPiB address/Listen Always
- Prices start at \$209

call 800-842-0888

High-power HP and PC users shouldn't have to wait for output or be restricted in choice of peripherals. Allow us to be your single source for cost-effective interfaces. With each product comes a one-year parts and labor warranty AND 30-day money-back guarantee. 24-hour service is standard.

I INTELLIGENT INTERFACES Inc.

P.O. Box 1486
Stone Mountain, GA 30086-1486
404-381-9891 • Telex 9102502628

CIRCLE 170 ON READER CARD

SPEED

Edit

- MS-DOS
- MICROSOFT WINDOWS
- OS/2
- PRESENTATION MANAGER
- UNIX
- MPE/MPE-XL

The Only Editor You Need to Know.

FULL SCREEN TEXT EDITING

SpeedEdit is an all new, state of the art, full screen text editing system designed for the professional programmer. The SpeedEdit system is the first programmers editor for MS-Windows® and Presentation Manager® as well as being the first text editor with Remote Program Development (RPD) capability. SpeedEdit is the first in many other areas as well, and of course SpeedEdit has powerful features like multiple

windows, keyboard macros, compilation, regular expressions, and all of the normal editing functions as well.

SpeedEdit is acclaimed as the most capable, yet easiest to use, text editing system available today. In addition to all this, SpeedEdit is available on a wide variety of operating systems and platforms, making SpeedEdit the only editor you need to know.

Versions of SpeedEdit are available for Windows, PM, non-windowed DOS or OS/2, and HP-UX® on the HP-9000 as well as MPE and MPE-XL on the HP-3000. Give us a call for more information on this exciting family of products.

BRADFORD BUSINESS SYSTEMS, INC.

25301 Cabot Rd., #201
Laguna Hills, CA 92653
(714) 859-4428

MS-Windows and Presentation Manager are trademarks of Microsoft, Inc. HP-UX and MPE are trademarks of Hewlett-Packard, Inc.

CIRCLE 175 ON READER CARD

price differential can now buy a workstation. Software development can now support their activity in a much larger, networked environment using lower-cost workstations."

The workstation market moves quickly, and new trends will

Individuals who really wanted a workstation but felt they had to go with a PC because of a perceived price differential, can now buy a workstation.

move capabilities and pricing in the months ahead. At some point, high-resolution displays are expected to drop in price, as more systems use them and they become more of a commodity. This may allow some price cutting on systems, but this will be at least partially offset by the higher memory requirements of these systems.

New processors will change functionality and performance as they come to market, but are unlikely to have dramatic effects on prices. The higher performance of the Motorola 68040 and Intel 80486 processors will be much faster, but developers will incur added costs in meeting system requirements for supporting these processors with faster memory, graphics and disc access, notes Weinberger. "The benefits will be in performance, not price," he says, adding with a laugh that HP/Apollo will be happy to get the additional performance. "But you won't see entry-level prices come down much, if any."

Rising Expectations vs. Price

WEINBERGER NOTES THAT WHILE COMPUTER manufacturers struggle to use technology to reduce product prices, they run smack into obstacles in the form of customer desires. "One of the things that does not get much attention is that, just as technology is improving, the expectation of what a workstation must do is increasing very rapidly. We have to keep increasing the capabilities constantly just to be seen as a competitor in this market."

Weinberger claims increasing expectations for UNIX operating systems. Minimum memory requirements are directly tied to the requirements of the software that will run on the system. Memory prices have come down considerably, but manufacturers have to include more of it to keep up with demand. These factors, he says, are responsible for recent increases in workstation products prior to the introduction of the DN2500.

At the root of this is the fact that processors, because they are dropping in price while workstations overall grow rapidly in functionality, are now a much smaller percentage of the total product cost. So providing a new price point in the DN2500 didn't necessitate any new processors, but rather a rethinking of the support systems in the workstation; a new strategy in how the other parts of the system come together.

The so-called X-terminals, expected to enter the market soon, are another example of reducing price by rethinking the product. The strategy is to reduce the price of the system by cutting it back to the least functionality that will support X-window server software, so most of the system support comes over the network. How low the prices for these systems can get, and how well the market will accept them remains to be seen. Weinberger notes that dropping prices even a few hundred dollars more will be attractive to some customers. He expects these products to be complementary to low-end workstations.

Low-end workstations will continue to change rapidly as competitors vie for market share, and the PC vs. workstation quandry continues. HP's now much broader family of products will continue to be in a strong position for that competition.

DIRTY TAPES?

Call or Send for
FREE Technical Guide



MAGNETIC TAPE CLEANER/REWINDER

PERIPHERALS

A High Technology Company

1363 Logan Ave.
Costa Mesa, CA 92626
Headquarters 714-540-4925
Outside CA 1-800-468-6888

CIRCLE 131 ON READER CARD

Would you like to continue to see articles on this topic?

Circle on reader card
yes 336 no 335

How to access an HP host in two easy steps:

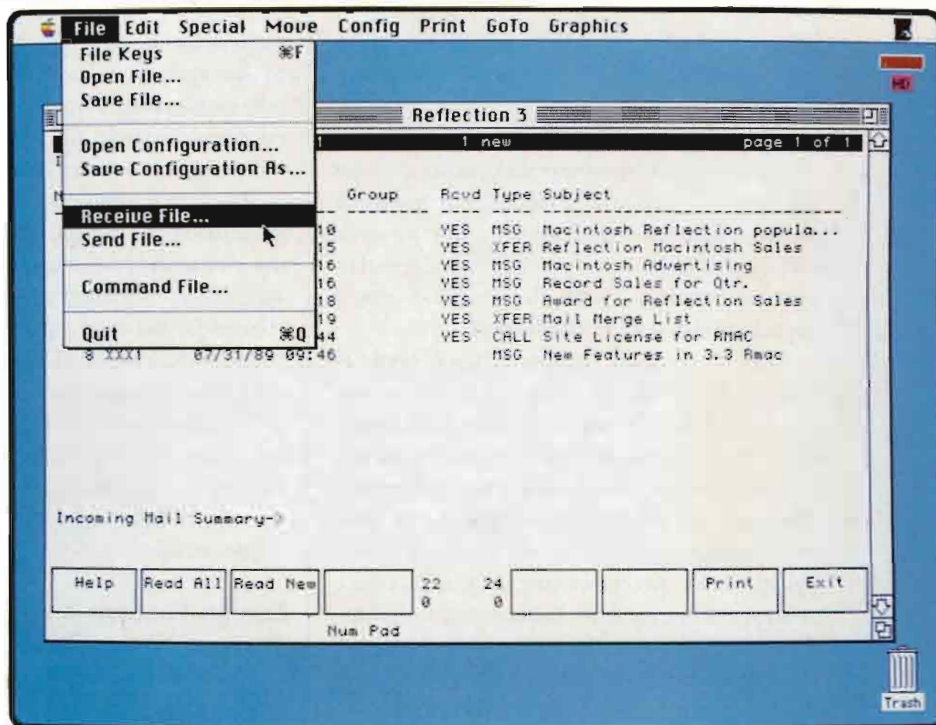

1. Point. 2. Click.

Combine the very best parts of an HP terminal and the Apple® Macintosh, and you get **Reflection® for the Macintosh**.

Reflection for the Macintosh turns your Mac into a full-featured HP terminal driven by the friendly Macintosh® interface. It's powered by the same quality features you're already familiar with in PC versions of Reflection. Now we've added context-sensitive help and a com-

plete Macintosh backup capability.

Whether you need graphics terminal emulation or just alphanumeric emulation, Reflection for the Macintosh provides an easy path to host data.

Call us today.

1-800-872-2829

Reflection 1 PLUS for the Macintosh: HP 2392A terminal emulation, MultiFinder support, command language, complete Macintosh to host backup, and file transfer to HP, VAX, and UNIX hosts. Just \$299* single copy price.

Reflection 3 PLUS for the Macintosh: Get HP 2393A graphics terminal emulation and all the features in Reflection 1 PLUS. \$399* single copy price.

DeskDirect: Works with Reflection to integrate your Macintosh with HPDesk-Manager, \$79* per Macintosh, \$500* per host.

REFLECTION
SERIES 3
SOFTWARE

Walker Richer & Quinn, Inc.

2825 Eastlake Avenue East Seattle, WA 98102
206-324-0350 FAX: 206-322-8151

REAL-TIME USER CONTROL



Application Control Library Utilities

Editor's Note: This article is the second-place winning entry in HP Professional's first Call For Papers Contest.

History doesn't record the first multiuser application, but I suspect it may have been a beast of burden.

This simple system was interrupt-driven (a stick helped), multipurpose and usually the user maintained complete control. As more and more of these multiuser systems came in contact at trail intersections, some protocol was needed to prevent collisions. With this in mind, you'll appreciate the system that follows.

Today's complex computer system applications can be as difficult to manage as the one just mentioned. It isn't unusual to have data transactions occurring on different computers relating to a common set of applications and master files. These are interrelated by direct access by users and managers and are maintained by master update batch processes that require absolute control during database backup and modification. If only there were a method for coordinating this discord by allowing users greater freedom to control one or more applications.

The hardware we use at HP's Avondale, PA Division is composed of several HP 3000 computers. They're connected in order to facilitate efficient use of user-maintained databases. The control design established in this paper doesn't require HP hardware. Descriptions will be kept as generic as possible.

Solving A Big Program

Two years ago, our MIS department determined that we had a big problem. We had interrelated applications that were separate and modified randomly, but daily, by well trained users. These users often were under time constraints that could take priority over a normal production maintenance "schedule." Access was through

terminals, direct to the data, using one or more application programs. I will refer to this as "session" access. These applications were processing on separate computers, linked through a network of data systems. Some applications require periodic mass maintenance to continue normal processing and uphold full user functionality. This will be referred to as "batch" jobs.

The batch jobs were of two types: (1) those scheduled to be done for regular processes and (2) those randomly introduced by users when some application milestone is reached. Methods and reasons for iterative application processes won't be discussed here. It's difficult enough to describe the interworkings of these systems, but when you add the last part of the problem — computer operators who don't have the time nor the training to play traffic cop — the situation borders on pathetic. The timing of transactions is unpredictable!

Design Factors

We needed a controller that would allow users to interrupt the normal processing, when necessary, and remain unshakable throughout all operation conditions. We also needed one that would alert all normal session or job requests to proceed as to the possibility to do so. Delivering the status of the application could provide users, operators and support analysts with knowledge about what the system logically would allow.

The design we arrived at consists of five distinct pieces.

- A one-record file that holds the logical state of the application.
- A program that, as directed by the user or job, will set the logical state.
- A file that contains a message for each logical state that is allowable for the application.



APPLICATIONS

Ted Lupien

- A program to read the state file, return the value of the state to the requester.
- A program that displays the message that matches the state value and also returns the same value as does piece four.

Simple But Effective Control And Coordination

We successfully have established the required user control of this dynamic environment. Each user selects the desired process from a set of user-defined commands (UDCs). The UDC allows the logical function desired, if the state of the application permits it. The user is informed of the state before any attempt at execution of the function. This provides valuable communication along with protection. Should the user need to override a current state, he has the ability to establish "application hold." This effectively puts all of that application's processes at rest.

No process can execute its contact with the application unless it first has gained access through the state verification. This prevents unsynchronized access such as the "weekly processing" without a "weekly backup." This will guarantee application routine maintenance, properly sequenced. It provides a measure of security, when inexperienced operators are at the system controls.

A programmer or analyst can enable "panic hold" of a specific application for repair or enhancement with no interruption of other application work. During panic hold, application users may remain logged into their session. At the same time, they're kept informed by messages either from the state message display or directly from a system manager or analyst. When all necessary panic-work is completed, the analyst resets the state and logical application processes resume.

Benefits

In each application there's a particular order that external transactions must use: backup, user access, archiving, purge/cleanup, other application access, etc. The designer of the system and the user/manager have particular rules and restrictions governing the type and order of transac-

tion. The application is controlled by a standard ASCII file, called a Control (or state) file. This allows concurrent access for both batch and session mode. This Control file is created and maintained by the SETSTATE program and is interrogated by the GETSTATE and SHOWSTAT programs. These programs and the Control file are described in detail later.

When users wish to control the application in normal production there are several ways to do so. Our design requires all users to enter the session through a "logon" which has a set of UDCs. These UDCs have a "check" UDC which uses the SHOWSTAT program to acquire the current control value and display its corresponding message on the screen. Every

Short on Ports?

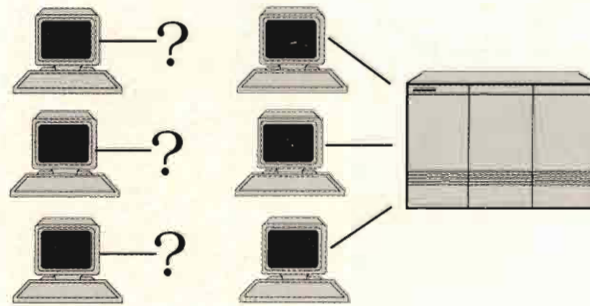

Get it together with Equinox

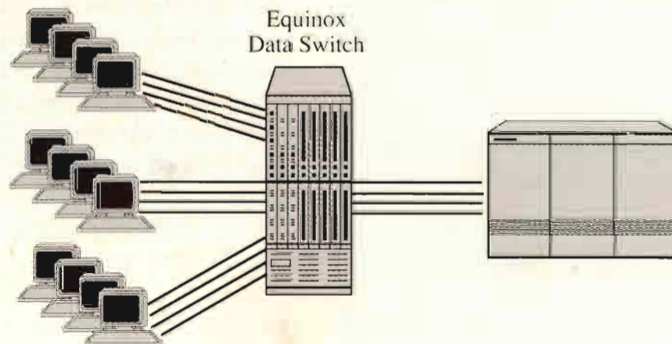

A low-cost Equinox data switch lets many part-time users share expensive CPU ports on demand. Share modems, solve multi-host access problems and network PCs too. All for a lot less than a LAN.

Call 1-800-328-2729

EQUINOX

Equinox Systems Inc, 14260 SW 119 Ave, Miami FL 33186, 305-255-3500

top rated by
datapro

IEEE-488...

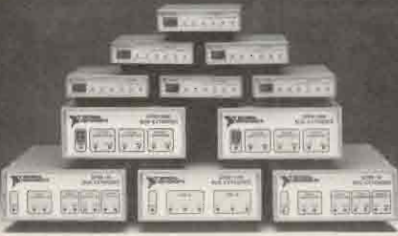

Converters and Controllers for RS-232, RS-422, Parallel, and SCSI

- Built-in 64K byte or 256K byte RAM buffer to spool data
- Controllers have onboard, programmable operating systems for standalone applications
- Switch selectable interface parameters
- Built-in DMA controller supports high speed transfers on the GPIB port (up to 900K bytes/sec)
- All-metal MicroGPIB™ case and connectors form a high impact shielded enclosure that minimizes EMI

Data Buffer

- 900K bytes/sec transfer rates
- 1M bytes of RAM

Extenders/Expander

- High performance parallel bus extender
 - Supports 28 devices at 300 m
 - 222K bytes/sec transfer rates
- Serial bus extender
 - Fiber optic or coaxial cabling
 - 144K bytes/sec transfer rates
- Bus expander
 - Optically isolates 2 GPIB buses
 - Extends GPIB by interfacing up to 14 more devices
 - Doubles the GPIB 20 m cable limit
 - Transparent to user software

- *FREE Customer support*
- *30-day money back guarantee*
- *2 year warranty*



12109 Technology Blvd.
Austin, Texas 78727-6204
(512) 250-9119
(800) 531-4742 U.S.
(800) IEEE-488 in Texas

Japan 81 (03) 788-1921 • France (1) 48 65 33 70
United Kingdom 44-01-549-3444 • West Germany 49 89 807 081
Italy 39-2-98491071-2-3 • The Netherlands 31 070-996360

Call for FREE catalog

CIRCLE 149 ON READER CARD

FIGURE

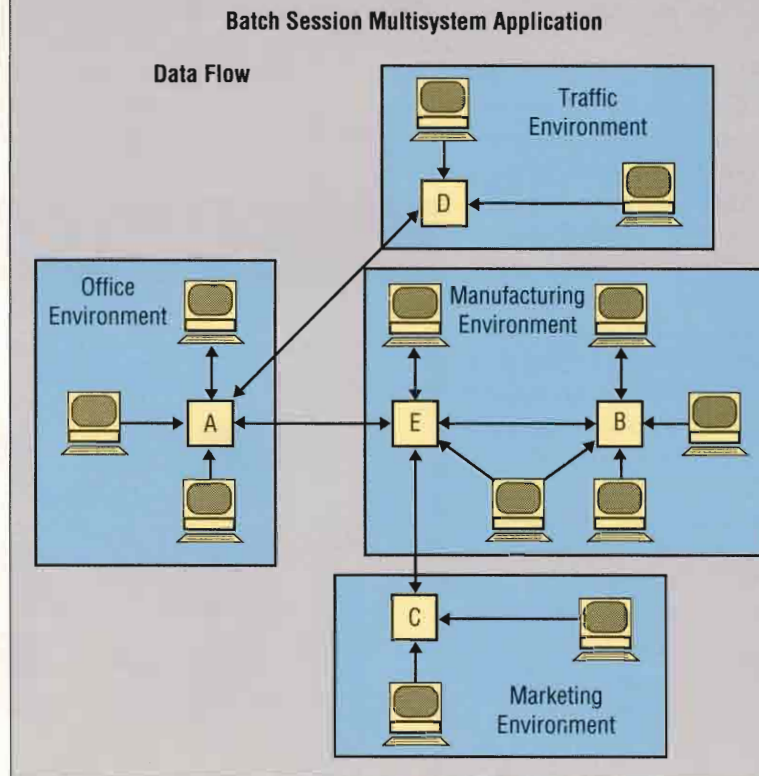

General state definitions.

user function that relates to the application must be accessed through a corresponding UDC. That UDC first calls "check" to verify that the process the user is requesting doesn't conflict with other processes. The SHOWSTAT value returned by "check" calls enables "check" to set a job control word (JCW). This JCW then may be used to allow or prohibit further action.

Special Or Emergency Interrupt

Occasionally a situation arises when a user must override normal production of batch/session work. Using the simple data flow in Figure 1, the scenario could be as follows:

The manufacturing computer work consists of applications "A" through "E." Applications "B" and "C" both update "E", and transactions from "D" and "E" are needed to complete daily work on

"A." The users of "A" are office clerks and managers. They can only work overtime if the general manager gives prior approval. Evening batch processing will complete only if there are no unresolved transactions in the database.

Today is closing day for application "A." The user daily work couldn't be completed before quitting time. Normally, batch jobs add new data transactions to the database, which require user verification to complete properly. The batch jobs are run after two other applications complete their batch processing. Usually this occurs between 9 p.m. and 10:30 p.m. each day. This is done so that those applications can be backed up before the third shift starts. The user/manager can place application "A" in a "hold" state, using his UDC called "HOLDIT." The batch transfer jobs won't move trans-

actions during the evening processing because they have GETSTATE program logic requiring them to append the transactions to a file that can be moved to "A" as needed. When the day crew for "A" arrives in the morning, their work will be uninterrupted. When each worker logs on, a check message will be displayed:

USER HOLD IN EFFECT. REMOVE USING THE PROPER COMMAND. OR IF YOU ARE NOT AUTHORIZED. SEE YOUR DEPARTMENT MANAGER. HAVE A NICE DAY.

A user/manager will logon and enter a UDC "FREEME" to reset the "A" state, so that the user sessions may proceed.

This last example gives the reader the basic idea of the ways information is readily available to users and managers who may not be there when a decision is made to stop normal processing. The example shows use of GETSTATE logic for batch jobs. If absolute status is desired to determine the state during batch job execution, the GETSTATE JCW could be displayed in the standard list. If the standard list is to be reviewed, it's desirable to use SHOWSTAT in the batch jobs also. The SHOWSTAT program will set a JCW, used for internal job control, as well as display a state message. This method of message communication, as well as setting JCW, lends itself to effective control across system boundaries. The state of a system always is available in message form to machine operators. Using this system, we have reduced the need for operator/user communication. Both operator and user are freed to concentrate on their major tasks.

Job Sequencing Assured

The careful design of the state logic, implemented in each of the batch jobs, will assure proper job sequencing. This means that periodic jobs (hourly, daily, weekly, monthly, etc.) will not be run out of sequence. Backup and recovery orders may be fixed or customized. The more complex the recovery, in terms of job and/or user interaction, the greater the benefit from implementing state logic controls. This system isn't intended to be

used in situations where an application is simple, void of communication problems.

SETSTATE

This program tool is designed to coordinate messages that inform users of the system's status. It allows a designer to set a JCW to some numeric value, represent-

ing the current state of a logical system and set a Control file record to that same numeric value.

This program either uses a file equated to a permanent file or a direct reference to the file. If that file doesn't already exist, running SETSTATE will create a temporary file that must be saved if communication between SESSIONs and/or JOBS

Can't get there from here?

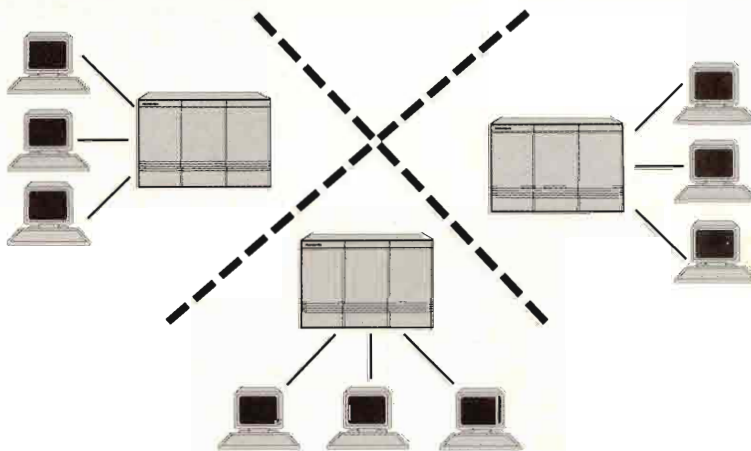

Get it together with Equinox

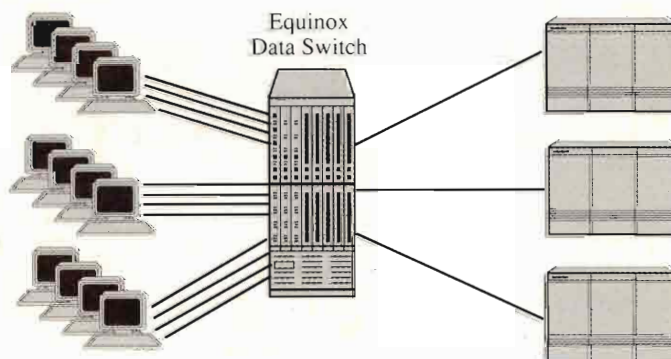

Eliminate access restrictions with a low-cost Equinox data switch. It lets users connect to their choice of host computers from their terminal or PC keyboard. Share computer ports, modems, printers and network PCs too.

Call 1-800-328-2729

EQUINOX

top-rated by
datapro

Equinox Systems Inc, 14260 SW 119 Ave, Miami FL 33186, 305-255-3500

is to proceed.

The general format for running SET-STATE follows:

```
RUN SETSTATE.group.account:  
INFO="jcwrd=nl:ctlfile"
```

The description for the "run" command items is found in *Table 1*.

If SETSTATE is unable to open the **ctlfile** file, the **jcwrd** is then set to the file error value of "10010". The designer should test for this state, at least during the application design phase. The **ctlfile** is opened in a "SHARED" state to enable reading of the state of the system.

Example:

```
:SHOWJCW  
JCW = 0  
CIERROR = 0  
:RUN SETSTATE.CONTRIB.SYS:  
INFO="MYJCW=150 STATE"  
:SAVE STATE  
:SHOWJCW  
JCW = 0  
CIERROR = 0  
MYJCW = 150  
:
```

SHOWSTAT

This program tool displays messages that inform users, operators and other system people of the current status of a system. It retrieves the numeric value from **ctlfile**, the **jcwrd** is set to that value, then a message is displayed from **msgfile**. The message is found using the numeric value

TABLE

Item	Description
group	the group in which the program file is residing.
account	the account in which the program file is residing.
jcwrd	the JCW of the designer's choice or the default "UTILITYJCW".
n	the numeric value that is to set, in the range [0 to 9999] default is 0.
ctlfile	file reference, for your key/jcw numeric value, default "UTLKFILE".
msgfile	file reference with the numeric referenced messages, default "UTLMFILE".
=	equal sign <i>must</i> be the only character between jcwrd and n.
[]	bracketed parameters indicate optional values.
;	semicolon is used as a delimiter, but blank or other special characters may be used (non-alphabetic, non-numeric such as the following; ~ _ > < / \ are ok).

Data flow for overriding normal production of batch/session work.

from **ctlfile**. For an example of such a file see the subsection MESSAGE FILE.

This program requires a file be equated to permanent files or direct reference to the files.

The general format for running SHOWSTAT is:

```
RUN SHOWSTAT.group.account:  
INFO="jcwrd:ctlfile:msgfile"
```

The description for the items in "run" commands is found in *Table 1*.

If SHOWSTAT isn't able to open the **ctlfile** file, the **jcwrd** will be set to the file error value of "10010". The user should test for this state. The **ctlfile** is

opened in a "SHARED" state to enable reading of the state of the system.

Example:

```
:SHOWJCW  
JCW = 0  
CIERROR = 0  
:RUN SHOWSTAT.CONTRIB.SYS:  
INFO="MYJCW STATE MSGFILE"
```

```
The ALPHA database is ready for USER work!  
(for help, call Charley B. or Linus V.P.)
```

```
END OF PROGRAM  
:SHOWJCW  
JCW = 0  
CIERROR = 0  
MYJCW = 150  
:
```

SIMPLY THE FINEST TAPE MEDIA DUPLICATION SYSTEMS AVAILABLE

CDS-3000 HEWLETT-PACKARD 1/4 Inch Cartridge Tape Duplicator

- 9144 and 9145 Compatible.
- Make up to 12 copies of a master tape simultaneously.

- Fast, accurate reproduction of H-P cartridge tapes is now easy.
- Copying is independent of tape format.
- Copy a full 67MB or 133MB tape in only 34 minutes or let us do your duplication for you. Call us for a quote.



DUPLICATION TECHNOLOGY

hp is a trademark of
Hewlett-Packard Co.

2830 Wilderness Place, Boulder, CO 80301 (303) 444-6157

CIRCLE 259 ON READER CARD

GETSTATE

This program tool retrieves the numeric value from **ctfile** and sets **keyword** to that value. This program requires a file be equated to permanent files or have direct reference to the files.

The general format for running GETSTATE is as follows:

```
RUN GETSTATE.group.account:
INFO="keyword:ctfile"
```

where the variables are defined as before, as are the options, default values and limitations.

Example:

```
:SHOWJCW
JCW = 0
CIERROR = 0
:RUN GETSTATE.CONTRIB.SYS:
INFO="GETJCW_STATEF"

END OF PROGRAM
:SHOWJCW
JCW = 0
CIERROR = 0
GETJCW = 150
:
```

Message File

The message file is an 80-character/record ASCII file created by an editor. It has the following record format: numeric identifier in columns 1-4 (in free format), a blank in column 5, and the remainder of the message in columns 6-80. The message creator is free to use any character or set of control/escape characters desired. The intent (result of display) is under the creator's control.

The creator must repeat the numeric identifier for each line of the message that's to be included in the display. The display of a message will stop when the numeric value changes.

Msgfile data accessed for the preceding examples of computer output follows in *Program 1*.

Control File

The design of the Control file is established for maximum flexibility. It's a one-record ASCII file. The file always is "opened, shared." There is an unsigned, ASCII numeric value in the first five character positions. The numeric value is

maintained by the SETSTATE program. Unusual or investigative conditions may require the analyst to use an editor to look directly at the contents of this file. Care should be taken not to corrupt the value. This would be the case if a undefined numeric value (for the application) or a non-numeric set of characters is placed in the record.

If this value becomes corrupted there

are two ways to correct the problem. The recommended method is to remove the file then recreate it using the SETSTATE program to initialize it. This has the advantage that the state record always will have a proper numeric ASCII value. Of course, there is the possibility that the value may be logically incompatible with the design of the application. Determin-

Continued on page 91.

All patched up?

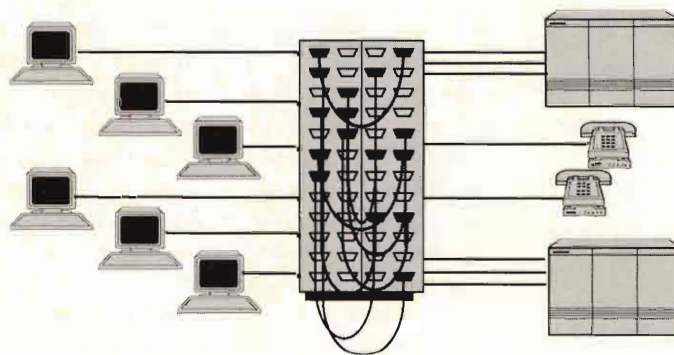

Get it together with Equinox

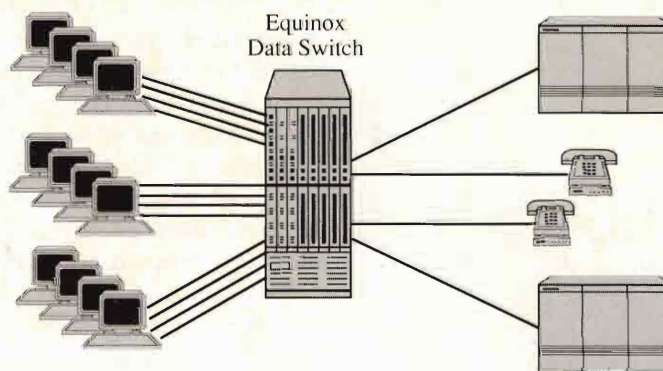

Prevent patch-panel panic. A low-cost Equinox data switch lets you easily control, monitor and diagnose your network from a terminal or PC. Switch to backup configurations, share CPU ports, network PCs and provide user initiated connections to hosts and peripherals.

Call 1-800-328-2729

EQUINOX

Equinox Systems Inc, 14260 SW 119 Ave, Miami FL 33186, 305-255-3500

top-rated by
datapro

C OOPERATIVE COMPUTING

HP & Apollo Look At A New Way Of Using Computer Resources

Even though the dust hasn't fully settled since HP began merging Apollo, one area of synergy is known. HP for a long time has been visionary in its approach to computing. This visionary approach has manifested itself in such products as the NewWave software for object management and the \$250 million R&D investment in Precision Architecture that gave HP one of the first complete lines of RISC machines in the industry.

Now, HP sees a bright future in creating a cooperative computing environment, or CCE, that permits computers (not only those manufactured by HP) to share processing demands and information freely across a network.

Realizing that Apollo offers not just stand-alone workstations, but powerful software tools and applications that span networks, such as the emerging standard for compute sharing known as the Network Computing System (NCS), the synergy between HP and Apollo becomes clearer.

Why HP's sudden interest in pursuing cooperative computing? In a presentation to HP R&D and marketing managers last January, Ira Goldstein, former R&D manager of the Technical Systems Sector who now is managing the R&D effort at the Open Software Foundation, says CCE is a great window of opportunity for HP. "While cooperative computing is an industry trend, it is still in its early stages," Goldstein says, "Consequently, a complete set of standards is not in place for all the relevant technologies. For example, while there are networking standards for the lower transport levels, there is still room for innovation at the higher levels. There is no industry standard yet for distributed operating systems or databases.

This opens an important opportunity for HP to set standards," Goldstein adds.

CCE Explained

CCE has yet to come under any formal or industry accepted definition. Books and papers have been published on this topic, but each author's definition varies to some degree on specific characteristics of such an environment. At his presentation, Goldstein offered the following definition: "A Cooperative Computing Environment is a set of computers that behave as a single integrated environment."

Because models of CCE aren't as much a technological breakthrough as they are a new way of using computing resources, it might help to look back at earlier methods of use. Goldstein explains it this way: "Timesharing, an older paradigm, offered the advantage of good communication between users of the system and economic employment of resources. Personal computing has established itself by emphasizing the quality of the user interface and providing a guaranteed performance for interactive services. Cooperative computing has evolved from the combination of the two technologies on modern networks. The personal computer has become the user node on the network, continuing to offer its advantage of quality interface and guaranteed performance. The time-shared system has become the server, offering its more expensive capabilities in a shared and economic manner to nodes on the network. The price for this useful marriage is the necessity for a software technology that can tie these nodes together in an integrated manner."

To see the evolution of CCE in another light, Goldstein made this interesting analogy: "In reflecting on the history of computing, it is amusing, and possibly illuminating, to think of CCE evolving from single computers in a manner



RESOURCES

Mike Carl

How Kelly unleashes HP performance.

It's a Kelly tradition. Taking HP system performance to the maximum. Cutting through the restrictions. Overcoming the limitations — whether posed by CPU, memory or I/O.

We've worked at it. Putting together solid HP system expertise — hardware, software and applications. Developing the tools. Delivering on promises. Establishing ourselves as "the HP performance people."

Who else would be first to ship *add-in memory for the new Spectrum-class systems?* 16-MB modules that get the best from that memory-hungry RISC-based HP Precision Architecture (HPPA). They're the first of various performance-boosting Spectrum-class products you can expect from Kelly.

And take our "classic" HP 3000

memory upgrades. The fastest available. With more board configurations than you'll find anywhere — from 1 to 16 MB. There's

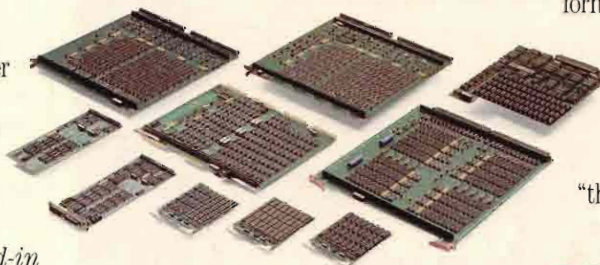

Kelly offers a broader line of HP-compatible memory products than anyone, including HP.

also our *XL/3000 RAMDISC* — up to 112 MB of plug-in solid-state disc — that boosts application productivity as much as 50%. Instant reads. Instant writes. With no added MPE overhead. And here again,

there's more to come.

A final point. When a Kelly product is ready, it's ready. Count on delivery. Performance. And reliability — attested by MTBFs exceeding 60 years, 20,000 units in the field and our Lifetime Memory Warranty.

Write, phone or FAX today. Learn more about how we've become "the HP performance people."

KELLY
COMPUTER SYSTEMS

1101 San Antonio Road
Mountain View, CA 94043
415/960-1010
Telex: 4931648 KELLY UI
Fax: 415/960-3474

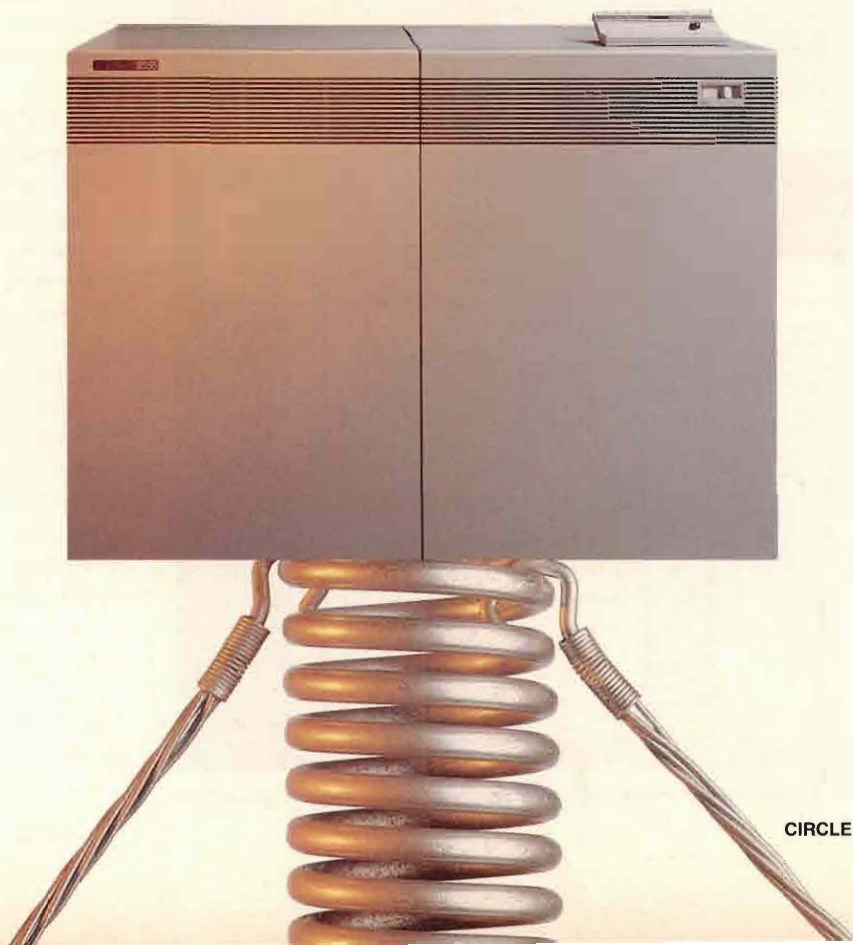

CIRCLE 173 ON READER CARD

FIGURE 1

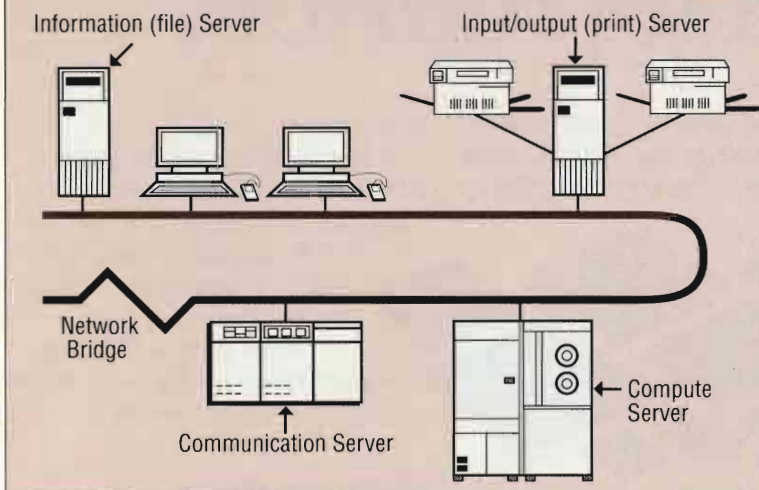

Layout of different servers in a Cooperative Computing Environment.

FIGURE 2

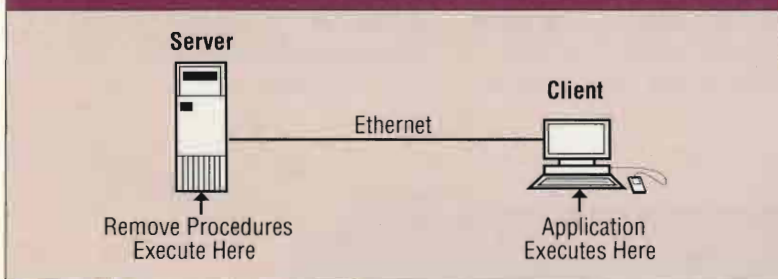

Client/Server Model in NCS.

FIGURE 3

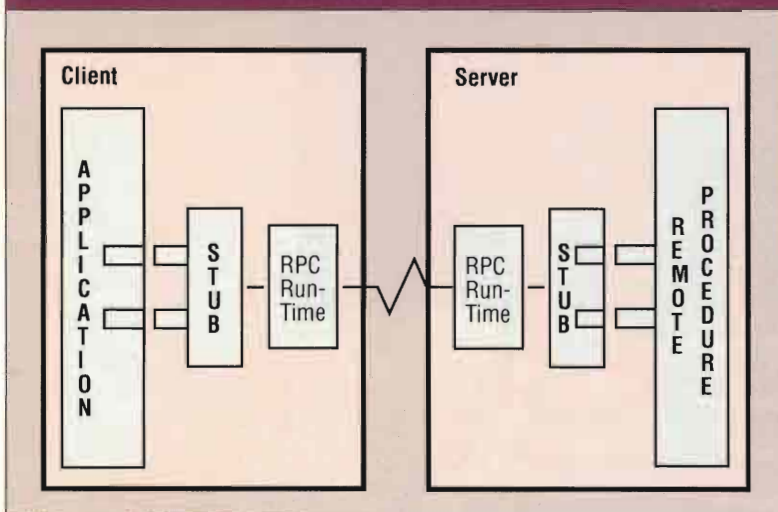

Relationship among software modules in an NCS application.

analogous to the evolution of multicelled creatures from their single-celled forefathers. In both cases, improved functionality is obtained by specializing — for a CCE of nodes on the network, for a multicelled creature, for its various cells. The network fulfills a role similar to the circulatory and nervous system of a multicelled animal,” Goldstein says.

Servers Within A CCE

If the network is indeed analogous to the circulatory and nervous systems, servers would act as the heart and brain in those respective systems.

Servers are included in networks to provide service to other processes on the network. For example, a file server installed on a network with three diskless workstations provides data access and storage to a user on any one of the workstations. This example is a popular implementation within a network or cluster of either HP or Apollo workstations. Without fast and reliable server-class machines to handle system-wide chores, such as supplying nodes with data files or compute time, HP’s vision of CCE would be a pipe dream.

An example of CCE could be managing financial data at an investment firm. An HP 9000 Model 850 would maintain a database covering every Fortune 500 company’s assets, liabilities and other fundamental data. A second 850 would contain technical data such as a running history of the company’s stock price and P/E ratio, while an HP Model 370 workstation would read and store real-time stock quotes as they come in over the wire. The stock brokers could request information and services from the servers, and display the results using charting applications running on their workstations.

Servers typically provide a smaller range of functions than most computers. According to the function provided, servers are divided into four categories: input/output, computation, information and communication (see Figure 1). Input/output servers control devices such as printers. Computation servers accelerate execution for programs that typically run

slow and place a large burden on the host computer. An impressive compute server is the Apollo Series 10000.

"As a compute server, the 10000 lets you set up a problem on some other machine in the network, then transfer the problem to the 10000, which solves the problem," says Paul Bemis, marketing manager for Apollo's high-end products. "It is a heterogeneous world, whether you like it or not. The niche for the 10000 is to provide high-performance resources across the network."

An example of an information server could be the file server mentioned above, while a communication server links nodes within a specific network, or bridges two larger networked systems.

The development of servers is crucial to a cooperative computing environment because they represent the essential building-blocks in such an environment. The server, a computing system component, gives the user the ability to add servers to meet increased system load, to place the servers anywhere on the network, to use multiple servers for increased security and up-time, and to meet tight budgets and performance requirements. As Goldstein says, servers are "CCE components that allow users to balance their networks in new and economical ways."

Simply plugging an Ethernet cable into the backplane of a server-class machine doesn't guarantee your network new vitality. To begin with, the new server creates increased system administration (i.e., configuring the thing into the network, backing-up its disc). Most importantly, the network will need software that takes advantage of the server in a distributed manner.

The foundation underneath a distributed client/server model is an Ethernet network, the TCP/IP communications protocol, and a piece of distributed processing software. The industry-standard piece of software that permits transparent access to files across a network is Sun's Network File System (NFS), which is supported by both HP and Apollo.

In addition to file sharing, compute sharing can be at least as important in a

distributed processing network similar to the one at the hypothetical investment firm. The increasing standard here is Apollo's NCS, which manages compute time among available networking processors.

Overview Of NCS

The three major pieces of Apollo's NCS software product are:

- The Remote Procedure Calls (RPC) run-time environment.
- The Network Interface Definition Language (NIDL) compiler.
- The Location Broker.

The NCS RPC is designed for vendor portability. The source code for the RPC run-time environment is written in C, and uses Berkeley sockets for inter-process communication. RPC, however, extends the socket methodology through a user-mode subroutine library that the RPC run-time code can access. This library compensates for different networking protocols and operating systems.

NIDL is a very high-level language that lets the application programmer describe all the remote procedures. These procedures are called by the client application with the numbers and types of their arguments. The description language is later compiled into C-language "stubs" that bind the application with remote procedures with the RPC run-time environment.

Finally, the Location Broker is a run-time software module that dynamically picks eligible servers on the network to execute remote procedures. Servers must first register their capabilities with the Location Broker. When the application executes, it queries the Location Broker to determine which server to use for a particular remote procedure.

With NCS, the programmer must think of the application in a client/server model. A simple implementation would have the application execute on the client while making calls to remote procedures that any eligible server could execute on behalf of the client (see *Figure 2*). In development of the NCS application, the programmer starts with a high-level description of the routines to be processed

BUY • SELL • MAINTENANCE

HP1000 HP3000 HP9000 HP Compatibles

World Class Service



World Class Savings

- SYSTEMS
- DISC DRIVES
- TERMINALS
- MEMORY
- I/O EXPANSION
- PRINTERS
- PLOTTERS

LARGE INVENTORY
GUARANTEED MAINTENANCE
BEST PRICES

COMPUTECH
SYSTEMS CORPORATION

2721 152nd Ave. N.E.
Redmond, WA 98052

(206) 883-4107
1-800-882-0201 (US)
FAX: (206) 881-2482

THE PATCH FOR ASYNCHRONOUS NETWORKS.

The Telamon Async Network Engine.

THE ONLY WAY OUT.

To electronic mail and database services. To X.25 PADs. To virtually any other system, for terminal passthrough and file transfer with Digital*, IBM* and the rest.

EASY ACCESS TO DIAL-UP SYSTEMS.

For PC and terminal users. For batch programs. Create fast, automatic routines for everything from dial-up to logoff. Integrate easily into existing HP 3000 applications, too.

LOW-COST HP 3000 NETWORKING.

When daily updates or remote accesses don't require full NS capability, let one Async Engine serve your entire network, and save tens—if not hundreds—of thousands.

HP 3000



OUTSIDE
WORLD

HP 3000



HP 3000

HP 3000

HP 3000



THE PATCH FOR BISYNCHRONOUS NETWORKS.

remotely. The NIDL compiler generates C source code for the necessary server and client stubs. These stubs are then linked with the application and RPC run-time (see Figure 3), allowing network-based applications to use remote procedures in a transparent manner.

Apollo's rich offering of distributed software products doesn't stop with NCS. In fact, Apollo sells software that allows a network of users to access a limited set of licenses for a product on a first-come first-served basis, a network of discs to be backed-up from a single point, and a user to perform an online search and retrieval from heterogeneous databases on a network.

Apollo's Networked License System, which uses NCS networking protocol, is a service that provides users of a network as many concurrent accesses to a software application as there are licenses for the application. If a license is available, the

application is loaded on the target machine. The NLS can be thought of as a librarian that checks out the product licenses on a first-come, first-served basis.

The NLS enforces the concept of cooperative computing by providing a network-wide mechanism to manage software licenses. Without this distributed license model, software vendors would be forced to license their software on a CPU-locked or site-wide basis only. This inhibits cooperative computing by restricting users free access to applications across various systems.

File Maintenance

Another area that represents a challenge when several computers are shared over a network is file maintenance. As computers and their files become more distributed over a network, it becomes harder for the system administrator to backup those files. It's ideal to have a backup system run from any machine on the network, backing up and restoring

files from any disc on the network, using storage devices located anywhere on the network. It's this philosophy that led Apollo to develop Omniback.

Because Apollo designed Omniback to execute in a distributed fashion on a network consisting of a variety of hardware from different vendors, it employs the NCS protocol. Omniback's modular design lets the backup (restore) be controlled from a single machine on the network, while the files are read (written) from (to) any disc to (from) any backup device. The three basic programs that make this design possible are the Operator Interface, the Disk Agent and the Media Agent.

The Operator Interface acts on the part of the system administrator to specify how and when the backup or restore is to be executed on the network. The Disk Agent manages the reading and writing

The Telamon Bisync Network Engine.

RUNS NOW ON HPPA.

For RJE 2780/3780 file transfer. 3780 transaction processing. Programmatic control of 3270-compatible device networks. And programmatic interaction with 3270 mainframe applications.

BENEFITS FOR CLASSIC HP 3000 OWNERS TOO.

Save 50% or more—and get more efficient 2780/3780 file transfer and faster 3780 transactions. Plus, dramatic savings for both host and device communications if programmatic access meets your 3270 solution needs.

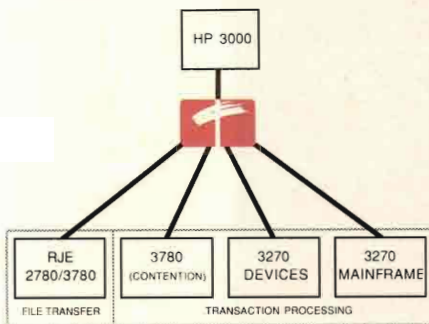

A PATCH FOR EVERY PURPOSE.



The Telamon Engine Family.

The Async and Bisync Engines are just two of the many useful, flexible tools in Telamon's versatile Patch Kit.

WHAT'S A PATCH?

Telamon patches are easy-to-implement, permanent solutions that make connecting your HP 3000 to the outside world easy.

So you can automate supervision of unattended systems. Control remote credit card verification terminals. You name it.

CALL 800-622-0630

Call the Solution Center, and we'll patch you right through. In California, 916-622-0630.

Fax 916-622-0738.

Or Easylink
6254-9890.

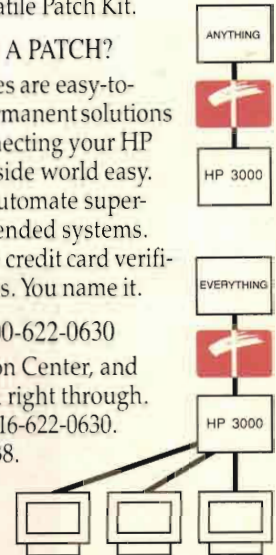

492 Ninth Street, Oakland, CA 94607-4098

CIRCLE 155 ON READER CARD

of files from the disc and to the disc. The Media Agent manages the backup to and restore from either magnetic tape, disc or 8-mm cassette tape. With this implementation, the Operator Interface can execute on a separate system from the Disk Agent and Media Agent allowing setup and control to execute in parallel with the writing of data to the backup media. In this way, data writing is almost continually running for maximum performance.

Using a similar design philosophy to that of NLS and Omniback, Apollo's Knowledge Broker is also built on top of NCS. Knowledge Broker provides on-line search and retrieval of information that can be highly distributed and formatted in a variety of styles. One situation where Knowledge Broker could prove useful might be the following.

Let's say a computer manufacturer has an engineering team who used Framemaker (a powerful WYSIWYG word

processor) to develop a product specification. From that specification, this manufacturer's publication group will write a user manual on Interleaf (another powerful WYSIWYG word processor). Both groups are connected on a LAN, but each group uses a different server to do their word processing.

Having installed Knowledge Broker on network, the publication group can view the product specification on line, search it, or copy pieces of the specification into the user manual. When the publication group completes a draft of the user manual, the engineers can review this draft on line, write comments about the draft in a Framemaker document, and link this Framemaker document to the Interleaf user manual.

With good reason, HP sees cooperative computing as an efficient and effective method of computing, and Apollo as a pioneer and leader in this area with products such as NCS, NLS, Omniback, and Knowledge Broker.

HP Executive Vice President, Lew Platt, summed it up best when he said, "If you take a look at the strong suits each party brings to the table, you'll see we have the combined products and technologies that should enable us to widen our lead. Apollo brings leadership in workgroup computing with NCS and computer-aided software engineering (CASE) products for large distributed applications. HP brings Native Language Support, NewWave's object-management facility and integrated programming environments for software development. Together, we will have a leading software development platform for distributed applications."

—Mike Carl is a learning products engineer for HP's Workstation Group in Sunnyvale, CA.

Would you like to continue to see articles on this topic?
Circle on reader card
yes 342 no 341

VISIMAGE



Since personal computers first became available, programmers and users have sought to bring information from their minicomputers and mainframes down to their PCs. VISIMAGE does just that.

Developed by Cogelog, a veteran of the HP 3000 marketplace, VISIMAGE is an HP PLUS, user rated independent software product. It's distributed in North America by VITAL Soft, a Cogelog Co. subsidiary.

For review purposes, I ran the VISIMAGE PC and used the VISIMAGE 3000 terminal interface of the HP 3000 (host)

software. I have noted where the VISIMAGE PC software offers increased functionality over the terminal interface of the host software.

Features

VISIMAGE has all the standard features you would expect of a report writer — access to IMAGE databases, MPE flat files, KSAM and other file types; output to either your terminal or printer; sorting to any number of levels with subtotalling, counting, page breaks and other features; an optional data dictionary plus the abil-

JOEL MARTIN

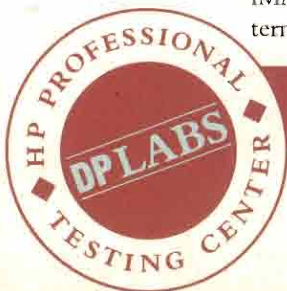



FULL SPECTRUM.

BackPack/XL

System backup on a 900 Series HP 3000 is a big job ... and with inevitable file expansion, it gets bigger all the time. BackPackTM/XL is a high-speed and unattended backup alternative that can keep backup chores under control. BackPack/XL runs over twice as fast as HP's TRANSPORT mode STORE, and faster than native mode as well. BackPack/XL also reduces tape use by half, and supports unattended backup. This approach reduces or eliminates user downtime.

BackPack/XL uses the same tape format as BackPack/V, so tapes created on a 900 Series HP 3000 can be restored on a stack system, and vice versa. HP's native mode STORE produces tapes which can't be restored on a stack HP 3000, and TRANSPORT mode, which produces compatible tapes, is very slow.

Use the system backup approach that's as dazzling as your new HP hardware. Call for your free demo today.

Tymlabs Corporation • Austin, Texas USA • (512) 478-0611 • Fax (512) 479-0735
Tymlabs-APPIC • Epiny sur Orge, France • 64-54-87-37 • Fax 69-34-03-23
Megatec Pty., Ltd. • Mitcham, Victoria, Australia • (03) 874-3633 • Fax (03) 873-5667
Processeg S.A. • Caracas, Venezuela • (582) 781-08-80 • Fax (582) 781-26-10
Quant Systems • Hoofddorp, The Netherlands • 2503-40334 • Fax 2503-39700

Tymlabs (UK) Ltd. • London, UK • 01-881-6644 • Fax 01-888-4087
Wink Hill Associates Ltd. • Egham, Surrey, UK • 0784-438441 • Fax 0784-433316
Infosistemas Financieras S.A. de C.V. • Mexico, D.F. • 254-3274 • Fax 254-7140
Posttronik GmbH • Essen, West Germany • 0201-237116 • Fax 0201-332707
Singapore Computer Systems Pte. Ltd. • Singapore • 775-2477 • Fax 778-2747

ity to use existing dictionaries created by HP's Dictionary/3000 or Cognos' PowerHouse; online or batch mode execution; user definable edit masks and formatting; online help; temporary variable definition; etc. What sets VISIMAGE apart from many other report writers is its visual interface (from both terminals and PCs) and smooth integration of HP 3000 and PC functionality.

You define reports in VISIMAGE through a series of screens (see Figures 1 and 2) rather than through a file of text commands. (My examples are from VIS-

What sets VISIMAGE apart from most other report writers is its visual interface... and smooth integration.

IMAGE 3000's terminal interface.) VISIMAGE PC offers all the features shown plus the added benefits of windowing and pull-down menus. Creating reports is

similar to the creation of formatted screens using HP's V/Plus software. The syntax used on some of the screens is also similar to the syntax used in HP's Query/3000 software. (Note the "H" for heading, "G1" for grouping, etc., at the left side of Figure 2.)

The combination of the two VISIMAGE products allows you to download "reports" of IMAGE and other data from the host HP 3000 into LOTUS 1-2-3, dBase III, MULTIPLAN, VISICALC and other PC file formats. To access your HP 3000 from a PC doesn't require a separate communications package. Terminal emulation and file transfer is made possible by a communications package built into VISIMAGE PC by Walker Richer & Quinn, makers of the Reflection line of terminal emulators.

The individual steps defined in a VISIMAGE report (selection, sort, etc.) can be saved in libraries as "building blocks" for later reports or for batch jobs. Successive refinement of selections is possible through use of this feature.

Other special features of VISIMAGE are its ability to integrate with OMNIDEX (the database search engine developed by Dynamic Information Systems Corp.), a tutorial mode to better assist novice users with report writing, a macro generation facility and a variety of graphics outputs.

Installation of VISIMAGE on both the HP 3000 and PC is straightforward. Running VISIMAGE doesn't require any further setup.

Test Impressions

I was able to breeze through both the PC and HP 3000 versions in very little time. The authors have struck just the right balance in conveying the ease of use and

Figures 1-2.

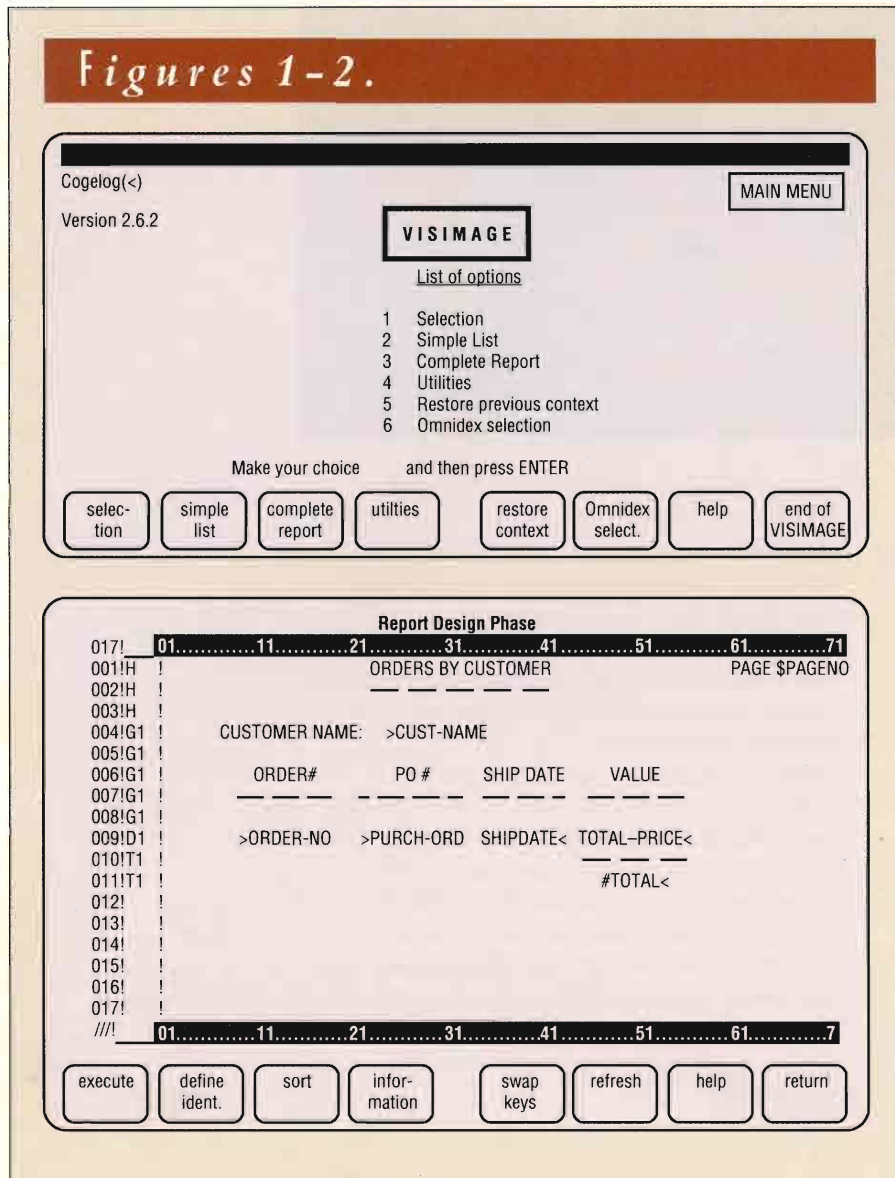

Defining reports in VISIMAGE is done through a series of screens.

WHY HEWLETT-PACKARD CHOSE OUR HIBACK™ AND DBTUNE™ SOFTWARE OVER EVERYONE ELSE'S.

We'd like to be modest, but it's impossible. Because after months of testing and evaluating all the alternative backup software available for their HP/3000, Hewlett-Packard chose ours exclusively. HP discovered, that we were the only HP backup product which allows store and restore over networks and unattended backup to disc. And now our HIBACK software is the only one of its kind completely in NATIVE MODE.

They rated our HIBACK/3000 product, Number One in: speed, security, error recovery, flexibility, data compression and in cost effectiveness.

Hewlett-Packard chose our DBTUNE/3000 and DBTUNE/XL database software for its outstanding preventive maintenance, capacity management, performance tuning, root file maintenance, hi-speed general database mainte-

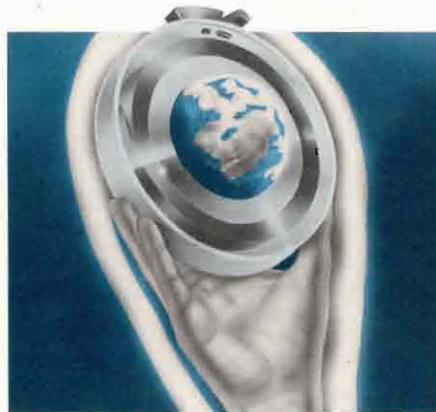

nance and because with all Hi-Comp software, they save time, money and provide peace of mind.

Hi-Comp is very proud that our backup and database management software has been chosen, not only by Hewlett-Packard, but continues to be chosen by many other international companies like BASF, Shell and Mobil. (But don't take our word for it, find out for yourself.)

If you would like more information regarding the strategic and financial impact our unique software can have within your company, call, fax, or write our New York or Hamburg office today. If you'd like,

we'll give you a free 45 day trial demo tape. We are known as "The Innovators," because we "back-up our backup" software with more exclusive features and financial savings than anyone else.

Hi-Comp Hinrichs GmbH,
Eichenlohweg 24, D-2000
Hamburg 60; Tel.: 49-40-630
4011; Fax: 49-40-631 6004.
Toll Free UK: 0800-898501.

FREE DEMO TAPE!

Call or send for a Free
45 day trial demo tape!

H · I · C ·  · M · P
AMERICA, INC.

"THE INNOVATORS"™

Hi-Comp America, Inc.
305 Broadway, New York, NY 10007
212 732-1946 212 233-4678 fax
1-800-DBETUNE Toll Free

- Please send me more information about your HIBACK and DBTUNE software.
- Please send me your **FREE** 45 day trial demo tape:
- Hiback DBTune MPE-XL MPE-V

Name: _____

Company: _____

Address: _____

City/State: _____ ZIP: _____

Phone: _____ Fax: _____

CALL TOLL FREE 1-800-DBETUNE

power of VISIMAGE without creating a series of burdensome exercises. I particularly liked the "information" facility — if at any point you have forgotten the spelling of a data set or data item you can display a list of the accessible ones in a scrollable pop-up window. Defining field titles and edit masks is also easily done with VISIMAGE PC through the use of another pop-up window.

The windowing and pull-down menus of VISIMAGE PC are less work when contrasted to the VISIMAGE 3000 terminal facility on the HP host. A series of separate forms replaces the overlapping windows of the PC version and requires the traversing of a hierarchy of screens. Having access to only eight function keys (an MPE and terminal limit) and doing without the pull-down menus of the PC version may make the terminal user feel that the visual interface, so natural on the PC, is of little advantage when applied to report writing on the HP 3000.

Using VISIMAGE on my test database took more work than I expected.

Before accessing your own data you must define the work environment

VISIMAGE 3000 and VISIMAGE PC

SYSTEM REQUIREMENTS: For VISIMAGE 3000 — any HP 3000 CPU. For VISIMAGE PC — HP Vectra PC or IBM PC compatible, 512k of RAM, MS-DOS Version 3.0 or later (3.2 for the IBM Convertible).

PRICE: VISIMAGE 3000 — \$4,000 (Micro 3000) to \$11,500 (Series 950). VISIMAGE PC (includes VISIMAGE 3000) — \$4,745 (Micro 3000 plus PC copies) to \$13,740 (Series 950 plus 10 PC copies). Demonstration tape and PC disc — \$100.

VITAL Soft

HEADQUARTERS:

1916 Old Middlefield Way, Suite E
Mountain View, CA 94043 (415) 965-4494
(800) VITALSOFT (from outside California)

FOUNDED: 1986 as a division of Cogelog

PRODUCT LINE: VISIMAGE

CIRCLE 284 ON READER CARD

Figures 3.

Illegal data item or field name SELL-PRICE QUANTITY Line 10

Definition of Identifier Phase

015!	01.....11.....21.....31.....41.....51.....61.....71
001!D	!C1:#BAL>0
002!G1	!#cnt = 0
003!D	!#cnt = #cnt + 1
004!G1	!#tot-price = 0
005!D	!#tot-price = #tot-price + buy-price
006!T1	!#avg-price "zzz.zz9.99" = #tot-price / #cnt
007!T1	!#cost "zzz.zz9.99" = #avg-price * quantity
008!D	!sell-price "zzz.zz9.99"
009!G2	!#bal "zzz.zz9.99" = 0
010!T1	!#BAL=#bal + (sell-price * quantity) - #cost
011!T2	!c12:#BAL>0
012!D	!ORDER-no
013!D	!ORDER-date
014!D	!PROD-desc
015!D	!QUANTITY
!!!	01.....11.....21.....31.....41.....51.....61.....7

execute back to design sort information swap keys refresh help return

Creating identifier definitions for grouping, counting and averaging.

through a "manager" or configuration file. (The environment is the set of databases and other files that are available for access.)

Following the steps defined in chapter two of the "Administrative Overview," a separate document that covers manager files, dictionaries and two other topics not addressed in the user manual, I attempted to load the optional VISIMAGE dictionary with information from my Cognos PowerHouse dictionary. All seemed to go well, though I received a few warnings and a cryptic "Invalid access code" message at the conclusion of the process. When I attempted to access my own data with VISIMAGE, I was able to view the data sets but not the data items within them. A call to technical support confirmed that my PowerHouse data was lost when the data sets were converted to VISIMAGE. I was able to remedy the problem by generating the VISIMAGE dictionary directly from my IMAGE database according to the process described in chapter two.

Defining sort criteria is very straightforward, as is laying out a report. Using VISIMAGE gets less intuitive when it

comes time to create identifier definitions for grouping, counting and averaging (see Figure 3).

Links between two or more datasets can be handled automatically based on the IMAGE defined paths, and data item names or explicit links can be defined (even named) in the configuration files noted earlier. Creation of record complexes is straightforward using this link facility and a related facility for restricting chained reads to the first entry in the chain (if desired).

Calculations and reformatting of data that are complex or span more than one report can be defined in a macro and called by any user whose configuration file references the macro file containing the operation.

My overall impression is that developing reports on a visual platform (the PC) with VISIMAGE PC is a treat, but that the lack of windowing and pull-down menus handicaps the terminal facility of VISIMAGE 3000.

Documentation

The VISIMAGE documentation is well written and well presented but too brief. There's a 100-page spiral bound user

The visual interface of VISIMAGE makes the creation of simple but attractive reports quite easy. Very complex reports are also possible with VISIMAGE.

manual and a 33-page administrative overview. The administrative overview is four separate documents, one for each chapter, covering the creation of MANAGER files (also known as "Visimmgr" or configuration files), dictionaries, linking and macros. Each chapter is a small collection of pages stapled together.

The manual is sufficient to perform lesser tasks. But when it comes to performing advanced work, there could be better coverage. Facilities that are fairly well documented in the VIS-IMAGE PC manual (e.g., conditional tests and temporary variables) receive little if any treatment in the VISIMAGE 3000 manual.

The manual for VISIMAGE PC is well done but also too brief. It is attractively packaged in a half-size three-ring binder and is well complemented by a Quick Reference Guide. The manual treats

some product areas quite well (e.g., edit masks) but is a bit short with other functions. It could benefit from more graphics and the inclusion of some complex sample reports to better illustrate the product's power.

The user manuals for both VISIMAGE 3000 and VISIMAGE PC are well indexed and include a glossary of terms.

Technical Support & Support Policies

VITAL Soft provides a toll-free number for sales and support from outside California. Callers from inside California must use a local number. Technical support is available from 6:30 a.m. until 6 p.m. I called VITAL Soft when attempting to add my own database to the VIS-IMAGE configuration file. The woman who assisted me was very knowledgeable

and ably guided me through the initial steps.

Summary

The visual interface of VISIMAGE makes the creation of simple but attractive reports quite easy. Very complex reports with intermediate tables, user defined variables and sophisticated linkages are also possible with VISIMAGE. However, they may require a few more trial efforts than would be the case if the manuals were more complete. If you're interested in exploiting the advantages of a PC in developing reports and need data from your HP 3000 on a PC, consider VISIMAGE from VITAL Soft.

Dynamic Information Systems Corp.
910 Fifteenth St., Suite 640
Denver, CO 80202
CIRCLE 283 ON READER CARD

Cognos Corp.
2 Corporate Place, I-95
Peabody, MA 01960
CIRCLE 282 ON READER CARD

Walker Richer & Quinn
P.O. Box 31876
Seattle, WA 98103-1876
CIRCLE 281 ON READER CARD

Information Builders Inc.
HP Division 1250 Broadway
New York, NY 10001
CIRCLE 280 ON READER CARD

WORDWISE 300

Technical Word Processor

Spelling Corrector
Proportional Fonts
Terminal Emulator

Mailing List Data Base
Hi-Res. Color Graphics Printer

Easy to learn and use
with on-screen Greek, Math,
and Foreign characters

More than 3000 installations on
HP 9000 Series 200, 300, 520.
Now for Basic-UX & PC's with
HP's BLP card or HiTech Basic

Unsecured BASIC source code
No copy protection
MS-DOS, SRM & HFS support
All this & more for \$495

lot x vs. y data quickly

lot HPGL files* on the
CRT, 300 dpi on the
LaserJet, and in
color on the PaintJet

rint differences
between 2 files

rofile program line
execution times

rogram without line
misnumbering bugs

hone text transfer with
terminal emulator

erpetual calendar with
holidays

ascal, Basic & C/200, 300 & 800*

**Series 200/300
Utilities**

All this & more for \$195

Temple
DATATAP® GRAPHICS/ANALYSIS

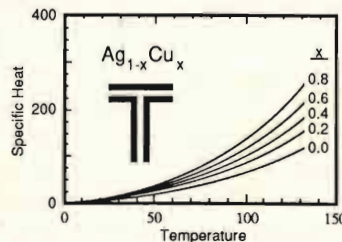

Your data
can look like
this in just a
few minutes!

Rectangular or Polar, Log or Linear axes. Flexible data input with optional error bars. Intelligent graphic defaults with nearly unlimited ability to easily modify all aspects of the graph. Each change you make to the data or the aesthetics of your graph is instantly reflected on-screen. Drawing, data transforms, functions, spline fits, insets, legends, linear and non-linear regression, statistical analysis, etc. Combines the best features of your visual analysis and the computer's mathematical analysis.

All this & more for \$990; Graphics subset \$299

FORTTRAN

↓ to

**BASIC
Translator**

★
Make the move from batch to
interactive, and watch your
productivity soar!

★
Automatically translates up to
99% of the code of a
Fortran program or
subroutine into HP BASIC.

★
Ask for a free copy of
Original Adventure
(translated from Fortran)
with all orders placed
before 12/31/89

All this & more for \$495

303-530-9014 Voice or Fax



James Associates



7329 Meadow Court, Boulder, CO 80301

CIRCLE 184 ON READER CARD

A Database For Sales, Customer Service And Marketing

Trigger Company Keyword HP 9000/500

(2) Hit List

Company	First Name	Last Name	Phone
AUTO FACTORY	FRANK	MANNON	404-455-3475
BUSINESS DECISIONS	KEN	BESSENGER	408-244-3669
CAL INVESTMENT	LAURENT	EVANS	1-212-825-5774
CAL INVESTMENT	DAVID	FISHMAN	(212) 825-6516
COMPUTER EQUIPMENT	LARRY	CLAIR	603-884-0887
COMPUTER SOURCE	TERRY	HRAB	404-952-0337
LEAD DATA CENTRAL	SUSAN	CANDY	513-865-1754
MONOGRAPHS	SHELDON	SMITH	1-617-658-5600
NORTH AMERICAN	RON	ZIMMER	219-429-3576
SPEAK CORPORATION	MICHAEL	POWRY	1-(404) 980-1616
WFS INC	LISA	KASTREL	617-499-2291

Use up and down arrows to navigate list, (Select) to select person to call
Char Mode: Replace Page 1 Count: #11

CallBack

CallBack from Abend Associates (Burlington, MA) is an interesting database application that addresses the needs of sales professionals — a segment of the market that can benefit from more use of computers, yet have limited commercial products available to them.

CallBack is based on the Oracle Relational Database Management System, which means it can be ported to any hardware and operating system where Oracle is available. CallBack will work not only on Vectras and MS-DOS systems, but also on HP 3000s and HP 9000/800 systems.

CallBack provides a unique forms-driven database application to allow you to retrieve customer or client entries from your system based on keywords as well as by name. Abend markets the product as a tool for sales professionals, but I think it could be of equal value to anyone who works with a large number of customers, clients or suppliers.

Getting Started

When I received CallBack, I was very impressed by the quality of the packaging. CallBack comes in a small binder that fits

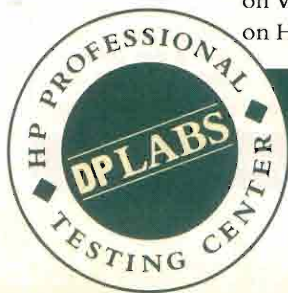

MILES B. KEHOE

EasyReporter™

the ultimate in end-user computing

Finally! Computer software that is genuinely designed for use by personnel outside the d.p. dept.

Your users can:

- write reports
- do on-line inquiry screens
- download results to PC's
- turn their reports into graphs

... all, without programming

... all, with your tight control of the system.

EasyReporter is a fine complement to your POWERHOUSE, SPEEDWARE or 3GL environment that your users will appreciate.

To find out more about EasyReporter, the ultimate end-user computing tool contact us at:

(416) 678-1841 Marketing Dept.
7420 Airport Road
Suite 201
Mississauga, Ontario
L4T 4E5

In Europe: London (01) 828-1897

Infocentre Corporation

infocentre

CIRCLE 172 ON READER CARD

A *t the heart of the CallBack Database is the ability to track long-term relationships and contacts.*

in nicely with all my other PC software.

The manual has a brief table of contents, but provides only section number references.

Installation

Note: These installation procedures are not applicable to systems larger than a PC (i.e., HP 3000).

The installation section is very well written and clear. The process runs automatically, and despite the fact it modified my CONFIG.SYS file, I found it more than acceptable.

Because it requires Oracle, you will find CallBack doesn't work on your PC unless you have at least 1.5 MB of main memory. The manual says you need 3.5 MB of disc as well, but I could not install CallBack until I had 6 MB free. CallBack requires MS-DOS 3.1 or greater but no special graphics adapter or other peripherals are needed.

The manual documents how to build a smaller database when disc space is limited; it seems that the user should be able to install the software regardless of available disc space to take advantage of this feature.

CallBack wasn't as picky about memory during the installation. The first system I installed CallBack on didn't have extended memory. Of course, it didn't take long before I realized CallBack required extended memory.

Once the CallBack installation completes, you're told to reboot your system so the modified CONFIG.SYS can take effect. As far as I can tell, the only change to my file was the added line "BREAK=ON"

to allow CTRL-C breaks. This directs MS-DOS to allow CTRL-C to interrupt even disc operations, which just highlights how important the suggested daily backups are.

The next step in installing CallBack is to execute the INITIALIZE procedure, which actually builds the CallBack database. At this stage, CallBack invokes Oracle and your disc space really gets eaten up. By the way, if you don't have enough extended memory, or if your memory isn't configured correctly, the initialization process prints a single line error message in a maze of text on the screen. I honestly didn't notice it the first time through, so I discovered how poorly CallBack detects and reports errors. The error message was from Oracle, but no error messages are provided in the troubleshooting section. I can only assume the error was related to memory size.

Once I got CallBack onto a system with enough memory, the database initialization went fine and completed normally. However, like the actual CallBack product, the initialization process ends by executing my AUTOEXEC.BAT. I presume this is to restore the PATH it had changed during its execution, but in MS-DOS this can be risky: I found myself with two copies of my mouse driver and every TSR I use, and with very little free memory!

Running CallBack

When you install CallBack, you provide a username and a password as part of the database initialization. To start the program, you enter the program name and the username and password.

At the heart of the CallBack Database is the ability to track long-term relationships and contacts. CallBack also provides a keyword matching function for clients and contacts. This can be very handy to help you keep track of your customer's interests. For example, a sales professional can search his CallBack database to help locate prospects for a new product.

However, the utility of CallBack is not limited to sales professionals. CallBack can be very useful to anyone who has a need to contact customers or clients regu-

CallBack

SYSTEM REQUIREMENTS: HP 3000/900, MPE XL, Oracle, 1.5MB of memory, MS-DOS 3.1 or greater. 3.5 MB of disc.

PRICE: Depends on system and number of users.

ABEND ASSOCIATES INC.

HEADQUARTERS:
265 Winin St.
Burlington, MA 01803
(617) 273-5383

FOUNDED: 1985

PRODUCT LINE: CallBack

CIRCLE 285 ON READER CARD

larly and who wants to create a "tickler" file for each contact.

CallBack uses several data entry screens to create entries for each customer contact. You can associate keywords with the customer. For example, noting one contact as a lead engineer and another as a purchasing manager. You also can note personal information on each contact so you can remember birthdays, anniversaries or hobbies.

In addition, CallBack lets you associate keywords with each contact you have with your customers. On one call, for example, you may want to note that a particular customer is interested in a product you can't yet sell but is going to be out in a few months. When your product is available, you can search your contact database to locate those customers who are most likely to buy your new product.

CallBack keeps track of when you contact each customer in your database. In fact, with the right telephone equipment, CallBack will even dial the phone for you! This helps you insure that you contact all of your customers or prospects regularly, not just when you think of them.

In addition to CallBack's standard screens and reports, you can customize the screens and forms using Oracle's SQL-Forms product. This allows you to provide forms that are more appropriate to your company if needed.

Overall, I found CallBack an accept-

able product to solve some of the problems professionals have in tracking their contacts with customers or clients. However, Abend Associates markets CallBack to people who aren't computer professionals, and I think there is room for an improved user interface.

Some of the odd key assignments are a function of the underlying Oracle code. Nonetheless, there are a number of menus and screens that contain cryptic codes and key names. For example, there are screens which refer to keys <Crerec>, <NxtGik> and <Exit>, that aren't named even on the quick reference card. By changing the screens to <Create Record>, <Next Block> and <Quit> the screens would not only match the quick reference card, they would also have additional meaning to the user and make CallBack "feel" more friendly.

Also, I'd like to see CallBack become less "modal." By this I mean that I'd like to be able to move from field to field more easily, and not have to be concerned whether I am in the "query" mode or the "new entry" mode.

CallBack also needs better documentation. Error messages for CallBack as well as for Oracle should be provided, along with likely solutions. The format of the help that is present is great. There needs to be more of it.

Still, if you have a lot of memory in your Vectra and want an application that will let you track your customers, clients, prospects and friends, CallBack may be just what you want.

Abend Associates new release of CallBack (Version 4.0) is in beta test and will be available this month. This is the first release using Oracle Forms 2.3. The changes include: Keyboard mapping improved to provide logical use of cursor keys, error messages now are controlled; (Oracle Forms 2.0 did not allow message control), restricted use of Oracle's "Query Mode" to eliminate confusion for users, and online help and all messages have been customized to refer to specific keys.

Why not the best?



**HP 1000,
HP 3000, &
HP 9000
150 Megabyte
& 2 Gigabyte
Streaming Tapes**
Unattended backup
of all your data on a
single ultra-compact
cartridge.
Media translation &
SSS update service
available

Also available:

HP 1000 Memory Expansion

Improves system performance. Free evaluation.
512 KB to 32 MB expandable cards. 2 year warranty

High Performance SCSI Interfaces for HP 1000, HP 3000, & HP 9000

Superior to IEEE-488. Used with all Herstal
Automation peripherals

HP 1000 & HP 9000 Disc Drives

65 MB to 638 MB. 30,000 hour MTBF.
Up to 7 drives per interface

HP 1000 & HP 9000 Optical Discs

1 Gigabyte Erasable and "Write Once". Ideal for
information retrieval and archival data storage

Ramdisc/1000 Speeds up file access

Superclock/1000 Automatic time & date



*"I promise you —
no service hassles, no
matter who is servicing
your HP system."*

Rick Walsh
President



HERSTAL

AUTOMATION LTD.

3171 West Twelve Mile Road
Berkley, Michigan, USA 48072
Telex 650-321-1560
FAX 313-548-2010
Phone 313-548-2001

CIRCLE 115 ON READER CARD

REPRINTS?

If you would like
reprints of any article or advertisement,
contact Reprint Resources,
155 Commerce Drive
Fort Washington, PA 19034
(215) 643-9143
FAX (215) 643-9164



RDBMS

Fabian Pascal

Error Proneness And Database Integrity

I recently came across some new information on missing values in

database management - a thorny issue. The new material has implications for all three data aspects (structure, integrity and manipulation). This alerted me to a couple inaccuracies in the previous columns covering integrity, which may not have been detected.

The sheer fact that it's relatively easy to miss them illustrates the point I was trying to make regarding the importance of central enforcement of integrity by the DBMS. I am digressing a bit, therefore, to correct them and to exploit their educational value.

You may have noticed that I used two slightly different versions of the project management database in the column. In the June column, the database consisted of four tables: DEPT, EMPLOYEE, PROJECT and ASSIGN. This version was used prior to covering integrity in the July and August columns and kept simpler for clarity.

To illustrate some of the integrity and manipulative features, I needed a slightly more sophisticated database. This is why

The sheer fact that it's relatively easy to miss inaccuracies illustrates the point I was trying to make regarding the importance of central enforcement of integrity by the DBMS.

I added two tables to the database used in the July, August and September columns. The new version had six tables. Four are the original tables with clearer names: DEPARTMENTS, EMPLOYEES, PROJECTS and ASSIGNMENTS. The two tables added are: ACTYPES (which records the types of work activities to be allocated to projects), and ACTIVITIES (which associates each project with its allocated activities).

Both examples are actually simplified versions of a database whose tables had more rows and columns than what was used for these articles. The second version has the complete table structure of the original database, but less rows and columns.

Considerable care had to be exercised

in simplifying the database. On the one hand, it was important to minimize the number of rows and columns in each table to keep examples as simple and as clear as possible. On the other hand, the database had to be sufficiently sophisticated to serve as a basis for all the relational features to be demonstrated. Moreover, when eliminating some of the data, I had to be careful not to cause any violations of the integrity rules pertinent to the database.

In discovering that my efforts to achieve that objective weren't completely successful, I couldn't help remembering the method of inserting intentional errors in teaching material to check if the students pay attention. I can't, of course, claim that I was as smart as that, but I am nevertheless tempted to ask: Has anybody noticed any

FIGURE 1.

EMP#	ENAME	DEPT#	HIRED	SALARY
100	Spenser	E21	6/19/80	26150
150	Adamson	D11	2/12/72	25280
160	Planka	D11	10/11/77	22250
310	Setright	E11	9/12/64	15900
250	Smith	D21	10/30/69	19180
260	Johnson	D21	9/11/75	17250

EMPLOYEES Table

DEPT#	DNAME	MGR#	RDEPT
A00	COMPUTER SVCS DIV.	10	
D01	DEV. CENTER		A00
D11	MFG. SYSTEMS	60	D01
D21	ADM. SYSTEMS	70	D01
E01	SUPPORT SVCS	50	A00
E11	OPERATIONS	90	E01
E21	SOFTWARE SUPPORT	100	E01

DEPARTMENTS Table

The RI Violation.

FIGURE 2.

DEPT#	DNAME	MGR#	RDEPT
A00	COMPUTER SVCS DIV.		
D01	DEV. CENTER		A00
D11	MFG. SYSTEMS	160	D01
D21	ADM. SYSTEMS		D01
E01	SUPPORT SVCS		A00
E11	OPERATIONS	310	E01
E21	SOFTWARE SUPPORT	100	E01

DEPARTMENTS Table

Revised DEPARTMENTS Table.

TOOLS TOOLS



Finding the right utility is finally easier!

For most HP3000 system managers, standardization is an unexpected luxury. Owning five separate utility packages means speaking five different languages, having five unrelated manuals and five different support numbers to remember—that's not what we call "efficient."

ALLTOOL™ gives you *more* for less

Now, with ALLTOOL, you have a better alternative to buying and understanding a variety of utility packages. In one fully integrated package, ALLTOOL incorporates the most widely used functions for managing your Classic HP3000* data center.

ALLTOOL is easy to use and has a complete on-line help system, plus a 24 hour technical support line.

ALLTOOL performs operations such as automated

IMAGE database and MPE file functions. ALLTOOL can backup "IN USE" IMAGE databases and MPE files to disk or tape. Recover spoolfiles lost during system restart with ALLTOOL. Use ALLTOOL to save job information to disk or tape for later restreaming. ALLTOOL allows you to view OPEN spoolfiles. It identifies heavy CPU users and manages their queues.

ALLTOOL extends MPE capabilities with complex filesets, file-driven execution and "if...else...endif" fileset criteria. ALLTOOL also offers a full-featured macro language as an interface between itself and existing applications.

THE ONLY FEATURE ALLTOOL DOES NOT HAVE IS A BIG PRICE! Call or write for a complete list of features or to request a demo tape. *ALLTOOL/XL is under development for the Spectrum series.

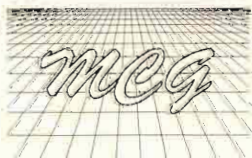

MANAGEMENT CONSULTING GROUP, INC.

637 Wyckoff Avenue, Suite 229

Wyckoff, New Jersey 07481

Phone: 201-891-4949 • FAX: 201-891-8020

ALLTOOL is a registered trademark of Management Consulting Group, Inc.

CIRCLE 232 ON READER CARD

problems with the database? If so, I would be interested to hear from you.

RI 'Violation'

Figure 1 shows the DEPARTMENTS and EMPLOYEES tables in either of the two versions.

MGR# is a foreign key (FK) in DEPARTMENTS referencing the primary key (PK) EMP# in EMPLOYEES. One part of the referential integrity (RI) rule which applies here is:

FK values must match existing PK values.

Now do you see the problem? As applied to these two tables, the RI rule means "Managers must be valid employees." But the DEPARTMENTS table contains rows representing managers whose IDs aren't recorded as EMP#s in EMPLOYEES. This violates RI (in the original database, the EMPLOYEES table does record those employees, which were

eliminated for simplicity).

Figure 2 shows a revised DEPARTMENTS table, which no longer violates RI.

EI 'Violation'

Consider the other requirement for FKs.

A FK value must match some existing PK value, or be totally missing.

Note that despite what I previously stated in the relational model devised by E.F. Codd, this isn't explicit requirement. But even though RI doesn't prohibit partially missing FK values, they *do* create problems and it's a good idea to avoid them anyway.

To illustrate the problems caused by partially missing FK values, I used the ASSIGNMENTS table as an example which has (PROJ#, ACT#) as a composite FK, referencing the PK of the ACTIVITIES table. To quote:

"Suppose the following rows existed

in assignments:

PROJ#	ACT#	EMP#	START	TIME
AD3113	???	260	4/15/82	1.00
??????	70	260	4/15/82	1.00
:	:	:	:	:

where ?'s represent nulls (or missing data).

Can you tell one employee assigned to two project activities from a sheer duplication error? Such ambiguities introduce integrity problems in databases, and may result in misleading or erroneous information. To avoid them, RI prohibits composite FKs from being partially missing."

The RI matter aside, can you detect any problem with this example?

Note that in the ASSIGNMENTS table the PK is (PROJ#,ACT#,EMP#). Thus, the FK (PROJ#,ACT#) is actually also a part of the PK. As such, its two columns are prohibited from containing any miss-

A Computer Room Disaster is Unlikely

CSI offers HP 3000 users reliable Disaster Recovery Services including:

- **Hotsite:** A fully equipped computer facility with office space and equipment
- **Freight-Ready:** Packaged systems, ready for immediate shipment
- **Configurations:**
 - Micro 3000
 - Series 48
 - Series 58
 - Series 70



Ask us about "DP-AID," a PC-based planning tool!

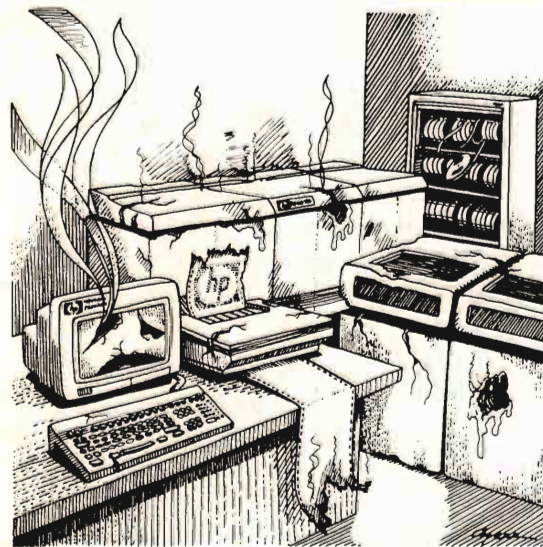

But What If...?

Call today for a complete offering or let CSI configure a system to suit your needs.

Computer Solutions, Inc.



NJ (201)672-6000

CIRCLE 158 ON READER CARD

Massive Storage

2.2 GBytes Mass Storage in a single, compact cartridge about the size of a deck of cards for HP 3000, 1000, and 9000 computers



Echo 4920

- ▼ High-Capacity, Cost-Effective Tape Backup
- ▼ Up to 2.2 GBytes on a Single 8mm Tape Cartridge
- ▼ High Performance – 11MB per minute transfer rate
- ▼ State-of-the-art Helical Scan Technology
- ▼ Supports HP 3000, 1000 & 9000 Computers
- ▼ Emulates HP's Disk and Tape Devices
- ▼ Ideal for Journaling, Archiving, Backup, Restore and Software Distribution
- ▼ Operates either "Off-Line" or "On-Line" using industry standard backup utilities
- ▼ No CPU required for Backup or Restore

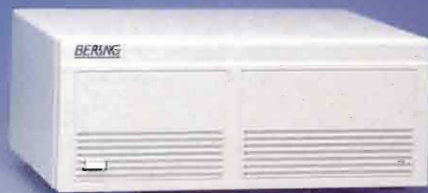

▼ More Memory at Less Cost

The Bering EconoPac Winchester Hard Disk subsystems offer high performance/value for primary storage needs. Available in a variety of capacities from 149MB to 673MB, EconoPac performance drives provide a complete line of high capacity, mass storage solutions for all Hewlett-Packard computers.

BERING

246 East Hacienda Avenue
Campbell, California 95008
800/237-4641 408/379-6900

Bering, Echo, and EconoPac are trademarks of Ocean Microsystems, Inc. HP3000, HP1000, and HP9000 are trademarks of Hewlett-Packard Company, Inc. © Ocean Microsystems, Inc. 1989

CIRCLE 104 ON READER CARD

ing values by the EI rule:

PK values must be unique and cannot be missing.

Consequently, the example given isn't entirely an appropriate one to illustrate the problems with partially missing FK values, because such missing values wouldn't occur if EI were enforced.

A better example would be *Figure 3*. Instead of the DEPARTMENTS table, we have a DIVISIONS table (*Figure 2*).

(DEPT#,STATE) is the FK in the EMPLOYEES table referencing (DEPT#,STATE), the PK in the DIVISIONS table.

If both DEPT# and STATE columns had missing values, that could mean "no current division." But if either value was missing, what exactly does the result mean? The same department could occur in more than one division, and the same division could have more than one department, so what are the PK values in the table referencing, and what type of integ-

FIGURE 3.

DEPT#	STATE	DNAME	MGR#	RDEPT
E21	DC	SOFTWARE SUPPORT	100	E01
E21	CA	SOFTWARE SUPPORT	100	E01
:	:	:	:	:

DIVISIONS Table

EMP#	ENAME	DEPT#	STATE	HIRED	COMM
100	Spenser	???	DC	6/19/80	26150
200	Johnson	E21	??	7/12/75	22070
:	:	:	:	:	:

EMPLOYEES Table

Partially Missing FK Values.

egrity must the system enforce?

This also creates complications for integrity enforcement, as now we have various value combinations of (missing, not missing) accept or reject. It's better, to avoid partially missing FK values.

That the two errors went undetected in even a small and simple database, despite the care invested, clearly demonstrates how risky it is to relegate the enforcement of integrity rules to users in applications. If the rules are determined

and declared to the system upfront, stored in the database catalog, and automatically enforced by the DBMS, the propensity for data corruption (and its effect on decision making) is greatly reduced. —*Fabian Pascal is president of micro-paSQL, a Washington DC consulting firm specializing in relational database management.*

Would you like to continue to see articles on this topic?
 Circle on reader card
 yes 346 no345

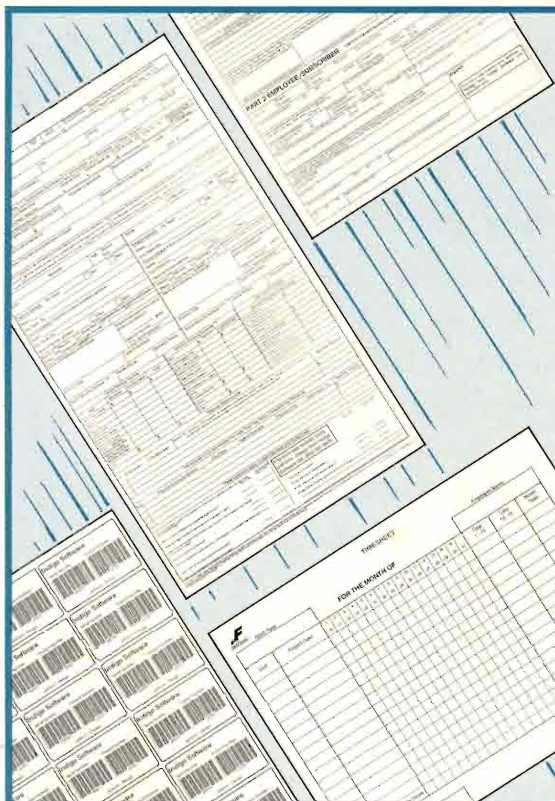

JetForm: A New Form of Power

JetForm is the most powerful electronic forms product on the market. JetForm gives you forms at their very best, along with unlimited applications potential to meet all your business needs.

- JetForm has Design**
 See your form grow on the screen—WYSIWYG under MS Windows. Design your forms with a full set of graphics and text handling tools. Scan and trace pre-printed forms and include graphic images from scanners and paint programs.
- JetForm has Flexibility**
 Design and print all your formatted material—from single-page expense claims to multi-page policies, contracts, barcode labels, and catalogs. Use your choice of stand-alone PCs, PS/2s, networks, minicomputers (HP 3000, HP 9000, DEC VAX), and UNIX platforms.
- JetForm has Speed**
 Merge and print your data in record time, utilizing the full capabilities of your HP LaserJet or PostScript printer.
- JetForm has Power**
 Develop business applications without any programming. Instantly verify entered data and calculate field values. Watch your input be automatically formatted. Retrieve and update records in dBase III or IV files.

Call (800) 267-9976 (613) 594-3026
 Indigo Software Ltd.
 400-560 Rochester Street
 Ottawa, Canada K1S 5K2

JetForm
JetForm 2.00
Its time is now.
Its trademark is Power.

CIRCLE 119 ON READER CARD

Rewritable Optical Drives for Hewlett-Packard Computers with HP-IB Interface

Set Your Sights on Optical – 650MB in One Small Cartridge



Model 7600 Rewritable Magneto-Optical Disk Drive

- ▼ Huge 650MB capacity per compact cartridge
- ▼ Quick, random access to large amounts of data
- ▼ Convenient, removable 5.25 inch cartridge
- ▼ Perfect for high security – take it with you or lock it up
- ▼ Increase capacity by adding a cartridge
- ▼ Economical archival storage with "online" accessibility
- ▼ Very rugged and easily transportable
- ▼ Easily installed, uncomplicated to use
- ▼ Very reliable (head crashes are impossible)
- ▼ Long-life media (10-year minimum)
- ▼ No periodic media reconditioning required
- ▼ Available for HP 9000, 3000, and 1000 computers

BERING™

246 East Hacienda Avenue, Campbell, California 95008, USA 800/237-4641 408/379-6900

CIRCLE 169 ON READER CARD

HP, HP-IB, HP-IB and HP-IB are trademarks of Hewlett-Packard Company, Inc.
© Clean Microsystems, Inc. 1989



PC TIPS

Miles B. Kehoe

MS-DOS Utilities

A professional programmer friend saw my September column and was amazed: She never had seen assembly code written with the MS-DOS debugger. While DEBUG may not be elegant and somewhat clumsy as an editor, it does provide an easy way to enter some kinds of assembly language programs without an editor or assembler. Chalk it up to yet another well kept secret of MS-DOS.

For those who missed it, I provided a small assembly language routine to perform single character input from the Vectra console for use in batch files. By using the program, you can ask questions and accept user input very easily in the course of batch file execution, a feature sorely missing in the standard command language.

But before I summarize this handy little routine, I think it would be appropriate to talk about some other features of MS-DOS batch file programming.

The Right Direction

One capability MS-DOS borrows from UNIX and HP-UX is the ability called "I/O Redirection." This fancy name means that for many MS-DOS applications, you can have MS-DOS perform any standard output not to the screen but to a file. This capability doesn't work in all programs. Some, such as HP Drawing Gallery, rely heavily on direct output to the graphics screen.

All of the standard MS-DOS utilities permit the redirection of output. In addition, any batch commands can usually be directed to a file. This allows you to capture a log of any batch file such as the simple one shown in *Figure 1*.

The output of all of these commands

DEBUG provides a way to enter some kinds of assembly language programs without an editor or assembler.

will be put into a file called TEST.LOG. This will happen because of the greater than symbols (>) redirecting the standard output to the file. The first line has only a single >, which causes MS-DOS to delete any existing file named TEST.LOG, and to create a new log file. Subsequent redirections require the >> symbol, which causes these lines to be appended to the existing file.

Note: If you wanted to append this output to any previous log file, you would use >> in place of > on that first line.

To have a program take standard DOS input from a file rather than the keyboard, you can use the input redirection symbol, illustrated in *Figure 2*, which gives a sorted directory listing.

Some MS-DOS utilities and commands, such as DATE and CHKDSK, ex-

pect input, and by using the input side of I/O redirection, you can provide this input in a batch file. *Figure 3* shows how you can do this to get the TIME and DATE.

When you execute the TIME command from the MS-DOS prompt, it will display the current time and wait for you to enter a new time: Pressing the [Enter] key causes the time to remain unchanged. In *Figure 3*, the file NEWLINE provides the batch equivalent of the [Enter] key. NEWLINE can be created by your favorite word processor, or by simply typing the MS-DOS command:

```
COPY CON NEWLINE
```

Press [Enter] two times, then [CTRL-Z] and a final [Enter]. All done!

An example of how you might find

FIGURES 1-2.

```
@echo off
echo Starting test now > TEST.LOG
chkdsk >> TEST.LOG
dir C: >> TEST.LOG
echo End of test >> TEST.LOG
```

Figure 1: Creating a Log File.

```
@echo off
DIR > LIST.DIR
SORT < LIST.DIR
```

Figure 2: Sorting a Directory Listing.

BREAKTHROUGH PERFORMANCE!!

IMAGINE . . . A software package, for \$6K or less that can make your current H P 3000 run twice as fast and give you the performance of a \$200K CPU upgrade.

RunningMate's Performance Partners - **I/O Mate** and **SortMate Plus** can cut your disc I/O and sorting time in half for applications and report writers too numerous to list.

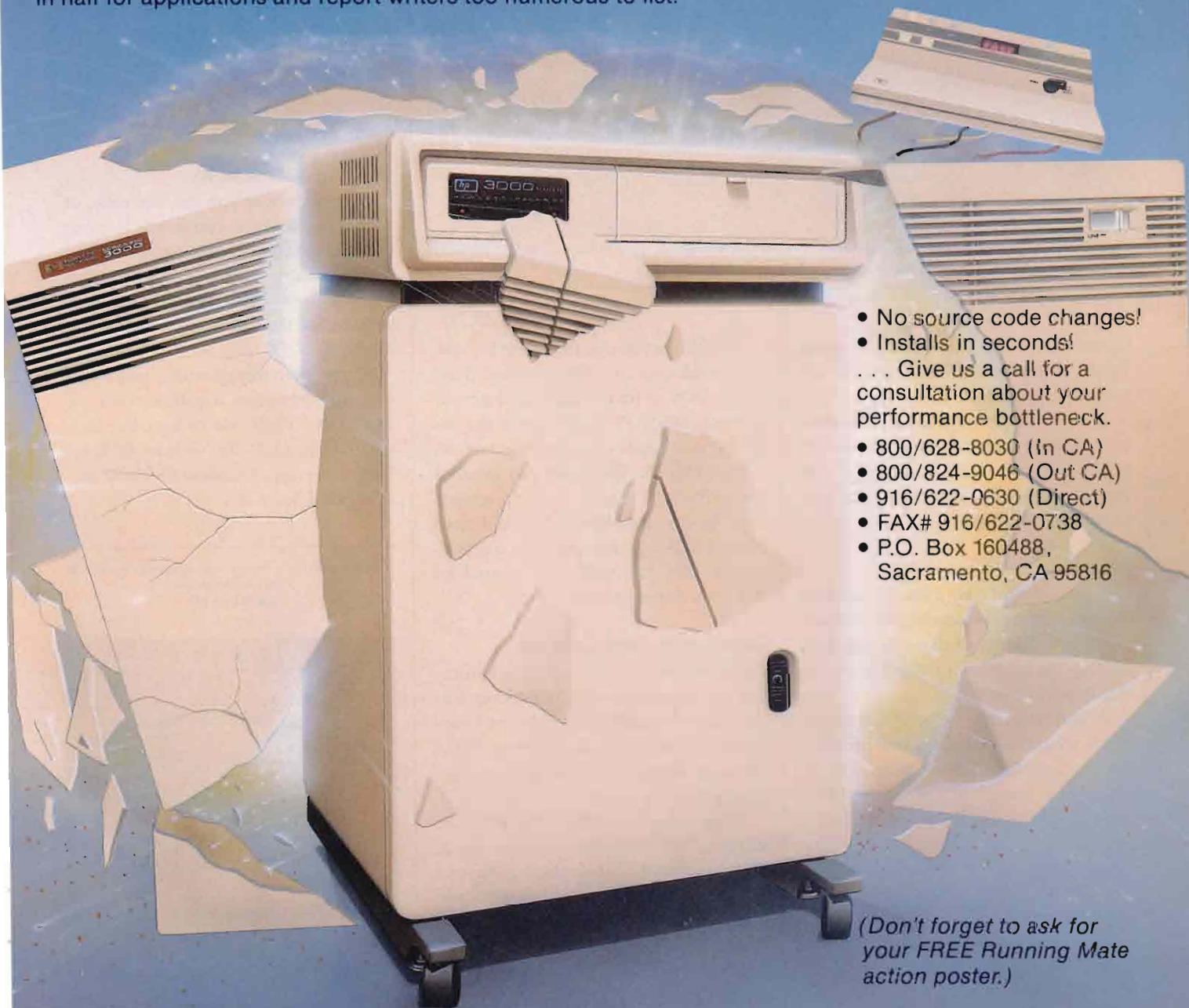

- No source code changes!
- Installs in seconds!
- . . . Give us a call for a consultation about your performance bottleneck.
- 800/628-8030 (In CA)
- 800/824-9046 (Out CA)
- 916/622-0630 (Direct)
- FAX# 916/622-0738
- P.O. Box 160488,
Sacramento, CA 95816

(Don't forget to ask for your FREE Running Mate action poster.)

RunningMate™

THE PERFORMANCE PARTNER

FIGURES 3-4.

```
@echo off
echo What time is it? >> FILE.LOG
time >> FILE.LOG < NEWLINE
echo And what is the date? >> FILE.LOG
date >> FILE.LOG < NEWLINE
```

Figure 3: I/O Redirection in a Batch File.

```
@echo off
echo Starting timing now > TIMING.LOG
time >> TIMING.LOG < NEWLINE
TASK1
echo End of task 1 >> TIMING.LOG
time >> TIMING.LOG < NEWLINE
echo Starting task 2 >> TIMING.LOG
time >> TIMING.LOG < NEWLINE
TASK2
echo End of task 2 >> TIMING.LOG
time >> TIMING.LOG < NEWLINE
```

Figure 4: Simple Batch File Timing.

this useful is when you want to do some simple performance recording of several programs in a batch file. Suppose you want to create a job log to see what time each of three programs started and ended. MS-DOS lets you do this with the TIME command and the batch techniques you already know (Figure 4).

Pipes

The example in Figure 2 created a sorted directory listing by sending the output of the DIR command to a file, and then sending the contents of that file to the SORT command.

A handy feature of MS-DOS is the ability to send output from one program directly into another program. This is based on a feature in UNIX and some other operating systems called "piping."

```
@echo off
DIR | SORT
```

The example above shows piping at work by specifying the vertical bar character (|) to link applications. There's virtually no limit in how many programs can be linked together as long as they all accept standard input and output.

For the purist out there among you, let me admit to a small technical detail of MS-DOS. With its single-tasking background, MS-DOS doesn't have the sophisticated pipes of operating systems such as HP-UX. Whenever you specify a pipe, MS-DOS silently creates a temporary file for the output, so you'll need to plan sufficient disc space for any temporary files that might be created by MS-DOS during piping.

Debugging This Column

At the beginning of this column, I promised to review the use of DEBUG to create small executable programs. As I suggested, DEBUG isn't an easy way to enter code, because it's difficult to correct typing or entry errors.

Like most MS-DOS commands and utilities, DEBUG accepts redirected input, and by using this feature you can overcome the problem of bad typing in creating programs with DEBUG. Consider the list of commands I entered in DEBUG last month to create the initial file (Figure 5).

Because of I/O redirection, I can create an ASCII file that includes the above lines, and direct that ASCII file into DEBUG. This way, I not only can create small programs, I can edit them and

try again. Store the above commands in a file called SESSION.LOG using an ASCII editor or the MS-DOS COPY command. Be sure to include the blank line indicated by the using [Enter].

Note also that the value 10 represents the number of bytes to be written to disc: If you enter a longer program, be sure to change this number accordingly.

To create the GETCH.COM file, simply invoke DEBUG as follows:

```
DEBUG < SESSION.LOG
```

Coming Attractions

You've seen how you can use some of the simple MS-DOS commands in batch files and how to manipulate some data. In the coming months, I will be showing you more batch file tricks, as well as some of the less known features of MS-DOS.

If you have any questions you'd like me to address, feel free to contact me through *HP Professional* or its online Bulletin Board, ARIS/BB. —Miles B. Kehoe is an online support manager for Verity Inc., Mountain View, CA.

Would you like to continue to see articles on this topic?
Circle on reader card
yes 348 no 347

FIGURE 5.

```
A 100
MOV AX, 0600
MOV DL, FF
INT 21
JZ 010F
OR AL, 20
MOV AH, 4C
INT 21
RET
[Enter]
RCX
10
N GETCH.COM
W
Q
```

Session log in DEBUG.

JobRescue saves your operations critical resources

JobRescue™ from NSD saves you two of the most important resources in business - *time and money*. But these are not the only critical things we save you.

For starters, this HP3000 software substantially improves operator productivity: 1) by automatically checking for errors as soon as a job logs off; 2) by allowing on-line access and reprints of \$Stdlists/ Reports; and 3) by eliminating the need for manual logging and starting of jobs and manual distribution of reports.

JobRescue saves you considerable paper and printer costs too. And you can keep reports on-line based on time or number of generations. You can even specify exactly what will be printed out- partial reports, error \$Stdlists, whatever.

For you this means far better communications.

Using JobRescue, you're able to trap all errors and choose from a variety of convenient ways to alert support personnel. You can even run multi-threaded production jobs based on a calendar for days, months, or years at a time.

So if you want to dramatically improve your operations, call us about JobRescue today. And start saving immediately!

JobRescue saves you time, money, paper, and headaches - allowing operations to run smoother, faster, and better than ever before.



NSD

1670 South Amphlett Blvd., Suite 103,

San Mateo, CA 94402 1.415.573.5923

(In CA) 1.800.538.9058 (Outside CA) 1.800.538.3818

(In Canada) 1.800.445.3818

JobRescue is a trademark of NSD, Inc
CIRCLE 129 ON READER CARD



HP-UX

Andy Feibus

Create Formatted Documents

Using macros within HP-UX's documentation facility **nroff**,

helps create nicely formatted documents. An **nroff** macro is a set of **nroff** commands that can be either invoked by name or automatically executed at any place within the document. A macro name can contain either one or two characters and can redefine any existing **nroff** construct. To define a macro, use the general form:

```
.de macro_name
(macro command lines)
..
```

The **de** command defines the beginning of the macro and associates a macro name with the macro. The two periods mark the end of the macro definition. To invoke a macro, use the command line:

```
.macro_name [ arg1 [ arg2 [ ... ] ] ]
```

where **arg1**, **arg2**, etc. are optional arguments to be passed into the macro (similar to subroutine arguments). To reference these arguments within a macro, reference the registers **\\\$1**, **\\\$2**, etc. When a macro is defined, all *in-line commands* (those prefaced by the current escape character) are interpreted. To delay this interpretation until the macro is **invoked**, precede any register references with two escape characters (i.e., **\\%** is interpreted as **\%** when the macro is defined and as the contents of the page number register when the macro is invoked).

To automatically execute a macro when a specific line in a page has been output, use the command:

```
.wh loc macro_name
```

where **loc** is the position in the page of the output line to trigger the execution of the macro. If **loc** is greater than 0, then the position is relative to the top of the page; if **loc** is less than 0, the position is relative to the bottom of the page; if **loc** is 0, the position is the top of the page.

For example, to execute a macro at the top of the page, use the command **.wh 0 macro_name**. To execute a macro when the page position is one inch from the bottom of the page, use **.wh -1i macro_name**. A quick example to create a header and a footer for each page could be:

```
.de hd
'sp 1
..
.de fo
.tl'Article 9'Page %'by Andy Feibus'
'bp
..
.wh -1i fo
.wh 0 hd
```

The **tl** command, shown above, is used to output a three-part title line. The format for this command is:

```
tl'left'center'right'
```

where **left** is the text to be placed along the left margin of the line, **center** is the text to center on the line, and **right** is

the text to be placed along the right margin of the line. Within this command, **%** displays the value stored in the **nroff** page number register. The **tl** command is the only **nroff** command that permits the use of the page register without prefacing the register with the escape character.

The macro example above isn't provided to encourage you to write macros; macros can be very cumbersome to create or modify. Luckily, HP-UX comes with a standard set of macros, called the **MM** macros, that provide some very powerful documentation constructs.

The **MM** macros are so named because of how documents containing these macros are formatted:

```
$ nroff -mm document_file
```

The **MM** macros rely more on registers than standard **nroff** commands. For example, the **MM** macro for indicating a new paragraph is **P** (invoked using **.P**). To indent the first line of each paragraph, set the register **Pt** to 1, as follows:

```
.nr Pt 1
```

If **Pt** is set to 0 (default), paragraphs aren't automatically indented. If you

TABLE

Register	Usage
Hc	Center the heading text (default = 0).
Hb	Separate the heading from the section's text first paragraph (default = 2).
Hs	Heading is separated from body of section by a blank line (default = 2).

Registers can be set to control the output of headings.

Who says you can't improve on a good thing?

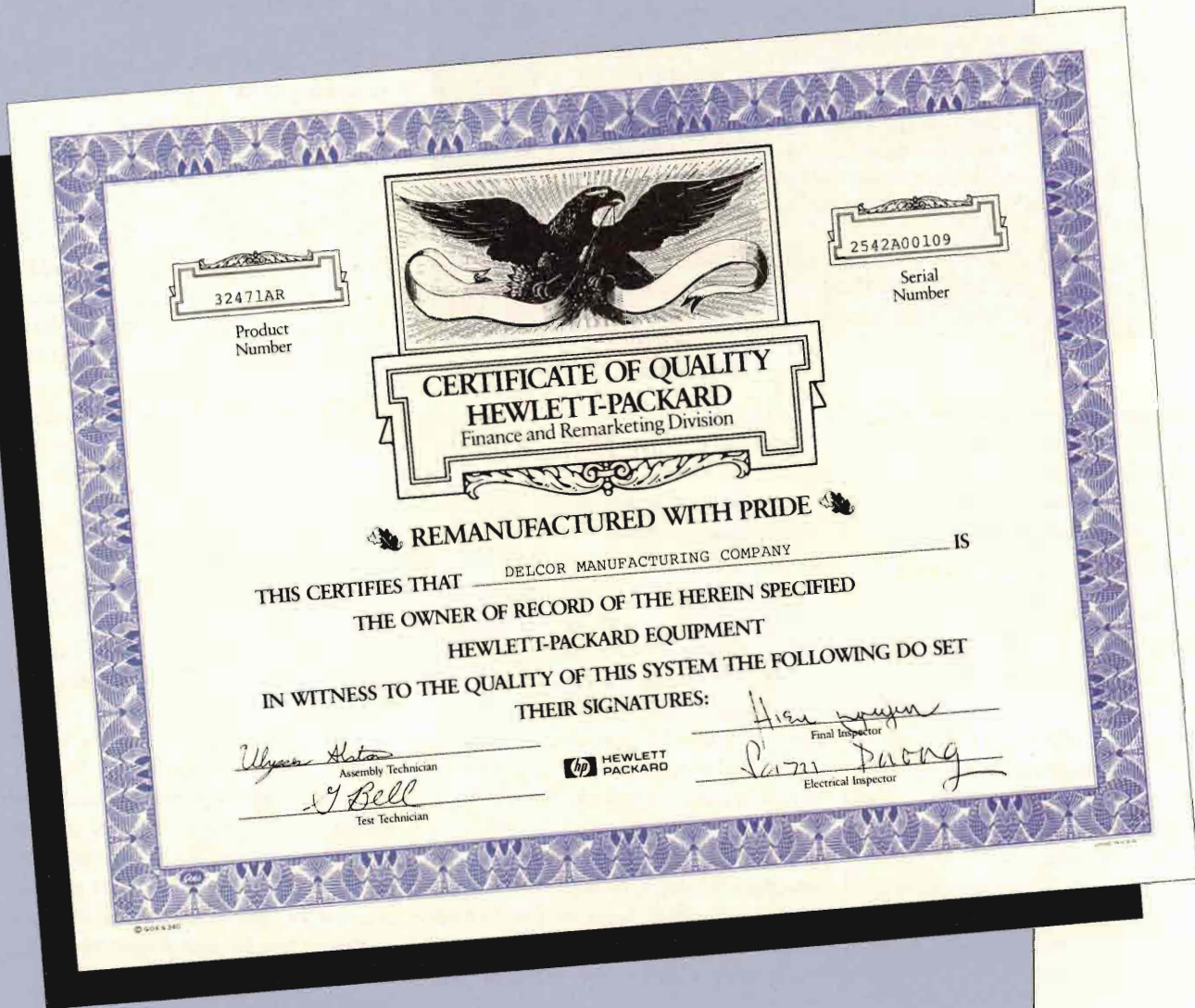

Hewlett-Packard products have long been synonymous with high quality. Now, you can get that same quality in HP's line of **remanufactured equipment** for **less money**—and with the **same warranty** as new HP products.

But that's not all. When you buy remanufactured products from Hewlett-Packard, HP's team of sales, service and support people

stand ready to provide the added value you can't get anywhere else.

Here are a few of the many services HP provides at no extra cost to you:

- Pre-shipment site preparation and verification
- A thorough implementation support and service plan
- All documentation, manuals and cables

- Insured equipment delivery
- Complete installation

In other words, more for less.

The remanufactured products solution from Hewlett-Packard.

There is a better way.



TABLE 2

Macro	Effect
DL indent	Dashed list. Each item is marked by a dash (-) followed by one space. Indent is the number of spaces to indent before the first character in the text of the list items.
BL indent	Bullet list. Each item is marked by a bullet followed by one space. Indent is the number of spaces to indent before the first character in the text of the list items.
ML mark indent	Marked list. Specify the mark character to precede each list item. The indent argument is the same as for BL and DL .
AL type indent	Numbered list. Specify the type of numbering format to use (same as the argument for the HM macro, above). The indent is the same as for other list macros.

List initialization formats.

want to automatically number your paragraphs, use the **nP** macro to indicate a new paragraph. This macro operates with the heading macro, which is invoked for every new heading level as follows:

```
.H level text
```

where **level** is the level number of the header (1 is main level, 2 is next level, etc.; a maximum of seven levels is permitted) and **text** is the text for the heading (enclosed in double quotes). An example of the **nP** macro and the **H** macro is the following:

```
.H 1 "Top level heading"
.H 2 "2nd Level"
.nP
Hello.
```

which results in the following output:

```
1. Top level heading
1.1 2nd Level
1.01 Hello.
```

The numbering of a paragraph is always relative to the first-level heading. Set the register **Ej** to the **level** number corresponding to the largest heading level to cause a page eject. In other words, to

start all first- and second-level headings on a new page, use the command **.nr Ej 2**.

Other registers may be set to control the output of headings. The value for these registers is used in the same way as the **Ej** register (the value indicates the largest heading level to use this feature). These registers are listed in *Table 1*.

When headings are displayed, all section numbers are, by default, concatenated together to generate the heading number. To reduce this heading number to a single number followed by a period, use **.nr Ht 1**.

By default, all headings numbers are automatically displayed as a concatenation of the numerical form of the section numbers. To use letters or roman numerals, instead of digits, use the following macro:

```
.HM [arg1 [ arg2 [ ... ] ]
```

where **arg1** is the type of numbering for first-level headings, **arg2** is the type or numbering for second-level headings, etc. A maximum of seven arguments may be set. The possible values for each argument is: **I** (uppercase roman numeral), **A** (uppercase alphabetical letter), **1** (digit), **i** (lowercase roman), and **a** (lowercase letter). Each argument is separated by at least one space.

To display an unnumbered heading, use the **.HU heading_text** macro. This macro displays a heading that is considered to be at the same level as the contents of the **Hu** register (which you can adjust; the default value is 2); however, the heading text isn't prefaced by the section number.

To collect all headings into a table of contents page at the end of your document, set the **CI** register at the top of your document as follows:

```
.nr CI level
```

where **level** is the maximum heading level to store for the table of contents. At the end of your document, invoke the **.TC** macro to generate the table of contents.

At the beginning of this article, an example was shown of two macros to place a header and a footer on each page. The **MM** macros provide these macros:

```
.PH "'left'center'right'"
.PF "'left'center'right'"
```

These macros should be used instead of the example header and footer macros. The **%** character implies the page number register in these macros (similar to the **tl** command).

Certain **nroff** formatter commands should be avoided while using the **MM** macros. For example, use the **SK** macro to skip to the top of the next page instead of the **bp** command. The **SK** macro performs header and footer processing and **bp** doesn't. Also, use the **SP** macro instead of the **sp** command to skip vertical spaces. Successive **SP** macro calls don't produce the sum of the **SP** arguments, only the largest argument. For example, the following produces only three blank lines:

```
.SP 2
.SP 3
.SP
```

Within many documents, lists are created. The **MM** macros provide many

Certain *nroff* formatter commands should be avoided while using the **MM** macros.

ways to format lists. A list, within **MM**, contains three parts: a list initialization macro, a list item macro, and a list ending macro. Lists can be nested up to six levels.

The list initialization macro defines the type and format for the items in the list. Some of the possible list initialization formats are found in *Table 2*.

To indicate a list item, use the LI macro. To terminate a list, use the LE macro. For example:

```
.DL 4 \ " Start a dashed list
.LI
Item 1
.LI
Item 2
.ML + 5 \ " Start a marked list
.LI
Item 2.1
.LE \ " End the marked list
.LI
Item 3
.LE \ " End the dashed list
```

results in the following output:

```
- Item 1
- Item 2
+ Item 2.1
- Item 3
```

That's it for this month. All information discussed can be found in the *HP-UX Concepts and Tutorials: Text Formatters* manual. Next month, I'll show you how to add tables to your documents. —*Andy Feibus is president of Processware Inc., Atlanta, GA.*



The application builder for the HP3000

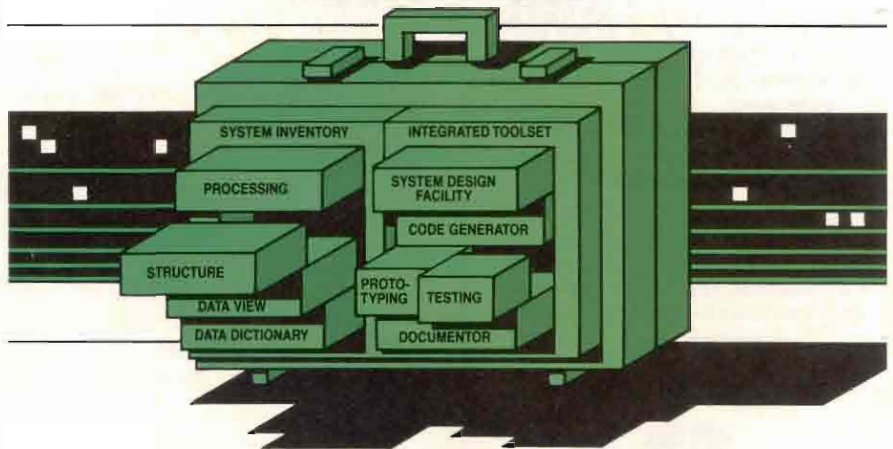

Our open and shut C.A.S.E.*

*Computer Aided Software Engineering

▼ Can you afford to...

- tie up 80% of your resources on maintenance?
- finish projects up to 100% over budget and behind schedule?
- lose business opportunities because of obsolete or faulty applications?
- pay for costly "run-time support" for programs that "crawl"?

▼ When you can have today...

- **QUALITY ENGINEERED** applications, designed to accommodate future changes now.
- **INCREASED PRODUCTIVITY** in development, through re-usable components and a powerful set of tools.
- **USER SATISFACTION** with easily maintainable, reliable and highly featured applications.
- **PERFORMANCE** that only compiled COBOL can give, at *no extra cost*.

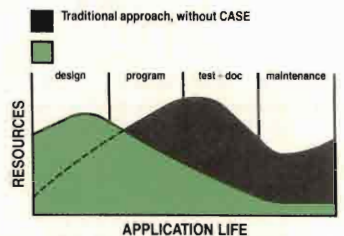

Call or write today RAET 1-800-338-3772

Quality Consultants, Inc., 1775 The Exchange Suite 140, Atlanta, GA 30339

New England
Wescom Systems, Inc.
(617) 769-4344

Mid West
O'Brien Downs Systems, Inc.
(513) 891-9300

Canada
COA Computer Systems, Inc.
(416) 333-0611

West Germany
**Armin Knoblauch
Industrieinformatik**
0931/27 46 61

South East
Quality Consultants, Inc.
(404) 980-1988

South West
**Information Systems
Professionals, Inc.**
(714) 778-1818

Australia
Field Technologies Pty. Ltd.
(03) 662-3329

Netherlands
RAET N.V.
(085) 246 911

Artesa is a registered trademark of RAET Software Products B.V.

CIRCLE 134 ON READER CARD

UNIX is a registered trademark of AT&T in the U.S.A. and in other countries.

MS-DOS is a trademark of Microsoft.

Macintosh is a trademark of Apple Computer Inc.

X Window System is a trademark of MIT.

Microsoft is a registered trademark of Microsoft Corp.

Would you like to continue to see articles on this topic?
Circle on reader card
yes 350 no 349

**WHEN PRICE
IS NO OBJECT,
YOU CAN AFFORD
TO GET THE VERY
BEST...EVEN IF
IT COSTS LESS!**

If you need a powerful payroll system, join the ranks of some of the nation's most prestigious companies — and try The Cort Payroll system. You'll get accruals, 401k, user defined data items, special computations — even a report writer. It's easy and priced right — from \$1200 to \$4250. Start by calling for a free manual TODAY... And ask about our real-system trial plan.



65175 Cline Falls Rd. • Bend, OR 97701 • (503) 388-3800

CIRCLE 182 ON READER CARD

**BUY A BIT
AT A TIME**

The Computer Museum Store Catalog has an array of high tech books, posters, jewelry and gadgets to fire the brain — and warm the heart — of every computer-user on your list.

Call or write for your free catalog or plan to visit The Computer Museum soon.

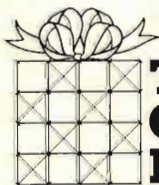

**The
Computer
Museum**

300 Congress Street, Museum Wharf,
Boston, MA 02210 617/426-2800

CIRCLE 152 ON READER CARD

Continued from page 12.

HP produces a range of ASICs (application-specific integrated circuits) used in its computers and instrumentation products. The chips range from silicon CMOS for low-end computers to powerful BiPolar and Gallium Arsenide chips for instruments.

HP's semiconductor expertise enabled the company to introduce its HP-PA line without using CPU chips from other vendors. Two years ago HP gained a competitive edge over Digital because the HP-PA systems used lower powered NMOS III chips that rivaled the performance that Digital's VAXes attained with the more expensive and power-hungry ECL (emitter coupled logic) technology.

But times have changed. Now that other companies are producing fast RISC chips, HP is under more pressure to deliver faster high-end systems more quickly than would be possible were it not for outside sources to supply powerful chips. Starting a production line for a new semiconductor technology would be prohibitively expensive even if the company knew it could get a high-volume, low-cost operation in a very short time.

The safe bet for getting a new process technology these days is to order out rather than cook at home. HP needs BiCMOS technology because it's faster than CMOS but less power-hungry than ECL. Currently Hitachi is the leading supplier of BiCMOS chips. Through its partnership with Hitachi, HP will learn how to produce BiCMOS chips and both companies will manufacture a new chip set for use in high-performance workstations, servers and multiuser systems. In exchange for this help, Hitachi gains the right to use HP-PA chips in products it markets under its own brand name. To date, it hasn't yet been decided whether HP also will license its HP-UX operating system and optimizing compilers to Hitachi.

Semiconductor Suppliers

In contrast to the Hitachi deal that allows HP to learn about BiCMOS fabrication, HP will be the tutor rather than the pupil

in the Samsung deal when the two companies codevelop a new submicron CMOS. HP will share its expertise in submicron CMOS with Samsung. Samsung is permitted to manufacture HP-PA chips, put them into its own workstations and distribute HP-UX. Because HP already knows how to make the chips they will be doing with Samsung, what's in it for them?

HP sees Samsung as a company that can adhere to a rigorous production schedule and get products to market quickly. When Samsung announced that it would set up a production line for 1 MB DRAMs (dynamic random access memory) and then began shipping product within a year, HP Executive Vice President Lew Platt was duly impressed.

These days, all system vendors are looking for reliable suppliers of memory in case there are shortages in the future. Having formed alliances with two memory vendors, HP is positioning itself to have a steady supply of memory chips. For times when HP's foundries aren't able to meet the demand for HP-PA chips, the agreement has a provision for Samsung to sell chip sets to HP.

Strategic Geographic Markets

Competing in the RISC market is somewhat like playing a game of Risk. A company needs to have a fortification in each of the three technology regions of the world, North America, the Pacific Rim and Europe. The Pacific Rim is strategically important because that's where most of the memory chips are produced. It doesn't require a partnership to buy the fast SRAMs (static random access memory) that HP and other RISC vendors need to keep the memory in line with the ever-increasing speeds of its processors. On the other hand, buying electronics industry supplies is harder than buying chip products. Many Japanese and Korean electronics industry suppliers are unaccustomed or even unwilling to trade with U.S. vendors. Samsung and Hitachi will be able to arrange some deals that would be harder for Hewlett-Packard to pull off on its own, despite having had a subsidiary

in Japan for more than 25 years.

The spectre of Fortress Europe in 1992 has RISC vendors scrambling to form alliances with European countries before it's too late. The Common Market hasn't yet decided upon tariff schedules, but there most likely will be a high tariff (some predict 18 percent) for products with no European content. The easiest way to get European content is to have European chips. In February, MIPS Computer Systems announced that the West German Siemens would produce MIPS' RISC architecture. In August, Sun revealed that the Dutch company Philips will develop and build SPARC chips. Can HP be far behind? I expect there to be a European licensee for HP-PA within six months.

Faster Product Introductions

When HP introduced the HP-PA line two years ago, the company promised a scalable architecture because there were projects in its labs to produce CMOS for low-end workstations systems and ECL for high-end systems. In those days, product development cycles were longer, and customers had little choice but to wait for their vendor to develop and ship new product. These days, customers have plenty of choices at extremely competitive prices. Gone are the days when HP could expect customers to wait patiently through long product development cycles.

Having Hitachi and Samsung as partners is a faster way to make good the promise of scalability. At the high end, Hitachi has agreed to produce a BiCMOS chip set by 1992. Samsung plans to bring out its low-cost workstations based on HP's submicron CMOS process even sooner.

According to Laura Cory, HP customers can expect to see price/performance increases at the rate of 50 to 70 percent a year. Without the help of technology and manufacturing partners to keep the costs down and to reduce time to market, HP couldn't make such promises to its customers.

In the race to produce the fastest and cheapest RISC machines, it's not what you do but who you know that counts.

FAX 3000

The powerful
new software
that sends
faxes directly
from your
HP3000

Use it to send:

- Letters
- Invoices
- Purchase Orders
- Special Forms
- and Much More!

STR SOFTWARE COMPANY

3601 SWEETHORN COURT

Call: (703) 689-2525

FAIRFAX, VA 22033

Fax: (703) 689-4632

CIRCLE 179 ON READER CARD

Plug the documentation hole in your information storage system!

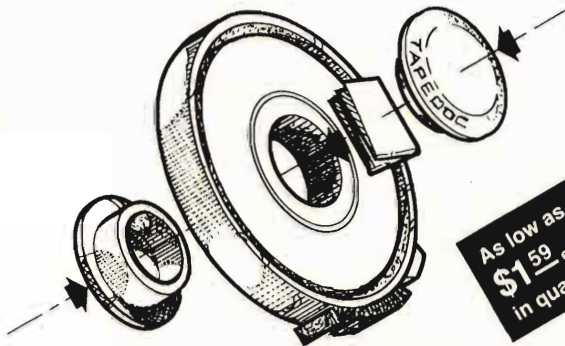

As low as
\$1.59 each
in quantity.

With the remarkable TAPEDOC™ tape documentation hub.

- Stores up to eight pages of directory information with each tape.
- Does not interfere with tape storage in a standard rack.

To order or for more information, contact:

TAPEDOC

P.O. Box 39550
Phoenix, Arizona 85069
(602) 241-8470

TAPEDOC is a trademark of Computer Systems Engineering, Inc., Phoenix, Arizona.

For a box of
5 samples send
\$10.95 + 2.40
postage &
handling.

Continued from page 26.

Now application designers have an Integrated CASE product on the HP 3000 that eases the rapid construction and maintenance of COBOL applications with relational data management.

Existing IMAGE, KSAM and serial file management remains fully supported. Contact QCI, 1775 The Exchange, Suite 380, Atlanta, GA 30348; (800) 338-3772.

Circle 392 on reader card

Auto Paper Sizing Added To JetFax Line

Hybrid Fax Inc. announced a number of enhancements to its JetFax product line. The JetFax delivers plain-paper fax onto an office laser printer, eliminating the need for unwieldy thermal paper, while costing a fraction of standard plain-paper fax machines.

Enhancements include automatic paper-sizing capability, which reduces incoming fax pages to fit onto a single 8 1/2- x 11-inch letter-sized page. This feature now is available when the JetFax is used in conjunction with the JetFax Accelerator cartridge. For applications involving receipt of international and legal-size faxes on the single-bin HP LaserJet Series II printer, users will be assured of receiving their faxes on letter-size paper, making them easier to handle and store.

For the dual-bin HP LaserJet Series IID printers, the JetFax detects the size of the incoming fax page, and selects the proper paper tray on which to print it.

Contact Hybrid Fax Inc., 1733 Woodside Rd., Suite 355, Redwood City, CA 94061; (415) 369-0600.

Circle 384 on reader card

Perspective Utilizes Windows Style Interface

TEI has announced changes in its project management package, Perspective. The HP 9000 (HP-UX Series 300 and 800) now is available with a windows style interface, VUE. The name change will provide consistency with the DEC VAX version of software. In addition to the new interface, VUE has added the ability to use multiple calendars within a project. It also has a new memo and note text editor and numerous other enhancements.

The HP 3000 version of Perspective has been rewritten using PowerHouse from



Hybrid Fax offers enhancements to the JetFax product line that are compatible with the HP LaserJet Series II.

Cognos. All screens are in Quick, and Quiz is utilized for standard and custom reporting.

Reporting options include graphics output for laser or dot matrix printers and plotters. Also included are 14 standard management reports or you can develop reports with an integrated report writer.

Other features include: Multi Project processing, Micro to Mini data exchange, forecasting for resource, cost and risk analysis, work breakdown structure and a cost module. Contact, TEI Inc., W. 1527 Shannon Ave., Spokane, WA 99205; (509) 327-2575.

Circle 390 on reader card

Trimlink-400 4-Port Synchronous Data Compressor

The Trimlink-400 is a four port synchronous data compressor. Using a unique proprietary compression technique based on Ziv-Lempel algorithm, the Trimlink-400 compresses the data on each of four channels, individually. It then statistically multiplexes all channels into a single aggregate that can operate at data rates up to 19.2 kbps.

The Trimlink-400 achieves an effective compression ratio of 3:1 or better on each subchannel. The combination of data compression and statistical multiplexing results in total throughput improvement of 4:1 or better.

The subchannels can be configured independently with different parameters at each end (data rates up to 19.2 kbps, hard or

soft flow control, protocol). Each channel can compress bit or byte oriented protocols (SDLC, HDLC, BSC, DDCMP, etc.). This enables the Trimlink-400 to support applications with IBM, DEC, HP and other environments simultaneously.

Contact RAD Data Communications Ltd., U.S. Headquarters, 151 W. Passaic St., Rochelle Park, NJ 07622; (201) 587-8822.

Circle 389 on reader card

TQC's TekBase Enhanced With Database Capability

Test Quality Co. (TQC) has announced new features and enhancements that have been added to TekBase, its technical data management and analysis software system designed for scientific and engineering applications.

The new enhancements provide complete database compatibility with TekBase/UX faster database access, new query language functions and a variety of enhancements to simplify manipulation and reporting of scientific data. The new release also adds TekBase support for the new MC68030-based HP 9000 workstations.

New TekBase features include: a collect command that allows a column of data to be retrieved from a relation and assigned to an array for further processing; a sequence command that searches for appropriate indexes or creates indexes as needed.

TekBase 3.0 supports the HP 9000 Series 200 and 300 family of workstations and

What you should know before (or after) acquiring accounting software from your manufacturing software vendor.

Many organizations assume a vendor specializing in manufacturing software naturally has a top notch accounting system. Not so.

While they may offer a quality manufacturing package, their financial software is often little more than an afterthought. Spend several years with their accounting systems and that fact could become sadly evident.

We'd like to suggest an alternative—Mitchell Humphrey & Co. We offer flexible, feature-rich accounting software that *works with* your manufacturing system while it keeps pace with your changing business needs.

You see, MH&Co. develops financial management systems. Period. With 12 years of experience and several

hundred installations throughout the world, chances are we have just what you are looking for.

So if you're looking for quality financial management software, look to a specialist.

After all, you wouldn't buy your manufacturing software from a vendor who didn't specialize in manufacturing systems. Why trust your accounting software to anyone less than an industry leader.

A leader whose only business is the accounting software business.

To take a closer look at what our software can do for your organization, call Ken Benvenuto at 1-800-237-0028.

Or write us at 11720 Borman Drive,

St. Louis,
Missouri 63146.

MITCHELL HUMPHREY & CO.

Exceptional Software for Exceptional Organizations

CIRCLE 197 ON READER CARD

IEEE 488 Solutions

- Hardware and software interfaces for PC, AT, 386, PS/2, Macintosh, HP, SUN & DEC
- IEEE device drivers for DOS and UNIX®
- IEEE control for Lotus 1-2-3 & Symphony
- PC menu-driven analysis software
- IEEE extenders, expanders & buffers
- IEEE converters to RS-232, RS-422, SCSI, modem, Centronics, analog I/O & digital I/O

LOtech

(216) 439-4091

Telex 6502820864 • Fax (216) 439-4093
LOtech, Inc. • 25971 Cannon Road
Cleveland, Ohio 44146

Call for your **FREE Technical Guide**
Demo disks & application notes available

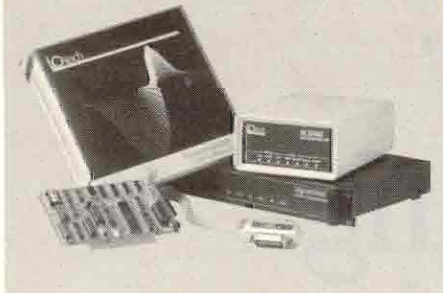

CIRCLE 123 ON READER CARD

Teach Me/ 3000™

- * Train new employees on the HP 3000
- * Modules range from introductory material to system management
- * Modules on IMAGE, VPLUS, COBOL and Dictionary for the programmer
- * Less expensive than sending your staff to off-site classes
- * Better trained employees become more productive, they have higher morale
- * Improved job satisfaction leads to lower employee turnover
- * Authoring language available to write your own modules
- * Free demonstration tape available of all modules and authoring language

For more information, contact:
Innovative Software Solutions, Inc.
10705 Colton Street
Fairfax, VA 22032 U.S.A.

**INNOVATIVE
SOFTWARE
SOLUTIONS**

CIRCLE 120 ON READER CARD

NEW PRODUCTS

instrument controllers running Rocky Mountain BASIC and PASCAL. Databases created with TekBase are compatible with those created using TekBase/UX, which supports the HP 9000 Series 300 and 800 computers.

Contact Test Quality Co., 2316 Walsh Ave., Santa Clara, CA 95051; (408) 986-8880.

Circle 383 on reader card

IEM Extends Memory For HP 1000 Computers

IEM Inc. has expanded its line of memory products with the model EX-2100 series of memory boards for HP 1000 A-series computers. These memory boards for A400, A600+ and A700 computers are available in capacities of 4, 8 and 16 MB.

The models EX-2104 (4 MB card), EX-2108 (8 MB card) and EX-2116 (16 MB card) are 100 percent plug-in compatible with HP's 12103 series memory products, and can be installed on any address boundary evenly divisible by 512 KB. These memory cards are self-configuring, so no switch settings are needed. A green LED on the card alerts the user if a parity error occurs.

Contact IEM Inc., P.O. Box 8915, Fort Collins, CO 80525; (303) 223-6071 or (800) 321-4671.

Circle 382 on reader card

WordPerfect Office Available On UNIX Systems

WordPerfect Corp. has released WordPerfect Office, an office automation package, for SCO XENIX. WordPerfect Office now is available for three different platforms: PC LANs, DEC VAX computers and UNIX systems.

Designed to increase productivity, WordPerfect Office streamlines interoffice communications by allowing UNIX systems users to exchange mail, files and phone messages.

Contact WordPerfect Corp., 1555 N. Technology Way, Orem, UT 84057; (801) 222-5300.

Circle 386 on reader card

INTERTEC Releases V2.27.00 Of MAP/3000

INTERTEC Diversified Systems Inc. (Palo Alto, CA) announced the release of version 2.27.00 of MAP/3000, the MRP II software package consisting of 15 fully integrated

modules dedicated to the HP 3000 platform. Recent enhancements include lot control tracking, multicurrency, expanded PO history and part-by-manufacturer tracking. Enhancements are implemented twice yearly by INTERTEC's Software Engineering Staff prioritized by customer need and market requirements. Customization is also available and includes support for the life of the product.

Contact INTERTEC Diversified Systems Inc., 2625 Park Blvd., Palo Alto, CA 94306; (415) 326-8900.

Circle 391 on reader card

Persoft Offers Terminal Emulator

Persoft Inc. now offers unlimited site licenses for its full-featured HP 2392 text terminal emulator, SmarTerm 2392. IBM personal computer users, or those using compatibles, may now purchase a site license and have an unlimited number of users communicate with HP host computers using SmarTerm 2392.

SmarTerm 2392, Persoft's initial HP emulation product emulates HP 2392's text terminal including HP, ANSI and EM52 modes. The product, supports HP 2392 terminal user-definable keys and operating states, such as character and block modes. In addition, SmarTerm 2392 includes HP 2392 terminal display memory of up to four pages with reverse scrolling.

Contact Persoft Inc., UW Research Park, 465 Science Dr., Madison, WI 53711; (608) 272-6000.

Circle 379 on reader card

Micron Offers Memory Expansion Boards

Micron Technology Inc. announced the availability of the Intensify LJII/IID series. These low-cost, highly reliable memory expansion boards provide one, two or four MB memory upgrades for the HP LaserJet II, HP LaserJet IID and compatibles.

Intensify LJII/IID maximizes laser printer performance in widespread advanced graphics applications in such areas as desktop publishing and CAD/CAM.

The board also contains design features that provide greater reliability than existing boards. The Intensify LJII/IID has been designed with fewer chips, condensing functionality in order to enhance reliability and reduce manufacturing costs.

Contact Micron Technology Inc., 2805 East Columbia Rd., Boise, ID 83706; (208) 386-3900.

Circle 377 on reader card

Tektronix/LP COM Upgrades LAN Protocol Analyzer

Tektronix/LP COM has upgraded its LAN protocol analyzer for its TC 2000 multifunction and TC 1000 portable, single-function test system. The new product provides Ethernet compatibility, collision detection, an increase in overall performance and improved memory capacity.

The new LAN protocol analyzer measures network activity and performance, identifies and locates problems, decodes and analyzes packet data and helps managers to plan network growth. In addition to Ethernet support, it also is compatible with the IEEE 802.3 standard, including StarLan.

The TC 2000-B7 and TC 1000-B7 LAN protocol analyzers are available 30 days ARO for \$28,500 and \$15,600 respectively.

A board-only subsystem is also available for \$10,950.

Contact Tektronix Inc., LP COM Subsidiary, 205 Ravendale Dr., Mountain View, CA 94043; (415) 967-5400.

Circle 381 on reader card

Forms Accelerator Improves Oracle Database Performance

Performance Technologies Inc. (PTI) has announced the Forms Accelerator, a new software accelerator and performance monitor for the Oracle database.

Running transparently with Oracle's SQL*Forms, the Forms Accelerator improves system performance and programmer productivity with no programming changes.

The Forms Accelerator decreases the CPU usage of SQL*Forms based applications. The CPU savings enable current users to realize up to 50 percent faster response times, and more new users to access the Oracle database.

The Forms Accelerator gives database administrators complete control over

SQL*Forms' memory usage. If there's available memory, the amount of cached SQL statements can be increased to improve performance. Anytime the memory usage needs to be reduced it can be scaled down. The Forms Accelerator gives the user complete flexibility.

Contact Performance Technologies Inc., 276 Chestnut Hill Ave., Suite 9, Boston, MA 02135; (617) 787-1776.

Circle 375 on reader card

CCS Announces Port Of TRAX/COBOL Debugger

Corporate Computer Systems Inc. announced the MPE XL implementation of its TRAX/COBOL source level debugger. Compatible with CCS' MPE V TRAX, the XL version of TRAX enables COBOL statements and recompiling, and TRAX lets you interact with the actual application at the source code level. You can stop program execution, print and change user identifiers and even single step through your program all without



a PowerHouse[®] schema and forget about Recompiling

Why waste hours, when you can do it in minutes

ORDER Q Modify TODAY
ONLY \$995 U.S.

M.B. FOSTER ASSOCIATES LIMITED
50 Water Street, P.O. Box 580
Chesterville, Ontario
Canada R0C 1P0
PHONE: (613) 448-2333
FAX: (613) 448-2388
TELEX: 053-3991 ANDREX-OTT

Call 1-800-ANSWERS

QModify is a trademark of Gier Colbin & Co Inc.
PowerHouse is a registered trademark of Cognis Inc.

CIRCLE 256 ON READER CARD

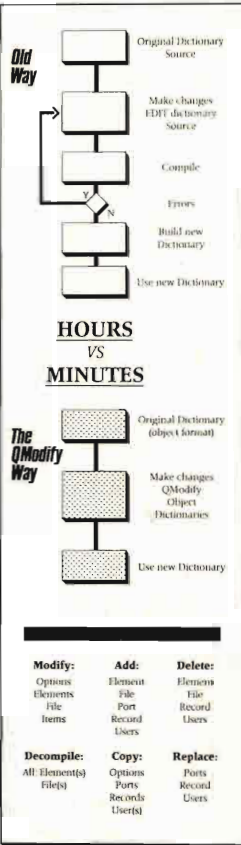

Until now, Powerhouse Training could be ~~EXPENSIVE~~. EXPENSES.

Besides tuition costs, there was:



Powerhouse Video Tape Training ... for the life of your company.

MODULES INCLUDE:
QUIZTRAIN, QUICKTRAIN, QTPTRAIN
QSCHTRAIN, and OMNITRAIN

In addition to standard course material, there are also efficiency tips and other unpublished tricks. Course materials include: video tape, workbook, and sample database.

For more information, please call:

(617) 556 - 8488
BONAFIDE EDUCATION
SUITE 307
184 B BROADWAY
SAUGAS, MA 01906-1029

CIRCLE 261 ON READER CARD

recompiling or relinking. With TRAX, bugs are simpler to find and existing applications are easier to understand and maintain. Programs become self-documenting because you can trace the logic flow through the real application operating on real data.

TRAX offers the user a multiwindow interface. The RT display is divided into two primary windows and several optional secondary windows. The initial interface view contains a command input window and a source code display window. Additional overlapping windows can be requested when you require more information. Windows all remain active even when partially obscured. You can restack windows to bring the information you want to the front of the display.

Contact Corporate Computer Systems Inc., 33 W. Main St., Holmdel, NJ 07733; (201) 946-3800.

Circle 376 on reader card

ProfitKey 532 Designed For UNIX Systems

ProfitKey International Inc. announced a packaged software product line, ProfitKey 532, for manufacturers who make-to-order, make-to-stock or do a combination of both. The new product is designed for UNIX System based computers with 32-bit architecture.

Key features of ProfitKey 532 include: 30-character part number; supports contract numbers, including government contract numbers; ProfitKey's unique Common Sense Scheduler featuring "Latest-Possible-Start-Date" scheduling; streamlined order-entry process; improved support for blanket orders and shipments to multiple locations; added support for multilevel tax structures; and enhanced inquiry capabilities.

Contact ProfitKey International Inc., 382 Main St., Salem, NH 03079; (603) 898-9800.

Circle 380 on reader card

Extended Memory Now Available For ZIM

Zanthe Information Inc. lets you configure for performance rather than space with the new extended memory version of ZIM.

The new DOS Extended version of ZIM, makes up to 16 MB of additional memory accessible to developers. Running in protected mode on 80286 and 80386 machines, ZIM Extended breaks the 640K barrier imposed by

DOS. This makes more than 500K available for other uses, including editors, network shells and TSRs.

Extended ZIM runs on DOS 3.0 or later and requires 1 MB of extended memory.

Contact Zanthe Information Inc., 1200- 38 Antares Dr., Ottawa, Ontario Canada K2E 7V2; (613) 727-1397.

Circle 388 on reader card

Holland House Enhances UNISPOOL/UX

Holland House has announced enhancements to UNISPOOL/UX allowing spooling to and from HP 9000 Series 300 and 800. Spoolfiles can be sent from an HP 3000 (MPE V and XL) to an HP 9000 and from the HP 9000 Series 300 to HP 9000 Series 800 and vice versa. Spool9000 runs in conjunction with UNISPOOL and must be purchased as an add on module to UNISPOOL.

Contact Holland House, P.O. Box 1749, Beeville, TX 78102; (512) 287-3417.

Circle 374 on reader card

Link Unveils Printer Protocol Converters

Link Electronics has introduced the LYNX 25X printer protocol converter for HP users. LYNX was designed for HP 3000 Classic and HP 3000/9000 Precision Architecture system, giving users access to a broad range of third-party printers, including band, dot matrix, daisywheel and laser printers. LYNX emulates the HP 256X printer family.

The printer protocol offers 60 resident fonts, standard and international character set support and delivers 8K of user-programmable macros so that multikey functions can be stored in memory and initiated by a single keystroke. Price \$2,195.

Contact Link Electronics Inc., 1360 Bordeaux Dr., Sunnyvale, CA 94089; (408) 734-4200.

Circle 373 on reader card

FOR YOUR INFORMATION

■ Cognos Inc. (Ottawa, Ontario) is shipping worldwide its PowerHouse Electronic Classroom, a new series of computer-based training (CBT) courses. The courses are designed to teach new PowerHouse application designers how to use the three main components of the 4GL: QUIZ, a report-generator; QUICK, a screen-menu- and forms-generator, and QTP, a special facility for data manipulation and batch processing. Course

packages require either an IBM PC-XT, PC-AT or compatible computer with 640 KB of memory, 3 MB of hard disc space and DOS version 2.11 or later. PowerHouse training for the HP 3000, VAX, DG MV and PC is included on the same diskettes.

■ Jobscope Corp. (Greenville, SC) has published a four-page brochure on the range of support services available to licensees of Jobscope factory management software. The Jobscope Support Program includes software updates and upgrades to new versions, access to the Jobscope Help Desk, and Jobscope Communicator newsletter.

■ Data Sheets now are available from Compact Software (Paterson, NJ) that provide detailed information on the computer-aided design tool that brings together an array of CAD tools all in one flexible package.

■ Soft-Switch Inc., (Wayne, PA) is offering "Electronic Mail: Technology, Applications and Infrastructure," a 62-page illustrated white paper providing comprehensive overview of Electronic Mail. The paper offers insight into the evolution of electronic mail technology and applications and trends that will impact the future of enterprise mail networks.

■ LPI Publishing Co., (Agoura, CA) publisher of the Directory of Digital Font Libraries, announced the prepublication compilation of its newest book, *The Directory of Computer Industry Consultants*. The intention of this directory is twofold: 1) to aid companies and organizations who have a need to hire a consultant but currently have no point of reference in selection; 2) to give consultants a method of promoting their services on a national level.

■ Neuron Data, vendor of standard expert system technology for commercial and industrial integration, has announced the opening of offices in London and New York City. The offices will serve as marketing and technical support centers for the company's leading expert system shell, Nexpert Object.

■ Crosfield Electronics Inc. (Glen Rock, NJ) instituted its Customer Service Hotline. The hotline provides technical telephone support outside regular office hours for Crosfield's customers throughout North America. Trained engineers and applications specialists are on call every day from 5 p.m. (EST) to 8:30 a.m. (PST) and 24 hours on weekends. The Hotline number is (800) 346-5847. ■

Continued from page 53.

ing this value is the analyst's responsibility. The other method is to edit the file with the user's favorite ASCII editor. This provides risk of extra problems, but the cautious individual may wish to pursue this course. The analyst, who designs the Application protocol, establishes the MPE file name and state specifics.

Implementation Concerns

Most applications are easily controlled through a comprehensive set of states. The wording of the message corresponding to each state *must* fully communicate that state's condition to each individual user. In situations where some individuals (new users) desire detailed descriptions while other individuals (operators) desire short efficient information, two message files may be of value. Another example would be where two languages are needed — for example, a bilingual staff of users. By simply creating two or more message files, the designer has the option of setting up UDC commands and user logons for multi-language environments, so the system could accommodate concurrent message delivery for French, German, Spanish, Swedish and English. This could make some users very happy.

Multiple State File Design

Applications run best with only one state file. I have implemented two extra files that provide maximum flexibility for our installation. The main state file "MASTER" has the true state of the production application. The first extra state file enables the user to collect test data. State file "TESTATE" has the state of "0" when no testing is to be done or one of the corresponding test data collection states when test data is to be extracted.

The second extra state file reminds users of incomplete (interrupted) processing. Our history indicated a need for a "gentle reminder" if the user had left a complex set of processes incomplete. This file is set to state "0" when all operations are complete. It has the state of the last

```

Program I.

number      message body
-----
100 +-----+
100 | The ALPHA database was just initialized!!! |
100 +-----+
120 +-----+
120 | The ALPHA system was backed up and is UP ! |
120 | [For help, call Lucy V.P. (analyst)]       |
120 +-----+
150 +-----+
150 | The ALPHA database is ready for USER work! |
150 | [For help, call Charley B. or Linus V.P.] |
150 +-----+
1300 *****
1300 | The ALPHA system is now in the process of |
1300 | system reconfiguration. Do not use any  |
1300 | feature! Stay on line and a TELL will   |
1300 | be sent to all system users when ready. |
1300 | [For help, call Snoopy (operations)]     |
1300 *****
4500 +-----+
4500 | USER HOLD IN EFFECT. REMOVE USING THE PROPER COMMAND, OR |
4500 | IF YOU ARE NOT AUTHORIZED. SEE YOUR DEPARTMENT MANAGER.  |
4500 |                                     |
4500 |                                     HAVE A NICE DAY. |
4500 +-----+
4900 -----
4900 --- STAND BY THE SYSTEM CRASH HAS DEPLETED ALL RESOURCES ---
4900                                     PigPenn-----

```

complex operation that was started but not finished.

The greatest potential for problems occurs when the analyst setting up the various possible states doesn't consider all current states or forgets to plan for future growth. Should this occur, the designer must redesign the state values, their respective messages and all related batch JCL and session UDCs.

Another area of potential problems resides in the training of the user/ operator/ manager community. Considerable confusion would be eliminated if the design is established with the cooperation of knowledgeable users and managers. The design should be taught to all parties who will interface with the message side of the application. The old logic flow charts serve us well, both in the design and training phases. Murphy's Law is always in effect, so it's possible for the Control file to become corrupt. When this happens, the analyst must be prepared to coordinate the repair with his user community. The last "good" state must be re-established. A determination of recovery steps must be made and

the work done to recover the application. Finally, the new logical control state must be installed with the SETSTATE program.

Control To Users

There's no substitution for good design. The state tools described have the functionality needed to give major control to application users. They are each necessary and flexible. The routines are implemented as three programs to enable maximum flexibility. This reduces memory requirements and reduces individual execution speed. Both Control and Message files have been designed as ASCII files for ease of design and maintenance. No measurable degradation in performance has been noticed.

The names of processes describe the type of logical function. Real names of our operating functions and application systems as well as our file names have been replaced with pseudo names for security reasons. This has no effect on the presentation of the design or the use of the programs. — Ted Lupien is Sr. Programmer Analyst for Du Pont, Newark, DE.

BUY • SELL • TRADE

COMPLETE HP SYSTEMS AVAILABLE

ALL PERIPHERALS

*All items in stock – immediate delivery
All warranted to qualify for
manufacturer's maintenance.*

ConAm Corporation

Canada / US 800-643-4954
California 213-829-2277
FAX 213-829-9607

RENT • LEASE

CIRCLE 208 ON READER CARD

**BUY, SELL
LEASE,
TRADE.**

Hewlett Packard



23950 COMMERCE PARK, BEACHWOOD, OHIO 44122
(216) 292-0635 Fax: 216-292-4838 Telex: 205129
CRC is a Trademark of Computer Remanufacturing Corporation

CIRCLE 206 ON READER CARD

HP 3000

**Buy — Sell — Trade
IN STOCK NOW 2392A & 7978B**

CALL
**713-460-2344
(Fax) 713-460-2351**

**Surety
Systems**

6617 Flintrock
Houston, TX 77040

CIRCLE 221 ON READER CARD

REPRINTS?

**If you would like
reprints of any article
or advertisement,
contact**

**Reprint Resources,
155 Commerce St.,
Fort Washington, PA
19034**

**(215) 643-9143,
FAX (215) 643-9164.**

BUY • SELL • LEASE • TRADE

Preowned HP

*DESKTOPS * PERIPHERALS
SYSTEMS * TEST EQUIPMENT*

800-662-9039

**ELECTRONIC
SERVICES, INC.**

*GUARANTEED EQUIPMENT
AT VERY
COMPETITIVE PRICES!!*

FAX 509-662-8271

5187 Malaga-Alcoa Hwy.
Malaga, Washington 98828

CIRCLE 211 ON READER CARD

WE WILL PAY

TOP PRICES

FOR YOUR

HP 9000

SERIES 200/300

*COMPUTERS, DISC DRIVES,
PRINTERS, PLOTTERS,
INTERFACES!*

**ALSO SERIES 80
& SERIES 100**

**TED DASHER & ASSOC.
4117 SECOND AVE. SOUTH
BIRMINGHAM, AL 35222**

**FAX: 205-591-1108
205-591-4747**

CIRCLE 223 ON READER CARD

HEWLETT-PACKARD

**BUY REPAIR
and and
SELL SERVICE**

ADVANT

Computer Exchange

HP Systems Specialists

US (800) 824-8418

CA (415) 623-1733

FAX (415) 623-1736

CIRCLE 231 ON READER CARD

WHOLESALE H-P

"There's simply no reason to pay more."

*Purchasers, Resellers and Component
Level Repairers of Hewlett Packard
Micro and Mini Computers
and Peripherals.*

9000 • 3000 • 1000 • MICRO

EQUIPMENT
RESOURCES,
INC.

For Sales Please Call:

Mark Leonard

(202) 338-2429

**2702 P Street, N.W.
Washington, DC 20007**

FAX: (202) 338-2462

CIRCLE 200 ON READER CARD

BUY • SELL • RENT • LEASE

HEWLETT-PACKARD

Computer Equipment

9000 • 3000 • 1000

AVAILABLE FOR IMMEDIATE DELIVERY

800-422-4872

FAX 713-855-1213

TSA

**TECHNICAL & SCIENTIFIC
APPLICATION, INC.**

**4654 Highway 6 N., Suite 101
Houston, TX 77084**

"The Awesome HP Source"

CIRCLE 225 ON READER CARD

WHEN THEY THINK HP

Dupont Duke University
General Motors Motorola
McDonnell Douglas GTE

OUR NAME
ALWAYS COMES UP.



813/573-0330

FAX 813/573-1577

"WE BUY, SELL AND RENT HP 1000/9000/3000
COMPUTERS, PERIPHERALS & TEST EQUIPMENT."
13160 56th Court • Suite 503 • Clearwater, FL 34620

CIRCLE 203 ON READER CARD

HP1000 & 3000



- BUY • SELL • LEASE • RENT
- Repair & Exchange
- \$3,000,000 Inventory
- 120 Day Warranty
- 20 Years Experience
- Hardware • Software • Service

Computer Solutions, Inc.

NJ 201/672-6000

TLX 130098 • FAX 201/672-8069

CIRCLE 207 ON READER CARD

The HyPoint Advantage . . . INVENTORY

"Specializing in Full
Line of
HP 3000 Products"

Buy ■ Sell ■ Trade ■ Lease

HyPoint Technology
4333 E. Royalton Road
Cleveland, OH 44147

1-800-231-5500

216-526-0323

CIRCLE 212 ON READER CARD

HP-9000

WE STOCK A LARGE VARIETY
OF SERIES 200/300 EQUIPMENT

CPU's	Monitors
9920/A/U	Video Boards
9816A/S	Interfaces
9817A/H	Disc Drives
9836B/C	Printers
310's B&W,	Plotters
COLOR	

Series 80 and Series 100

CALL US TODAY TO BUY AND/OR SELL

TED DASHER & ASSOCIATES

205-591-4747 FAX 205-591-1108

CIRCLE 224 ON READER CARD

HEWLETT PACKARD

BUY, SELL
RENT & REPAIR

**COMPUTERS,
PERIPHERALS
& OPTIONS**

SALES: 800-726-0726 SERVICE: 800-729-0729

FAX: 408-270-1183 TELEX: 9102500341

2298 QUIMBY ROAD
SAN JOSE, CALIFORNIA 95122-1356

CRISIS
COMPUTER CORPORATION

CIRCLE 209 ON READER CARD

Join a Winning Team!

Join the HP VAR Program through
ACE COMPUTER CENTER

HIGH DISCOUNTS
IMMEDIATE PRODUCT AVAILABILITY
RELIABLE SERVICE AND SUPPORT
ACCESS TO PRODUCT SUPPORT

AND
TECHNICAL MATERIAL

For more information Call...

SALES: (404) 952-5537 / FAX: (404) 933-4788



120 Interstate North Parkway / Atlanta, Georgia 30339

CIRCLE 196 ON READER CARD

BUY • SELL • TRADE • RENT

**Hewlett-Packard
Computer Equipment**

Complete product line
including Systems, Memory,
Discs, and Tapes.



HERSTAL

AUTOMATION LTD.
3171 West Twelve Mile Road
Berkley, Michigan, USA 48072
Telex 650-321-1560
FAX 313-548-2010
Phone 313-548-2001

CIRCLE 235 ON READER CARD

WE'LL SAVE YOU TIME AND
MONEY ON YOUR NEXT

HEWLETT PACKARD

PURCHASE!



MICROTEK SYSTEMS
INTERNATIONAL, INC.
8370 DOW CIRCLE
CLEVELAND, OH 44136

CLEVELAND, OH: (216) 234-8040
FAX (CLEVE): (216) 234-0784

CIRCLE 260 ON READER CARD

INFORMATION

Rates: 1 time: \$400
3 times: \$370
6 times: \$340
12 times: \$285

Size: 1/9 page — 2³/₁₆" x 2³/₄"

Typesetting and composition
available.

Camera ready mechanical
required.

For more information call
**Cynthia Leitzel at
(215) 957-1500.**

C.S.U.
INDUSTRIES,
INC.



The second source for
HEWLETT-PACKARD
HP 9000, 3000, 1000 equipment

- Complete Configurations
- Individual CPUs — Peripherals
- Memory Upgrades and Feature Enhancements

WE BUY:
Highest Prices Paid

WE SELL:

All Items Sold Are Guaranteed for HP Maintenance
* Trade-Ins Accepted * Short and Long Term Leases Available *
Over 900 satisfied Hewlett-Packard users
are our customer references.

CALL (516) 239-4310
Telecopy (516) 239-8374

135 Rockaway Turnpike • Lawrence, NY 11559

CIRCLE 202 ON READER CARD

HP-3000/HP-9000

Fidelity Systems, Inc.



ALSO:
OTC
DATA PRODUCTS
CUMULUS
IO NET

CALL

713-266-3009

CIRCLE 183 ON READER CARD

- IN STOCK SPECIALS ■
- 7937H & XP (QTY)
- 7980A ■ 2567B
- SERIES 70 w/8Mb
- 7958A ■ 2932A
- MICRO 3000XE w/4Mb
- 7978A/B ■ 7580A
- SERIES 58 w/4Mb
- 2392A ■ 2235A
- ZENTEC 8392 @\$295
- 35401A 1/4" Autochanger

CALL OCEONICS TODAY

800-525-0509

CIRCLE 216 ON READER CARD

9000, 3000, 1000
SYSTEMS
PERIPHERALS
COMPATIBLES

Buy • Sell • Trade
Maintenance



(206) 883-4107
(US) 800-882-0201

CIRCLE 204 ON READER CARD

WANTED

HP 3000/68 CPU
WITH OR
WITHOUT
PERIPHERALS.

(718) 318-3360

CIRCLE 265 ON READER CARD

Save up to 60%!

Top dollar when you sell!

We buy or sell any HP equipment,
including:

COMPUTER SYSTEMS • DISK DRIVES
SOFTWARE • ACCESSORIES
TERMINALS • MAG TAPES

All Equipment Guaranteed.

Specialists in hard-to-find equipment.
Immediate delivery of in-stock items.

CALL Bill Alexander at

312-916-1400

FAX 3129161361

COMPUTER MEDIA, INC.

1420 Brook Drive
Downers Grove, IL 60515

CIRCLE 205 ON READER CARD

BUY • SELL • RENT • LEASE

HEWLETT-PACKARD

Computer Equipment

SERIES 80, 100, 200, 300, 500, 9800

ALSO

Plotters, Printers, Disk Drives
CPUs, etc...

AVAILABLE FOR IMMEDIATE DELIVERY
800-422-4872

FAX 713-855-1213

TSA

TECHNICAL & SCIENTIFIC
APPLICATION, INC.

4654 Highway 6 N., Suite 305
Houston, TX 77084

"The Awesome HP Source"

CIRCLE 226 ON READER CARD

USED HEWLETT PACKARD

	LIST \$	A&O \$
LaserJet - Original	\$3200	\$ 795
LaserJet - Plus	\$4000	\$ 895
LaserJet - 500D	\$5000	\$1050
LaserJet - Series II	\$2950	\$1395
7475A 6-Pen Plotter	\$1895	\$ 950
7550A 8-Pen Plotter	\$3900	\$2200
Scan Jet w/Centronics	\$2000	\$ 650
ASF for Scan Jet	\$ 595	\$ 150

- 90 Day Warranty
- HP Service Guaranteed
- Technical Sales Staff



Free! Win an HP Model 110
LAP-TOP with MS-DOS
(List \$3000)

Alpha & Omega Computer Solutions

(201) 774-5322 FAX: (201) 774-1674

CIRCLE 253 ON READER CARD

NORCO COMPUTER SYSTEMS, INC.

*Hewlett-Packard Quality
at a NorCo Price*

1000 • 3000 • 9000 • 250

**BUY — SELL
TRADE — LEASE**

Processors, Peripherals
and Systems

925D Bassett Road
Cleveland, OH 44145-1108

FAX 2168925507

216-892-1920 1-800-892-1920
(Outside Ohio)

CIRCLE 215 ON READER CARD

**Sr. Programmer Analysts
\$35 to 50K**

Our established working relationship with the Hewlett Packard Corporation and several major software vendors supporting the HP platform continues to generate new opportunities for DP professionals across the nation. Participate in one of these state-of-the-art projects, and expand your 2+ years experience in one or more of the following disciplines:

POWERHOUSE SPEEDWARE MM/3000 PM/3000	TRANSACT OMNIDEX CUSTOMIZER HP-UX	PROTOS COBOL FORTRAN MANMAN
---	--	--------------------------------------

Benefit from one of the finest compensation programs in the industry. Relocation assistance is also available. For more information, call CAROL



ENGLISH or SARAH TERRY at 1 (800) 444-4917. To apply, send your resume to: WESSON, TAYLOR, WELLS, Dept. P-10, P.O. Box 1587, Camden, SC 29020. EOE.

CIRCLE 229 ON READER CARD

HP CAREERS - NATIONWIDE

YOU BE THE JUDGE . . .

Has your career come to a standstill? Do you need more challenge or responsibility in your job? If so, list with the recruiter who represents the largest number of HP clients nationwide!! Due to my extensive activity and contacts in the HP industry, I have numerous opportunities to offer a qualified HP professional. Call today to see how you might improve your career path.



CALL
Diane Amos, C.P.C.

**Amos &
Associates**

633-B Chapel Hill Road
Burlington, NC 27215
(919) 222-0231
FAX: (919) 222-1214

CIRCLE 217 ON READER CARD

**HP CONSULTANTS
& RECRUITERS!**

Advertise your services in
**HP PROFESSIONAL'S
Consultants' Directory.**

- **Reach 30,000+ HP Users** — Commercial & technical, corporate executives to technical staff.
- **High Visibility** — One page of listings dedicated to consultants & recruiters.
- **Reader Service Numbers** — Fast, accurate leads with full demographics.
- **Reasonable Rates**
Call Cynthia Leitzel
(215) 957-1500
to reserve space
RESERVE SPACE NOW!

SOFTWARE

Series 200/300 BASIC Specialists

Fast and Functional

- **SYS.100** VT100/220 terminal emulation/file transfer
- **SYS.4010** Tektronix 4010 emulation
- **SYS.XM** XMODEM text/binary file transfer, error-corrected
- **FILEX** HP to HP file transfer; any type (PROG, BIN, etc.)
- **SCR2** Screen utility — many features
- **SERBUF** Serial buffer — no hassles

SYSTEM WORKS

4318 Centennial Trail • Duluth, GA 30136 • (404) 446-6098

CIRCLE 222 ON READER CARD

Oswego Software, Inc.

IBM PC to HEWLETT PACKARD FILE COPY

- Up to 10 times **FASTER!**
- **USER INTERFACE!**
- **MORE POWERFUL!**

Read & write HP floppies in your PC

\$495

Call us. **OSWEGO SOFTWARE**
P.O. Box 310
Oswego, IL 60543
U.S.A.
312-554-3567
FAX 312-554-3573

CIRCLE 218 ON READER CARD

**IBM ↔ HP
File Interchange**

PCLIF is a software utility which permits the transfer of files between IBM PC's, PS/2's and HP technical (LIF) computers thru the exchange of floppy disks. Using the PC for 5.25" or the PS/2 for 3.5" transfers does not require additional hardware. An internal and an external 3.5" disk drive is available to allow the PC family to perform 3.5" disk transfers.

Innovative Software Systems
14252 Culver Dr., Suite A-444
Irvine, CA 92714 (714) 249-2056

CIRCLE 213 ON READER CARD

Why this publication and more than 1,300 others let us go over their books once a year.

once a year.

Some publications...we're sorry to say, keep their readers undercover. They steadfastly refuse to let BPA (Business Publications Audit of Circulation, Inc.) or any other independent, not-for-profit organization audit their circulation records.

On the other hand, over 1,300 publications (like this one) belong to BPA. Once a year, BPA auditors examine and verify the accuracy of our circulation records.

The audit makes sure you are who we say you are. The information helps advertisers to determine if they are saying the right thing to the right people in the right place.

It also helps somebody else important...you. Because the more a publication and its advertisers know about you, the better they can provide you with articles and advertisements that meet your information needs.

BPA. For readers it stands for meaningful information. For advertisers it stands for meaningful readers. Business Publications Audit of Circulation, Inc. 360 Park Ave. So., New York, NY 10010.



ADVERTISERS INDEX

Reader Service Number	Page
101 Access Technology	28-29
161 APPIC USA, Inc.	41
104 Bering Industries	73
169 Bering Industries	75
261 Bonafide Education	89
175 Bradford Business Systems	45
180 Bradmark Computer Systems, Inc.	I.B. Cover
107 Business Systems International	4
108 Cardinal Data Corp.	39
109 Cognos Corporation	1
164 Collier-Jackson, Inc.	23
167 CompuTech Systems Corp.	57
158 Computer Solutions	72
241 Corporate Computer Systems	17
152 The Computer Museum	84
182 Cort Directions	84
111 Data Based Systems Inc.	21
178 DTACK Systems	5
259 Duplication Technology	52
112 Dynamic Information Systems Corp.	37
113 EMC Corporation	9
244 Equinox Systems, Inc.	49
245 Equinox Systems, Inc.	51
246 Equinox Systems, Inc.	53
115 Herstal Automation Ltd.	69
190 Hewlett Packard (Network Systems Sector)	14-15
143 Hewlett Packard (Remarketing Division)	81
116 Hi-Comp International	63
117 IEM, Inc.	2

Reader Service Number	Page
118 IMACS Systems Corp.	11
119 Indigo Software	74
172 Infocentre Corp.	67
188 Innovative Information Systems, Inc.	4
120 Innovative Software Solutions	88
170 Intelligent Interfaces, Inc.	45
123 IOTECH	88
184 James Associates	65
173 Kelly Computer Systems	55
126 Martinsound Technologies	13
256 M.B. Foster & Associates	89
232 MCG Corporation	71
197 Mitchell Humphrey & Co.	87
149 National Instruments	50
129 NSD, Inc.	79
131 Peripherals	46
176 Persoft	I. F. Cover
134 Quality Consultants Inc.	83
156 Running Mate	77
136 SOTAS International	35
179 STR Software Company	85
147 TAPEDOC	85
155 Telamon	58-59
138 Tynmlabs Corp.	61
165 Tynmlabs Corp.	27
238 Tynmlabs Corp.	6-7
139 Unified Software Systems	26
141 Unison Software	19
186 VitalSoft	33
142 Walker Richer & Quinn, Inc.	B. Cover
240 Walker Richer & Quinn, Inc.	47

[CALENDAR]

[OCTOBER]

19: INRUG bimonthly meeting at HP office in Carmel, IN. For information call Dave Largent (317) 284-4461.

30-11/1: The Relational Institute is sponsoring a course for PC users, SQL And Relational Data "base"ics. Three-day seminar for managers, DP/MIS personnel. Call Relational Institute, (408) 268-8821.

[NOVEMBER]

8-10: GNYUG is holding its first annual HP3000 International Conference at the Penta Hotel, New York City. Call John Evans (716) 343-9775.

13-17: Abacus Programming Corp. is offering a Hands-On Course in Expert Systems and Knowledge Engineering. Course fee \$1,495. Contact Dr. Ronald Citrenbaum, (818) 795-8000.

15: NECRUG is holding its Winter Quarterly Meeting at the Wilmington Hilton Hotel, 1

95 and Naamans Rd, Claymont, DE. Topic: Automated Data Collection. Contact Richard Weller (215) 750-1438 or John Werner (302) 239-2220.

27-29: German HUG fall conference in Cologne, W. Germany. For information, call Dieter Grey 49/711/246321 or fax: 49/711/232563.

[DECEMBER]

11-13: The Fifth Annual Access Technology 20/20 Users' Group at the Hynes Convention Center in Boston, MA. Call Karen Smith, Rosemary Walsh or Joanne Knowlton (508) 655-9191.

[JANUARY]

23-25: The 7th Annual UniForum (International Conference Of UNIX Operating Systems Users) is being held at the Washington DC Convention Center. For more information call (800) 323-5155, in Illinois (312) 299-3131.

ADVERTISING SALES OFFICE

Leslie Ringe, Associate Publisher
(617) 861-1994

CANADA

(215) 957-1500

Helen B. Marbach, Regional Sales Manager
101 Witmer Road
Horsham, PA 19044
FAX (215) 957-1050

MID-ATLANTIC/SOUTH ATLANTIC

(215) 957-1500

Cynthia Leitzel, Regional Sales Manager
Connie Mahon, Account Executive
101 Witmer Road
Horsham, PA 19044
FAX (215) 957-1050

MIDWEST & SOUTH

(215) 957-1500

Peter Senft, Regional Sales Manager
Cynthia Leitzel, Senior Account Executive
Connie Mahon, Account Executive
101 Witmer Road
Horsham, PA 19044
FAX (215) 957-1050

NEW ENGLAND/INTERNATIONAL

(617) 861-1994

Leslie Ringe, Regional Sales Manager
Alonna Doucette, Senior Account Executive
Kristi Wesslen, Account Executive
238 Bedford St., Ste. 3
Lexington, MA 02173
FAX (617) 861-7707

NORTHERN CALIFORNIA & NORTHWEST

(415) 873-3368

A.G. Germano, Northwest Regional Manager
Judy Courtney, Account Executive
903 Sneath Ln., Ste. 220
San Bruno, CA 94066
FAX (415) 873-6608

SOUTHERN CALIFORNIA/SOUTHWEST/

COLORADO

(818) 577-5970

David Beardslee, Southwest Regional Manager
Karin Altonaga, District Sales Manager
Mary Marbach, Account Executive
1010 E. Union St., Ste. 101
Pasadena, CA 91106
FAX (818) 577-0073

(215) 957-1500

Phyllis Chandler, Advertising Services Manager
Mary Browarek, Classified Ad Manager
Cathy Dodies, List Rental Manager
Jane L. Hope, List Rental Sales

DB GENERAL

★ **Automatic capacity management**

DBGGENERAL monitors and changes dataset capacities automatically based on your configuration. Never worry about full datasets and changing capacities again.

★ **Dynamic detail set reorganization**

You can now stop and restart DBGGENERAL's detail set reorganization, and it will pick up where it left off. No more need to reserve several hours of exclusive access -- instead, run it for short periods whenever time is available.

★ **Global expert diagnostic**

Not only is this new diagnostic much faster and easier to use than anything we've ever offered, it also gives expert recommendations for solving the problems it detects - all it needs is the database name.

★ **Dynamic broken chain repair**

Broken chains are repaired in place with no path rebuild or unload/reload. There is no quicker method for fixing these and other critical problems.

★ **Single-pass structural changes**

From minor adjustments to major redesign, DBGGENERAL offers the most flexibility in database restructuring. Queue up changes or prepare a new schema, and even apply changes to multiple bases.

★ **Fast compressed tape backup**

DBGGENERAL's STORBASE module can reduce backup time from 35 - 50% and tape usage by 50% over conventional methods while retaining compatibility with transaction logging recovery.

★ **Optimum master capacity sampler**

DBGGENERAL includes a quick, simple, shared-access method for determining the optimal capacities for the best performance of your master datasets.

★ **Test database generation**

Stop testing programs and training users on production databases. DBGGENERAL can create small test databases with live data while keeping all relationships intact.

... and of course, 24-hour-a-day, 7-day-a-week technical support worldwide!

Houston	4265 San Felipe Houston, TX 77027 (713) 621-2808 Fax (713) 621-1639	Australia	(02) 484 3979	Germany	089/6088-3077
Buffalo	(716) 825-4021	Australia	(03) 874 3633	Germany	49 06722.6046
Cincinnati	(513) 891-7867	Belgium	(056) 41.83.99	Holland	(31) 2503-89700
Los Angeles	(213) 432-7713	Belgium	03.237.79.06	Israel	972-03-348938
		Canada	(613) 448-2333	Mexico	(525) 254-3274
		Denmark	(4) 2.63.22.33	Scandinavia	46 0910-364 80
		France	(1) 45.88.88.30	UK	(0223) 460881

BRADMARK
Computer Systems Inc.
CIRCLE 160 ON READER CARD



Reflection[®] runs through more PC-to-HP networks

Choose the PC network that best fills your company's needs — *then* choose **Reflection** for flawless emulation of Hewlett-Packard, DEC, and Tektronix terminals.

When you install Reflection, your PC becomes a dynamic workstation with features far beyond terminal emulation. Features including multitasking, dependable file transfer to HP, HP-UX and VAX/VMS hosts, a programmable command language, complete keyboard remapping, and a sophisticated PC file backup and restore function.

Reflection 1 PLUS (\$349) emulates HP 700/92, 700/94 and VT102 terminals.

Reflection 1 PLUS for the Macintosh (\$299) provides HP 2392A emulation.

Reflection 3 PLUS for the Macintosh (\$399) emulates HP 2393A graphics and HP 2392A terminals.

Reflection 7 PLUS (\$449) emulates HP 2627A color graphics and Tektronix 4014.

Reflection reaches even more networks and hosts with Reflection Complements, including:

TelnetManager (\$99), adds Telnet protocol to Reflection on your PC for high-level terminal emulation to hosts on TCP/IP networks;

3270 FileExchange (\$99), for transferring files to IBM mainframes;

MNP SoftModem (\$79), a software solution for error-free communications.

Call toll-free to order Reflection from Walker Richer & Quinn, the connectivity specialists.

REFLECTION[®]
SERIES
SOFTWARE
800-872-2829

Walker Richer & Quinn, Inc. 

2825 Eastlake Avenue E., Seattle, WA 98102
206-324-0350 FAX 206-322-8151

CIRCLE 142 ON READER CARD

Shipping and applicable taxes are added to quoted prices. Reflection is a registered trademark of Walker Richer & Quinn, Inc. Other brand and product names are trademarks of their respective holder.